

DMS-3 GPS COORDINATES  
34.74770° N  
78.99745° W

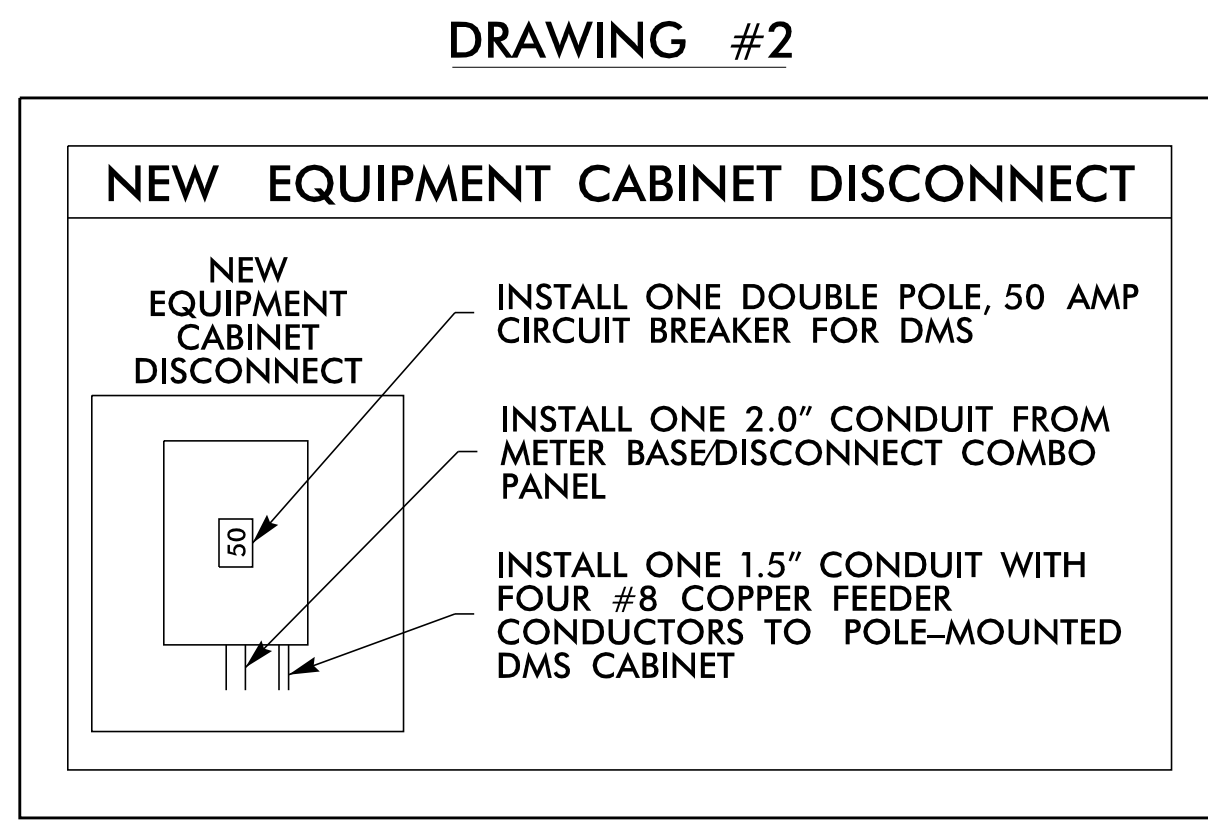

- NOTES:**
1. POWER COMPANY CONTACT - DUKE ENERGY - ERIC CHAVIS (910) 506-6531.
  2. REFER TO SHEETS 3B-5 THROUGH 3B-7 FOR GUARDRAIL INFORMATION.
  3. MAINTAIN A MINIMUM OF 6 FEET FROM THE EDGE OF PAVEMENT WHEN TRENCHING PARALLEL TO THE ROADWAY.
  4. CONTACT DIVISION 6 TRAFFIC ENGINEER FRANK D. WEST, JR. AT (910) 364-0606 TO CONFIRM THE LOCATION OF THE CCTV/DMS.
  5. DO NOT INSTALL CONDUIT OR JUNCTION BOXES UNTIL THE PROPOSED LOCATION OF THE CCTV CAMERA OR DMS HAVE BEEN CONFIRMED BY THE DIVISION TRAFFIC ENGINEER.
  6. MOUNT THE CCTV CAMERA 45 FEET ABOVE GRADE.
  7. MOUNT THE CCTV CAMERA 5 FEET BELOW THE TOP OF THE POLE.
  8. REMOVE DMS STRUCTURE FOUNDATIONS (2), CABINET, AND CABINET FOUNDATION

4/6/2022  
R:\ITS\Files\gmp\on\_Sheets\I-5987A\ITS\_psh\_09\_DMS ot MM 27\_SB.dgn  
4:03:13 PM

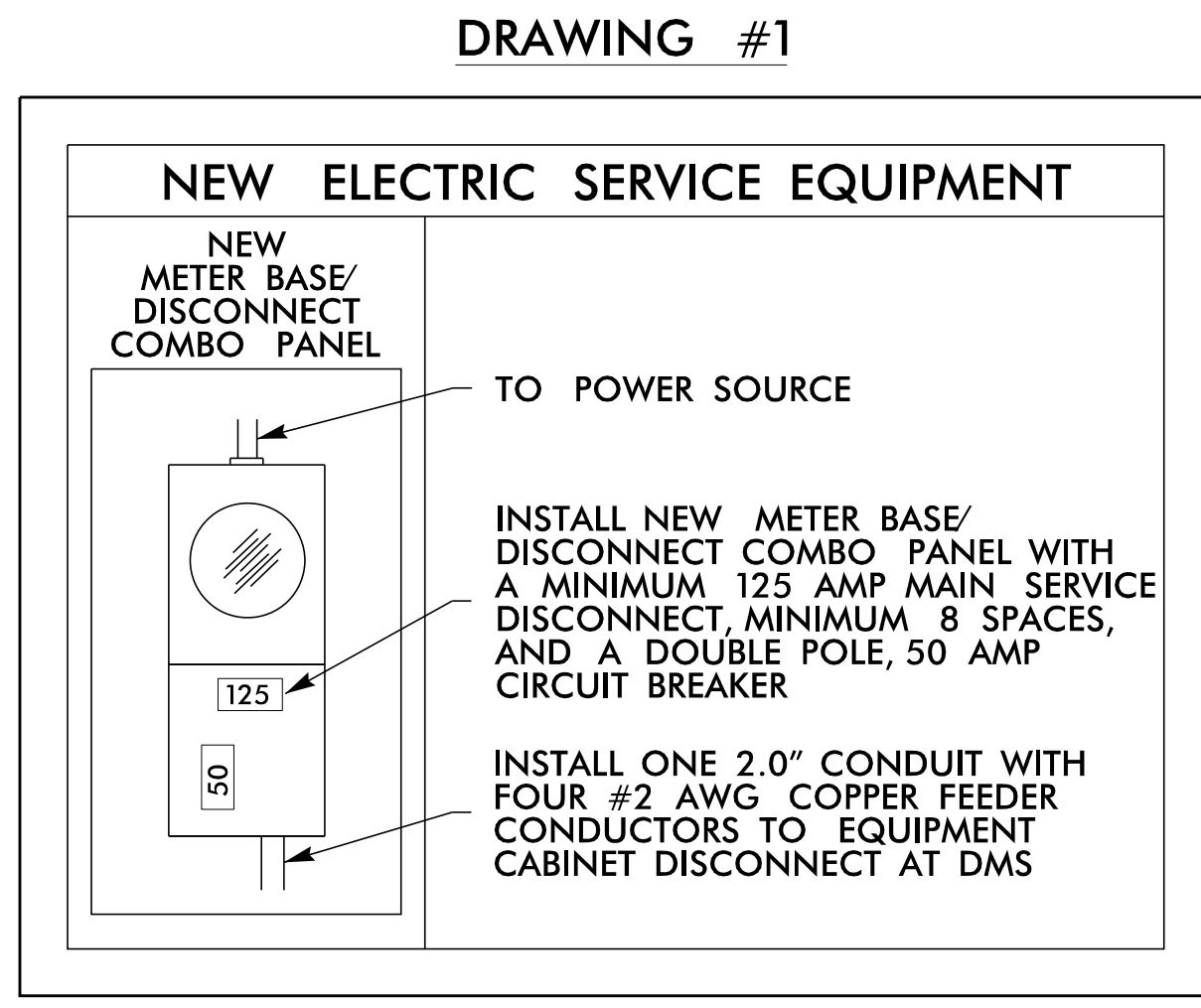
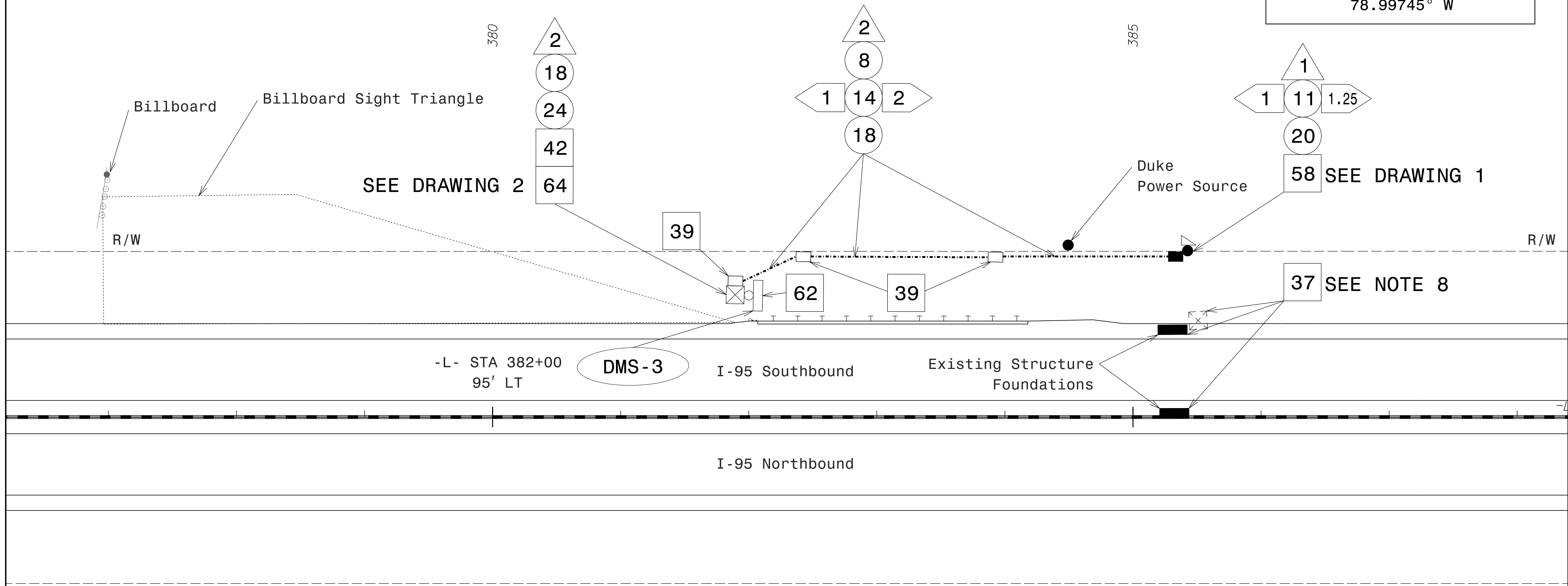
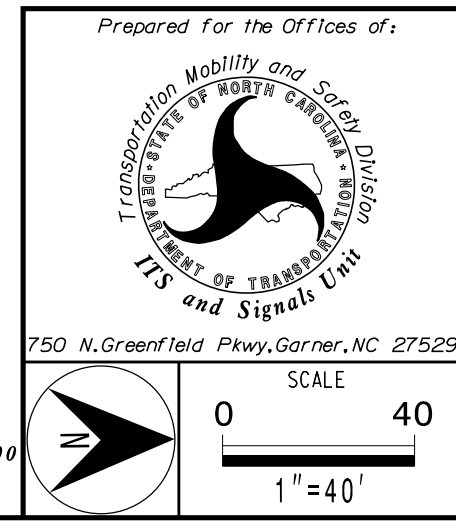

I-95  
DMS-3  
(Mile-Marker 27)

Division 6 Robeson County Lumberton

PLAN DATE: April 2022 REVIEWED BY: S.G. Haynie

PREPARED BY: O. Drobny REVIEWED BY: J. S. Cole

REVISIONS	INIT.	DATE

DocuSigned by:  
Steven G. Haynie 4/8/2022

CADD Filename: \_\_\_\_\_

DOCUMENT NOT CONSIDERED FINAL  
UNLESS ALL SIGNATURES COMPLETED

