

A2-15 QUANTITY = 8359 SQ. FT.

TEMPORARY SHORING
FROM -L- STA. 347+00, -9.0'
TO -L- STA. 362+00, -9.0'

(SEE SHEET TMP-2TS6 FOR
TEMPORARY SHORING NOTES)

MATCHLINE -L- STA 340+00.00 SEE SHEET TMP-127
END I-5987A SECTION 1 - BEGIN I-5987A SECTION 2

MATCHLINE -L- STA 353+00.00 SEE SHEET TMP-184

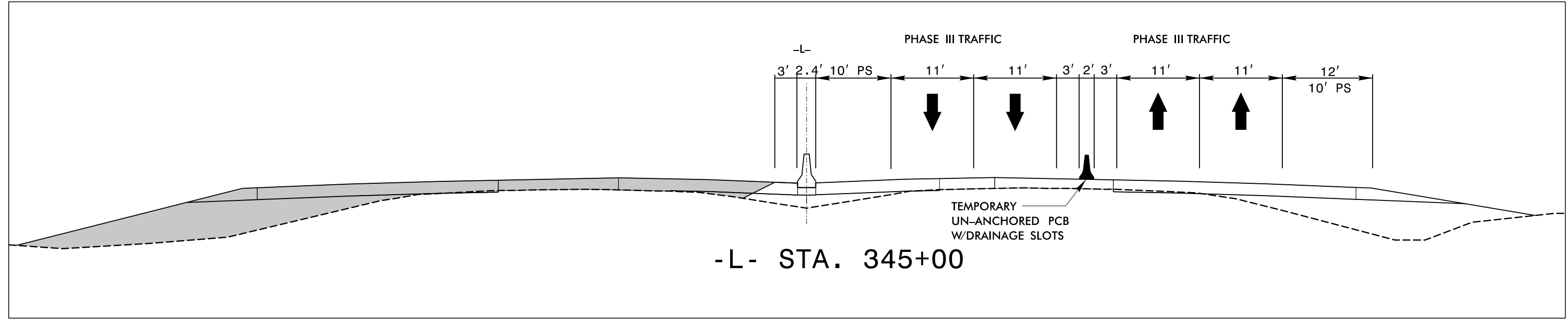
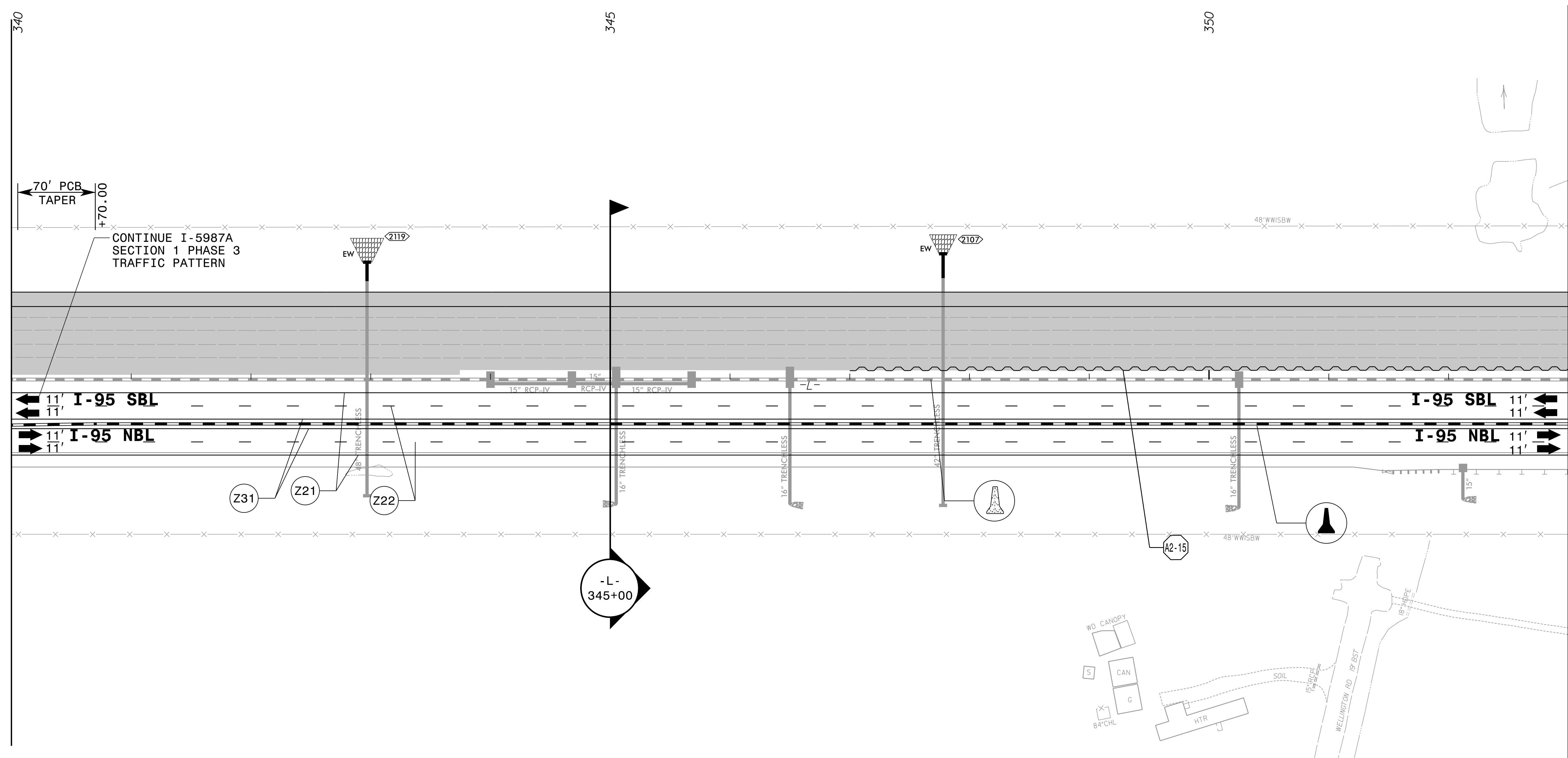

APPROVED: _____
DATE: 04/12/2022

5/18/2022

**DOCUMENT NOT CONSIDERED FINAL
UNLESS ALL SIGNATURES COMPLETED**

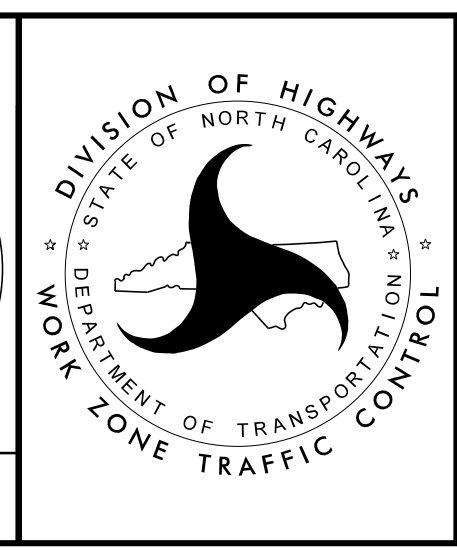

TEMPORARY TRAFFIC CONTROL
PHASE III DETAIL

4/12/2022
X:\Raleigh\20-0629.001 - I-5987A TCP Sec II\05-CAD\I-5987A\TrafficControl\TCP\PSHV\Phase 3\I-5987A_TMP_pshi83.dgn
JAdorno