

**A2-5** QUANTITY = 499 SQ. FT.  
 TEMPORARY SHORING  
 FROM -L- STA. 385+35, 34.0'  
 TO -L- STA. 385+96, 34.0'  
 (SEE SHEET TMP-2TS5 FOR  
 TEMPORARY SHORING NOTES)

**A2-6** QUANTITY = 499 SQ. FT.  
 TEMPORARY SHORING  
 FROM -L- STA. 385+35, 39.0'  
 TO -L- STA. 385+96, 39.0'  
 (SEE SHEET TMP-2TS5 FOR  
 TEMPORARY SHORING NOTES)

**A2-19** QUANTITY = 463 SQ. FT.  
 TEMPORARY SHORING  
 FROM -L- STA. 385+34, -4.0'  
 TO -L- STA. 385+95, -4.0'  
 (SEE SHEET TMP-2TS7 FOR  
 TEMPORARY SHORING NOTES)

**A2-20** QUANTITY = 463 SQ. FT.  
 TEMPORARY SHORING  
 FROM -L- STA. 385+34, -9.0'  
 TO -L- STA. 385+95, -9.0'  
 (SEE SHEET TMP-2TS7 FOR  
 TEMPORARY SHORING NOTES)

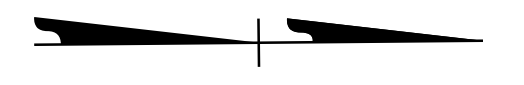

MATCHLINE -L- STA 380+00.00 SEE SHEET TMP-173

MATCHLINE -L- STA 393+00.00 SEE SHEET TMP-175

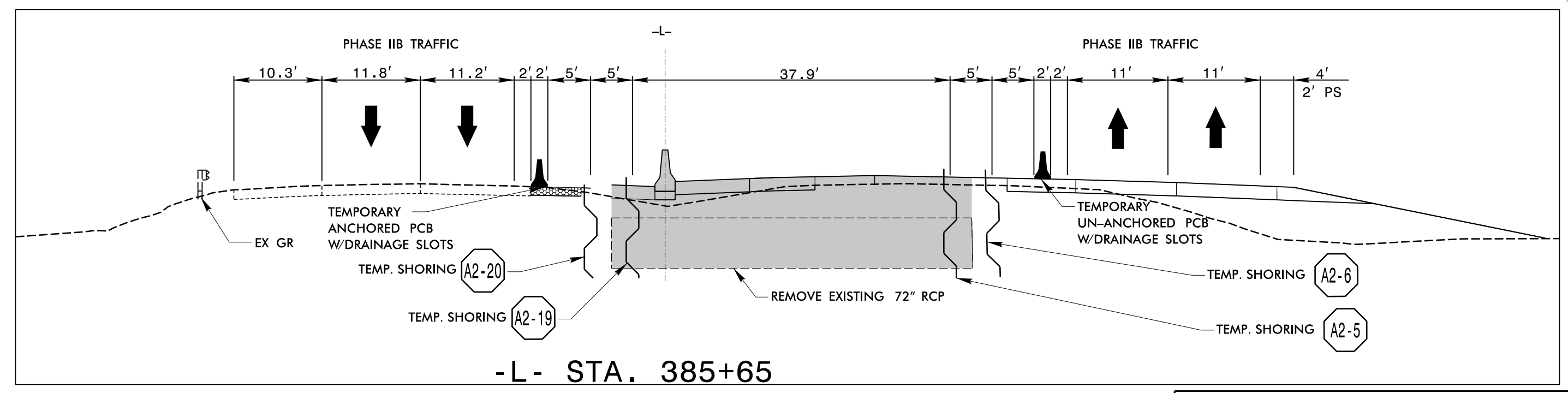
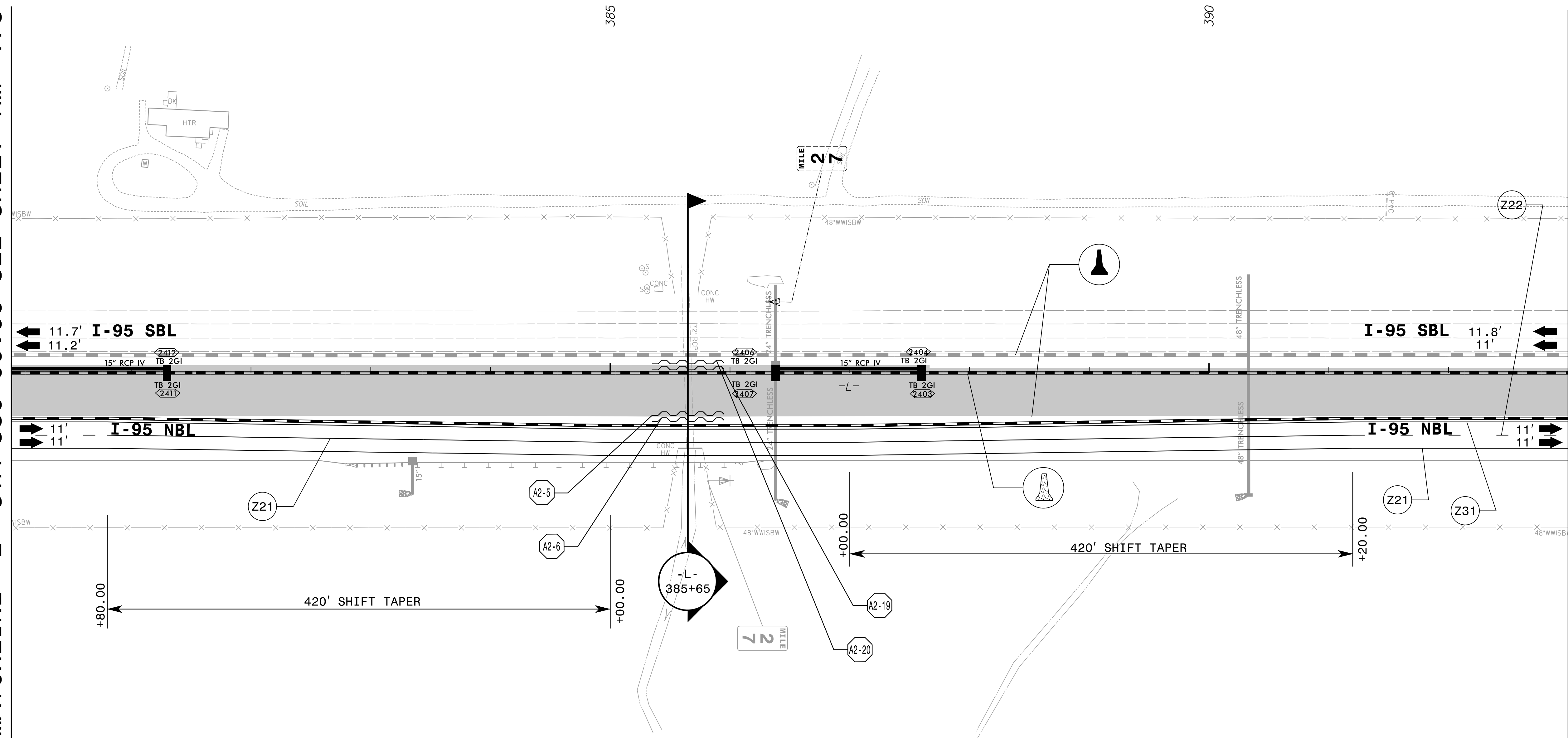

APPROVED: \_\_\_\_\_  
 DATE: 04/12/2022

5/18/2022

**DOCUMENT NOT CONSIDERED FINAL  
 UNLESS ALL SIGNATURES COMPLETED**

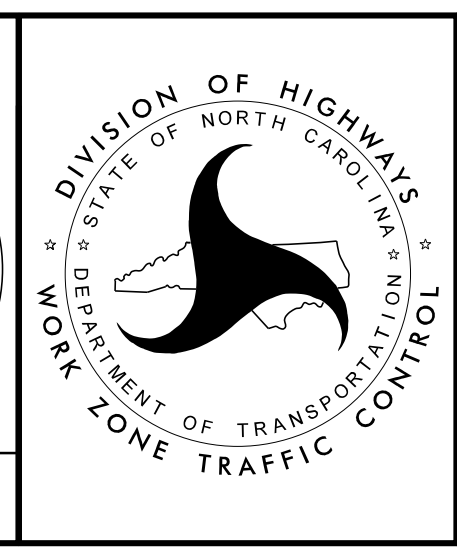

**TEMPORARY TRAFFIC CONTROL  
 PHASE IIB DETAIL**

4/15/2022 X:\Raleigh\20-0629.001 - I-5987A TCP Sec IN\05-CAD\I-5987A\TrafficControl\TCP\PSHV\Phase 2B\I-5987A-TMP\_psh174.dgn JAdorno