

5/14/22
5/16/2022
R:\P\03\15987A_RDY_TYP_SECA1.dgn

PAVEMENT SCHEDULE	
A1	13.5" PCCP W/ DOWEL
C1	3" S9.5D
C3	3" S9.5C
C6	3" S9.5B
C7	1.5" S9.5B
D1	4" I19.0C
E1	12" B25.0C
E2	4" B25.0C
E4	5.5" B25.0C
K2	12" CLASS IV SUBGRADE STABILIZATION
N1	NONWOVEN GEOTEXTILE INTERLAYER
N2	GEOTEXTILE FOR SOIL STABILIZATION
R4	SHOULDER BERM GUTTER
R6	SINGLE FACED CONCRETE BARRIER
R7	TYPE T BARRIER
R8	SINGLE SLOPE BARRIER
R9	4" CONCRETE COVER
T	EARTH MATERIAL
U	EXISTING PAVEMENT
V1	2" MILLING
W1	SEE WEDGING DETAIL 1
W2	SEE WEDGING DETAIL 2
Y	MILLED RUMBLE STRIPS

NOTE: PAVEMENT EDGE SLOPES ARE 1:1 UNLESS SHOWN OTHERWISE.

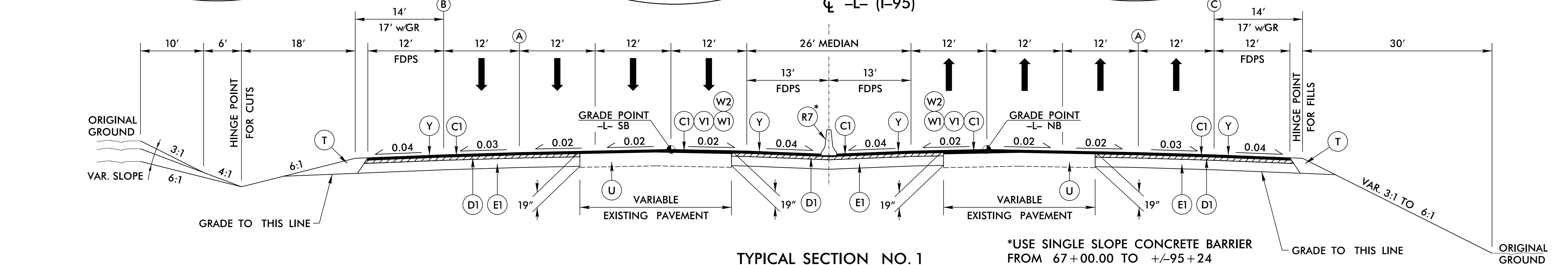
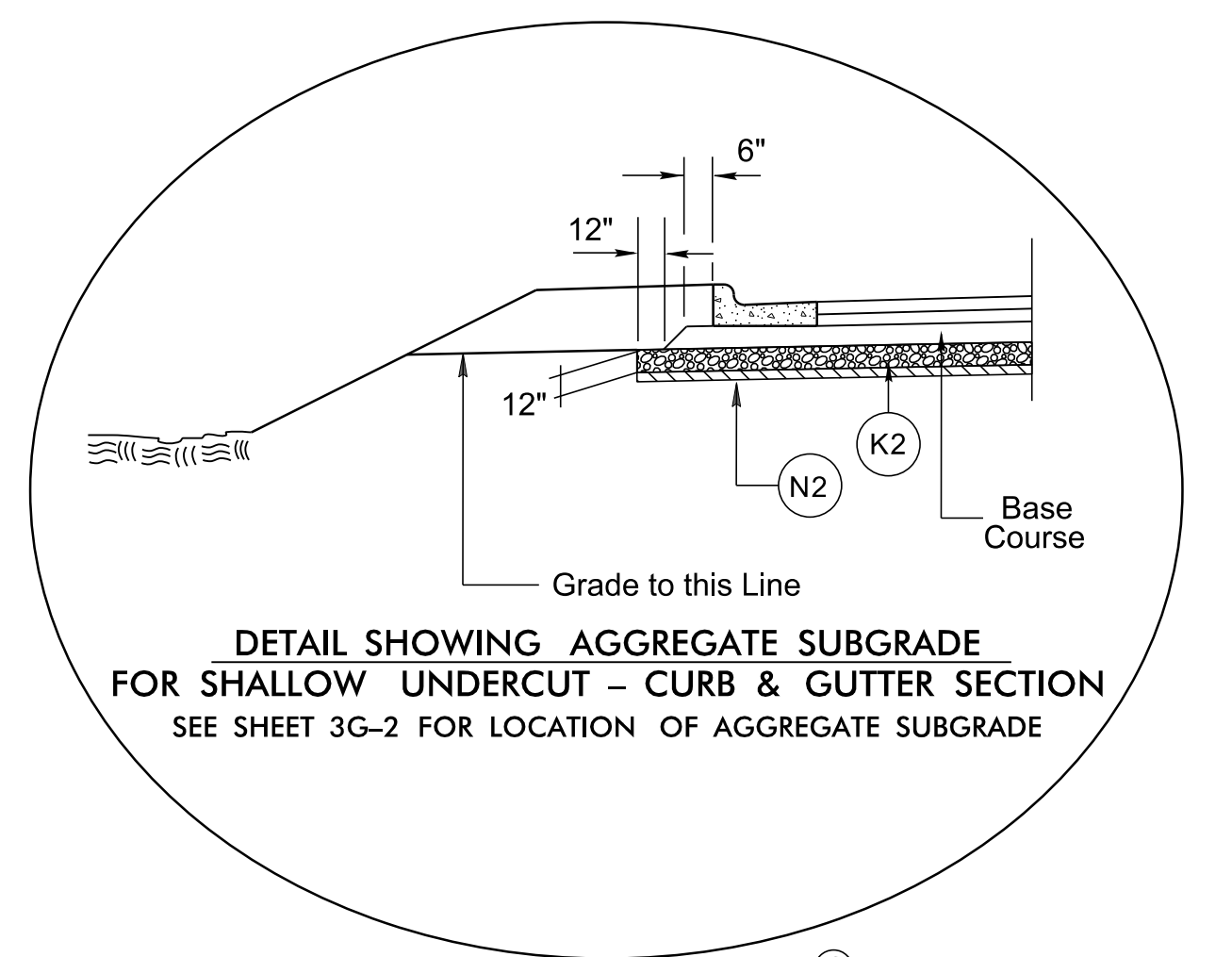
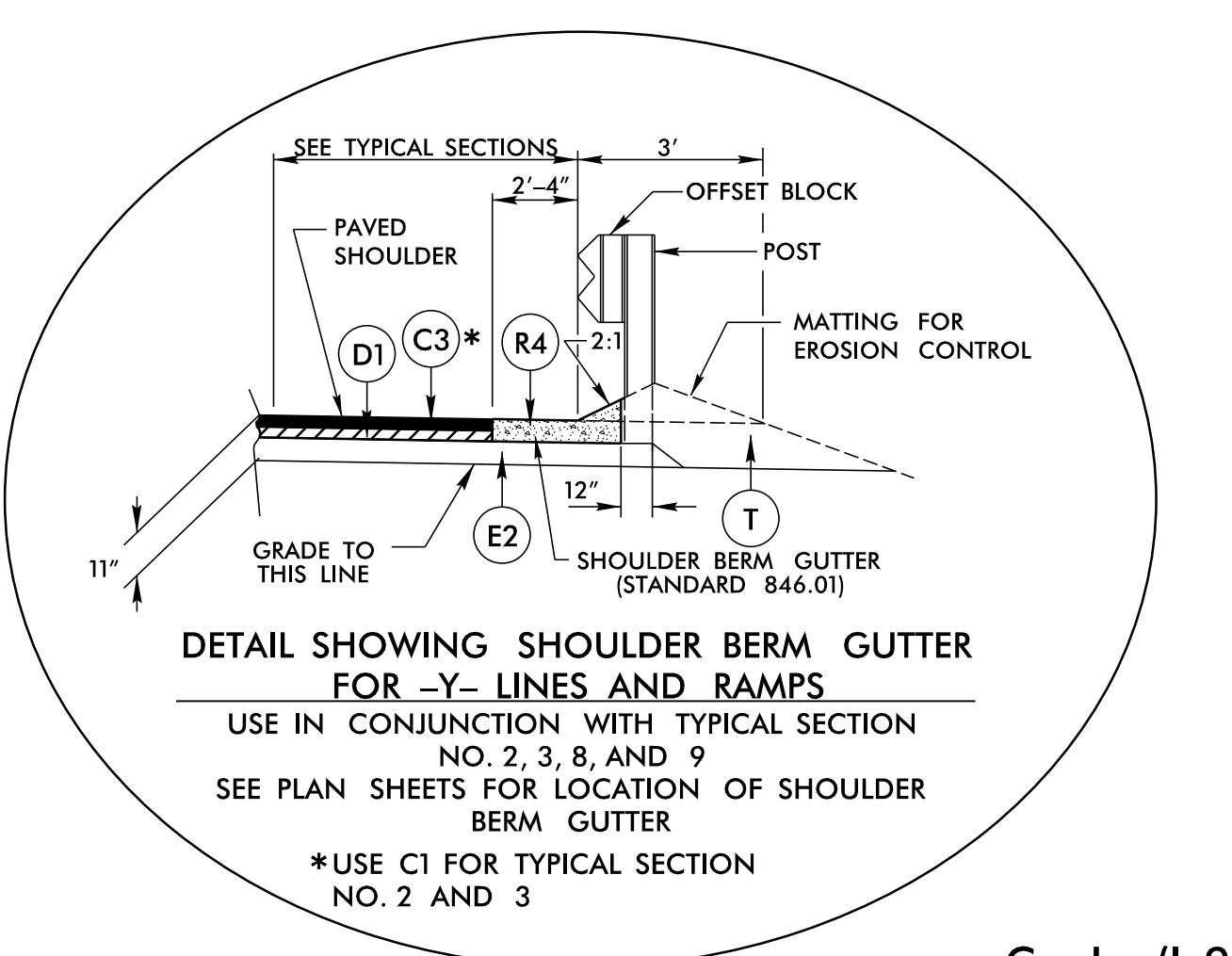
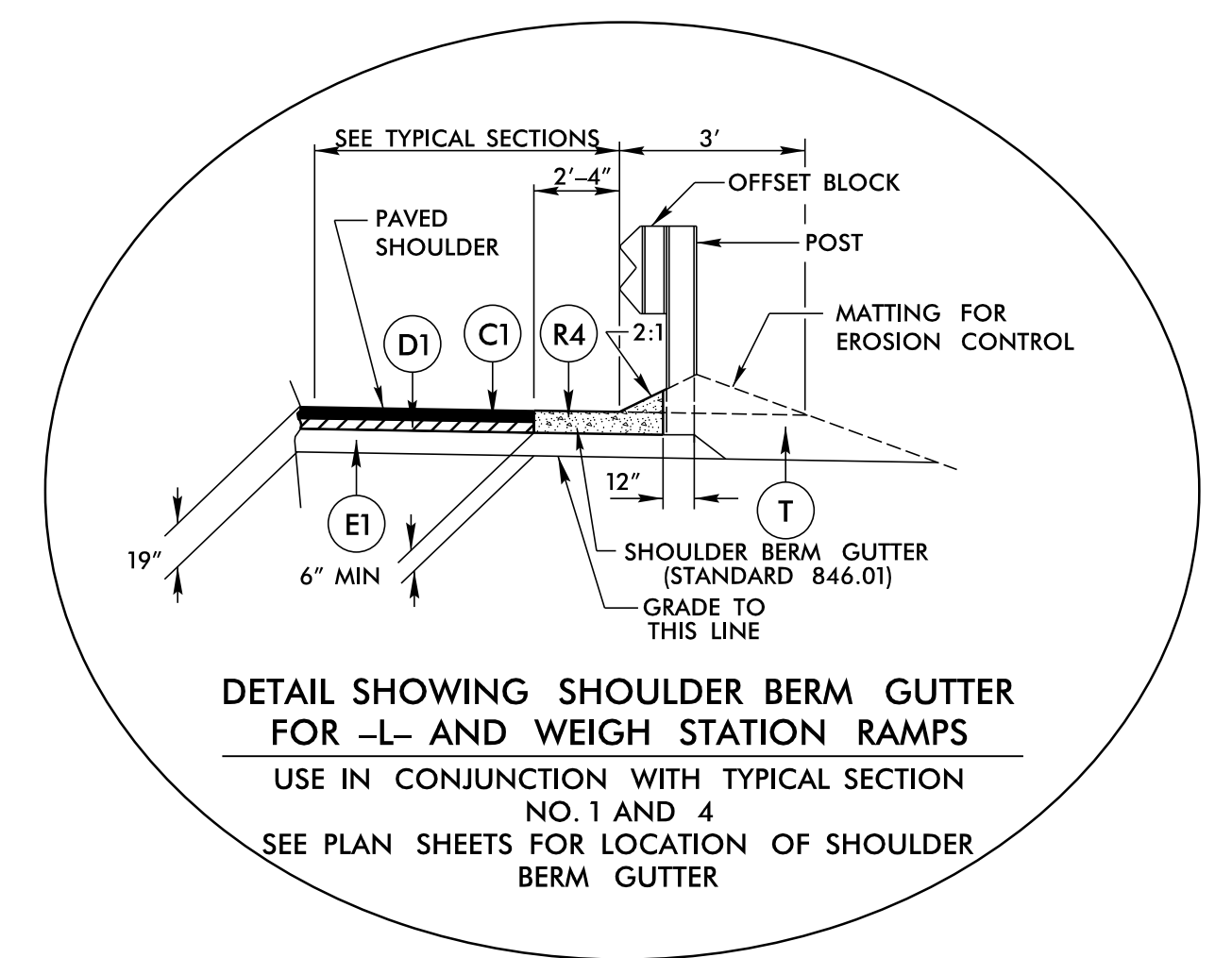

TYPICAL SECTION NO. 1
-L- STA. 67+00.00 TO 495+00
SEE PLANS FOR AUXILIARY LANE LOCATIONS
WEDGING DETAIL W1 IS TO BE USED WHEN THE WEDGING DEPTH IS LESS THAN 5.5"
WEDGING DETAIL W2 IS TO BE USED WHEN THE WEDGING DEPTH EXCEEDS 5.5"

*USE SINGLE SLOPE CONCRETE BARRIER FROM 67+00.00 TO +/-95+24 TIE TO I-6064 AT 67+00.00

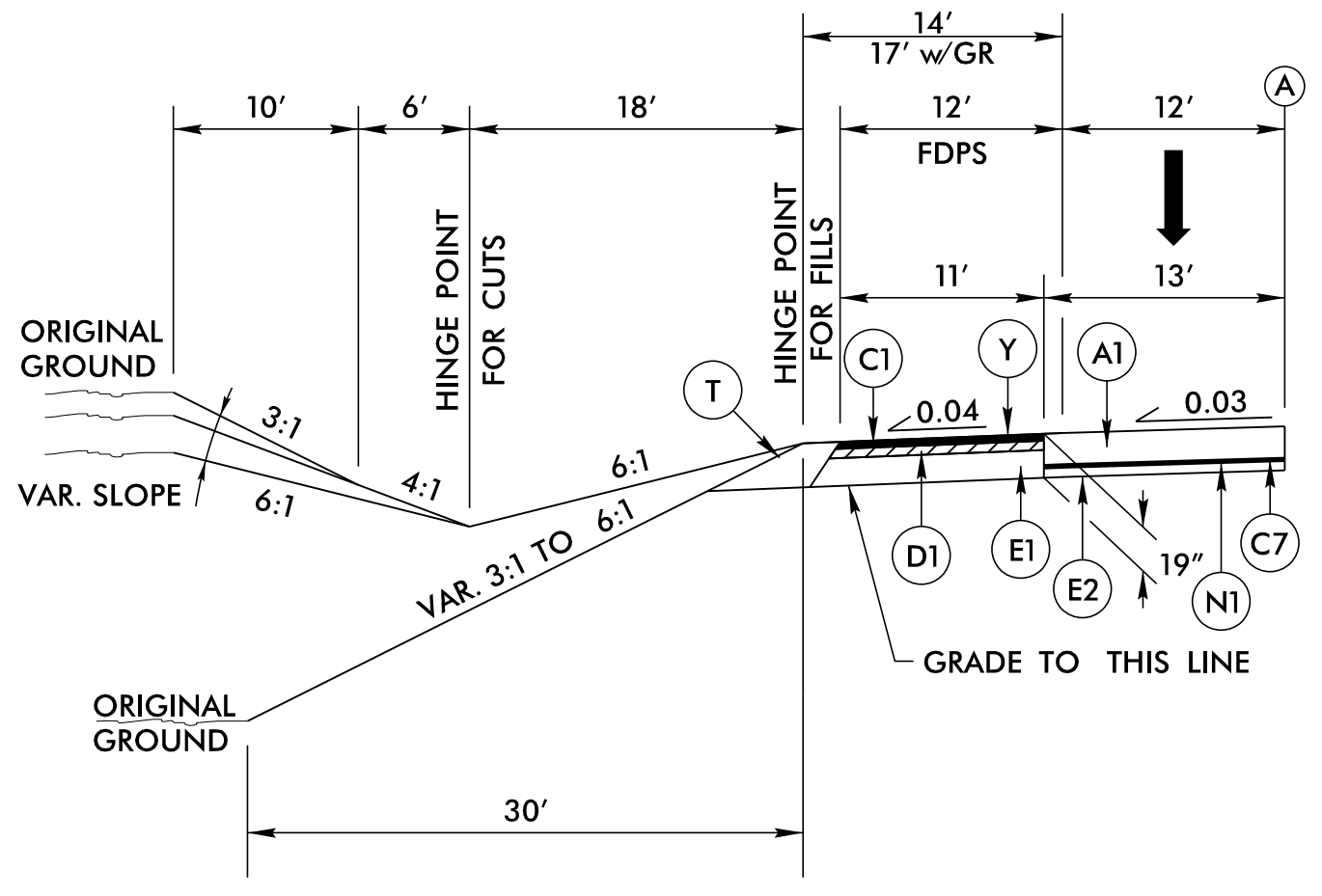

PARTIAL TYPICAL SECTION NO. 1A
-L- NB STA. 150+00.00 TO 195+00.00
-L- SB STA. 274+00.00 TO 299+00.00

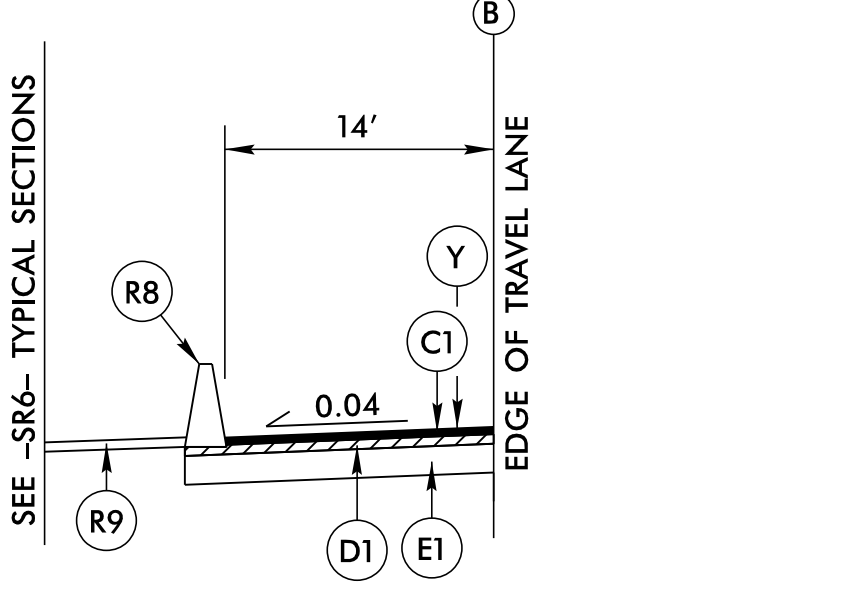

PARTIAL TYPICAL SECTION NO. 1B
-L- STA. 67+00.00 TO 85+71.93 LT

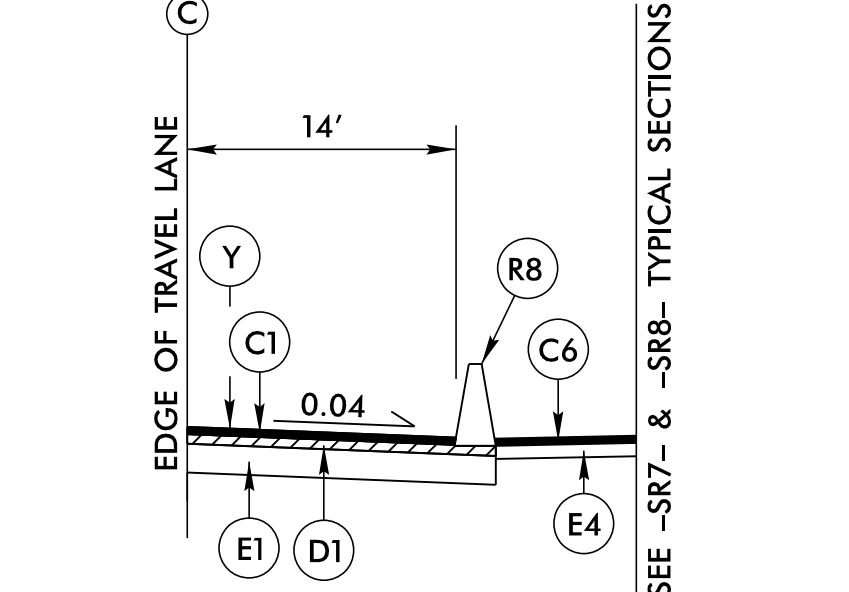

PARTIAL TYPICAL SECTION NO. 1C
-L- STA. 67+00.00 TO 83+44.00 RT

NOTE: MIRROR PARTIAL TYPICAL SECTION FOR RIGHT SIDE

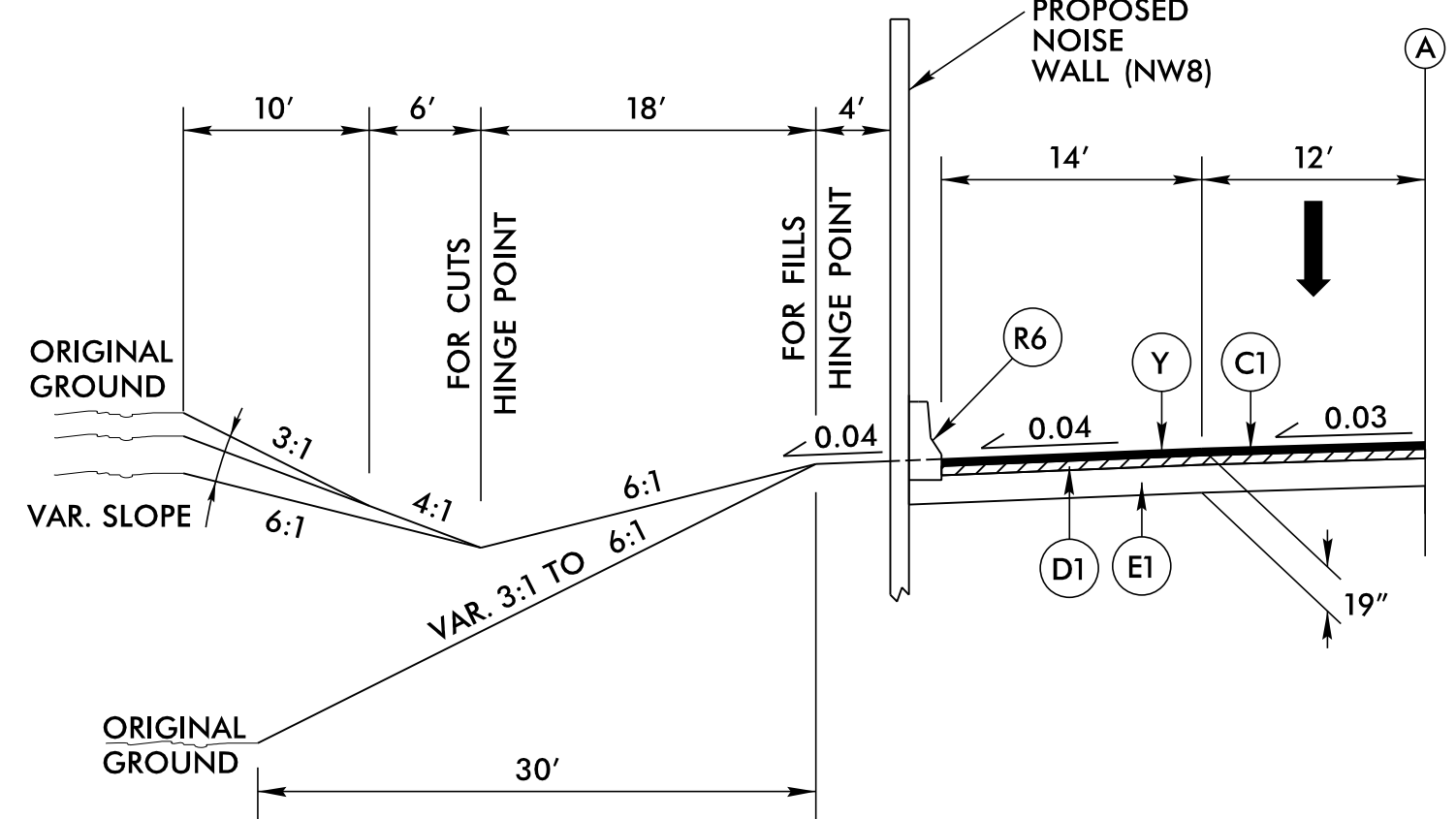

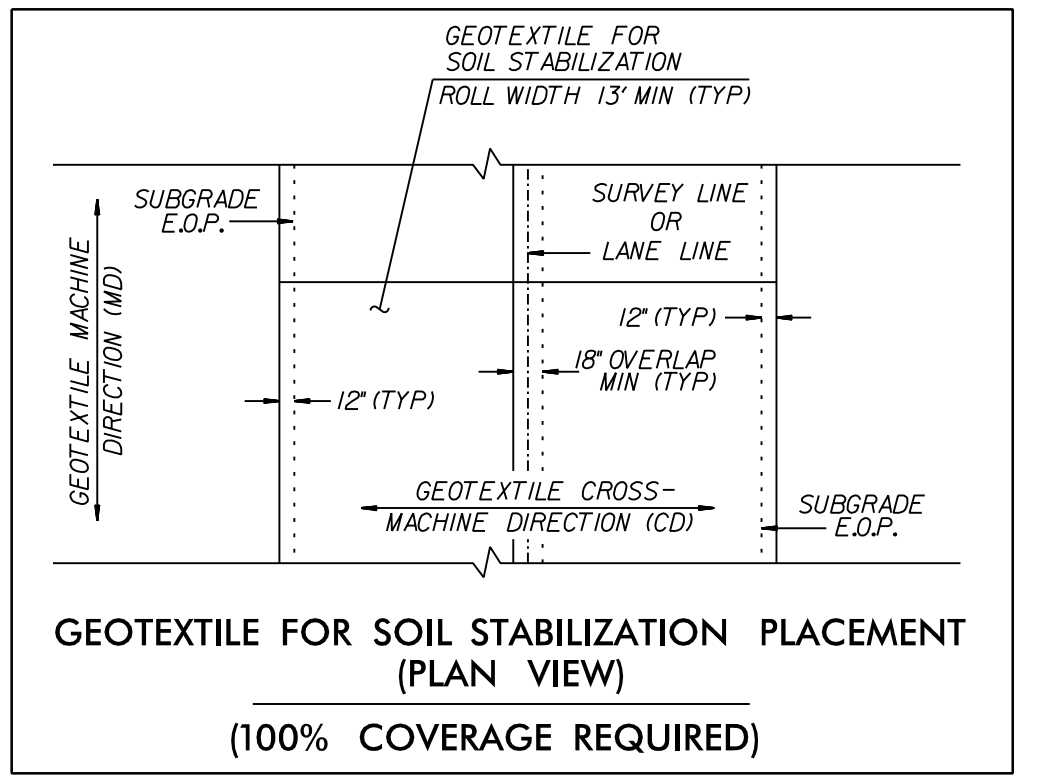

PARTIAL TYPICAL SECTION NO. 1E
-L- STA. 305+88.00 TO 308+93.55 LT

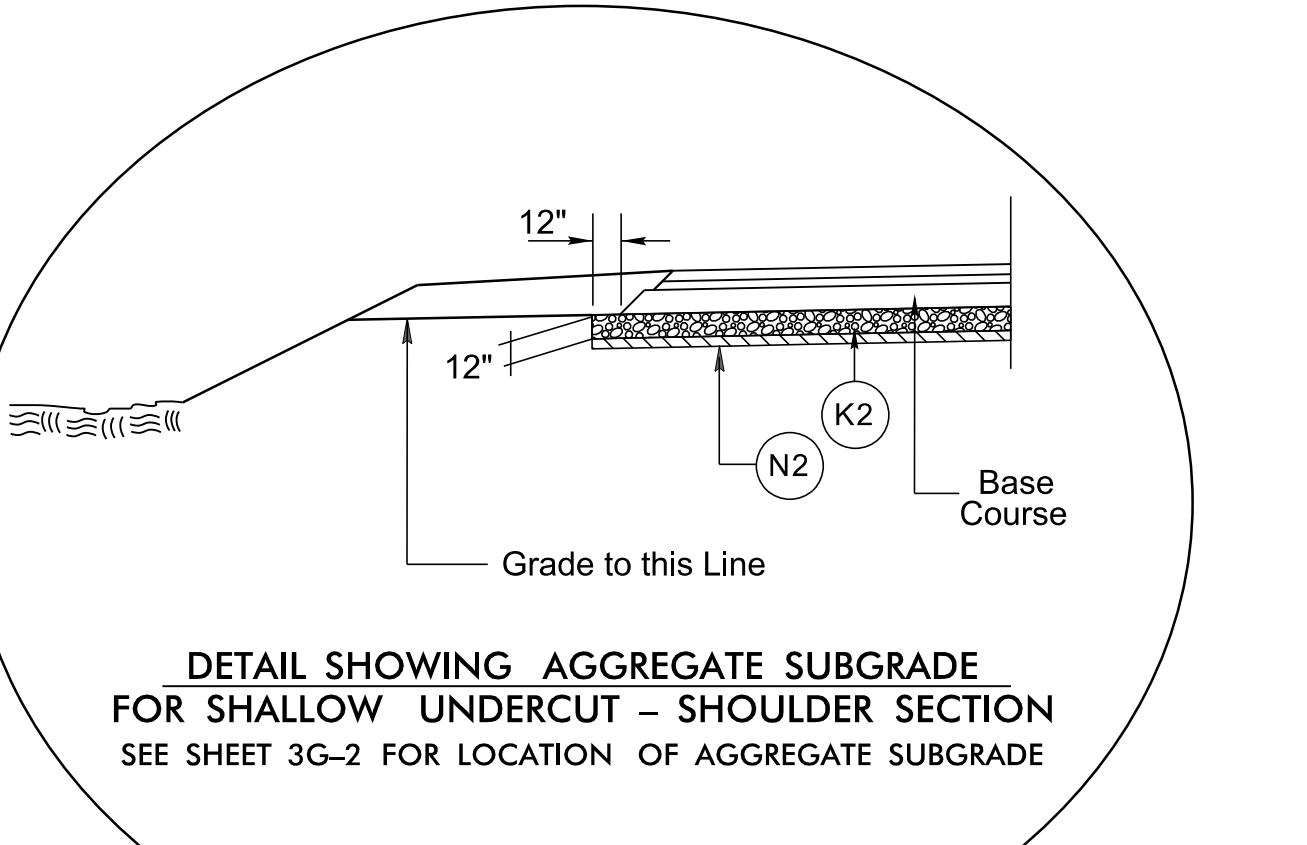

GEOTEXTILE FOR SOIL STABILIZATION PLACEMENT (PLAN VIEW)
(100% COVERAGE REQUIRED)

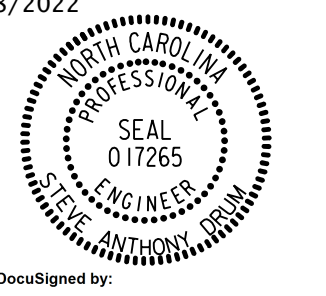
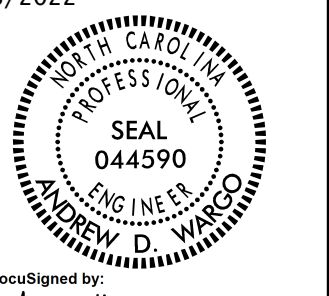

DETAIL SHOWING AGGREGATE SUBGRADE FOR SHALLOW UNDERCUT - SHOULDER SECTION
SEE SHEET 3G-2 FOR LOCATION OF AGGREGATE SUBGRADE

PROJECT REFERENCE NO. 1-5987A	SHEET NO. 2A-2
RW SHEET NO.	
ROADWAY DESIGN ENGINEER 5/18/2022 	PAVEMENT DESIGN ENGINEER 5/18/2022 
<p>DOCUMENT NOT CONSIDERED FINAL UNLESS ALL SIGNATURES COMPLETED</p> <p>NV5 NV5 ENGINEERS & CONSULTANTS, INC. 7500 E. INDEPENDENCE BLVD, STE 100 CHARLOTTE, NC 28227 P: 704.537.7300 www.NV5.com NC License # F-13333</p> <p> 4700 FALLS OF NEUSE ROAD, SUITE 300 RALEIGH, NORTH CAROLINA - 27609 (919) 781-4626 VOICE (919) 781-4869 FAX NC License No. F-0105</p>	

- 2" MILLING LIMITS**
- L- STA. 67+00.00 TO 67+50.00
 - L- STA. 71+50.00 TO 73+00.00
 - L- STA. 78+50.00 TO 80+00.00
 - L- STA. 86+00.00 TO 87+00.00
 - L- STA. 93+00.00 TO 97+00.00
 - L- STA. 97+50.00 TO 101+00.00
 - L- STA. 106+50.00 TO 108+50.00
 - L- STA. 125+50.00 TO 128+50.00
 - L- STA. 142+50.00 TO 149+00.00
 - L- STA. 165+00.00 TO 167+50.00
 - L- STA. 171+50.00 TO 173+50.00
 - L- STA. 174+00.00 TO 175+00.00
 - L- STA. 180+50.00 TO 182+00.00
 - L- STA. 192+00.00 TO 194+50.00
 - L- STA. 227+00.00 TO 229+50.00
 - L- STA. 240+50.00 TO 241+50.00
 - L- STA. 242+00.00 TO 243+50.00
 - L- STA. 253+50.00 TO 258+50.00
 - L- STA. 264+00.00 TO 266+00.00
 - L- STA. 270+50.00 TO 272+50.00
 - L- STA. 291+00.00 TO 292+50.00
 - L- STA. 296+00.00 TO 298+00.00
 - L- STA. 314+00.00 TO 316+00.00
 - L- STA. 322+00.00 TO 324+50.00
 - L- STA. 330+00.00 TO 332+50.00
 - L- STA. 365+60.00 TO 367+50.00
 - L- STA. 384+30.00 TO 388+00.00
 - L- STA. 395+40.00 TO 398+20.00
 - L- STA. 412+80.00 TO 416+58.00
 - L- STA. 436+80.00 TO 439+50.00
 - L- STA. 446+30.00 TO 449+70.00
 - L- STA. 493+80.00 TO 495+00.00

SEE SHEETS 2B-6 AND 2B-7 FOR SINGLE SLOPE CONCRETE BARRIER DETAILS