

**This electronic collection of documents is provided
for the convenience of the user
and is Not a Certified Document –**

**The documents contained herein were originally issued
and sealed by the individuals whose names and license
numbers appear on each page, on the dates appearing
with their signature on that page.**

**This file or an individual page
shall not be considered a certified document.**

T.I.P.: A-0009CB

**STATE OF NORTH CAROLINA
DEPARTMENT OF TRANSPORTATION**

**SIGNING PLAN
GRAHAM COUNTY**

**LOCATION: NC 143 FROM SR 1223 (BEECH CREEK RD) TO
0.5 MI NORTH OF APPALACHIAN TRAIL**

<small>TIP NO.</small> A-0009CB	<small>SHEET NO.</small> SIGN-1
<small>APPROVED:</small> <small>DocuSigned by: Jimmy Terry FD36F3882E4HD0</small>	
<small>DATE:</small> 7/27/2022	
<small>DOCUMENT NOT CONSIDERED FINAL UNLESS ALL SIGNATURES COMPLETED</small>	

ROADWAY STANDARD DRAWING

THE FOLLOWING ROADWAY STANDARDS AS APPEAR IN "ROADWAY STANDARD DRAWINGS" - PROJECT SERVICES UNIT - N.C. DEPARTMENT OF TRANSPORTATION - RALEIGH, N.C., DATED JANUARY 2018 ARE APPLICABLE TO THIS PROJECT AND BY REFERENCE HEREBY ARE CONSIDERED A PART OF THESE PLANS:

<u>STD. NO.</u>	<u>TITLE</u>
901.50	ARROWS AND SHIELDS
903.10	GROUND MOUNTED SIGN SUPPORTS
904.10	ORIENTATION OF GROUND MOUNTED SIGNS
904.50	MOUNTING OF TYPE 'D', 'E' AND 'F' SIGNS ON 'U' CHANNEL POSTS

GENERAL NOTES

- . SIGNS FURNISHED BY STATE
- . CONFIRM IN WRITING AT LEAST 4 MONTHS IN ADVANCE, THE ACTUAL DATE THE DEPARTMENT FURNISHED SIGNS WILL BE REQUIRED.
- . ALL TYPE 'D' SIGNS SHALL BE MOUNTED ON TWO U-CHANNEL POSTS UNLESS OTHERWISE INDICATED ON THE PLANS.
- . IF REMOVAL OR RELOCATION OF SIGNS ON PRIVATE STREET (NON-STATE MAINTAINED) IS REQUIRED DUE TO CONSTRUCTION, THE CONTRACTOR SHALL INFORM THE ENGINEER. THE WORK WILL BE COMPLETED BY OTHERS.
- . WHEN NOT STATIONED OR DIMENSIONED ON PLANS, ALL 'E' AND 'F' SIGNS SHALL BE FIELD LOCATED BY THE ENGINEER
- . ALL EXISTING SIGNS ON "U" CHANNEL POST WITHIN THE PROJECT LIMITS SHALL BE REMOVED AND DISPOSED OF UNLESS OTHERWISE NOTED ON PLANS.
- . WHEN EXISTING SIGNS ARE REMOVED AND INSTALLED ON NEW SUPPORTS, THE RE-ERECTION SHALL IMMEDIATELY FOLLOW THE REMOVAL.
- . THE BACKGROUND FOR TYPE E & F SIGNS SHALL BE TYPE C REFLECTIVE SHEETING.
- . SEE ROADWAY PLANS FOR GUARD/GUIDE RAIL DETAILS.

SUMMARY OF QUANTITIES

ITEM NO.		ITEM DESCRIPTION	QUANTITY	UNIT
DESC. NO.	SECT. NO.			
4072000000	903	SUPPORTS, 3 LB STEEL U-CHANNEL	1,140	L.F.
4096000000	904	SIGN ERECTION, TYPE D	4	EA.
4102000000	904	SIGN ERECTION, TYPE E	69	EA.
4108000000	904	SIGN ERECTION, TYPE F	2	EA.
4116100000	904	SIGN ERECTION, RELOCATE SIGN TYPE D (GROUND MOUNTED)	2	EA.
4116100000	904	SIGN ERECTION, RELOCATE SIGN TYPE E (GROUND MOUNTED)	4	EA.
4116100000	904	SIGN ERECTION, RELOCATE LOGO TRAILBLAZERS (GROUND MOUNTED)	4	EA.
4155000000	907	DISPOSAL OF SIGN SYSTEM, U-CHANNEL	20	EA.
4192000000	907	DISPOSAL OF SUPPORT, U-CHANNEL	6	EA.

INDEX

<u>SHEET NO.</u>	<u>DESCRIPTION</u>
SIGN-1	TITLE SHEET
SIGN-1A	REVISED SIGNING RSD (904.50 SHT 1 OF 2)
SIGN-2	TYPE "D" SIGNS
SIGN-3	TYPE "E" & "F" SIGNS
SIGN-4-12	EXISTING AND PROPOSED SIGNING PLAN SHEETS

PLAN SUBMITTED TO:

WANDA H. AUSTIN DIVISION ENGINEER, NCDOT DIVISION 14

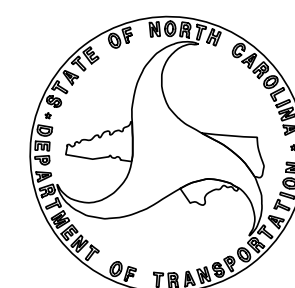

PLAN PREPARED BY: TGS ENGINEERS

JIMMY TERRY, PE PROJECT ENGINEER
SANDRA MELVIN DESIGN TECHNICIAN

TGS ENGINEERS
201 W. MARION ST
SHELBY, NC 28150
PH (704) 476-0003
CORP. LICENSE NO.: C-0275

TIP NO. SHEET NO.

DocuSign by: *Matthew V. Springer*

APPROVED: *Matthew V. Springer*

DATE: 6/23/2021

SEAL

STATE OF NORTH CAROLINA
DEPT. OF TRANSPORTATION
DIVISION OF HIGHWAYS
RALEIGH, N.C.

ENGLISH DETAIL DRAWING FOR
MOUNTING OF
TYPE 'D', 'E' AND 'F' SIGNS
ON 'U' CHANNEL POSTS

SHEET 1 OF 2
904D50

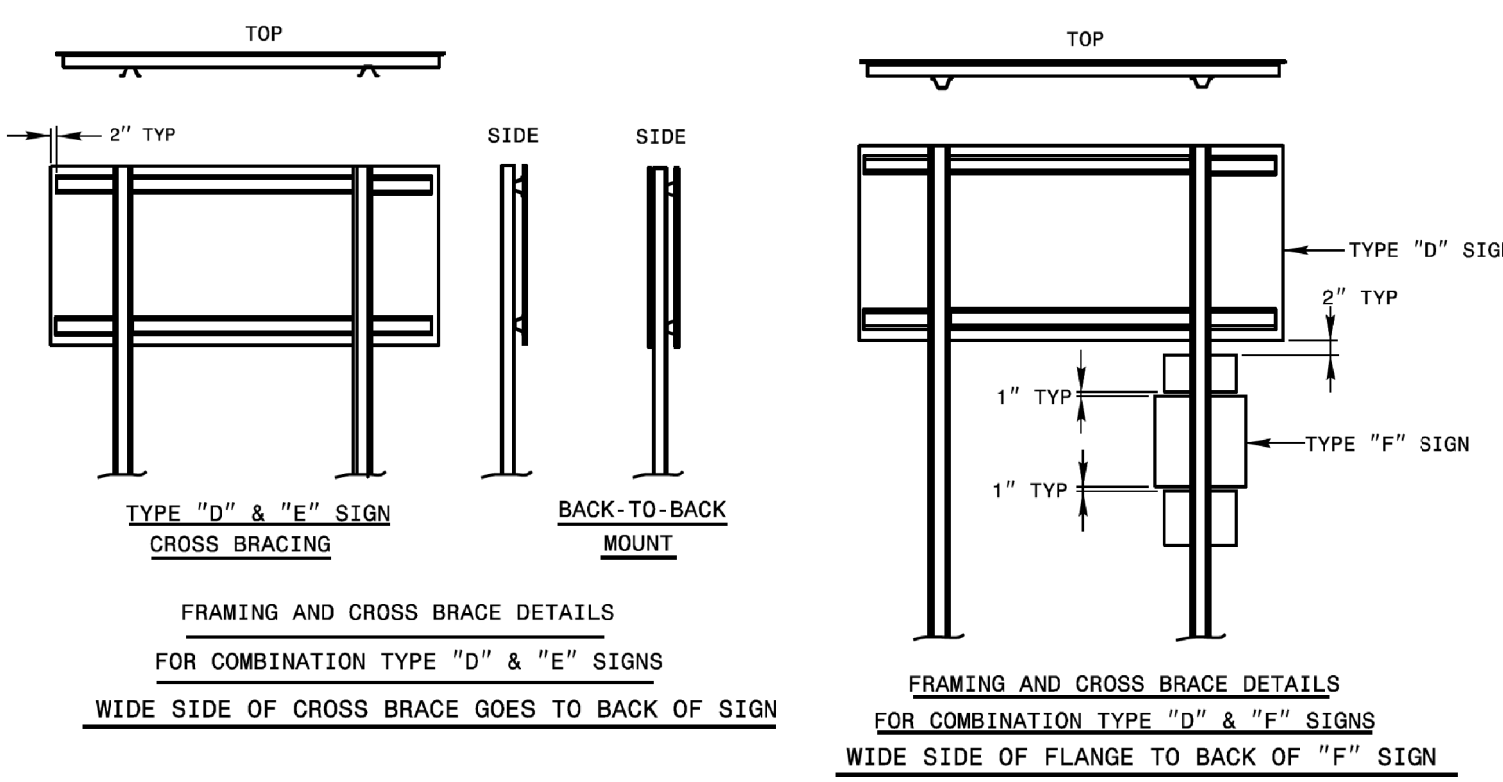
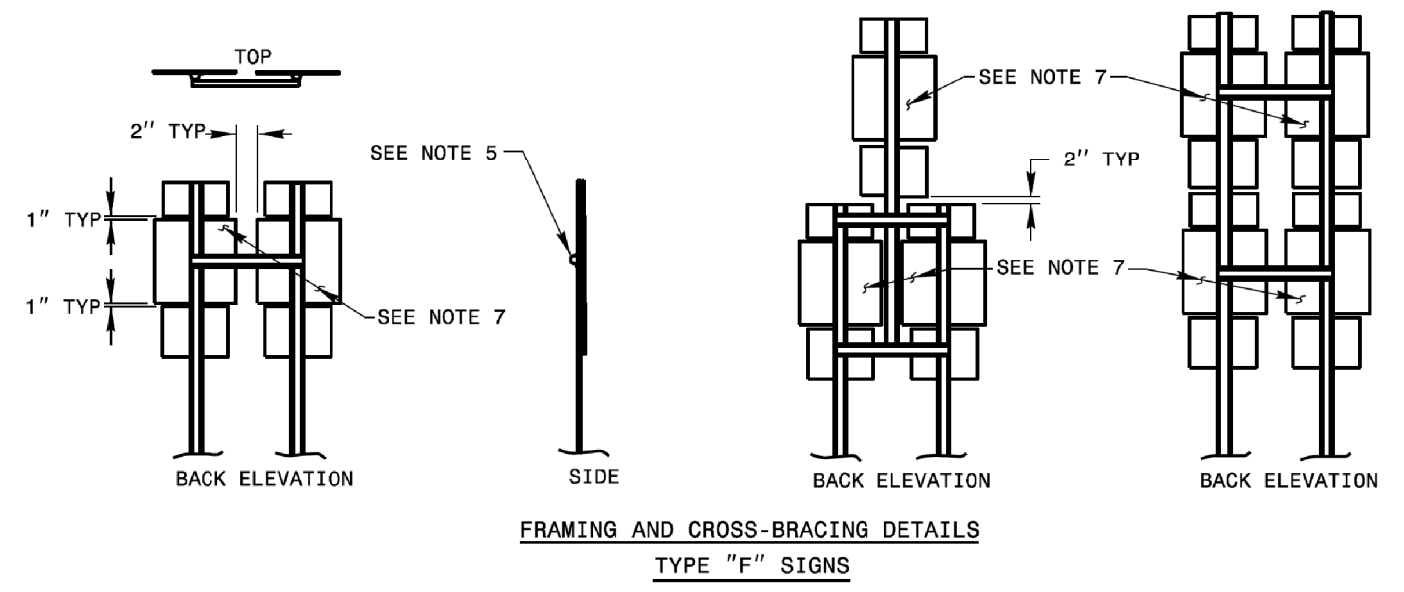
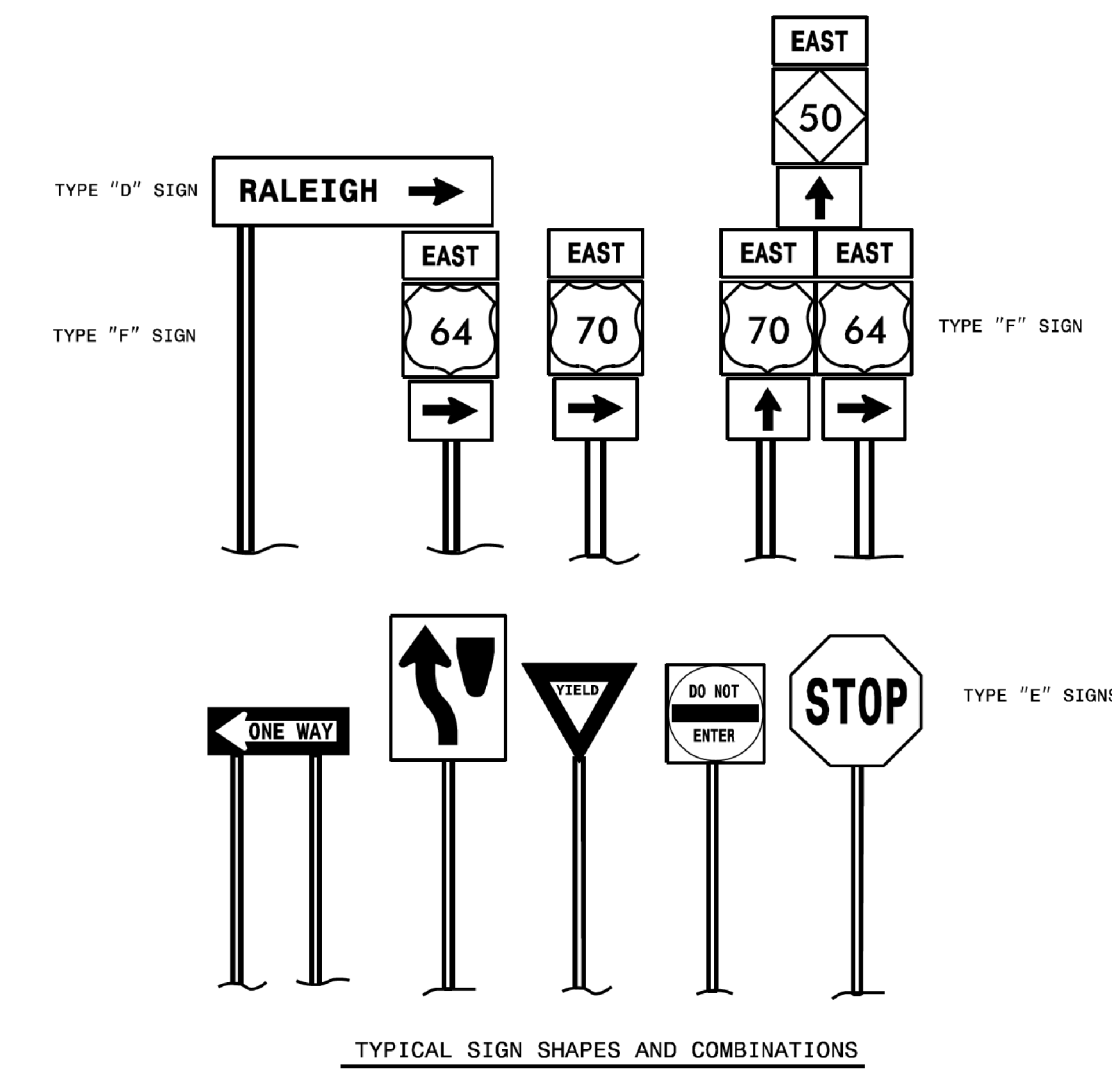
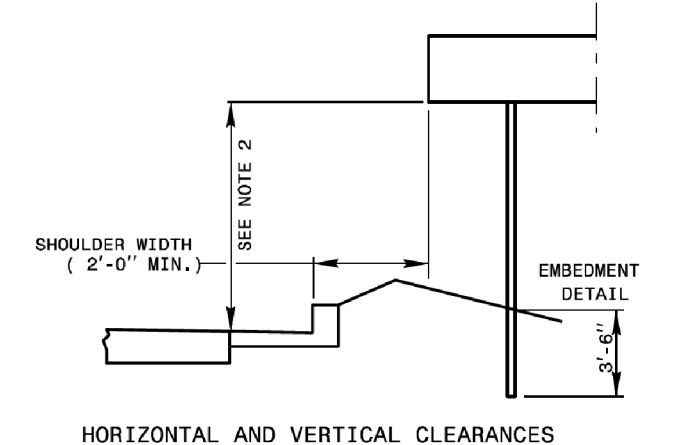
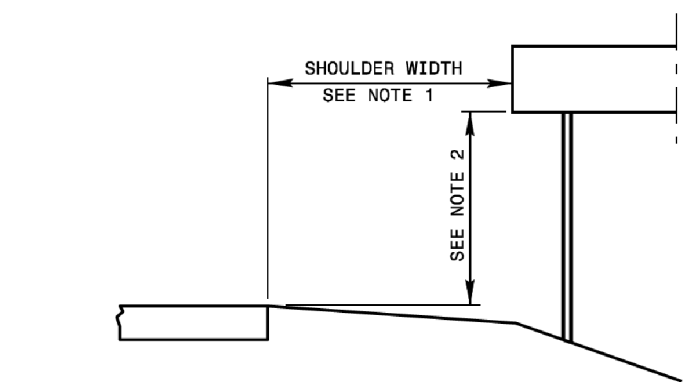

- NOTES:
- ERECT TYPE "D", "E", AND "F" SIGNS ON FREEWAYS WITH THE NEAR EDGE OF THE SIGN 20 FT. FROM THE TRAVEL LANE. ERECT ALL OTHER "D", "E", AND "F" SIGNS WITH THE NEAR EDGE OF THE SIGN AT THE EDGE OF THE SHOULDER BREAK (6 FT. MINIMUM CLEARANCE, 12 FT. DESIRABLE, FROM THE EDGE OF TRAVEL LANE), OR AS DIMENSIONED ON PLAN SHEETS.
 - ERECT TYPE "D", "E", AND "F" SIGNS WITH THE BOTTOM OF SIGN ASSEMBLY AT LEAST 7 FT. ABOVE THE EDGE OF THE TRAVEL LANE ON ROADS WITH 2 OR MORE LANES IN THE SAME DIRECTION AND AT LEAST 5 FT. ON OTHER ROUTES. THE VERTICAL CLEARANCE IS 7 FT. WHERE REQUIRED FOR PEDESTRIAN TRAFFIC AND/OR PARKED VEHICLES.
 - THE VERTICAL DIMENSION BETWEEN MOUNTING HOLE CENTERS ON ALL TYPES "D", "E", AND "F" SIGNS IS 30" MAXIMUM. THE VERTICAL AND HORIZONTAL DIMENSIONS BETWEEN MOUNTING HOLES IS TO THE WHOLE INCH. EACH SIGN PANEL HAS A MINIMUM OF 2 BOLTS PER SUPPORT.
 - ATTACH SIGN W/ 5/16" HEX HEAD BOLT, NYLON WASHER, SHIM, FLAT WASHER, LOCK WASHER, HEX NUT NO BUCKLING OF THE SIGN WILL BE PERMITTED. SEE ASSEMBLY DETAIL SHEET# 2 OF 904.50.
 - FURNISH AND INSTALL CROSS-BRACING AS SHOWN IN DETAIL. PAINT ENDS OF CROSS BRACES W/ APPROVED. ZINC PAINT
 - INSTALL POST AND CROSS-BRACING WITH THE WIDE SIDE OF THE FLANGE TOWARD THE BACK OF SIGN(S) FOR COMBINATION TYPE "D" AND "F" SIGNS.
 - THE SHIELD HEIGHTS IN THESE ASSEMBLIES CAN NOT BE LARGER THAN 24".
 - IF SIGN ASSEMBLIES REQUIRE MORE THAN TWO U-CHANNEL SUPPORTS, THE SUPPORTS SHALL BE PLACED A MINIMUM OF 4 FT. BETWEEN POSTS. NO MORE THAN TWO POSTS SHALL FALL WITHIN 7 FT. PATH, OR THE SIGN ASSEMBLY MUST BE PLACED BEHIND BARRIER PROTECTION.

STATE OF NORTH CAROLINA
DEPT. OF TRANSPORTATION
DIVISION OF HIGHWAYS
RALEIGH, N.C.

ENGLISH DETAIL DRAWING FOR
MOUNTING OF
TYPE 'D', 'E' AND 'F' SIGNS
ON 'U' CHANNEL POSTS

SHEET 1 OF 2
904D50

REVISED SIGNING
ROADWAY STANDARD DRAWING

5/23/2022 5:11:00 PM X:\NCDOT\A-0009\Traffic\Signing\A-0009CB\CADD\Quantities & GM_Signs\A-0009CB_Sgn_SGN_Revise RSD.dgn User:smelvin

6/18/2021 S:\NCDOT\Standards Group\Standards and Drawings\Drawings\2018_Standard Dwg\0450_sgn_sht01_uchannel.post_6-21.dgn User:stokes

6-21

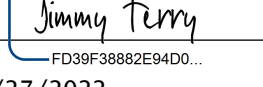
APPROVED: 
DocuSigned by:
Jimmy Terry
F038F3882E94D0...

DATE: 7/27/2022

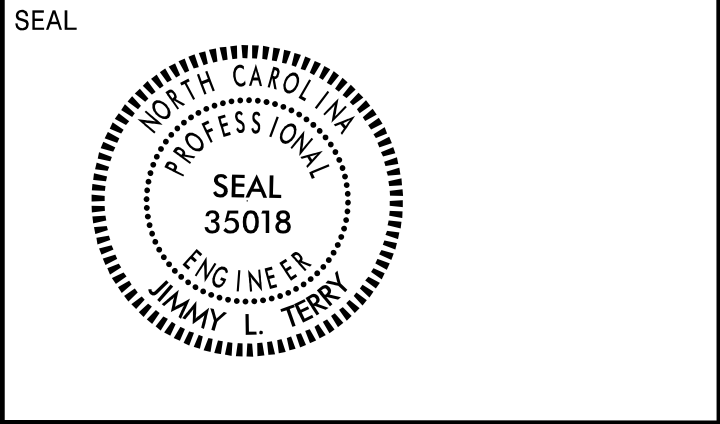

**DOCUMENT NOT CONSIDERED FINAL
UNLESS ALL SIGNATURES COMPLETED**

TGS ENGINEERS
 201 W. MARION ST., STE 200
 SHELBY, NC 28150
 PH (704) 476-0003
 CORP. LICENSE NO.: C-0275

SIGN NUMBER: 301, 302 TYPE: D QUANTITY: 1 SIGN WIDTH: 3'-6" HEIGHT: 3'-6" TOTAL AREA: 12.3 Sq.Ft. BORDER TYPE: FLUSH RECESS: 0" WIDTH: 0.75" RADII: 3" NO. Z BARS: LENGTH:	BACKG COLOR: Green COPY COLOR: White SYMBOL X Y WID HT MAT'L: 0.125" (3.2 mm) ALUMINUM	DESIGN BY: SGM PROJECT ID: A-0009CB LOCATION: GRAHAM CO - NC 143 CHECKED BY: Feb 01, 2022 DIV: 14
---	---	--

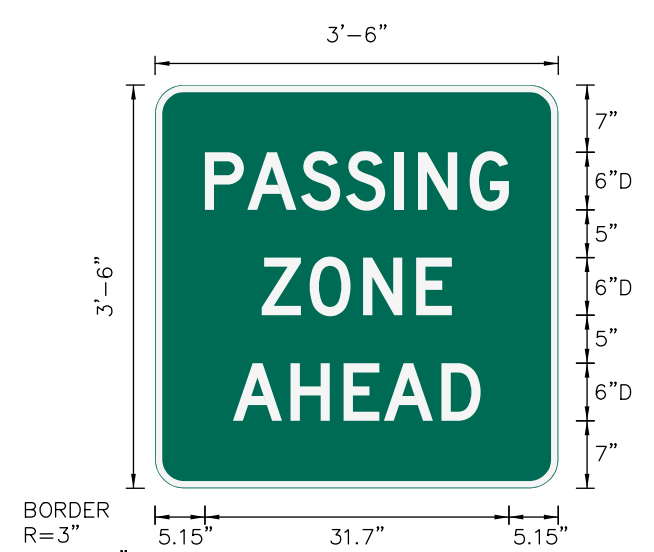

USE NOTES: 1,2
 1. Legend and border(except those that are colored black) shall be direct applied Grade C sheeting.
 2. Background shall be Grade C reflective sheeting.

Spacing Factor is 1 unless specified otherwise

LETTER POSITIONS

Letter spacings are to start of next letter											Series/Size Text Length
	P	A	S	S	I	N	G				D 2000 31.7
5.2	4.4	5.6	4.7	5.1	2.4	5.4	4.1	5.1			
	Z	O	N	E							D 2000 19.8
11.1	5	5.6	5.5	3.7	11.1						
	A	H	E	A	D						D 2000 25.8
8.1	6	5.5	4.2	6	4.1	8.1					

FILENAME: A-0009CB_Sgn_Sgn_Type_D NORTH CAROLINA D.O.T. SIGN DETAIL

SIGN NUMBER: 303, 304 TYPE: D QUANTITY: 1 SIGN WIDTH: 6'-0" HEIGHT: 2'-0" TOTAL AREA: 12.0 Sq.Ft. BORDER TYPE: FLUSH RECESS: 0" WIDTH: 0.75" RADII: 2.25" NO. Z BARS: LENGTH:	BACKG COLOR: Green COPY COLOR: White SYMBOL X Y WID HT MAT'L: 0.125" (3.2 mm) ALUMINUM	DESIGN BY: SGM PROJECT ID: A-0009CB LOCATION: GRAHAM CO - NC 143 CHECKED BY: Feb 28, 2022 DIV: 14
--	---	--



USE NOTES: 1,2
 1. Legend and border(except those that are colored black) shall be direct applied Grade C sheeting.
 2. Background shall be Grade C reflective sheeting.

Spacing Factor is 1 unless specified otherwise

LETTER POSITIONS

Letter spacings are to start of next letter													Series/Size Text Length	
	S	T	E	C	O	A	H	G	A	P			E 2000 64.2	
3.9	5.5	5.5	5.5	6.1	5.9	7.1	4.9	6	5.7	7.1	4.9	3.9		
	E	L	E	V		3	1	6	5	F	T		E 2000 42.1	
14.9	3.8	3.7	3.4	3.7	4	3.9	2.1	3.9	3.2	4	3.3	3	14.9	

FILENAME: A-0009CB_Sgn_Sgn_Type_D NORTH CAROLINA D.O.T. SIGN DETAIL

7/27/2022
 X:\NC\001\A-0009\Traffic\Signing\A-0009CB\CADD\Quantities & GM_Signs\A-0009CB_Sgn_Sgn_Type_D.dgn
 User:smelvrn

TYPE "D" SIGNS

APPROVED: *Jimmy Terry*
DATE: 7/27/2022

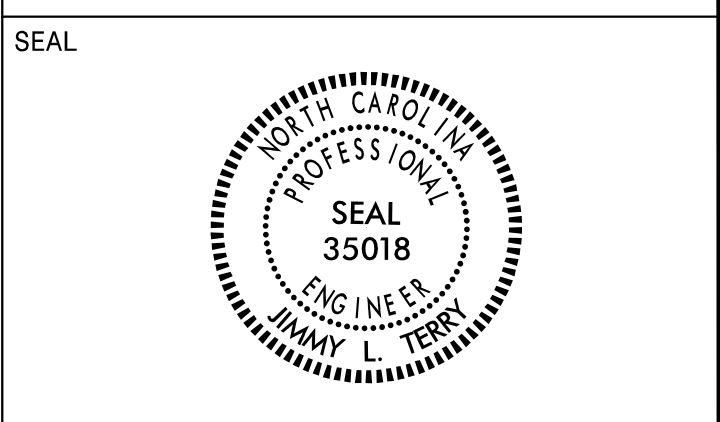

DOCUMENT NOT CONSIDERED FINAL UNLESS ALL SIGNATURES COMPLETED

TGS ENGINEERS
201 W. MARION ST. STE 200
SHELBY, NC 28150
PH (704) 476-0003
CORP. LICENSE NO.: C-0275

401 QUANTITY REQ'D 2

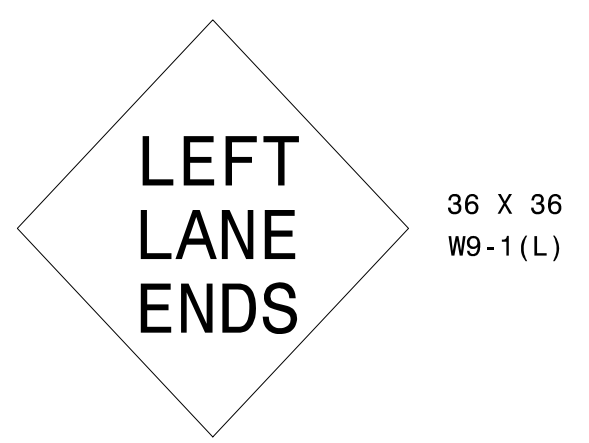

ONE "U" POST PER SIGN

402 QUANTITY REQ'D 2

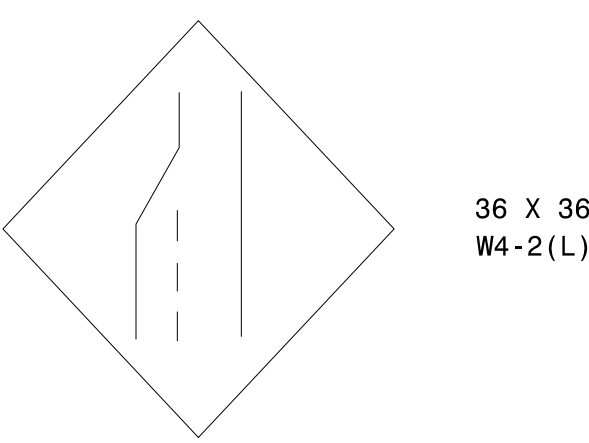

ONE "U" POST PER SIGN

403 QUANTITY REQ'D 2

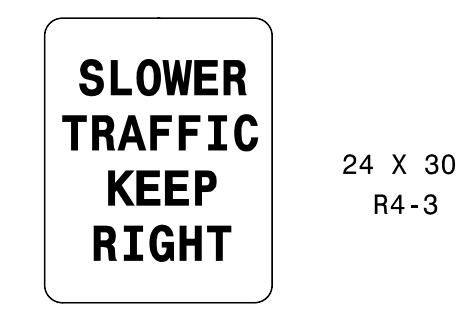

ONE "U" POST PER SIGN

404 QUANTITY REQ'D 3

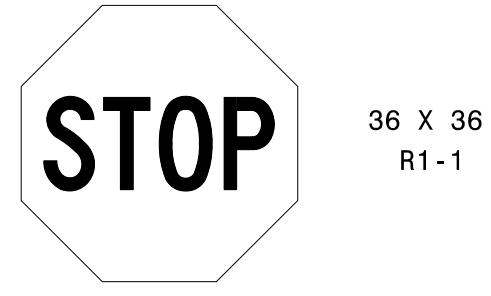

ONE "U" POST PER SIGN

405 QUANTITY REQ'D 1

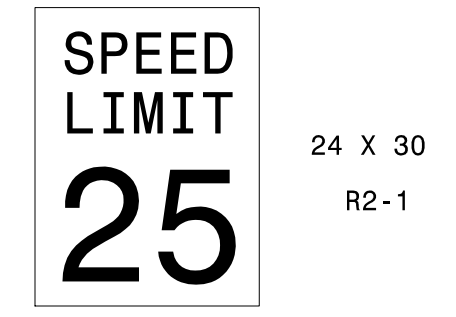

ONE "U" POST PER SIGN

406 QUANTITY REQ'D 2

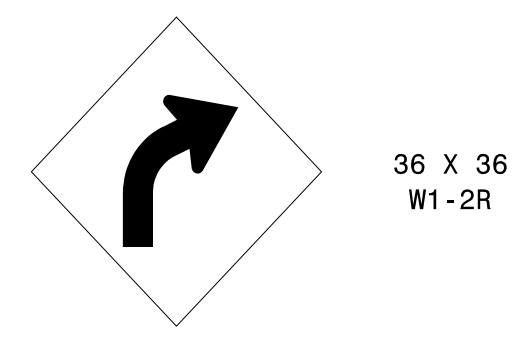

ONE "U" POST PER SIGN

407 QUANTITY REQ'D 4

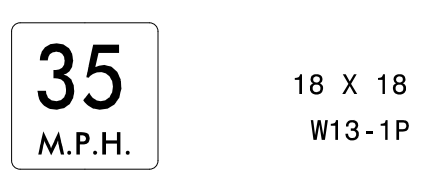

MOUNT BELOW SIGN 406 IN 2 INSTALLATIONS
MOUNT BELOW SIGN 411 IN 2 INSTALLATIONS

408 QUANTITY REQ'D 2

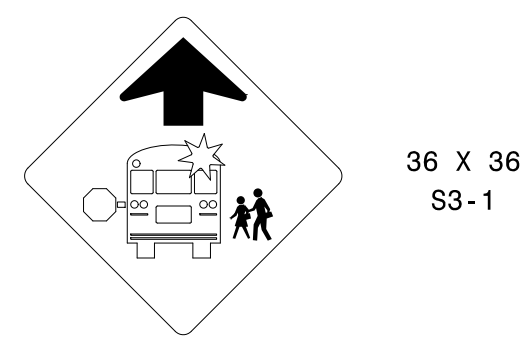

YELLOW/GREEN REFLECTIVE SHEETING
ONE "U" POST PER SIGN

409 QUANTITY REQ'D 1

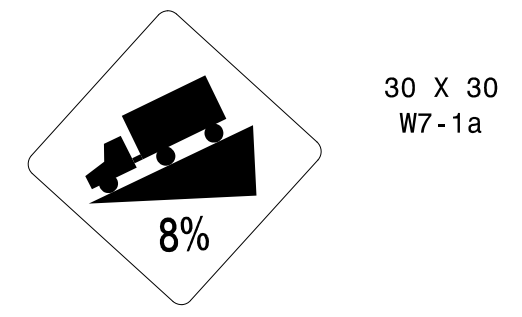

ONE "U" POST PER SIGN

410 QUANTITY REQ'D 1



MOUNT BELOW SIGN 409 IN 1 INSTALLATION

411 QUANTITY REQ'D 2

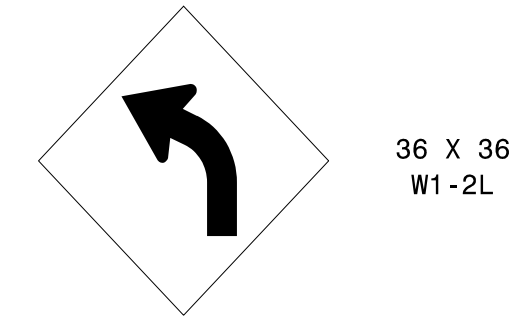

ONE "U" POST PER SIGN

412 QUANTITY REQ'D 2

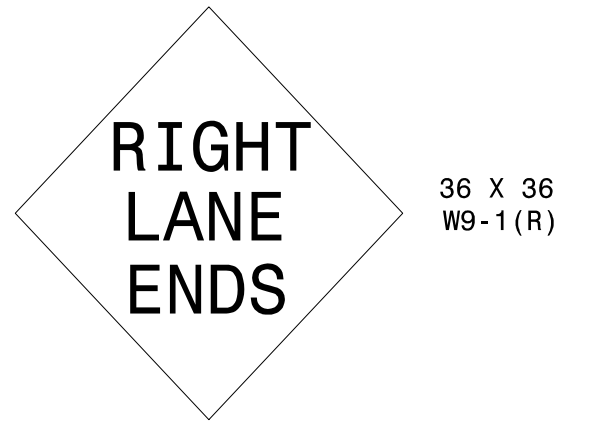

ONE "U" POST PER SIGN

413 QUANTITY REQ'D 2

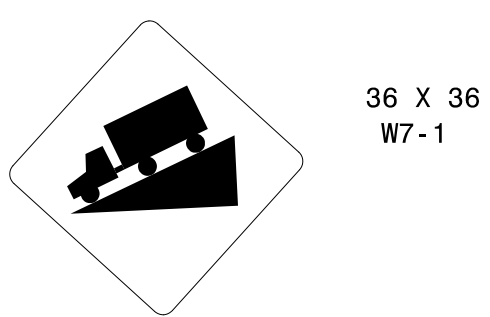

ONE "U" POST PER SIGN

414 QUANTITY REQ'D 1



MOUNT BELOW SIGN 413 IN 1 INSTALLATION

415 QUANTITY REQ'D 2

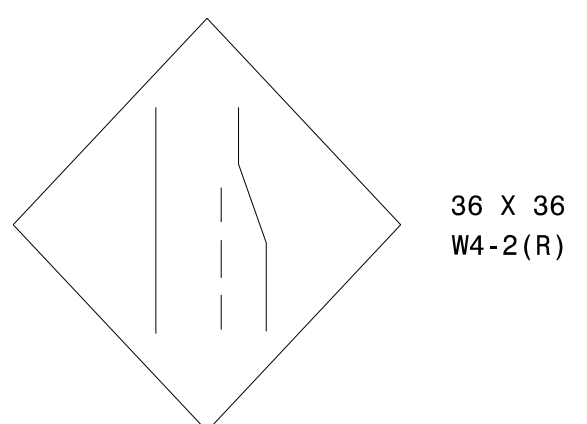

ONE "U" POST PER SIGN

416 QUANTITY REQ'D 1

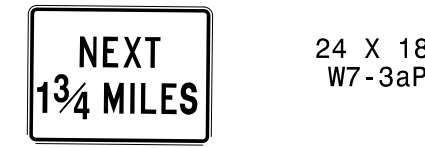

MOUNT BELOW SIGN 413 IN 1 INSTALLATION

417 QUANTITY REQ'D 1

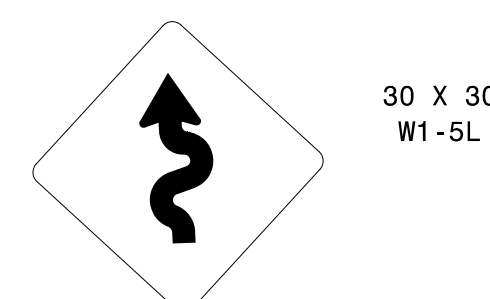

ONE "U" POST PER SIGN

418 QUANTITY REQ'D 1

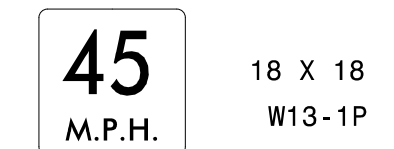

MOUNT BELOW SIGN 417 IN 1 INSTALLATIONS

419 QUANTITY REQ'D 1

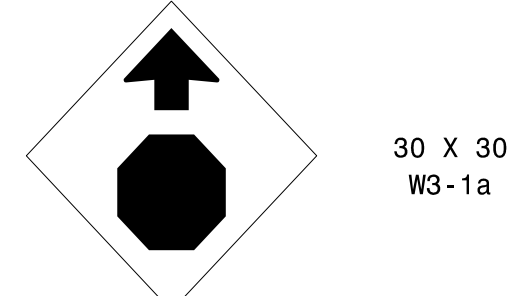

ONE "U" POST PER SIGN

420 QUANTITY REQ'D 17



ONE "U" POST PER SIGN

421 QUANTITY REQ'D 17



ONE "U" POST PER SIGN
MOUNT BACK TO BACK SIGN 420 IN 9 INSTALLATIONS

422 QUANTITY REQ'D 2



ONE "U" POST PER SIGN

501

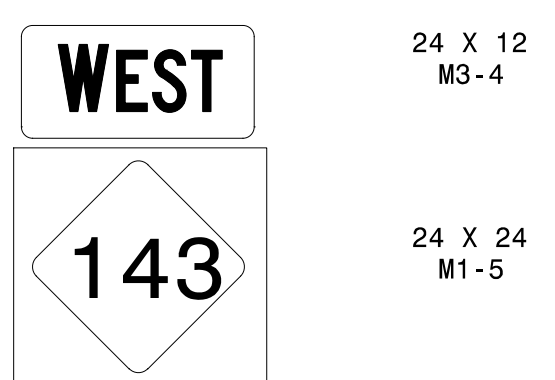

ONE "U" POST PER ASSEMBLY

502

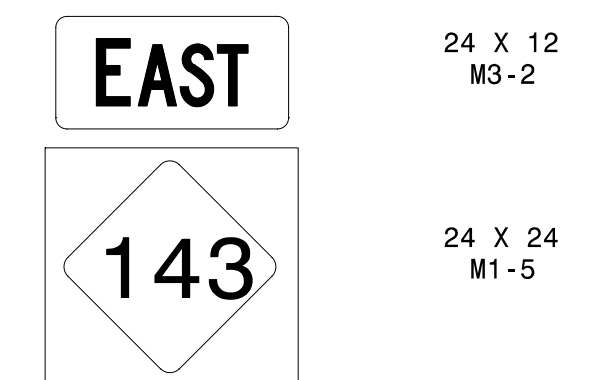



ONE "U" POST PER ASSEMBLY

TYPE "E" & "F" SIGNS

7/27/2022 X:\NCDOT\VA-0009\Traffic\Signing\VA-0009CB\CADD\Quantities & GM_Signs\VA-0009CB_Sgn_SGN_Sign03_Type E&F.dgn User:sme1vrv

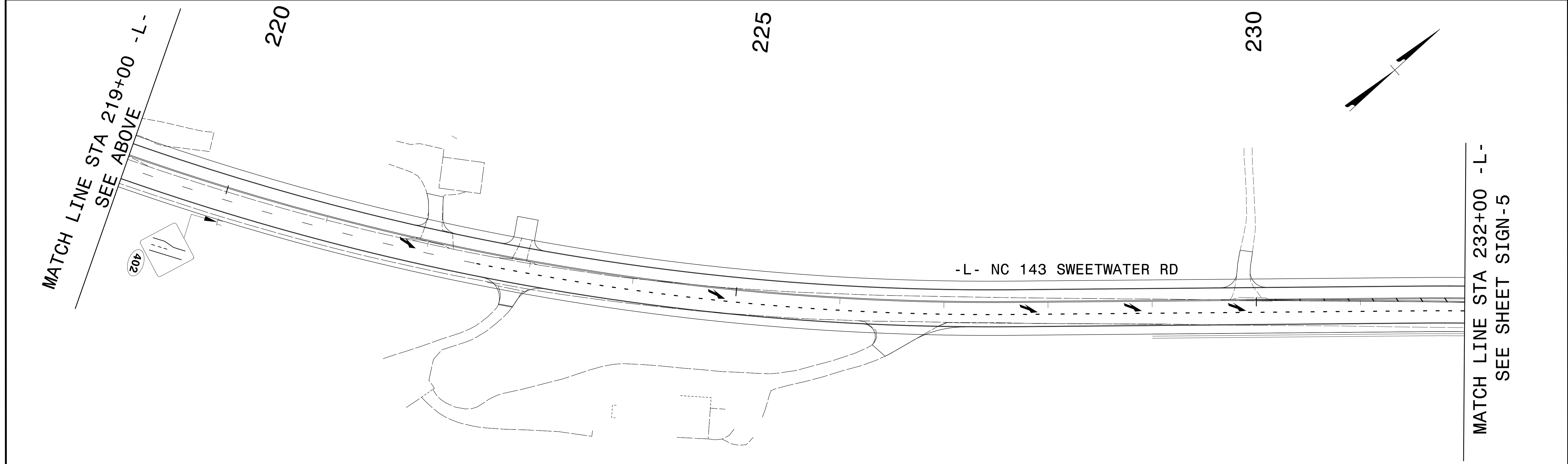
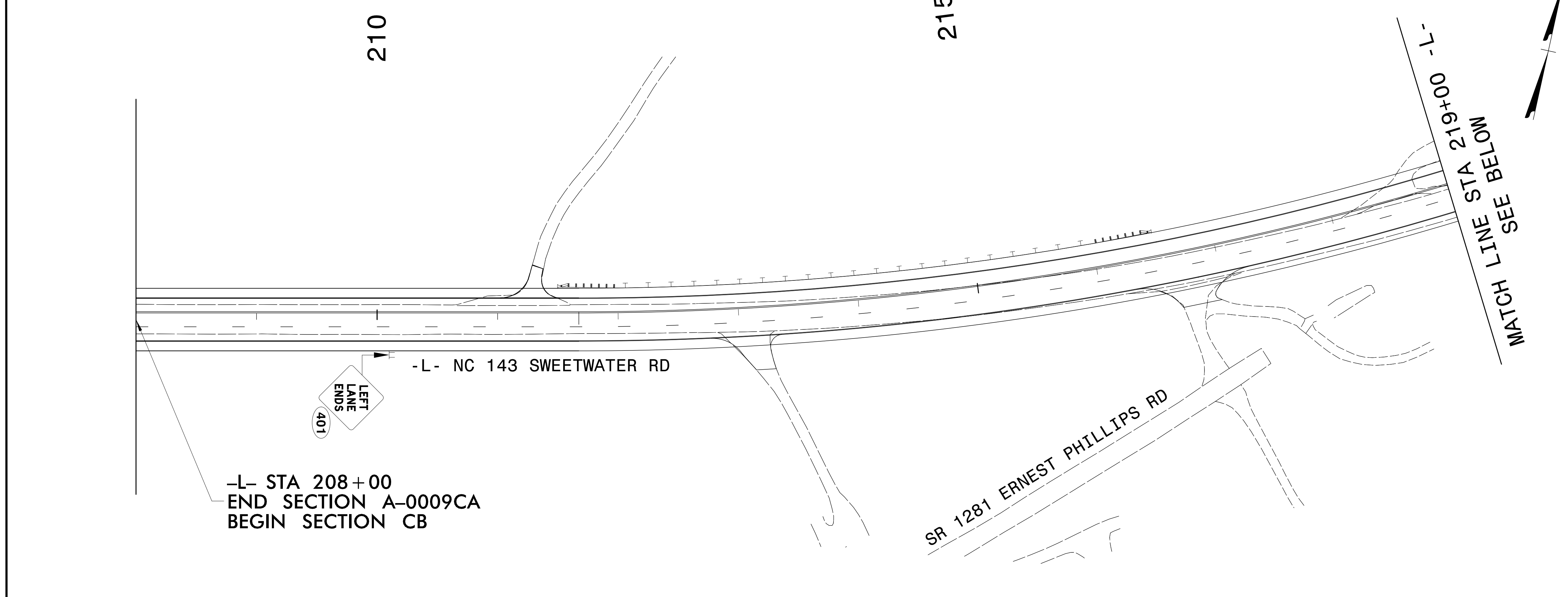
NO EXISTING SIGNS ON THIS SHEET

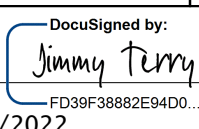

TIP NO. A-0009CB	SHEET NO. SIGN-4
APPROVED:  DocuSigned by: Jimmy Terry FD39F8882E84D0	
DATE: 7/27/2022	
SEAL	
	
DOCUMENT NOT CONSIDERED FINAL UNLESS ALL SIGNATURES COMPLETED	
 TGS ENGINEERS 201 W. MARION ST., STE 200 SHELBY, NC 28150 PH (704) 476-0003 CORP. LICENSE NO.: C-0275	

7/27/2022 X:\NC000\A-0009\Traffic\Signing\VA-0009CB\CADD\Signing Layout Plans\A-0009CB_Sgn_SGN_Sign04.dgn User:sme\vrn

GRAHAM COUNTY WILL BE RESPONSIBLE TO STOCKPILE AND TO REINSTALL EXISTING STREET SIGNS OR INSTALL NEW SIGNS ON NEW SUPPORTS IN THE PROJECT AREA.

**EXISTING AND PROPOSED
SIGNS**
-L- NC 143 FROM 208+00 TO 232+00

NO EXISTING SIGNS ON THIS SHEET

235

240

MATCH LINE STA 232+00 -L-
SEE SHEET SIGN-4

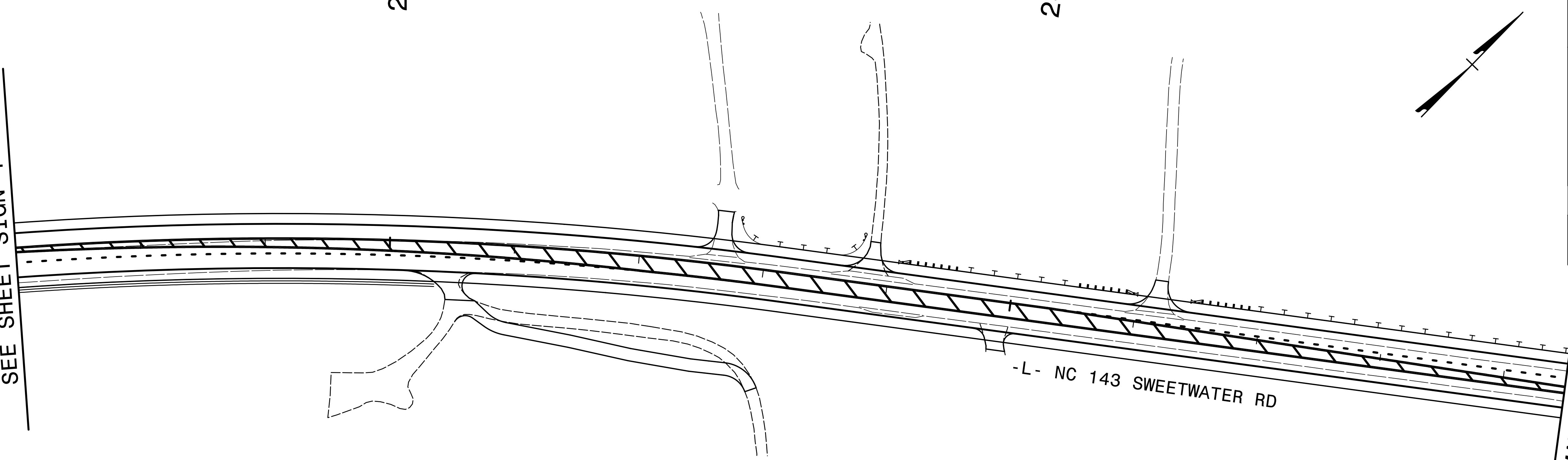

MATCH LINE
STA 244+50 -L-
SEE BELOW

TIP NO. A-0009CB	SHEET NO. SIGN-5
APPROVED:  DocuSigned by: Jimmy Terry FO99F3885E94D0	
DATE: 7/27/2022	
SEAL 	
DOCUMENT NOT CONSIDERED FINAL UNLESS ALL SIGNATURES COMPLETED	
 TGS ENGINEERS 201 W. MARION ST., STE 200 SHELBY, NC 28150 PH (704) 476-0003 CORP. LICENSE NO.: C-0275	

245

250

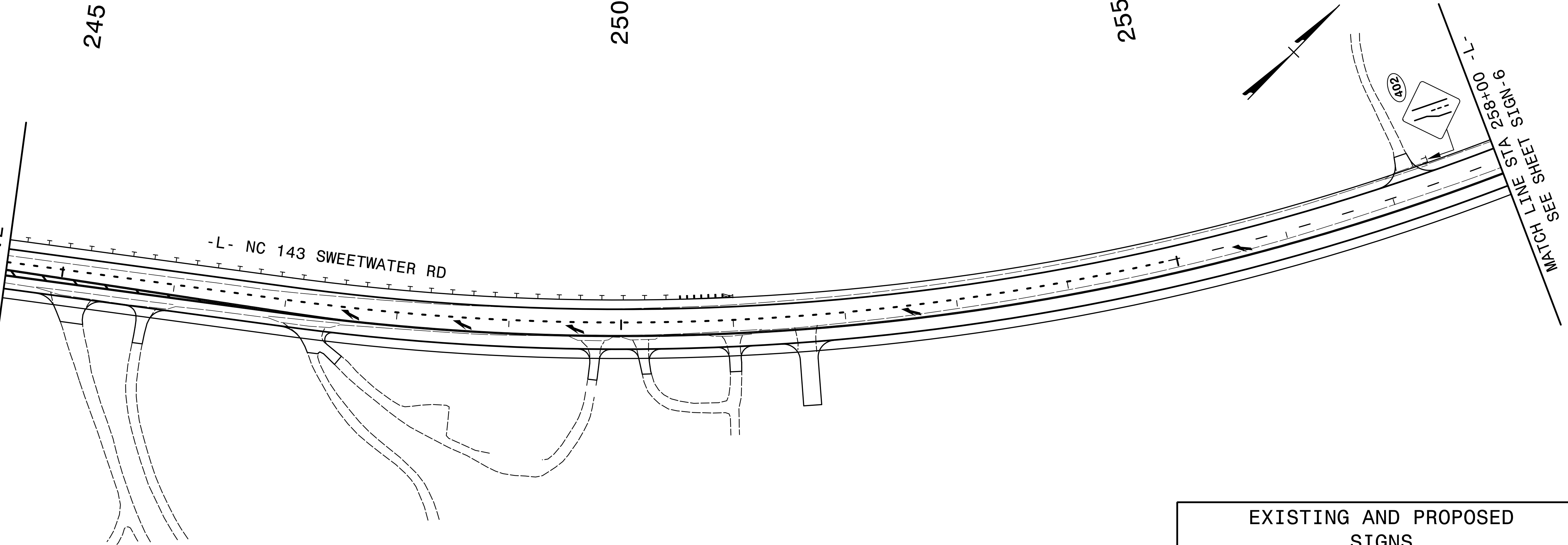

255

MATCH LINE STA 244+50 -L-
SEE ABOVE



MATCH LINE STA 258+00 -L-
SEE SHEET SIGN-6

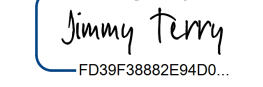
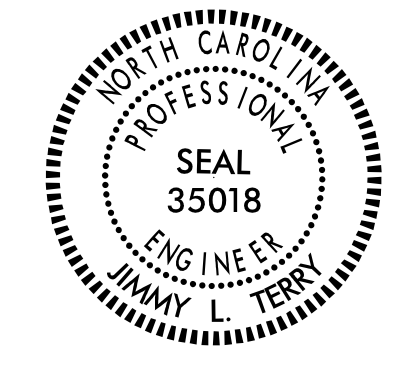

EXISTING AND PROPOSED
SIGNS
-L- NC 143 FROM 232+00 TO 258+00

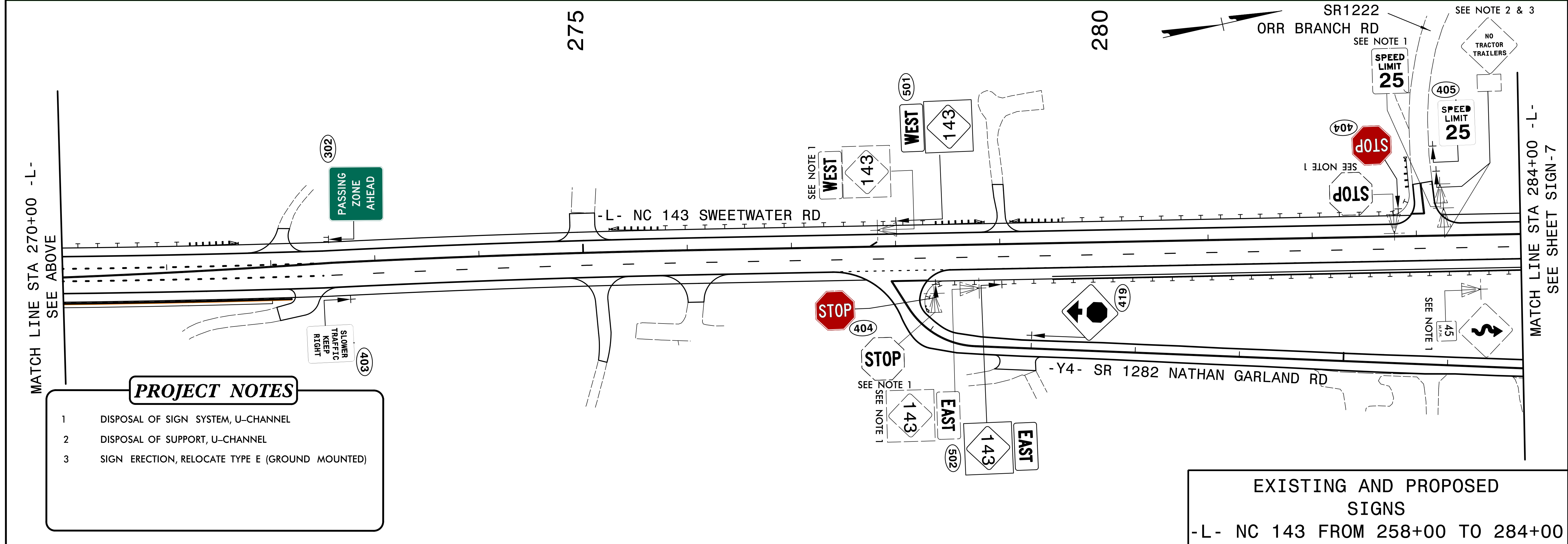
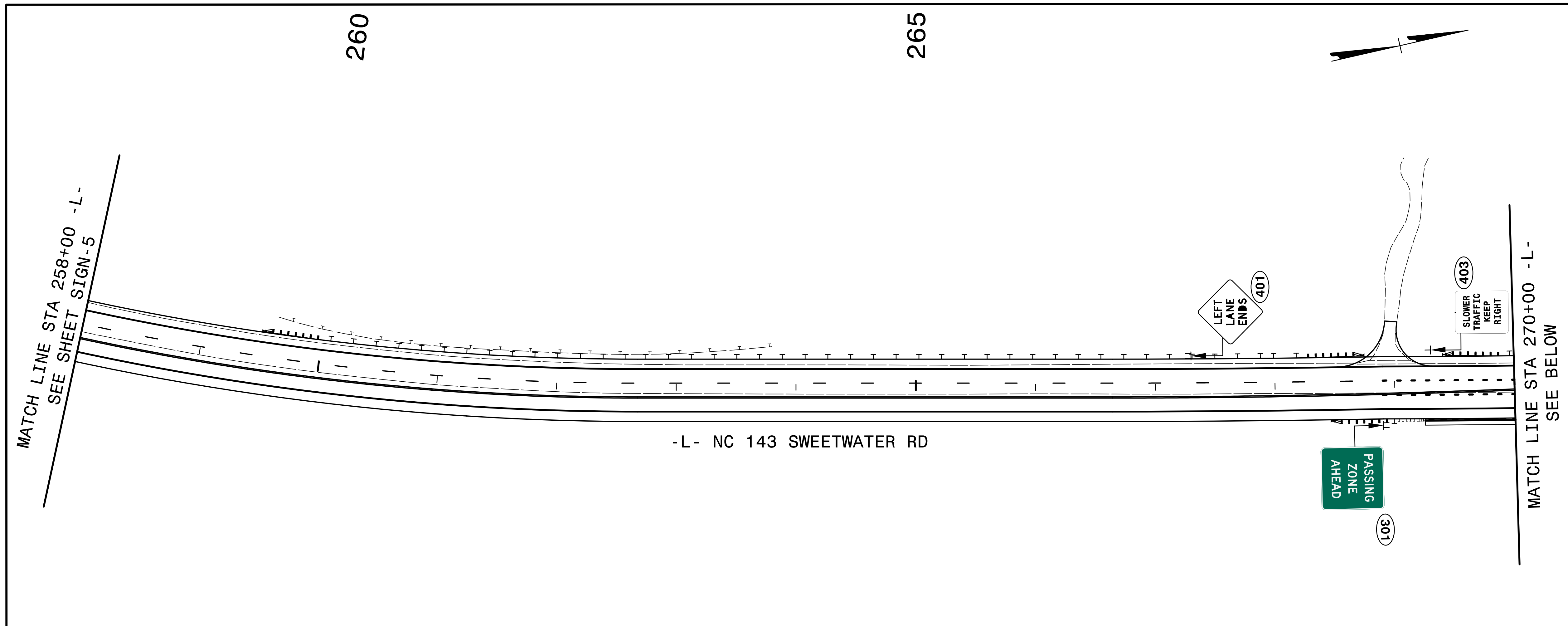
TIP NO. A-0009CB	SHEET NO. SIGN-6
APPROVED:  DocuSigned by: Jimmy Terry FD39F8882E54D0...	
DATE: 7/27/2022	
SEAL 	
DOCUMENT NOT CONSIDERED FINAL UNLESS ALL SIGNATURES COMPLETED	
 TGS ENGINEERS 201 W. MARION ST., STE 200 SHELBY, NC 28150 PH (704) 476-0003 CORP. LICENSE NO.: C-0275	



- PROJECT NOTES**
- 1 DISPOSAL OF SIGN SYSTEM, U-CHANNEL
 - 2 DISPOSAL OF SUPPORT, U-CHANNEL
 - 3 SIGN ERECTION, RELOCATE TYPE E (GROUND MOUNTED)

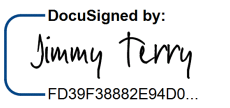

EXISTING AND PROPOSED SIGNS
 -L- NC 143 FROM 258+00 TO 284+00

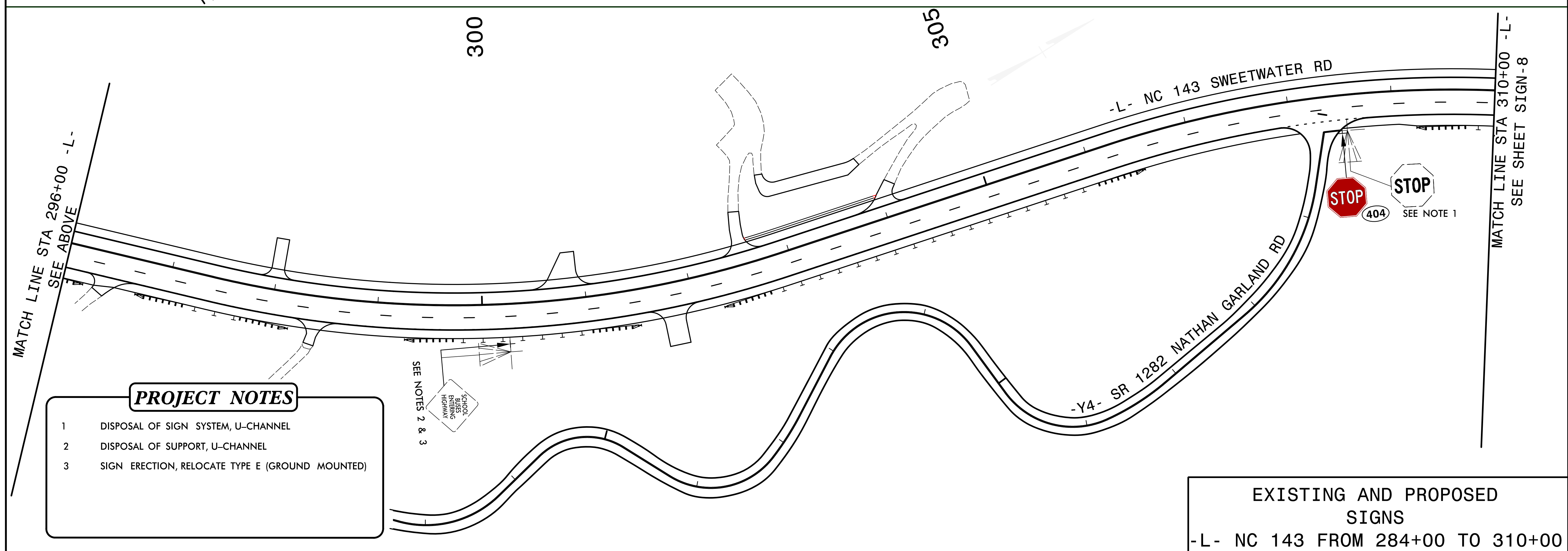
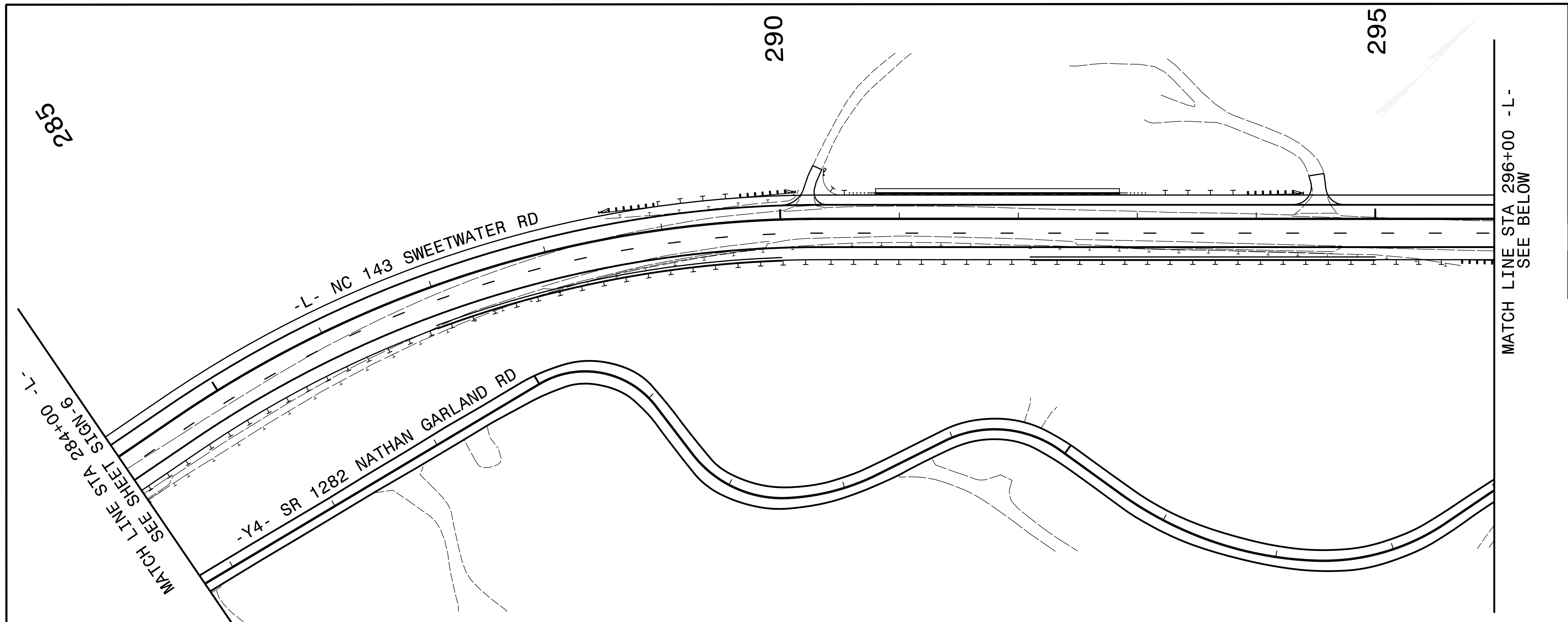
TIP NO. A-0009CB	SHEET NO. SIGN-7
APPROVED:  DocuSigned by: Jimmy Terry 7209F38802E44D0	
DATE: 7/27/2022	
SEAL 	
DOCUMENT NOT CONSIDERED FINAL UNLESS ALL SIGNATURES COMPLETED	
 TGS ENGINEERS 201 W. MARION ST., STE 200 SHELBY, NC 28150 PH (704) 476-0003 CORP. LICENSE NO.: C-0275	

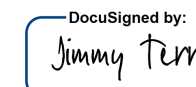

- PROJECT NOTES**
- 1 DISPOSAL OF SIGN SYSTEM, U-CHANNEL
 - 2 DISPOSAL OF SUPPORT, U-CHANNEL
 - 3 SIGN ERECTION, RELOCATE TYPE E (GROUND MOUNTED)

EXISTING AND PROPOSED
SIGNS
-L- NC 143 FROM 284+00 TO 310+00

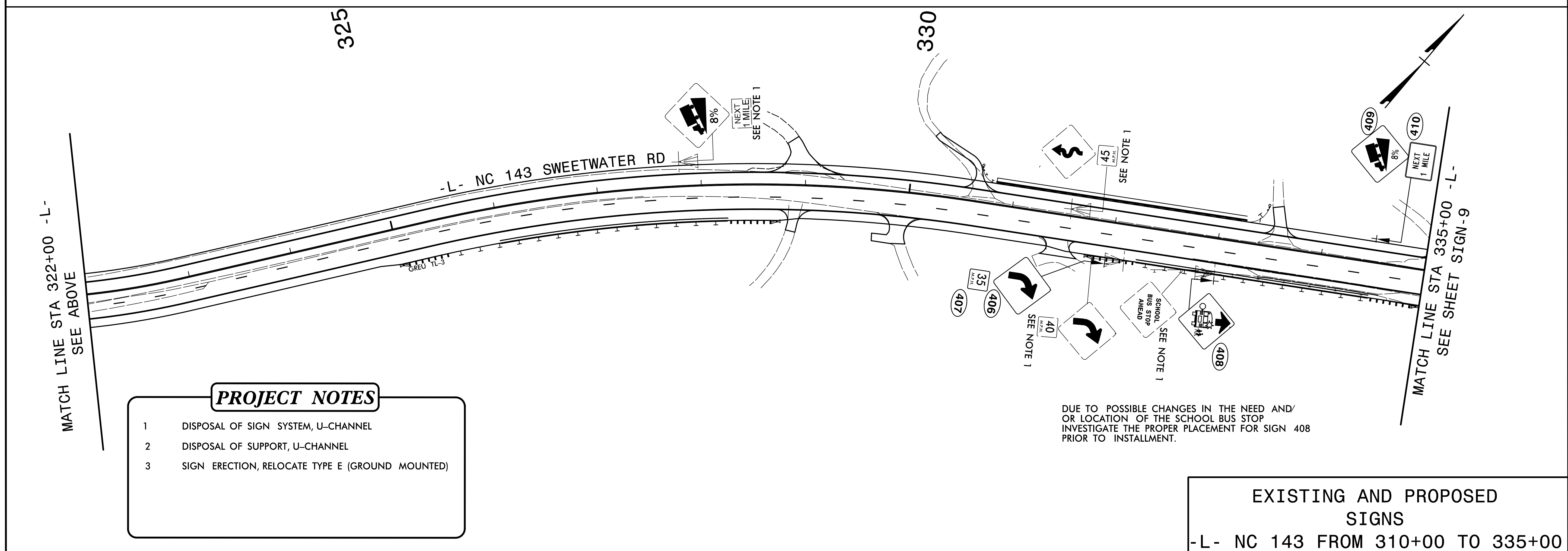
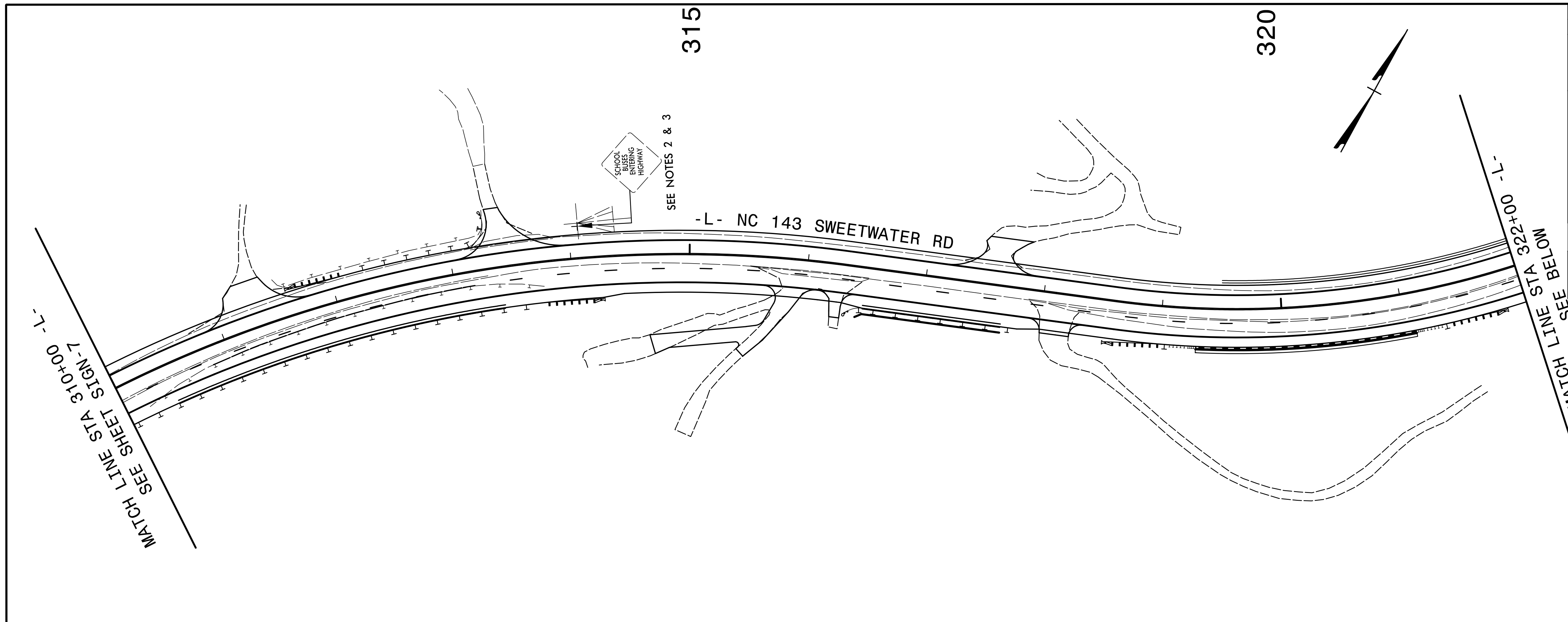

TIP NO. A-0009CB	SHEET NO. SIGN-8
APPROVED:  DATE: 7/27/2022	
SEAL 	
DOCUMENT NOT CONSIDERED FINAL UNLESS ALL SIGNATURES COMPLETED	
 TGS ENGINEERS 201 W. MARION ST., STE 200 SHELBY, NC 28150 PH: (704) 476-0003 CORP. LICENSE NO.: C-0275	



- PROJECT NOTES**
- 1 DISPOSAL OF SIGN SYSTEM, U-CHANNEL
 - 2 DISPOSAL OF SUPPORT, U-CHANNEL
 - 3 SIGN ERECTION, RELOCATE TYPE E (GROUND MOUNTED)

DUE TO POSSIBLE CHANGES IN THE NEED AND/OR LOCATION OF THE SCHOOL BUS STOP INVESTIGATE THE PROPER PLACEMENT FOR SIGN 408 PRIOR TO INSTALLMENT.

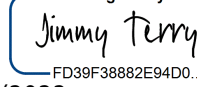
EXISTING AND PROPOSED SIGNS
 -L- NC 143 FROM 310+00 TO 335+00

TIP NO. A-0009CB	SHEET NO. SIGN-9
APPROVED:  DATE: 7/27/2022	
SEAL 	
DOCUMENT NOT CONSIDERED FINAL UNLESS ALL SIGNATURES COMPLETED	
TGS ENGINEERS 201 W. MARION ST., STE 200 SHELBY, NC 28150 PH (704) 476-0003 CORP. LICENSE NO.: C-0275	

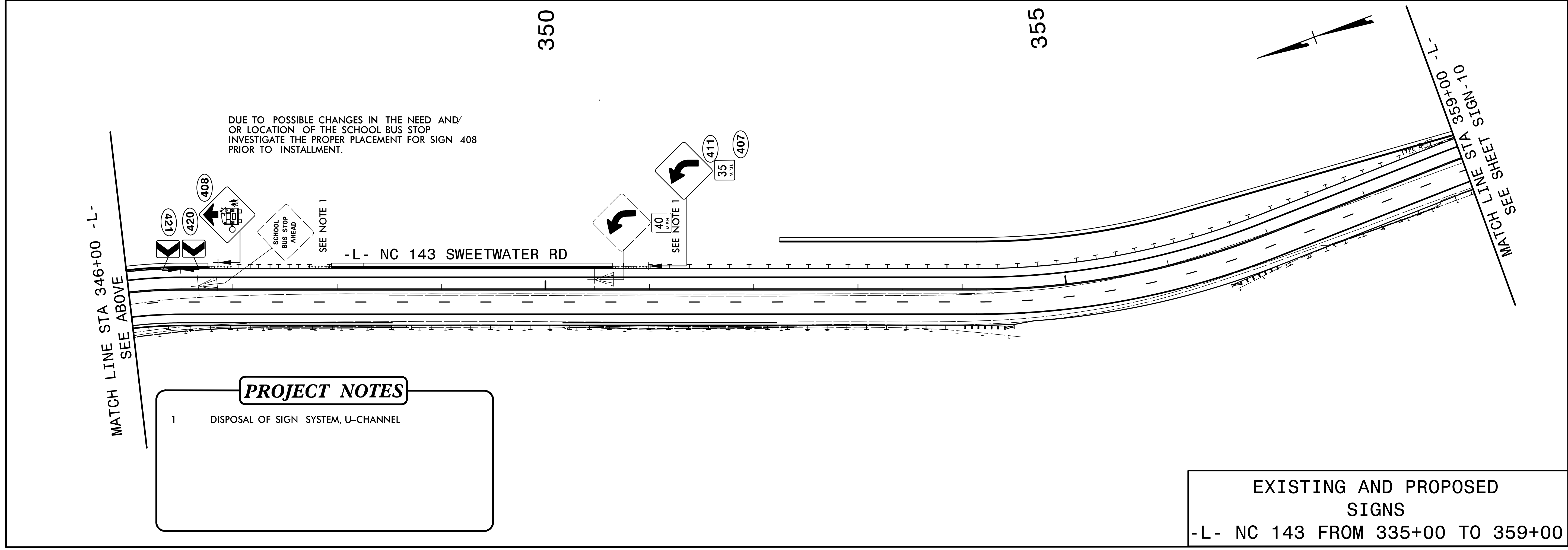
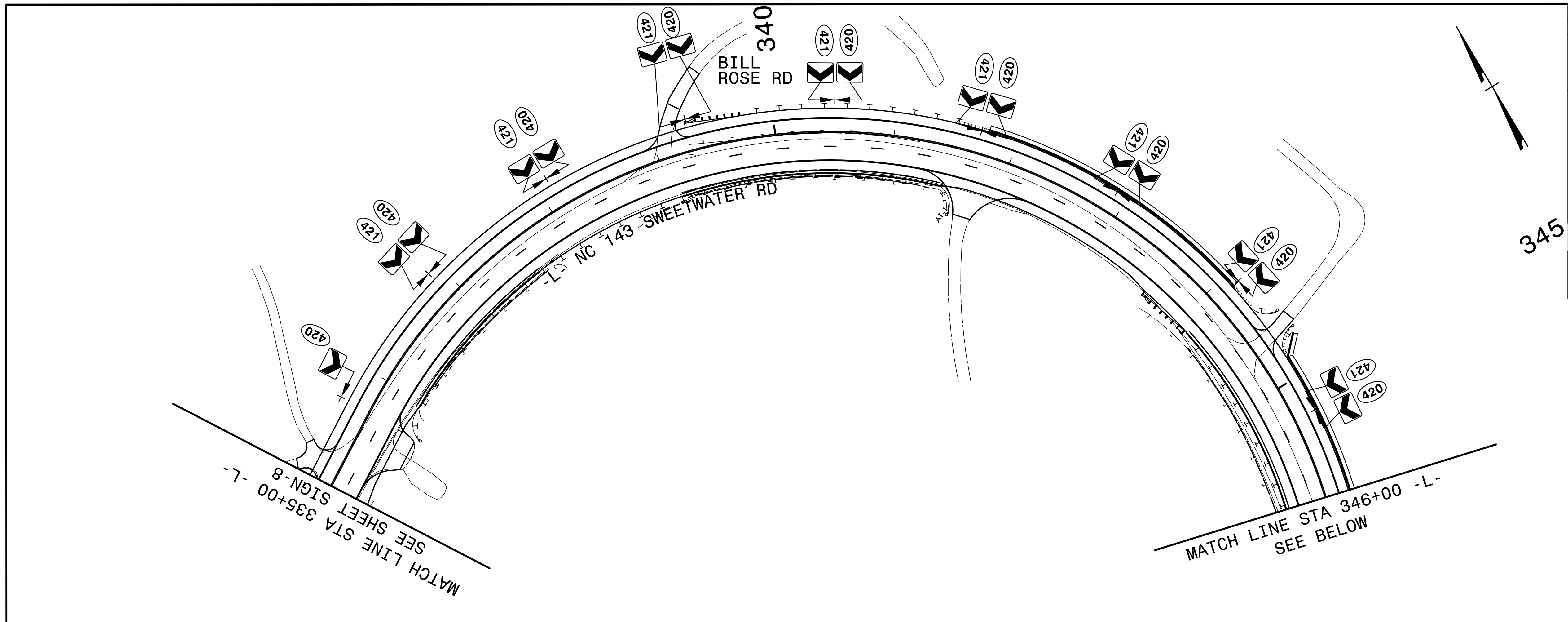



DUE TO POSSIBLE CHANGES IN THE NEED AND/OR LOCATION OF THE SCHOOL BUS STOP INVESTIGATE THE PROPER PLACEMENT FOR SIGN 408 PRIOR TO INSTALLMENT.

PROJECT NOTES

- 1 DISPOSAL OF SIGN SYSTEM, U-CHANNEL

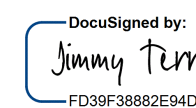
EXISTING AND PROPOSED
SIGNS
-L- NC 143 FROM 335+00 TO 359+00

TIP NO. A-0009CB	SHEET NO. SIGN-10
APPROVED:  DATE: 7/27/2022	
SEAL 	
DOCUMENT NOT CONSIDERED FINAL UNLESS ALL SIGNATURES COMPLETED	
 TGS ENGINEERS 201 W. MARION ST., STE 200 SHELBY, NC 28150 PH (704) 476-0003 CORP. LICENSE NO.: C-0275	

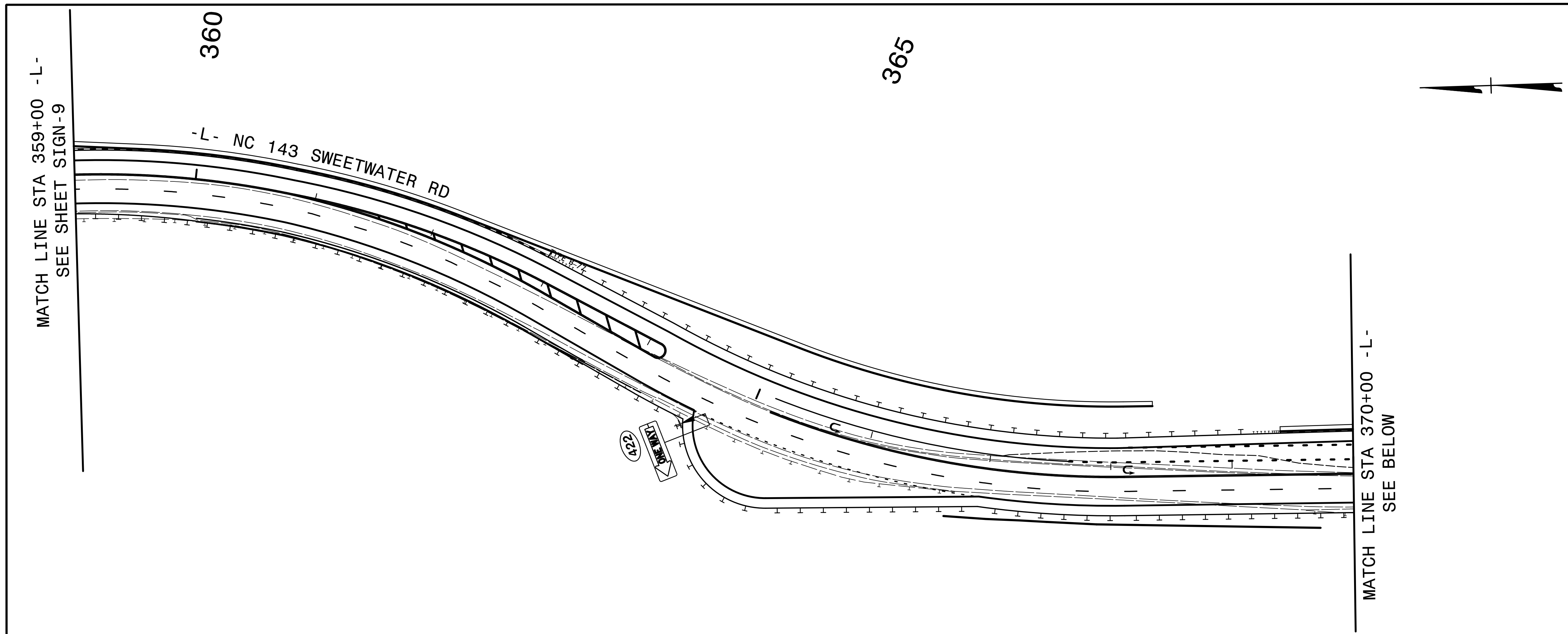

- PROJECT NOTES**
- DISPOSAL OF SIGN SYSTEM, U-CHANNEL
 - DISPOSAL OF SUPPORT, U-CHANNEL
 - SIGN ERECTION, RELOCATE TYPE D (GROUND MOUNTED)

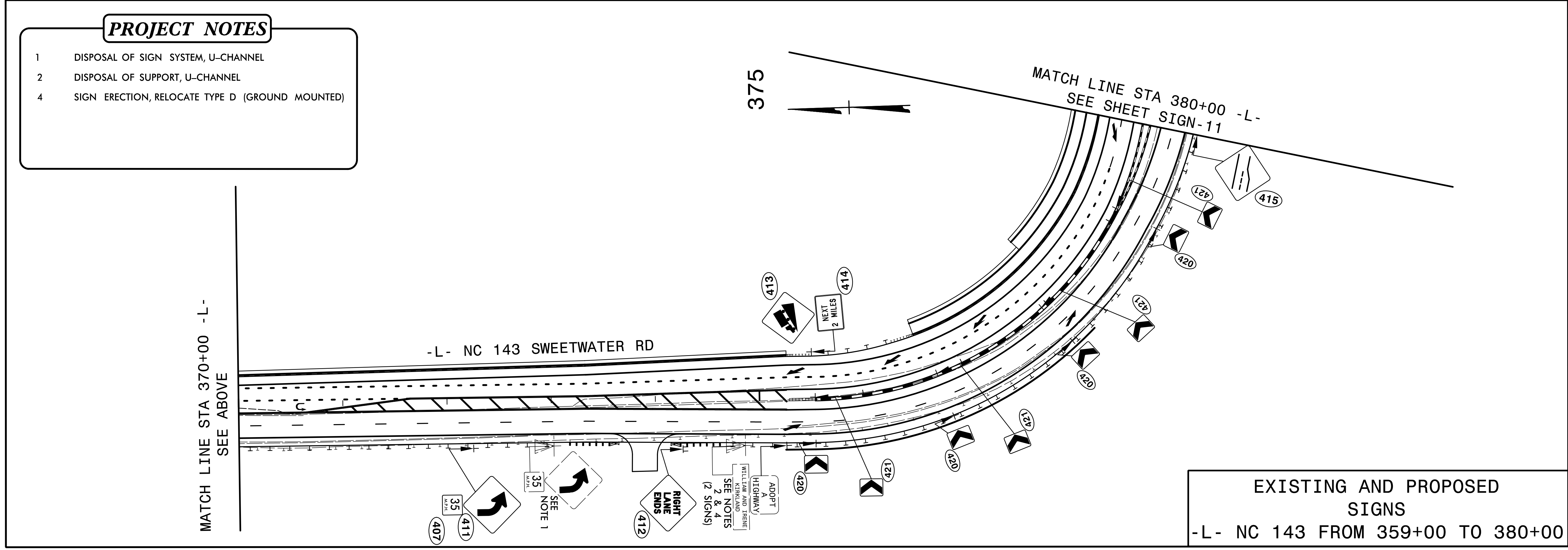

EXISTING AND PROPOSED SIGNS
 -L- NC 143 FROM 359+00 TO 380+00

TIP NO. A-0009CB	SHEET NO. SIGN-11
APPROVED: <i>Jimmy Terry</i> DATE: 7/27/2022	
SEAL 	
DOCUMENT NOT CONSIDERED FINAL UNLESS ALL SIGNATURES COMPLETED	
TGS ENGINEERS 201 W. MARION ST., STE 200 SHELBY, NC 28150 PH (704) 476-0003 CORP. LICENSE NO.: C-0275	

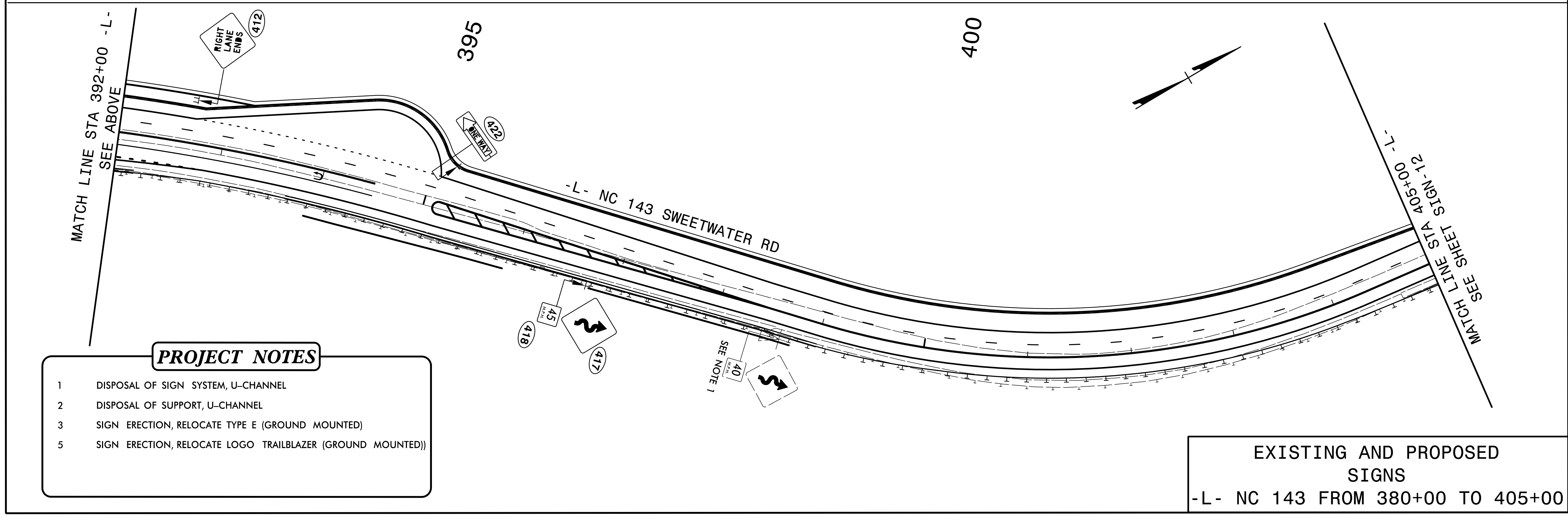
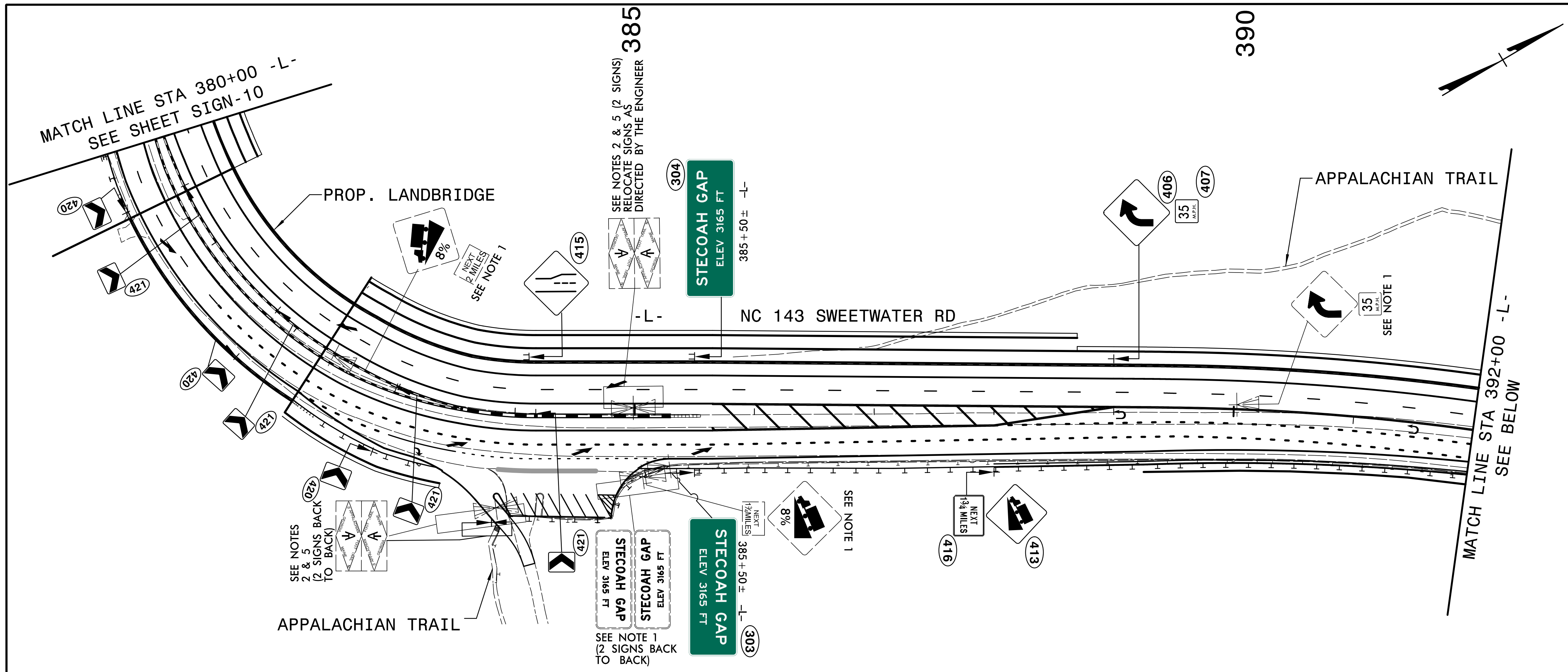



- PROJECT NOTES**
- 1 DISPOSAL OF SIGN SYSTEM, U-CHANNEL
 - 2 DISPOSAL OF SUPPORT, U-CHANNEL
 - 3 SIGN ERECTION, RELOCATE TYPE E (GROUND MOUNTED)
 - 5 SIGN ERECTION, RELOCATE LOGO TRAILBLAZER (GROUND MOUNTED)

EXISTING AND PROPOSED SIGNS
-L- NC 143 FROM 380+00 TO 405+00

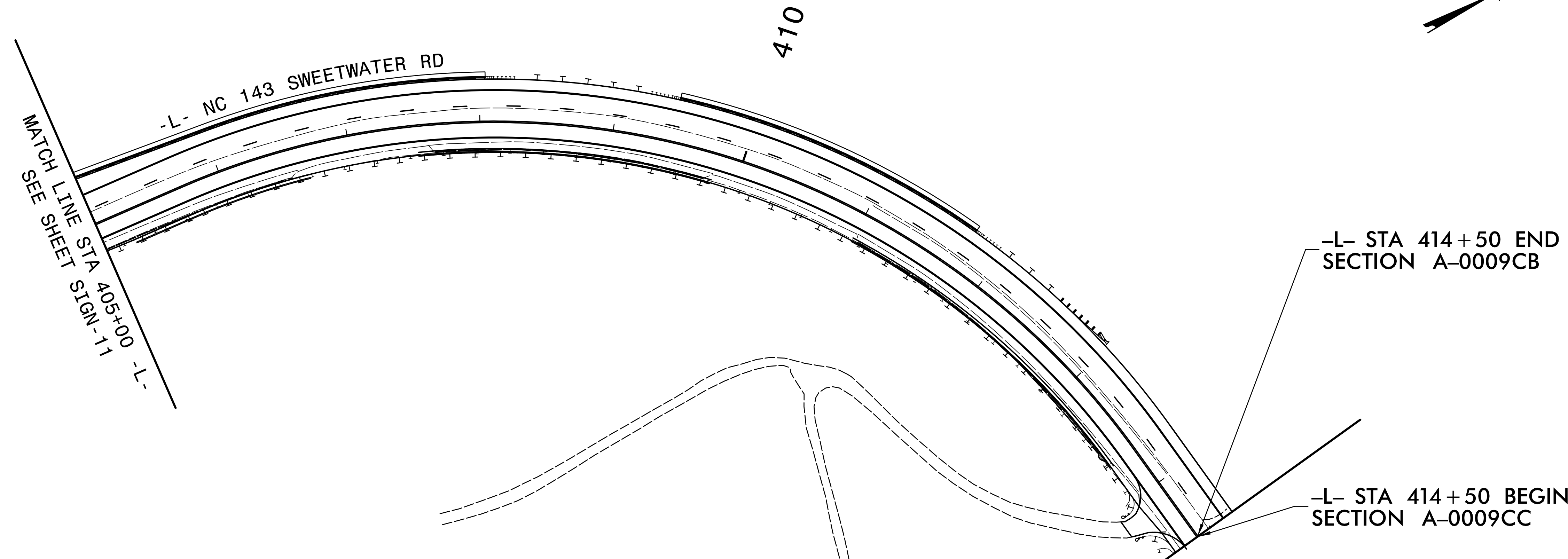
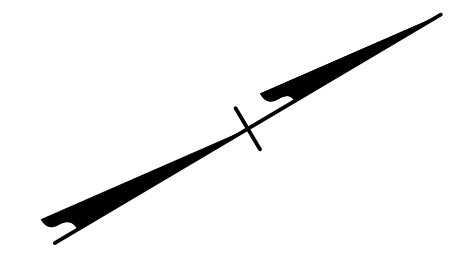
NO PROPOSED OR EXISTING SIGNS ON THIS SHEET

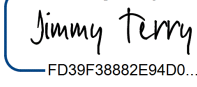

TIP NO. A-0009CB	SHEET NO. SIGN-12
APPROVED:  DocuSigned by: Jimmy Terry FD39F3882E34D0...	
DATE: 7/27/2022	
SEAL 	
DOCUMENT NOT CONSIDERED FINAL UNLESS ALL SIGNATURES COMPLETED	
 TGS ENGINEERS 201 W. MARION ST., STE 200 SHELBY, NC 28150 PH: (704) 476-0003 CORP. LICENSE NO.: C-0275	

EXISTING AND PROPOSED
SIGNS
-L- NC 143 FROM 405+00 TO 414+50