

**This electronic collection of documents is provided
for the convenience of the user
and is Not a Certified Document –**

**The documents contained herein were originally issued
and sealed by the individuals whose names and license
numbers appear on each page, on the dates appearing
with their signature on that page.**

**This file or an individual page
shall not be considered a certified document.**

T.I.P.: A-0009CB

**STATE OF NORTH CAROLINA
DEPARTMENT OF TRANSPORTATION**

**PAVEMENT MARKING PLAN
GRAHAM COUNTY**

**LOCATION: NC 143 FROM SR 1223 (BEECH CREEK RD) TO
0.5 MI NORTH OF APPALACHIAN TRAIL**

<small>TIP NO.</small> A - 0009CB	<small>SHEET NO.</small> PMP - 1
<small>APPROVED:</small> <small>FO39F3882E4D0</small>	
<small>DATE:</small> 7/27/2022	
<small>DOCUMENT NOT CONSIDERED FINAL UNLESS ALL SIGNATURES COMPLETED</small>	

INDEX

<small>SHEET NO.</small>	<small>DESCRIPTION</small>
PMP-1	PAVEMENT MARKING PLAN TITLE, INDEX OF SHEETS, LIST OF APPLICABLE ROADWAY STANDARD DRAWINGS, GENERAL NOTES AND FINAL PAVEMENT MARKING SCHEDULE
PMP-1A	REVISED PAVEMENT MARKING RDY STD 1205.04 SHEET 2 OF 2
PMP-2 THRU PMP-10	PAVEMENT MARKING DETAIL

GENERAL NOTES

THE FOLLOWING GENERAL NOTES APPLY AT ALL TIMES FOR THE DURATION OF THE CONSTRUCTION PROJECT, EXCEPT WHEN OTHERWISE NOTED IN THE PLAN, OR DIRECTED BY THE ENGINEER.

A) INSTALL PAVEMENT MARKINGS AND PAVEMENT MARKERS ON THE FINAL SURFACE AS FOLLOWS:

<small>ROAD NAME</small>	<small>MARKING</small>	<small>MARKER</small>
NC 143 -L-	THERMOPLASTIC	SNOWPLOWABLE
NATHEN GARLAND RD -Y4-	THERMOPLASTIC	NONE
ORR BRANCH RD	THERMOPLASTIC	NONE

B) TIE PROPOSED PAVEMENT MARKING LINES TO EXISTING PAVEMENT MARKING LINES.

C) REMOVE/REPLACE ANY CONFLICTING/DAMAGED PAVEMENT MARKINGS AND MARKERS.

D) STOP BAR LOCATION AT NON-SIGNALIZED INTERSECTIONS MAY BE ADJUSTED AS DIRECTED BY THE ENGINEER.

E) UNLESS OTHERWISE SPECIFIED, HEATED-IN-PLACE THERMOPLASTIC MAY BE USED IN LIEU OF EXTRUDED THERMOPLASTIC FOR STOP BARS, SYMBOLS, CHARACTERS AND DIAGONALS. IF HEATED-IN-PLACE IS USED, IT SHALL BE PAID FOR USING THE EXTRUDED THERMOPLASTIC PAY ITEM.

**FINAL PAVEMENT MARKING
SCHEDULE**

<small>SYMBOL</small>	<small>DESCRIPTION</small>
PAVEMENT MARKINGS	
THERMOPLASTIC (4", 90 MILS)	
T1	(4") WHITE EDGELINE
T2	(4") WHITE SOLID LANE LINE
T3	(4") 10 FT. WHITE SKIP
T4	(4") 3 FT. - 9 FT./SP WHITE MINISKIP
T5	(4") 2 FT. - 6 FT./SP WHITE MINISKIP
T10	(4") YELLOW SINGLE CENTER
T13	(4") YELLOW DOUBLE CENTER
THERMOPLASTIC (12", 90 MILS)	
T52	(12") YELLOW DIAGONAL
THERMOPLASTIC GENERIC PAVEMENT MARKING ITEM (1205)	
T61	WHITE STOPBAR (24", 90 MIL)
THERMOPLASTIC PAVEMENT MARKING SYMBOLS (90 MILS)	
T71	RIGHT TURN ARROW
T77	U-TURN ARROW
T79	MERGE ARROW

ROADWAY STANDARD DRAWING

THE FOLLOWING ROADWAY STANDARDS AS APPEAR IN "ROADWAY STANDARD DRAWINGS" - PROJECT SERVICES UNIT - N.C. DEPARTMENT OF TRANSPORTATION - RALEIGH, N.C., DATED JANUARY 2018 ARE APPLICABLE TO THIS PROJECT AND BY REFERENCE HEREBY ARE CONSIDERED A PART OF THESE PLANS:

<small>STD. NO.</small>	<small>TITLE</small>
1205.01	PAVEMENT MARKINGS - LINE TYPES AND OFFSETS
1205.02	PAVEMENT MARKINGS - TWO-LANE AND MULTILANE ROADWAYS
1205.04	PAVEMENT MARKINGS - INTERSECTIONS
1205.05	PAVEMENT MARKINGS - TURN LANES
1205.09	PAVEMENT MARKINGS - PAINTED ISLANDS
1205.13	PAVEMENT MARKINGS - LANE REDUCTIONS
1250.01	RAISED PAVEMENT MARKERS - INSTALLATION SPACING
1251.01	RAISED PAVEMENT MARKERS - PERMANENT AND TEMPORARY
1253.01	RAISED PAVEMENT MARKERS - SNOWPLOWABLE
1261.01	GUARDRAIL AND BARRIER DELINEATORS - INSTALLATION SPACING
1261.02	GUARDRAIL AND BARRIER DELINEATORS - TYPES AND MOUNTING
1262.01	GUARDRAIL END DELINEATION

PLAN SUBMITTED TO: NCDOT DIVISION 14

WANDA H. AUSTIN, PE DIVISION ENGINEER

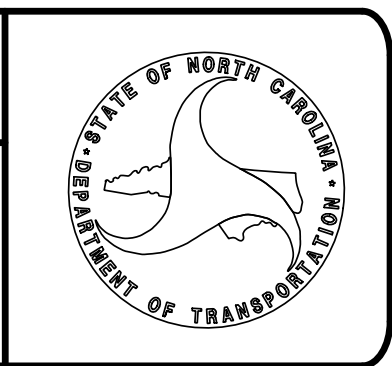

PLAN PREPARED BY: TGS ENGINEERS

JIMMY TERRY, PE PROJECT ENGINEER	 TGS ENGINEERS 201 W. MARION ST SHELBY, NC 28150 PH (704) 476-0003 CORP. LICENSE NO.: C-0275
SANDRA MELVIN DESIGN TECHNICIAN	

TIP NO.	SHEET NO.
DocuSigned by:	
<i>Matthew V. Springer</i>	
APPROVED:	8/13/2019
DATE:	6/26/2019 10:58:44 AM
SEAL	

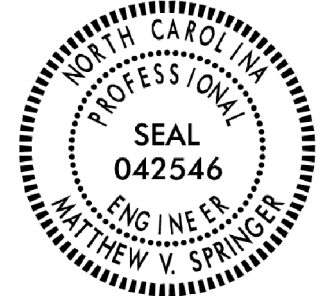
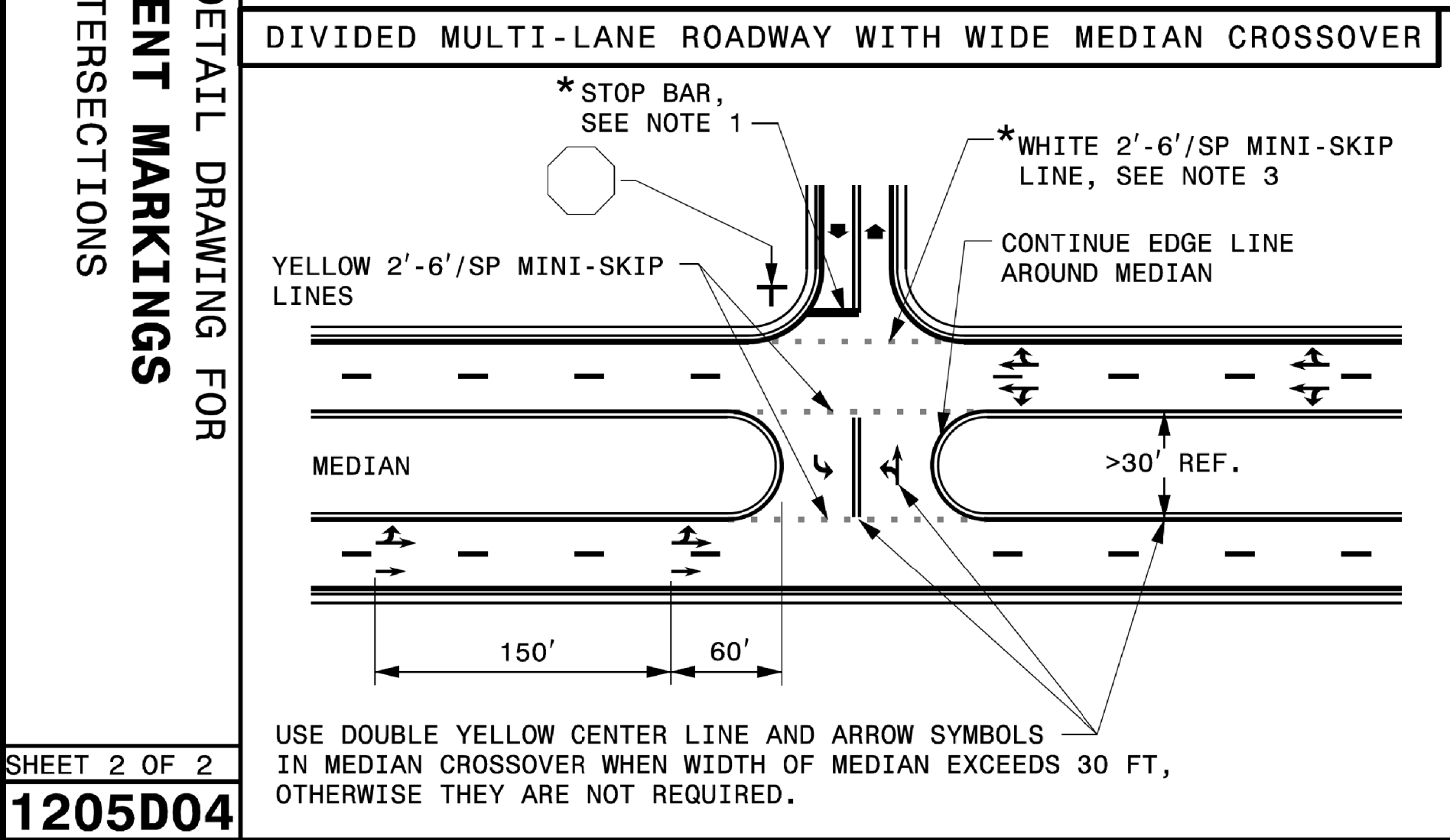
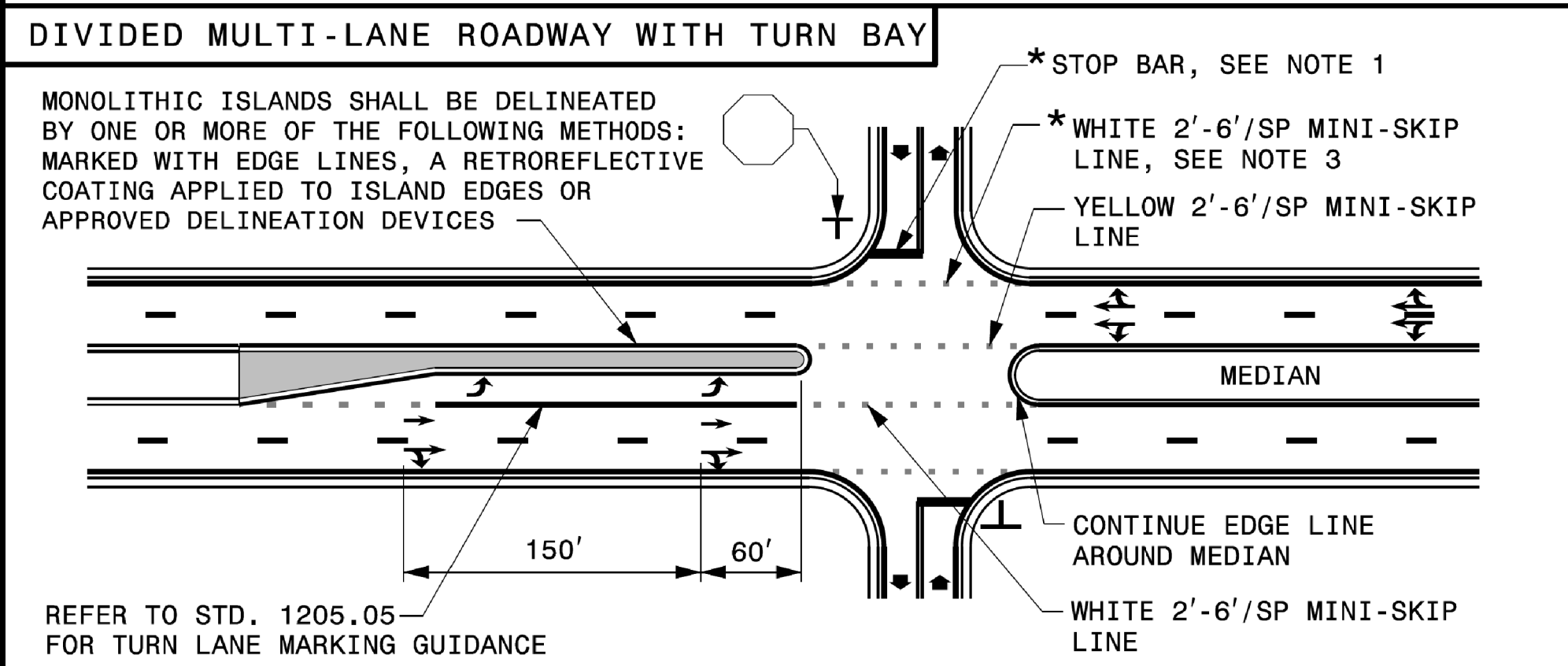
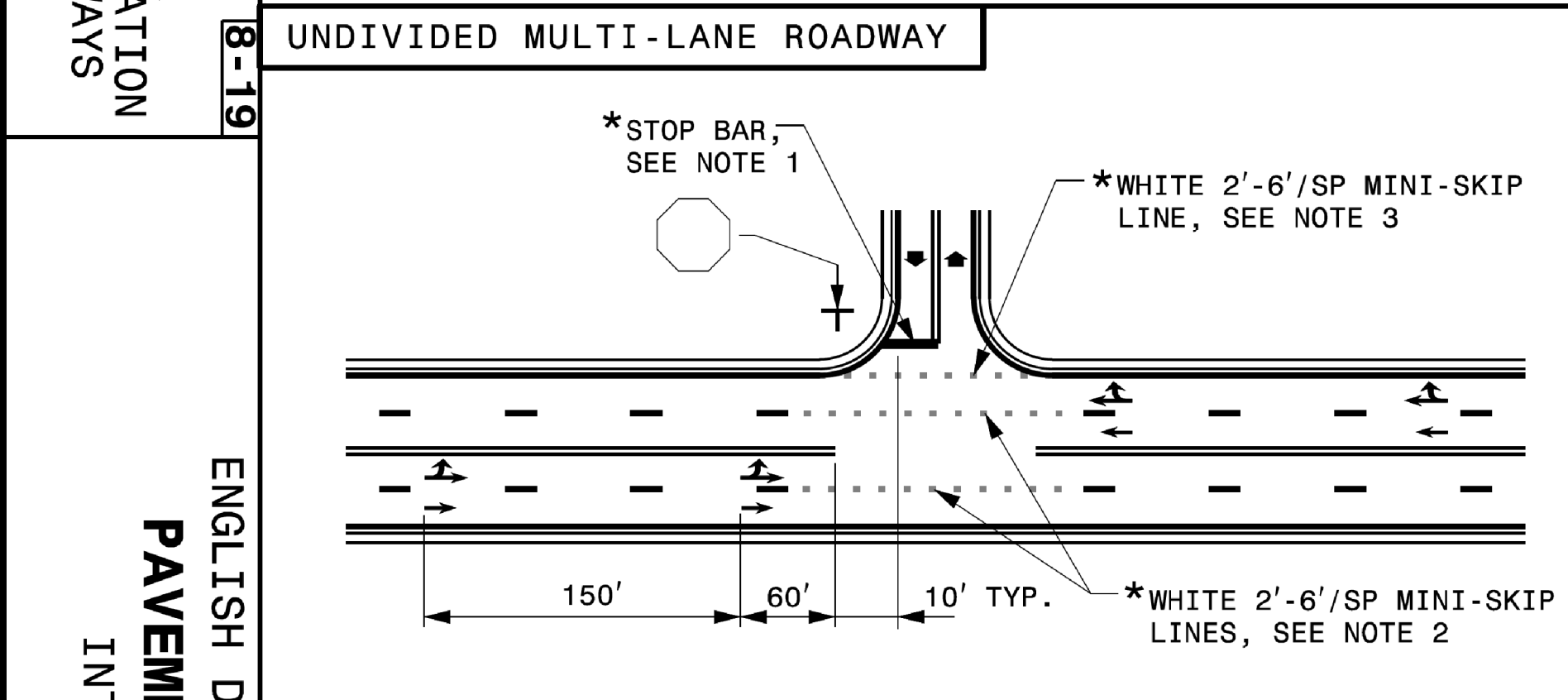
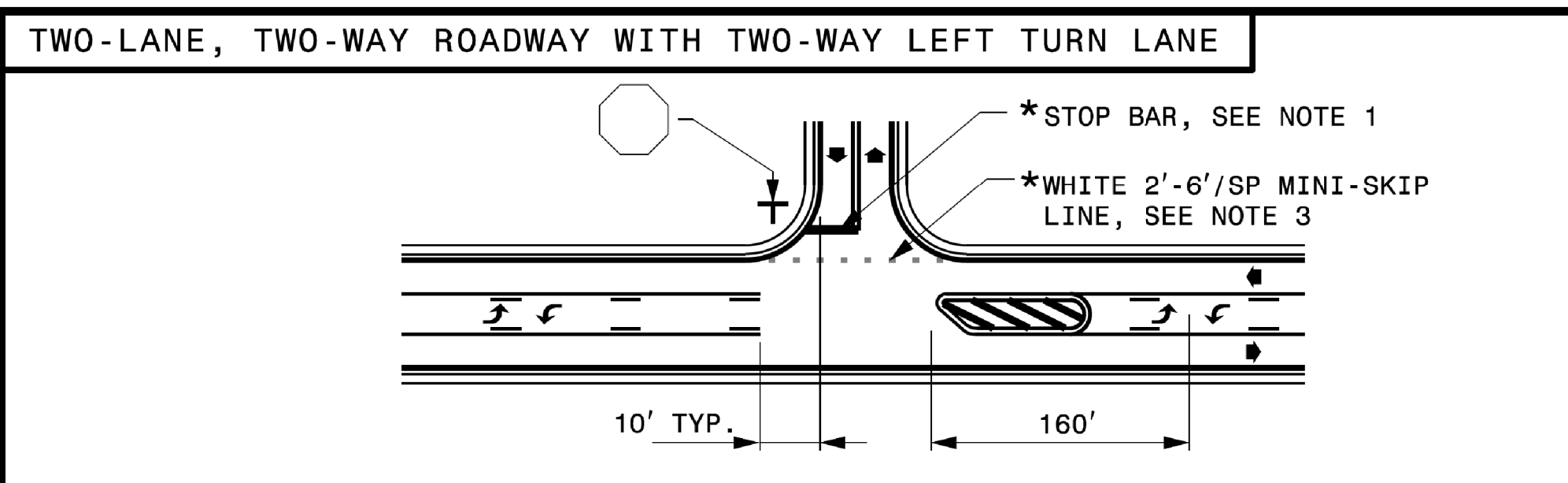
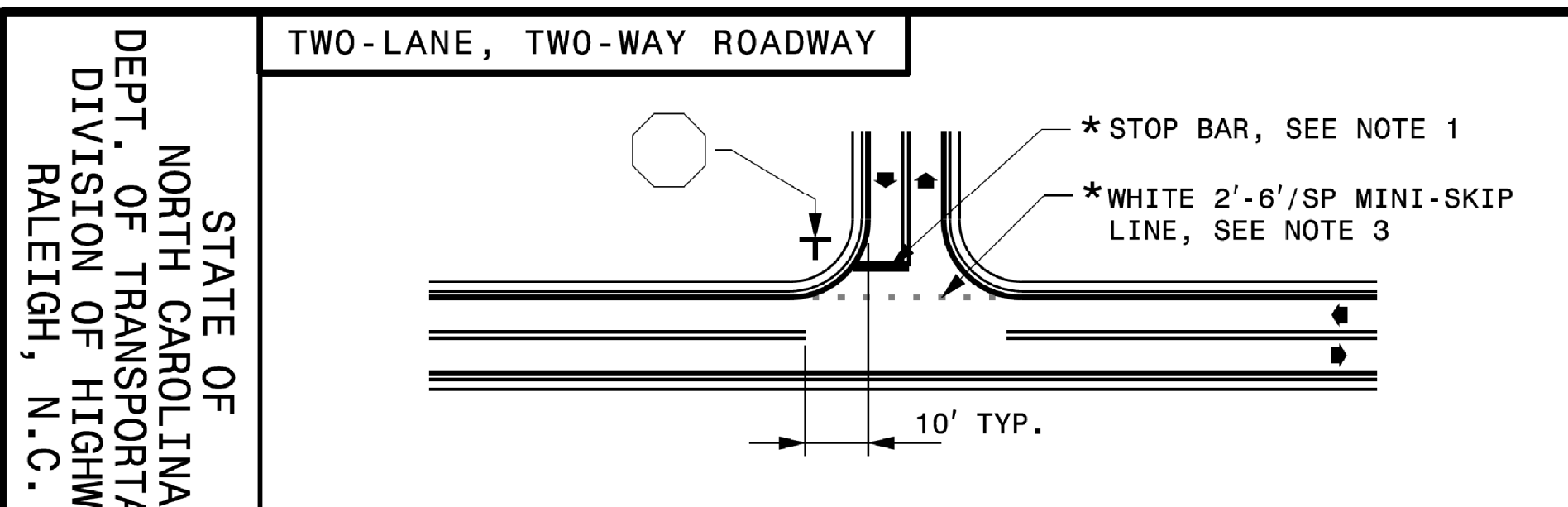
GENERAL NOTES:

- 1- PLACEMENT OF STOP BARS AT NON-SIGNALIZED INTERSECTIONS IS OPTIONAL AND USED WHERE IT IS IMPORTANT TO INDICATE THE POINT WHICH VEHICLES ARE REQUIRED TO STOP. PLACE STOP BARS NO LESS THAN 4 FEET AND NO MORE THAN 30 FEET FROM THE NEAREST EDGE OF THE INTERSECTING ROADWAY. USE 10 FEET AS THE TYPICAL SETBACK DISTANCE OR AS DIRECTED BY THE ENGINEER.
- 2- MINI-SKIP LANE LINE EXTENSIONS SHOULD BE USED AT INTERSECTIONS THAT HAVE REDUCED VISIBILITY CONDITIONS SUCH AS OFFSET, SKEWED, OR CURVED ROADWAYS.
- 3- MINI-SKIP EDGE LINE EXTENSIONS MAY BE PLACED THROUGH INTERSECTIONS AND MAJOR DRIVEWAYS.
- 4- REFER TO ROADWAY STANDARD DRAWINGS 1205.01, 1205.02, 1205.05, 1205.08 AND 1205.09 FOR ADDITIONAL PAVEMENT MARKING GUIDANCE.

LEGEND	
	STOP SIGN
	STATIONARY SIGN
	DIRECTION OF TRAFFIC FLOW
	PAVEMENT MARKING SYMBOLS
*	OPTIONAL

SHEET 2 OF 2
1205D04

SHEET 2 OF 2
1205D04

REVISED PAVEMENT MARKING ROADWAY STANDARD DRAWING

STATE OF NORTH CAROLINA
DEPT. OF TRANSPORTATION
DIVISION OF HIGHWAYS
RALEIGH, N.C.



ENGLISH DETAIL DRAWING FOR
PAVEMENT MARKINGS
INTERSECTIONS

STATE OF NORTH CAROLINA
DEPT. OF TRANSPORTATION
DIVISION OF HIGHWAYS
RALEIGH, N.C.

ENGLISH DETAIL DRAWING FOR
PAVEMENT MARKINGS
INTERSECTIONS

5/23/2022
S:\1205D04\1205D04-0009CB\A-0009CB_Sgn_PMP_01A(12050402_08-13-19_Signed).dgn
User:smelvin

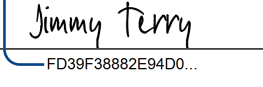
UK/3/18
S:\S&D\Standards Group\Standards and Drawings\Drawings\2018 Standard Dwgs\Division 12 Final\12050402_08-13-19.dgn
User:ststokes

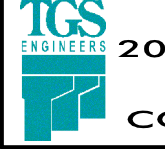
TIP NO. A-0009CB	SHEET NO. PMP-2
APPROVED:  F039F3882E94D0	
DATE: 7/27/2022	
SEAL	
	
DOCUMENT NOT CONSIDERED FINAL UNLESS ALL SIGNATURES COMPLETED	
 TGS ENGINEERS 201 W. MARION ST., STE 200 SHELBY, NC 28150 PH: (704) 476-0003 CORP. LICENSE NO.: C-0275	

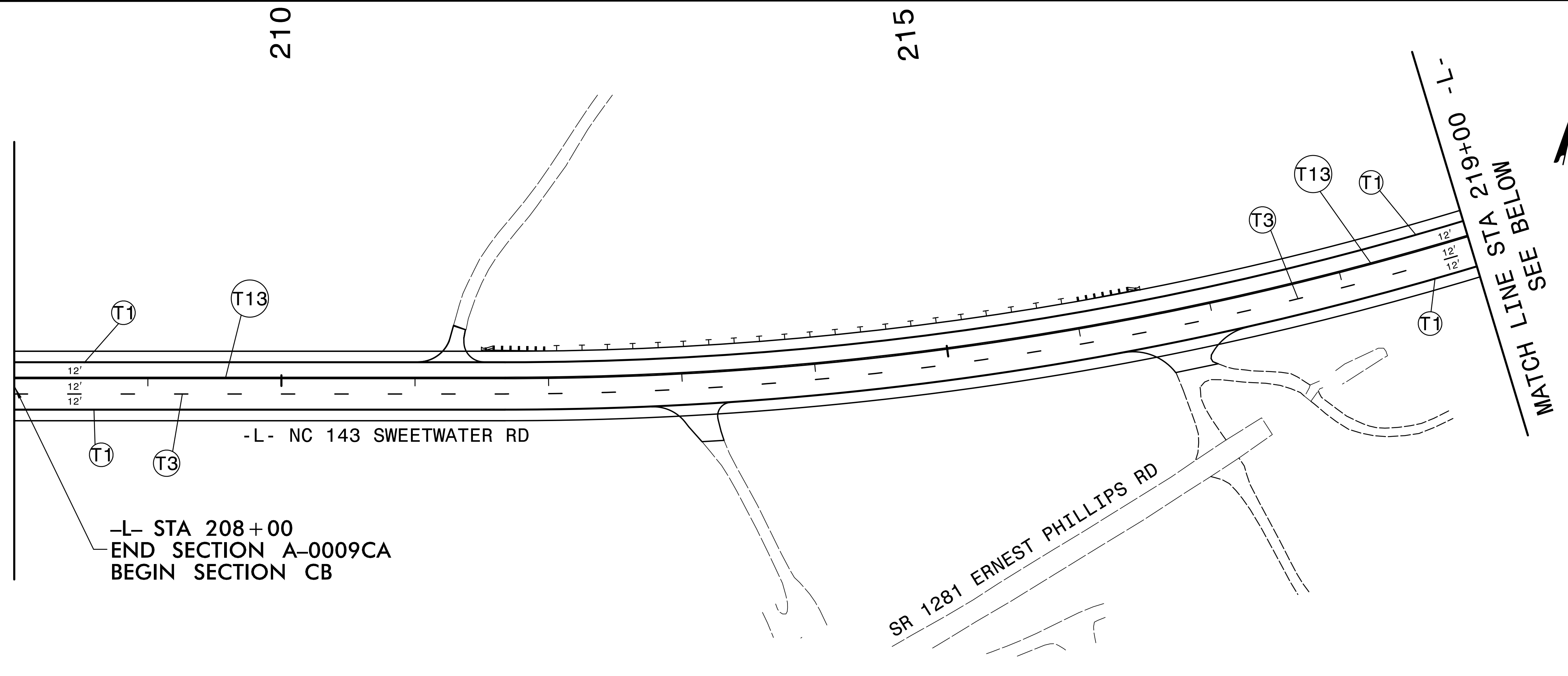

PAVEMENT MARKING SYMBOLS

T79

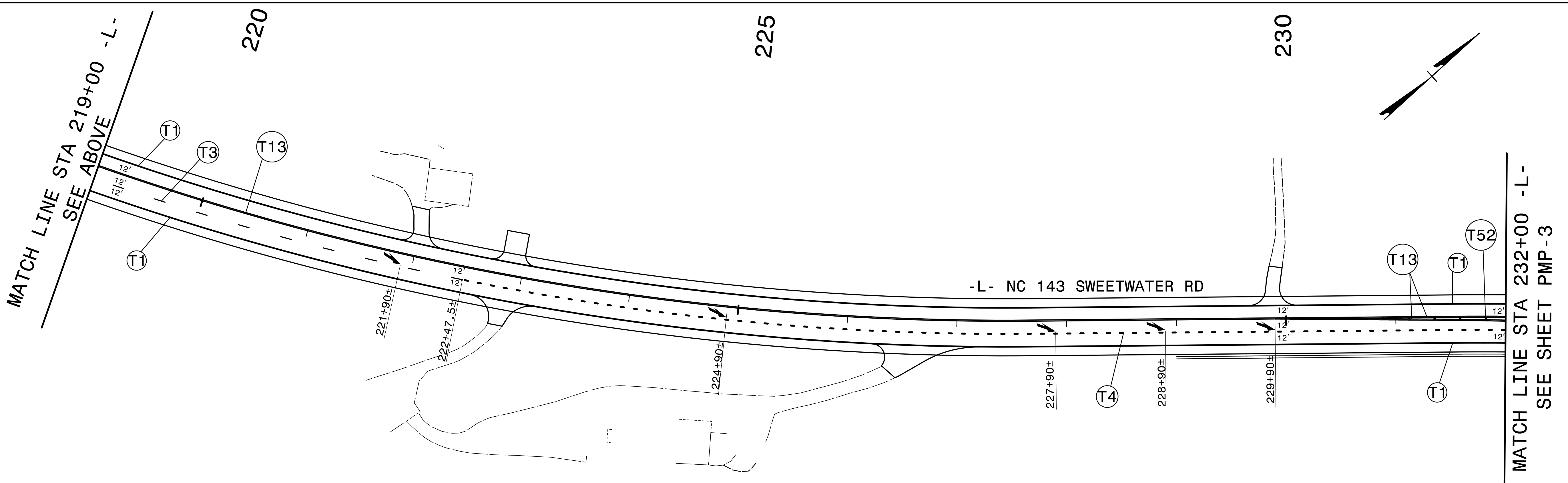

NOTES

SEE SHEET PMP-1 FOR FINAL PAVEMENT MARKING SCHEDULE.
 ENGINEER TO APPROVE LOCATIONS OF ALL UNSIGNALIZED STOP BARS.
 UNLESS OTHERWISE NOTED PLACE PAVEMENT MARKING SYMBOLS AS DIRECTED BY THE ENGINEER IN ACCORDANCE TO NCDOT STANDARDS.
 PLACE PAVEMENT MARKERS AS DIRECTED BY THE ENGINEER IN ACCORDANCE WITH NCDOT RDY STD DRAWING 1250.01

PAVEMENT MARKING DETAIL

5/23/2022
 X:\NC000\A-0009CB\Traffic\Pavement Markings\A-0009CB\A-0009CB_Sgn_PMP_02.dgn
 User:smelvin

TIP NO. A-0009CB	SHEET NO. PMP-3
APPROVED: <i>Jimmy Terry</i> FDSP#388026400	
DATE: 7/27/2022	
SEAL	
DOCUMENT NOT CONSIDERED FINAL UNLESS ALL SIGNATURES COMPLETED	
TGS ENGINEERS 201 W. MARION ST., STE 200 SHELBY, NC 28150 PH: (704) 476-0003 CORP. LICENSE NO.: C-0275	

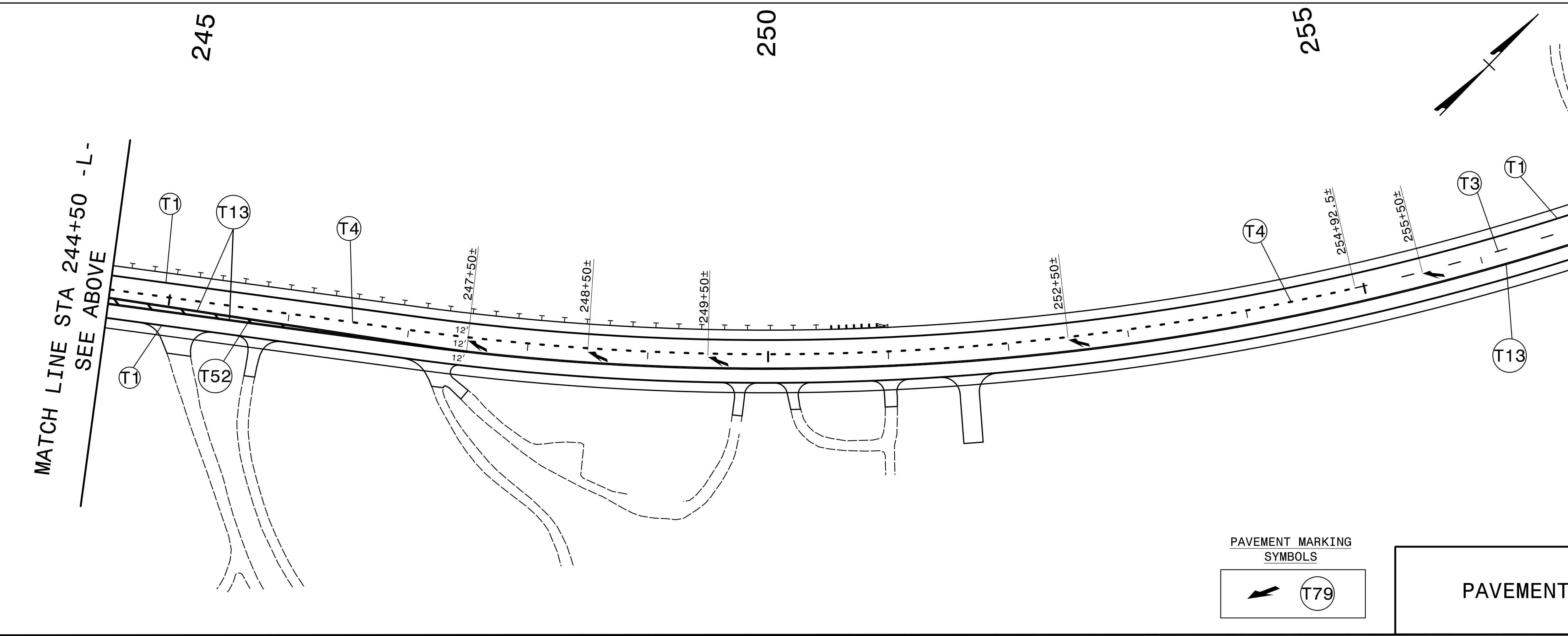
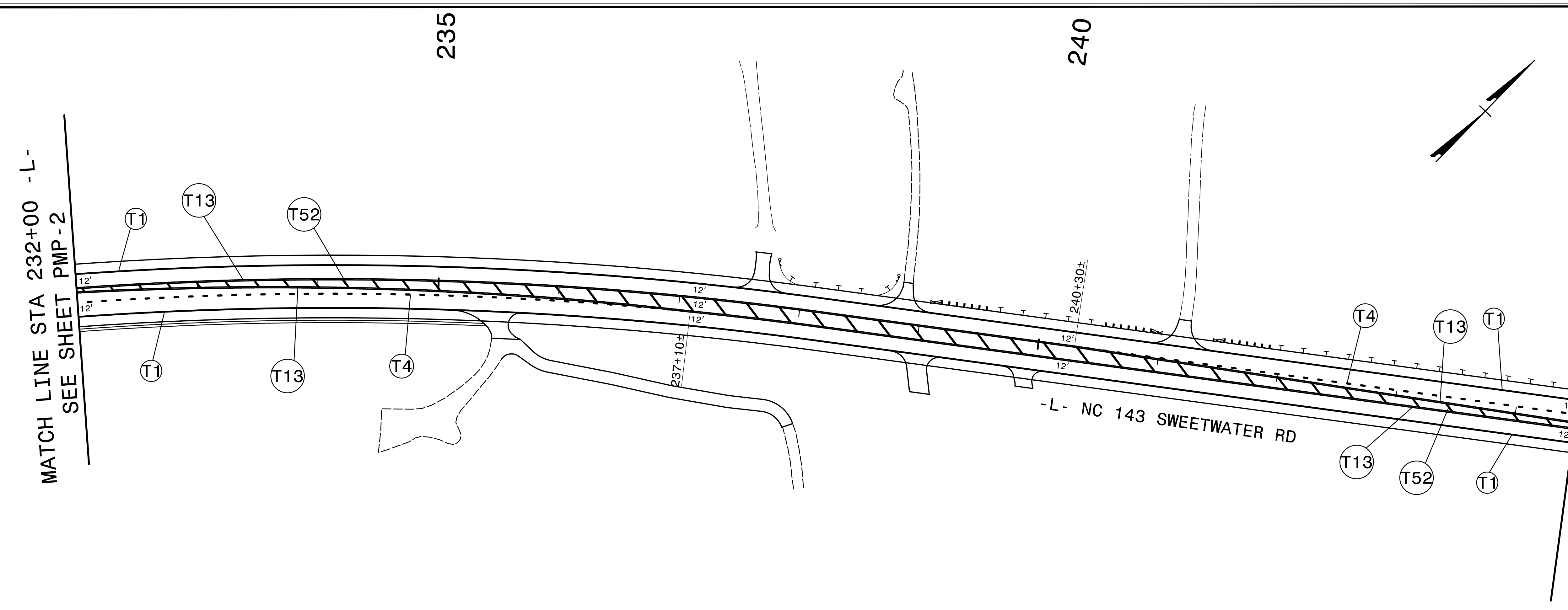

PAVEMENT MARKING SYMBOLS

PAVEMENT MARKING DETAIL

5/23/2022
 X:\NC0001\A-0009CB\Pavement Markings\A-0009CB\A-0009CB_Sgn_PMP_03.dgn
 User:smelvin

TIP NO. A-0009CB	SHEET NO. PMP-4
APPROVED: <i>Jimmy Terry</i> FD36F3882E9400	
DATE: 7/27/2022	
SEAL	
DOCUMENT NOT CONSIDERED FINAL UNLESS ALL SIGNATURES COMPLETED	
TGS ENGINEERS 201 W. MARION ST., STE 200 SHELBY, NC 28150 PH: (704) 476-0003 CORP. LICENSE NO.: C-0275	

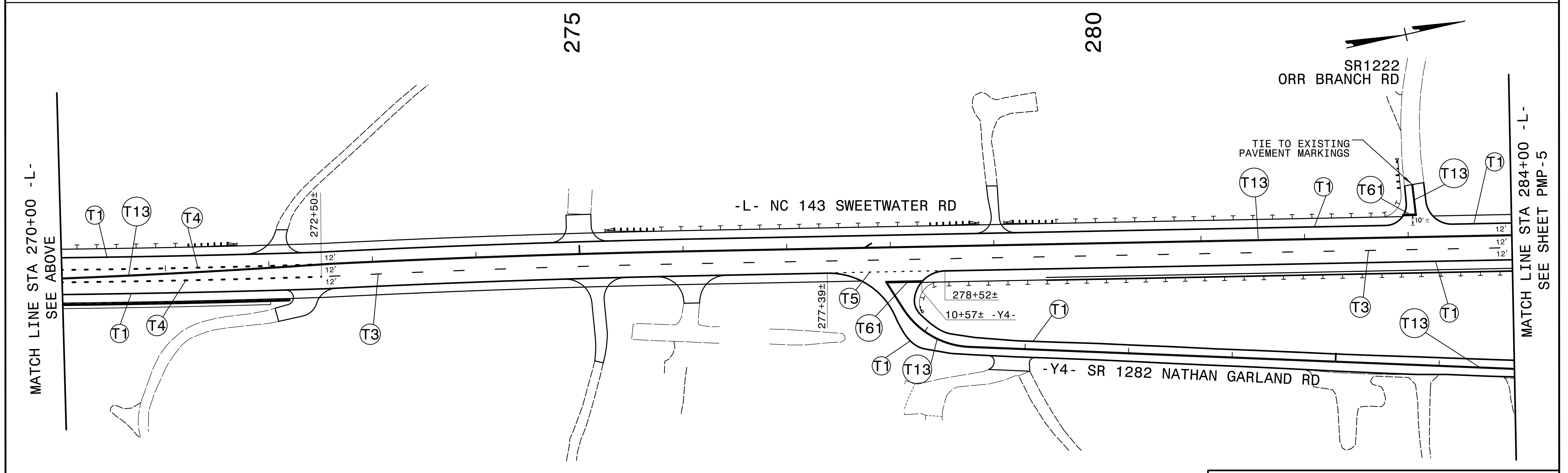
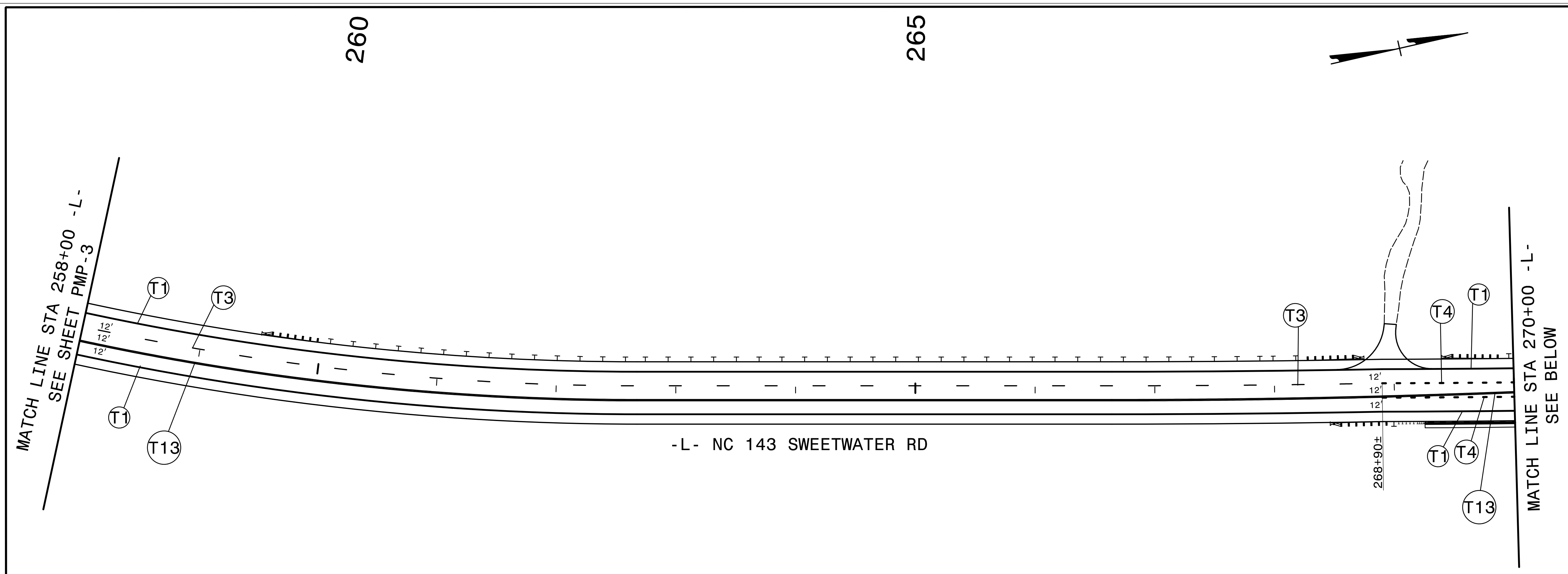

PAVEMENT MARKING DETAIL

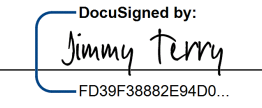
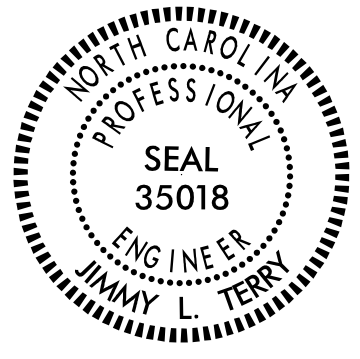

5/23/2022
X:\NC\001\A-0009CB\Pavement Markings\A-0009CB\A-0009CB_Sgn_PMP_04.dgn
User:smelvin

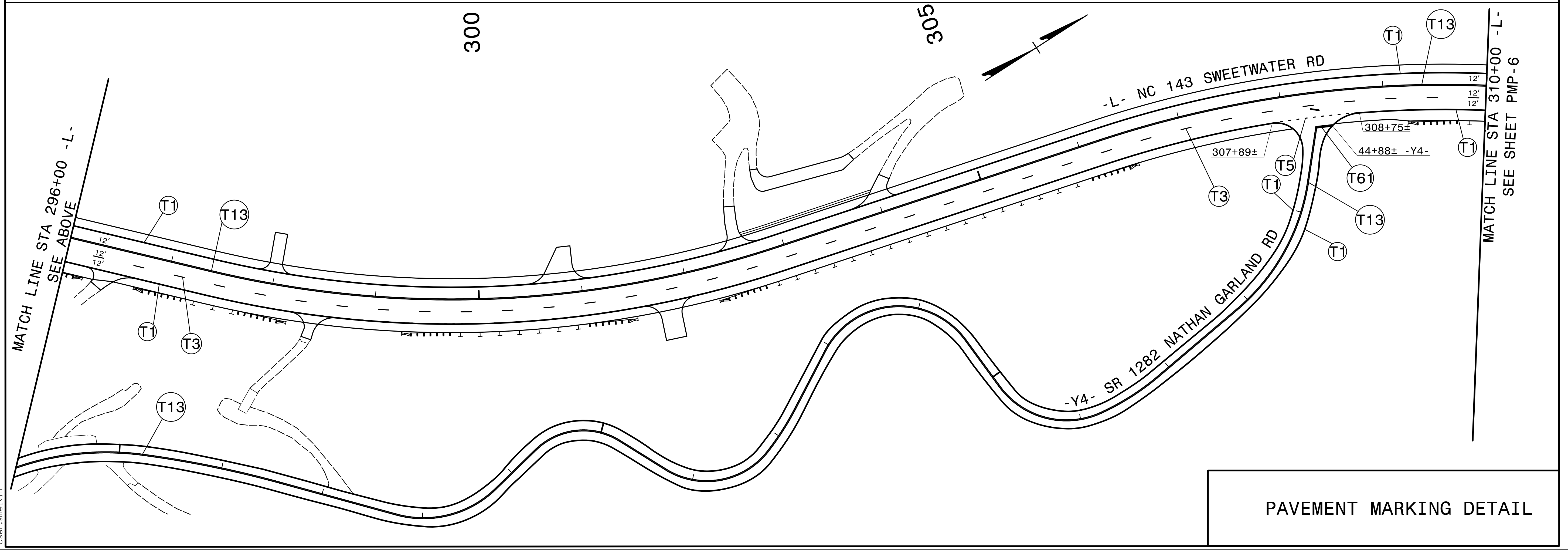
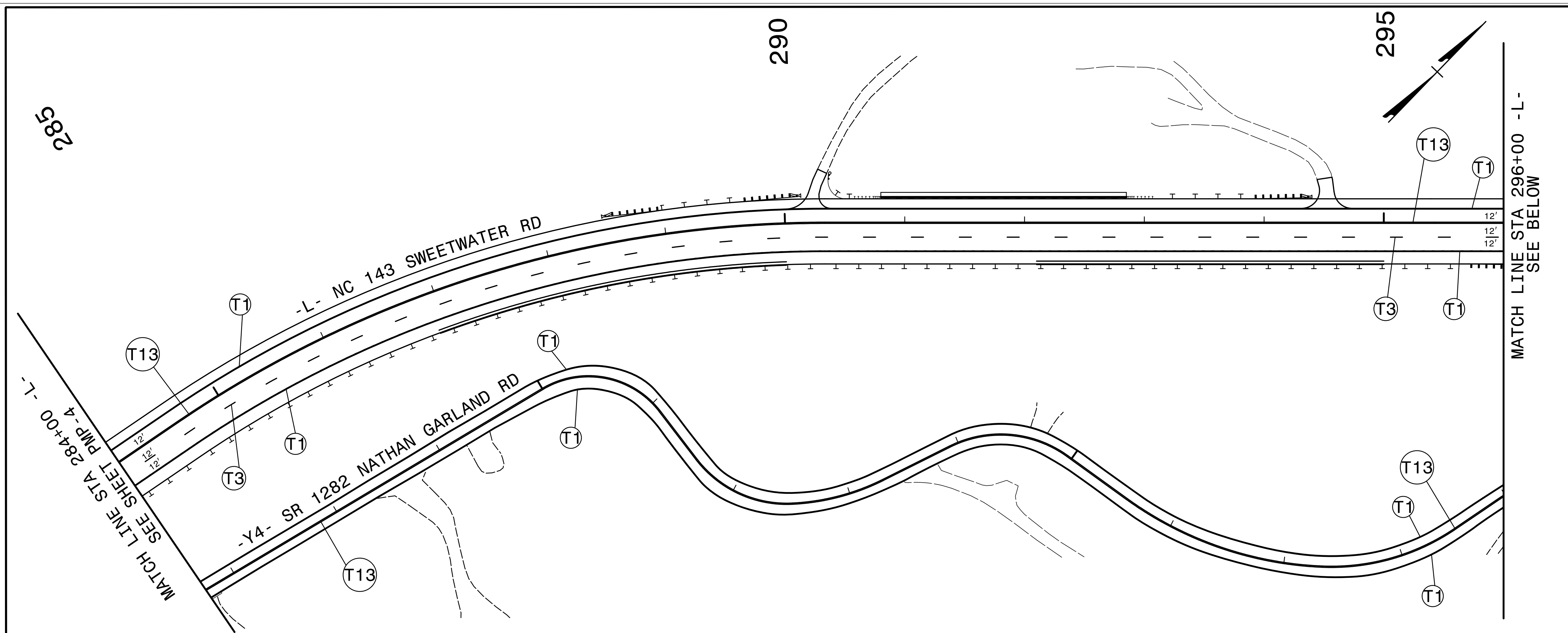
TIP NO. A-0009CB	SHEET NO. PMP-5
APPROVED:  DocuSigned by: Jimmy Terry F05E8882E94D0	
DATE: 7/27/2022	
SEAL 	
DOCUMENT NOT CONSIDERED FINAL UNLESS ALL SIGNATURES COMPLETED	
TGS ENGINEERS 201 W. MARION ST., STE 200 SHELBY, NC 28150 PH: (704) 476-0003 CORP. LICENSE NO.: C-0275	



PAVEMENT MARKING DETAIL

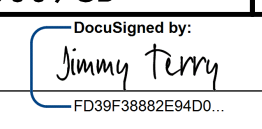

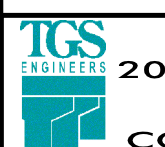
5/23/2022
X:\NC\001\A-0009CB\Pavement Markings\A-0009CB\A-0009CB_Sgn_PMP_05.dgn
User:smelvin

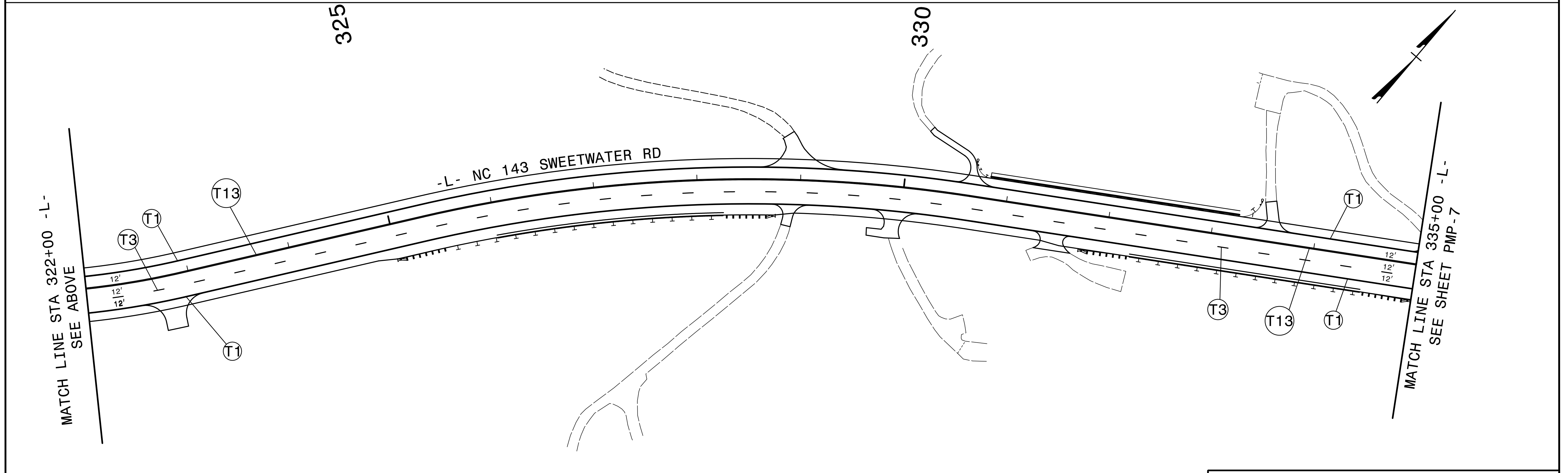
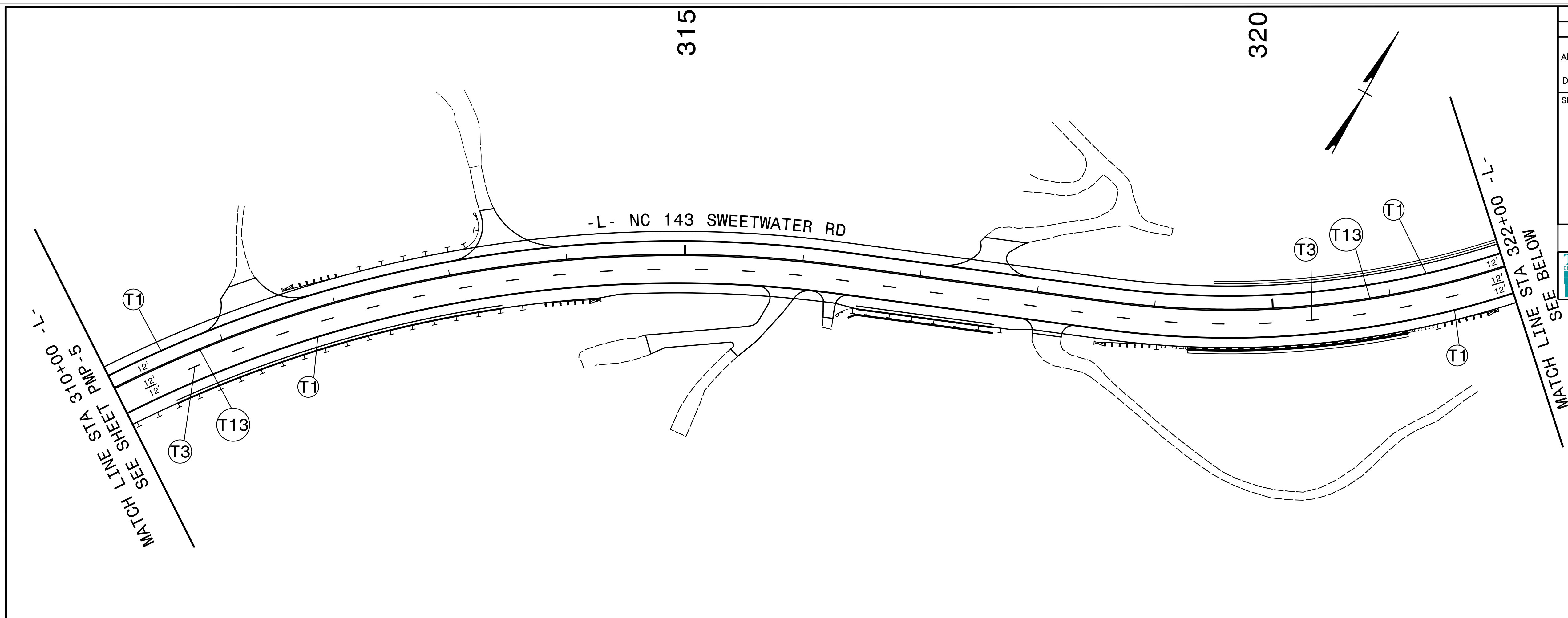
TIP NO. A-0009CB	SHEET NO. PMP-6
APPROVED:  FDSP#388026400	
DATE: 7/27/2022	
SEAL	
	
DOCUMENT NOT CONSIDERED FINAL UNLESS ALL SIGNATURES COMPLETED	
 TGS ENGINEERS 201 W. MARION ST., STE 200 SHELBY, NC 28150 PH: (704) 476-0003 CORP. LICENSE NO.: C-0275	



PAVEMENT MARKING DETAIL

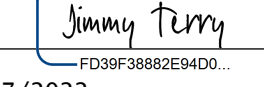

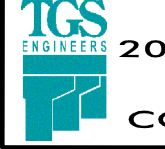
5/23/2022
X:\NC\001\A-0009CB\Pavement Markings\A-0009CB\A-0009CB_Sgn_PMP_06.dgn
User:smelvin

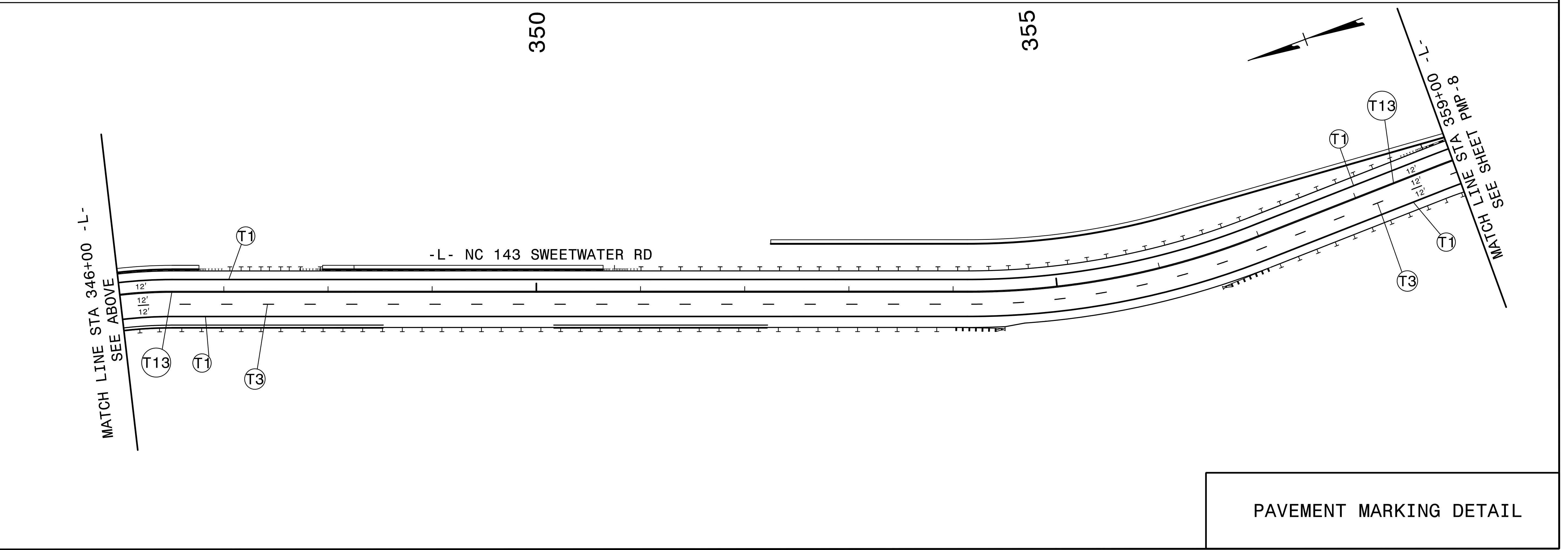
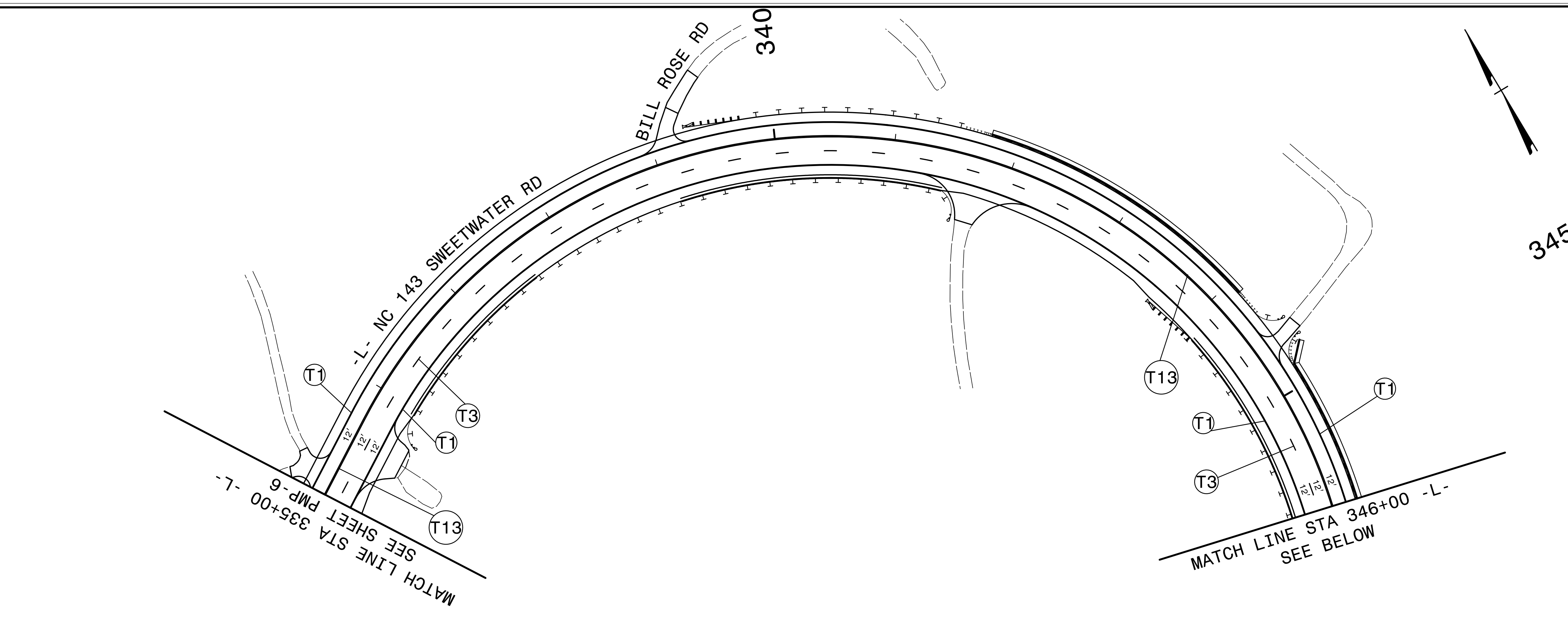
TIP NO. A-0009CB	SHEET NO. PMP-7
APPROVED:  FD39F388D2E54D0	
DATE: 7/27/2022	
SEAL	
	
DOCUMENT NOT CONSIDERED FINAL UNLESS ALL SIGNATURES COMPLETED	
 TGS ENGINEERS 201 W. MARION ST., STE 200 SHELBY, NC 28150 PH: (704) 476-0003 CORP. LICENSE NO.: C-0275	

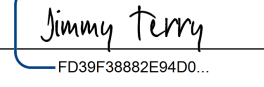

PAVEMENT MARKING DETAIL

5/23/2022
X:\NC001\A-0009CB\Pavement Markings\A-0009CB\A-0009CB_Sgn_PMP_07.dgn
User:smelvin

TIP NO. A-0009CB	SHEET NO. PMP-8
APPROVED:  DATE: 7/27/2022	
SEAL 	
DOCUMENT NOT CONSIDERED FINAL UNLESS ALL SIGNATURES COMPLETED	
TGS ENGINEERS 201 W. MARION ST., STE 200 SHELBY, NC 28150 PH: (704) 476-0003 CORP. LICENSE NO.: C-0275	

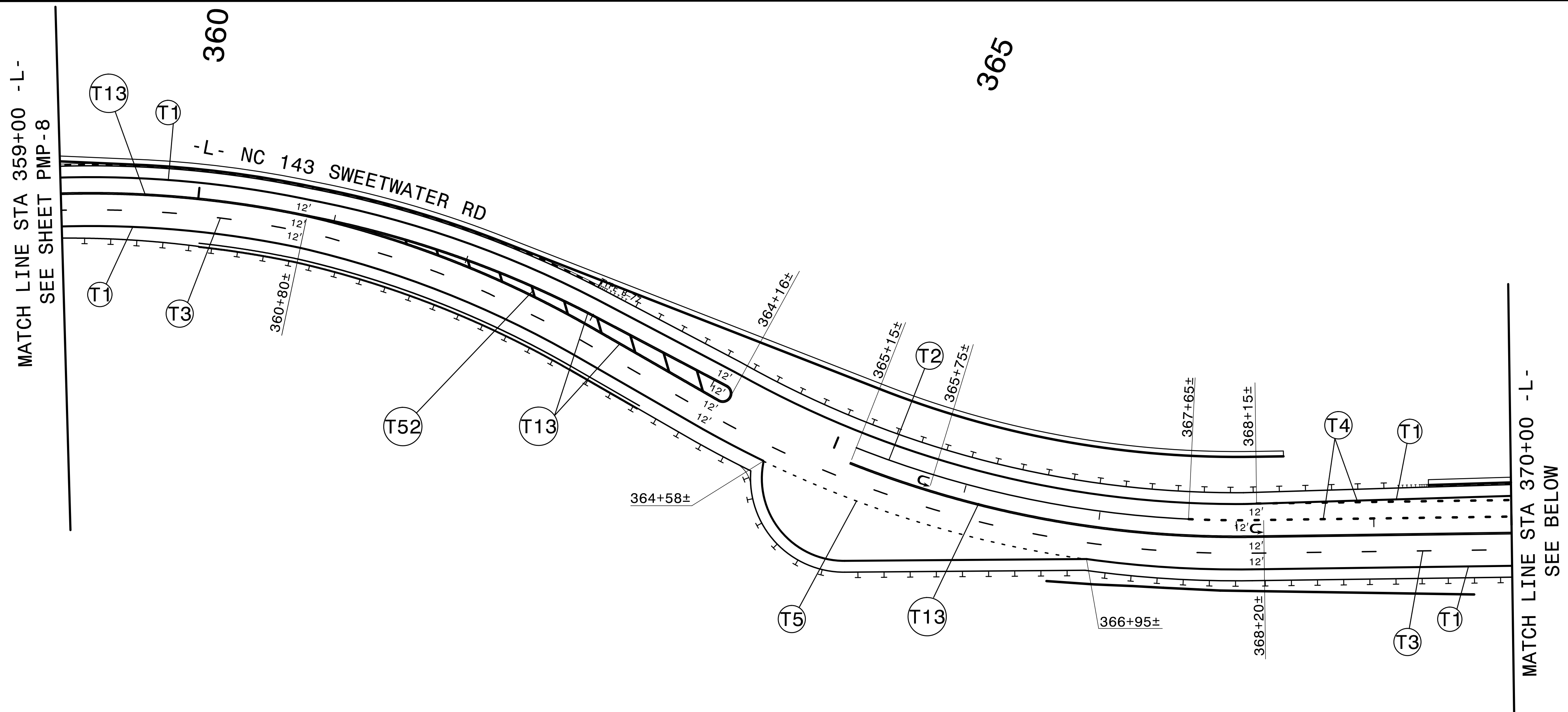

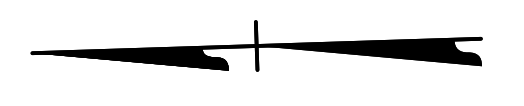
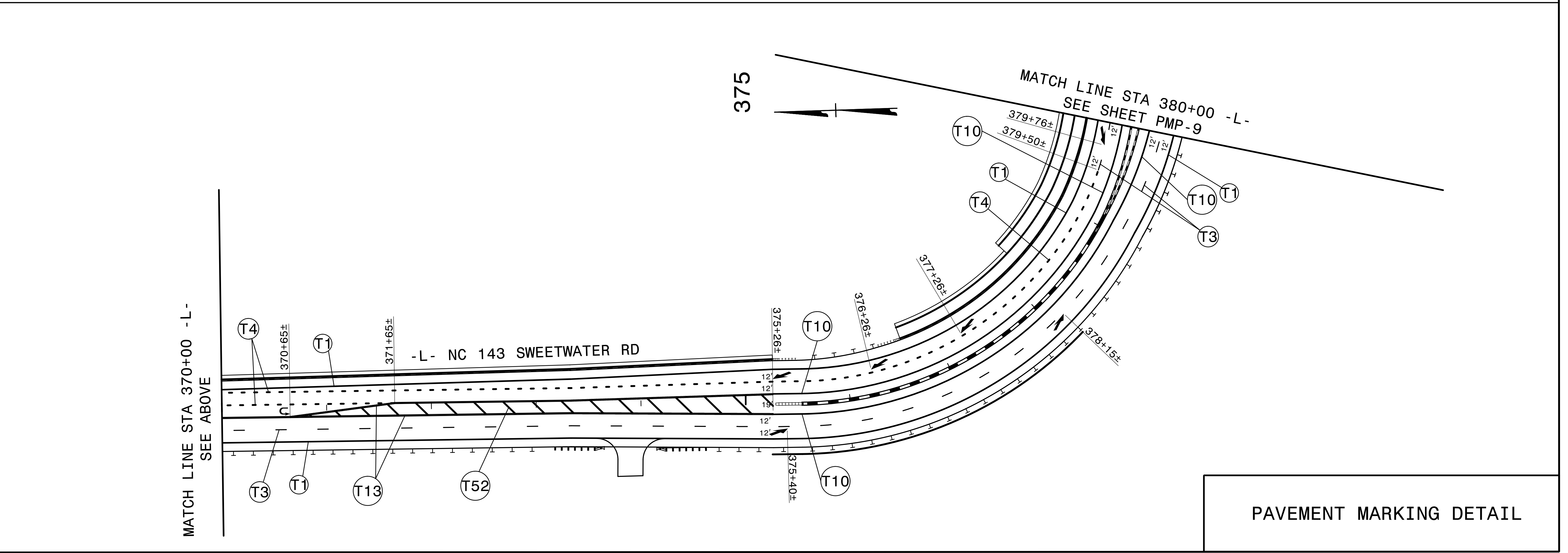
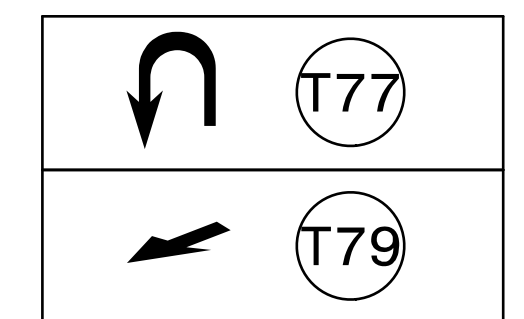

PAVEMENT MARKING SYMBOLS



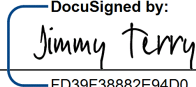

PAVEMENT MARKING DETAIL

5/23/2022
X:\NC0001\A-0009CB\Traffic\ Pavement Markings\A-0009CB\A-0009CB_Sgn_PMP_08.dgn
User:smelvin

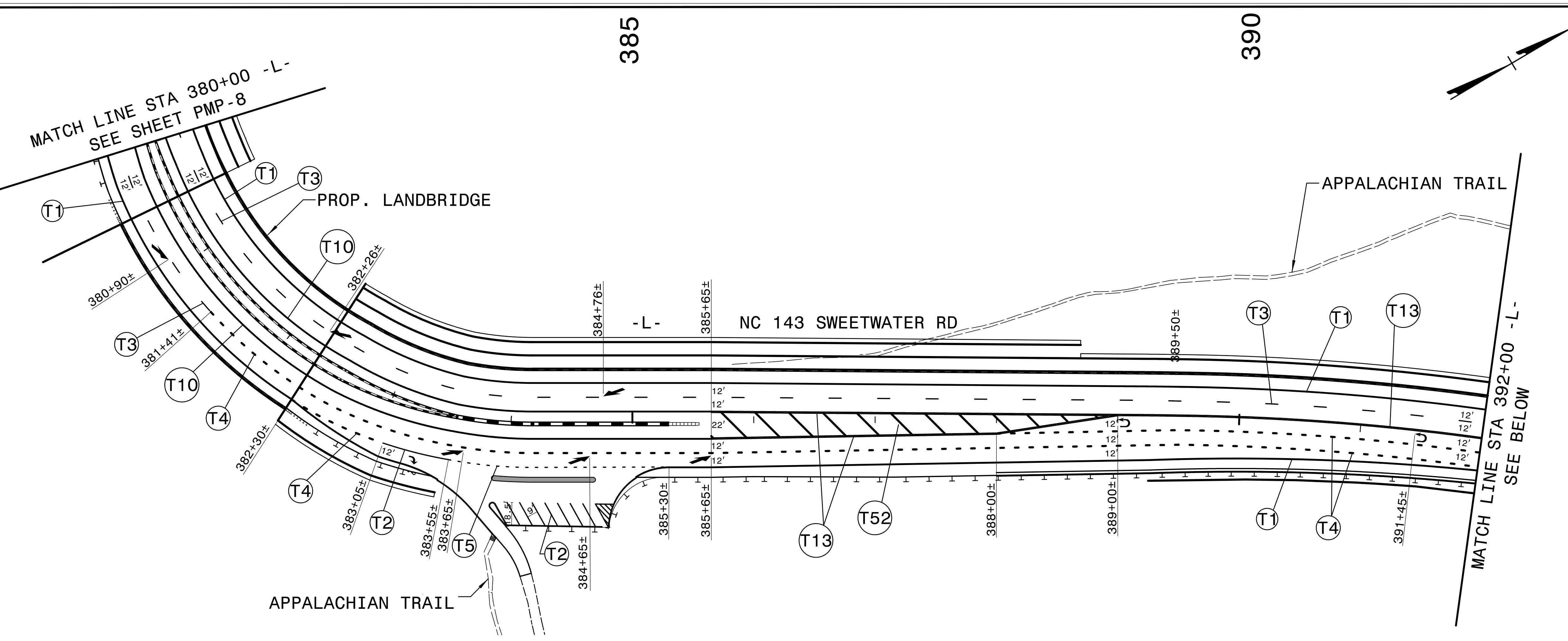
TIP NO. A-0009CB	SHEET NO. PMP-9
APPROVED:  7/27/2022	
DATE: 7/27/2022	
SEAL	
	
DOCUMENT NOT CONSIDERED FINAL UNLESS ALL SIGNATURES COMPLETED	
 TGS ENGINEERS 201 W. MARION ST., STE 200 SHELBY, NC 28150 PH: (704) 476-0003 CORP. LICENSE NO.: C-0275	



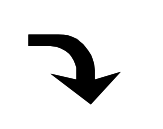
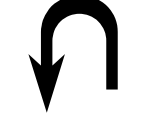

PAVEMENT MARKING SYMBOLS

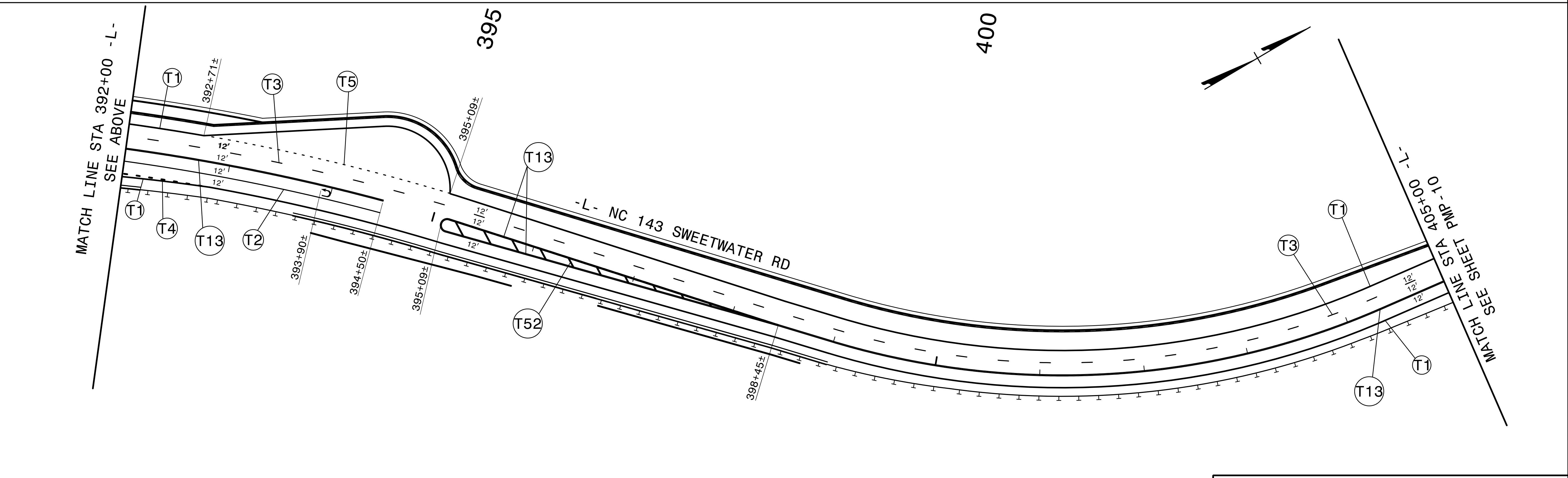
	T71
	T77
	T79

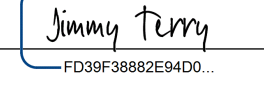

PAVEMENT MARKING DETAIL

5/23/2022
 X:\NC001\A-0009CB\Pavement Markings\A-0009CB\A-0009CB_Sgn_PMP_09.dgn
 User:smelvin

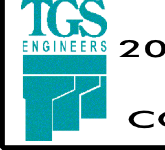
TIP NO. A-0009CB	SHEET NO. PMP-10
APPROVED:  F039F888E940D	
DATE: 7/27/2022	
SEAL	
	
DOCUMENT NOT CONSIDERED FINAL UNLESS ALL SIGNATURES COMPLETED	
 TGS ENGINEERS 201 W. MARION ST., STE 200 SHELBY, NC 28150 PH: (704) 476-0003 CORP. LICENSE NO.: C-0275	

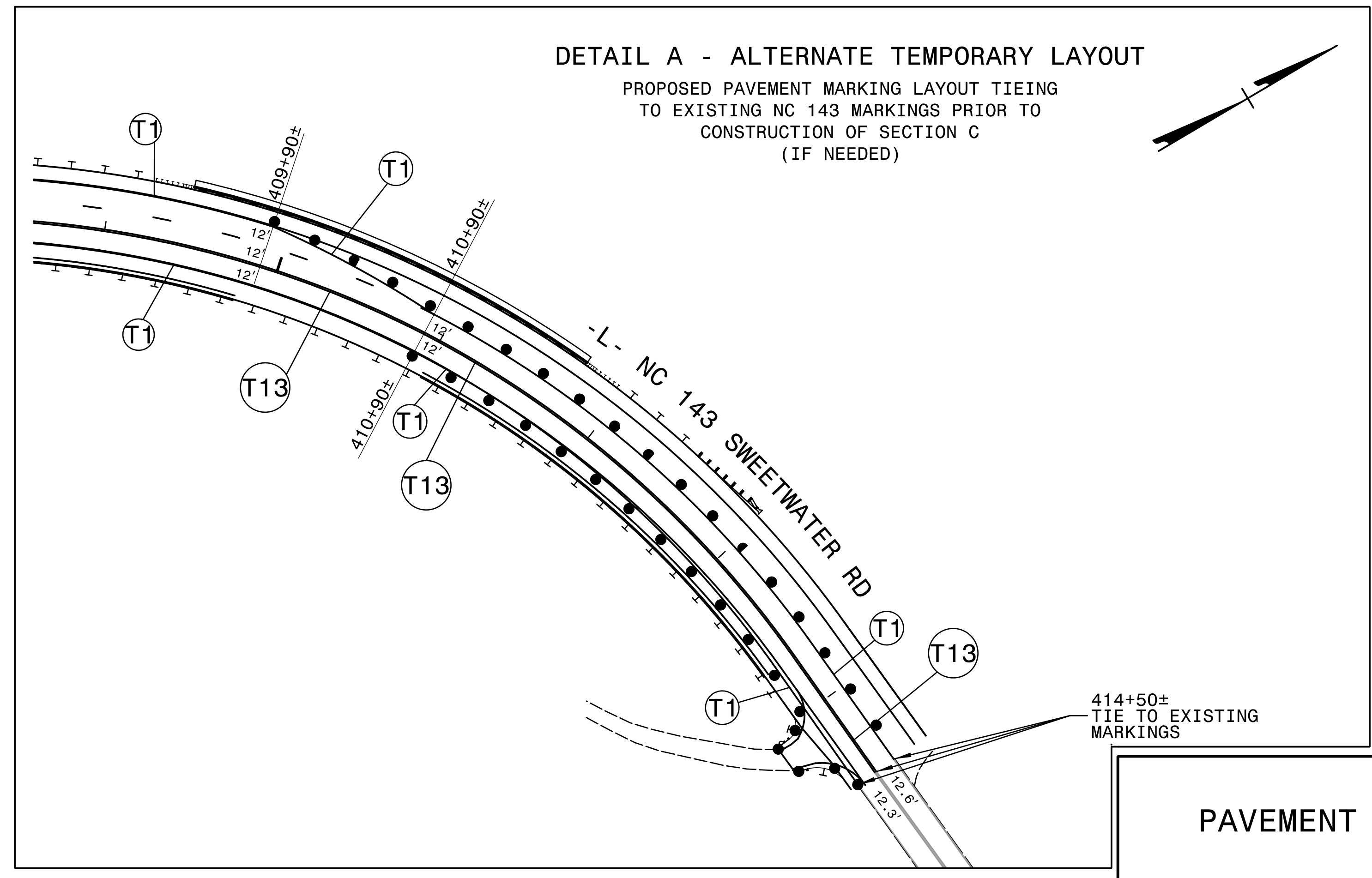
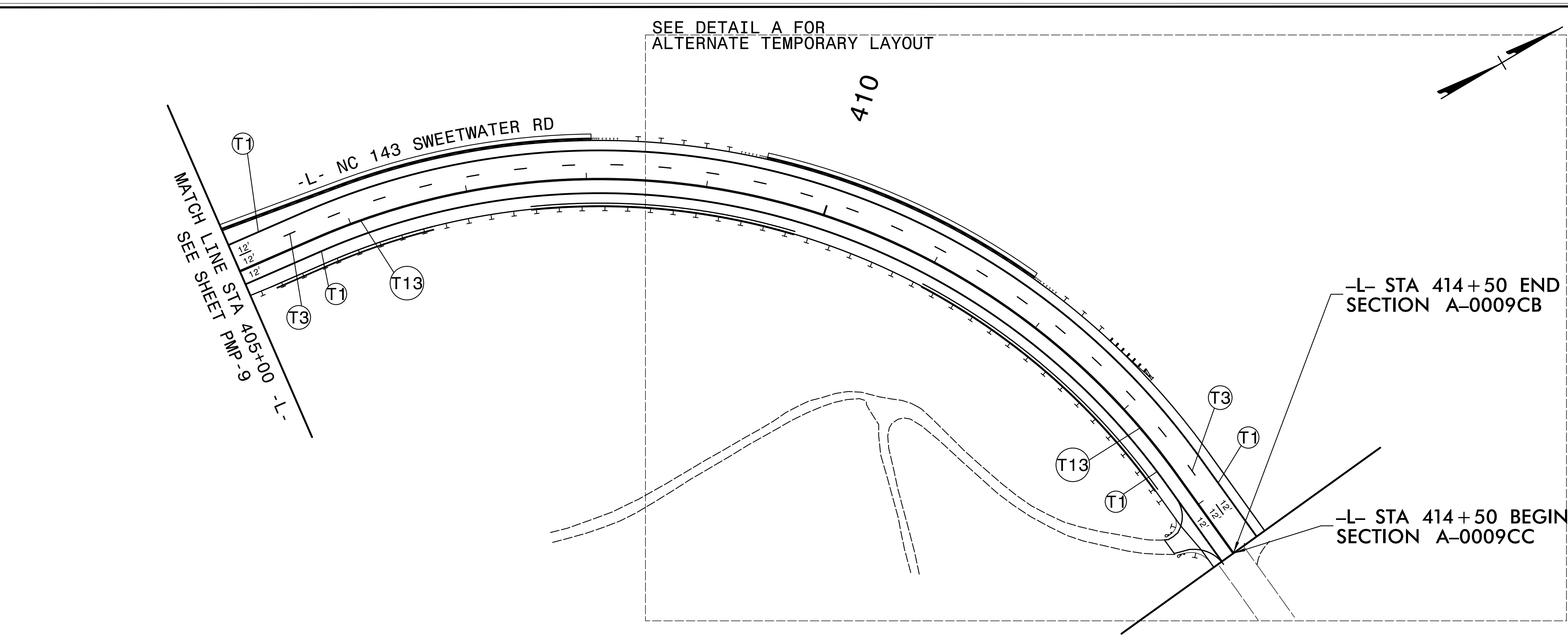

PAVEMENT MARKING DETAIL

5/23/2022 5:41:00 PM X:\NC001\A-0009CB\Pavement Markings\A-0009CB\A-0009CB_Sgn_PMP_10.dgn User:smelvin