

UTILITIES BY OTHERS

ALL PROPOSED UTILITY WORK, EXCEPT FOR THE INSTALLATION OF THE TWO FOUR-INCH CONDUITS, WILL BE DONE BY OTHERS. NO PAYMENT WILL BE MADE TO THE CONTRACTOR FOR PROPOSED UTILITY WORK SHOWN ON THIS SHEET, EXCEPT AS NOTED IN THE CONTRACT FOR THE CONDUITS. SEE THE UO PROVISIONS AND THE INSTALLATION OF CONDUITS PROVISION FOR ADDITIONAL INFORMATION.

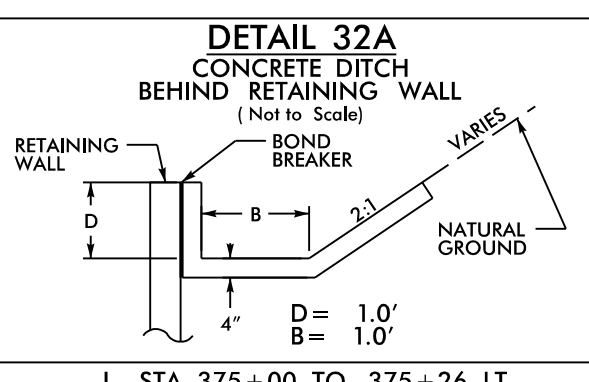
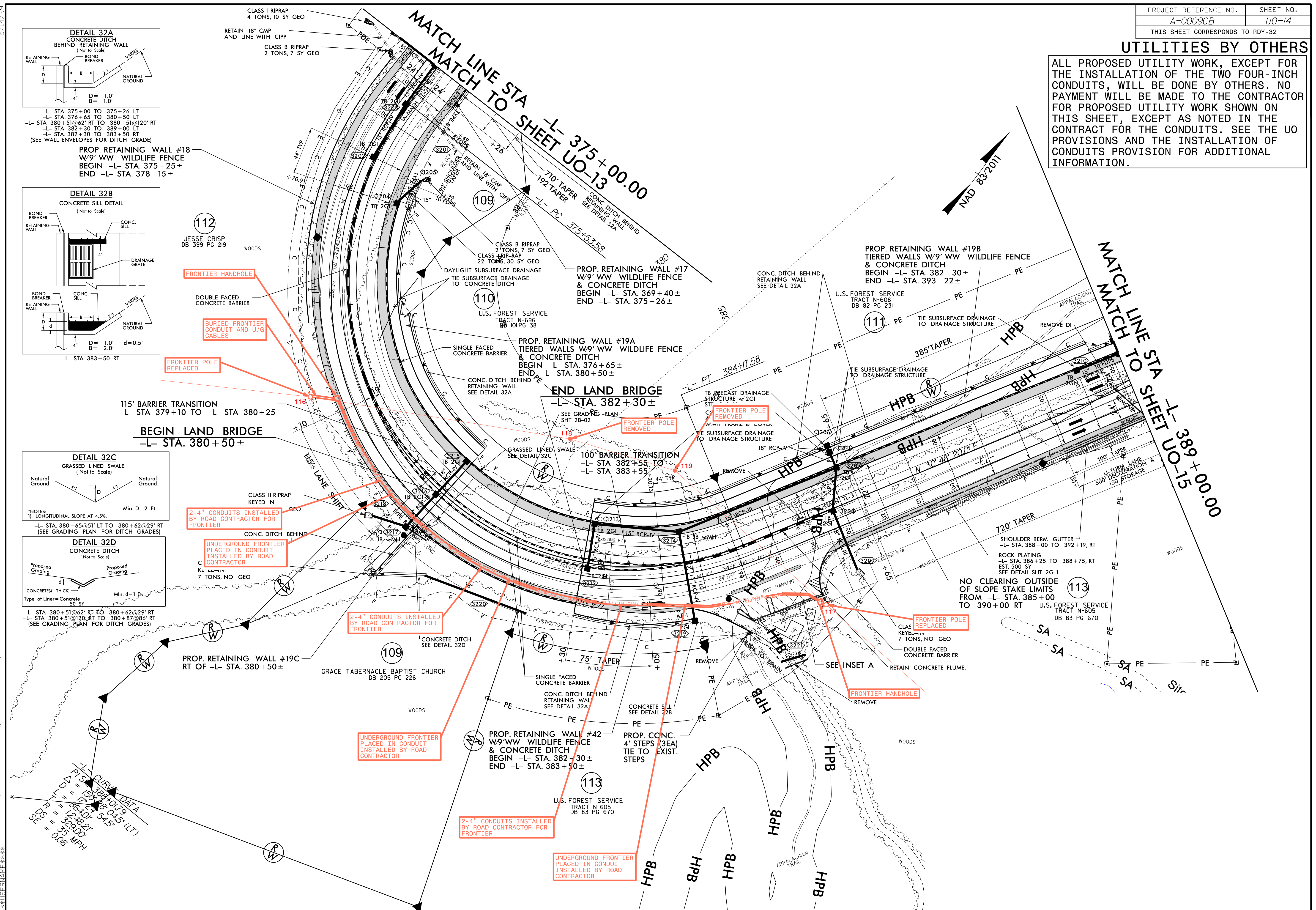

DETAIL 32A
CONCRETE DITCH BEHIND RETAINING WALL
(Not to Scale)

-L- STA. 375+00 TO 375+26 LT
 -L- STA. 376+65 TO 380+50 LT
 -L- STA. 380+51@62' RT TO 380+51@120' RT
 -L- STA. 382+30 TO 389+00 LT
 -L- STA. 387+30 TO 383+50 RT
 (SEE WALL ENVELOPES FOR DITCH GRADE)

PROF. RETAINING WALL #18
W/9' WW WILDLIFE FENCE
BEGIN -L- STA. 375+25±
END -L- STA. 378+15±

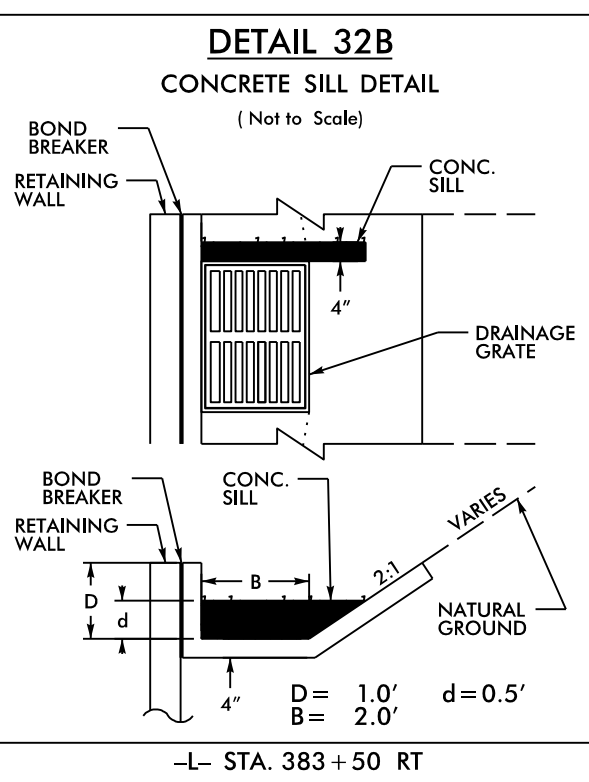

DETAIL 32B
CONCRETE SILL DETAIL
(Not to Scale)

-L- STA. 383+50 RT

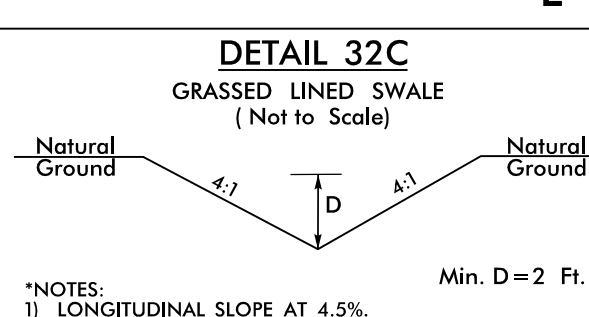

DETAIL 32C
GRASSED LINED SWALE
(Not to Scale)

Min. D = 2 Ft.

1) LONGITUDINAL SLOPE AT 4.5%

-L- STA. 380+65@51' LT TO 380+62@29' RT
 (SEE GRADING PLAN FOR DITCH GRADES)

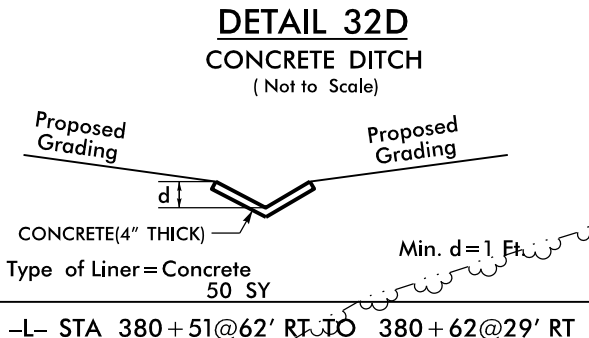

DETAIL 32D
CONCRETE DITCH
(Not to Scale)

Min. d = 1 Ft.

Type of Liner = Concrete 50 SY

-L- STA. 380+51@62' RT TO 380+62@29' RT
 -L- STA. 380+51@120' RT TO 380+87@86' RT
 (SEE GRADING PLAN FOR DITCH GRADES)

5/14/2019

 15-JUL-2022 15:30
 (TGS)\\S:\Projects\Engineering\U00\Proj\A-0009CB\U0-14_psh.dgn
 32A
 15-JUL-2022 15:30
 (TGS)\\S:\Projects\Engineering\U00\Proj\A-0009CB\U0-14_psh.dgn
 32B
 15-JUL-2022 15:30
 (TGS)\\S:\Projects\Engineering\U00\Proj\A-0009CB\U0-14_psh.dgn
 32C
 15-JUL-2022 15:30
 (TGS)\\S:\Projects\Engineering\U00\Proj\A-0009CB\U0-14_psh.dgn
 32D
 15-JUL-2022 15:30
 (TGS)\\S:\Projects\Engineering\U00\Proj\A-0009CB\U0-14_psh.dgn
 32E

