

UTILITIES BY OTHERS

ALL PROPOSED UTILITY WORK SHOWN ON THIS SHEET WILL BE DONE BY OTHERS. NO PAYMENT WILL BE MADE TO THE CONTRACTOR FOR PROPOSED UTILITY WORK SHOWN ON THIS SHEET.

-L- CURVE DATA

PI Sta 320+83.09	PI Sta 328+01.63
$\Delta = 32^{\circ} 27' 42.9''$ (LT)	$\Delta = 21^{\circ} 44' 00.0''$ (RT)
$D = 7^{\circ} 32' 20.1''$	$D = 4^{\circ} 05' 33.2''$
$L = 430.59'$	$L = 531.05'$
$T = 221.25'$	$T = 268.75'$
$R = 760.00'$	$R = 1,400.00'$
$SE = 0.08$	$SE = 0.08$
$DS = 50$ MPH	$DS = 60$ MPH

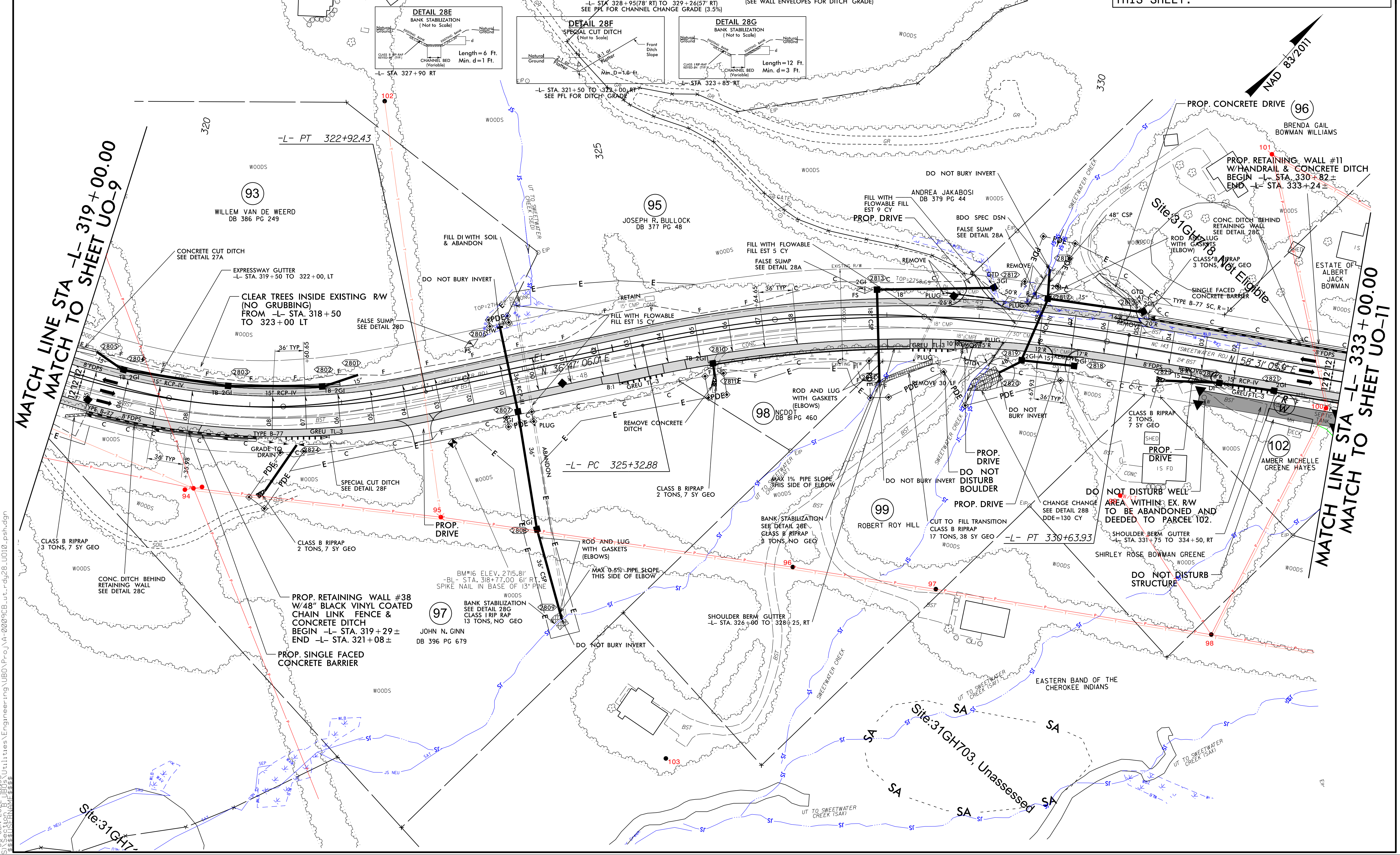
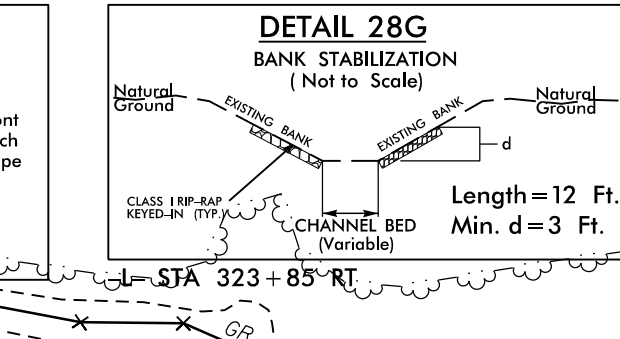
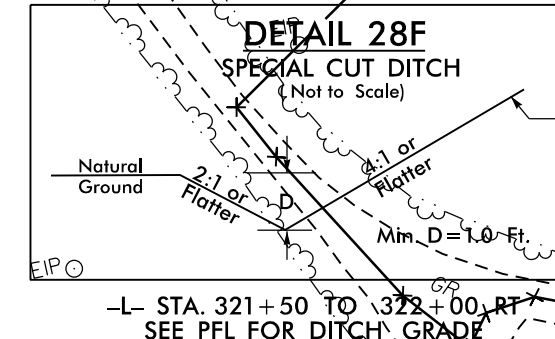
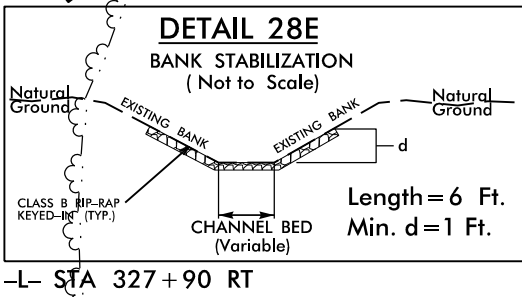
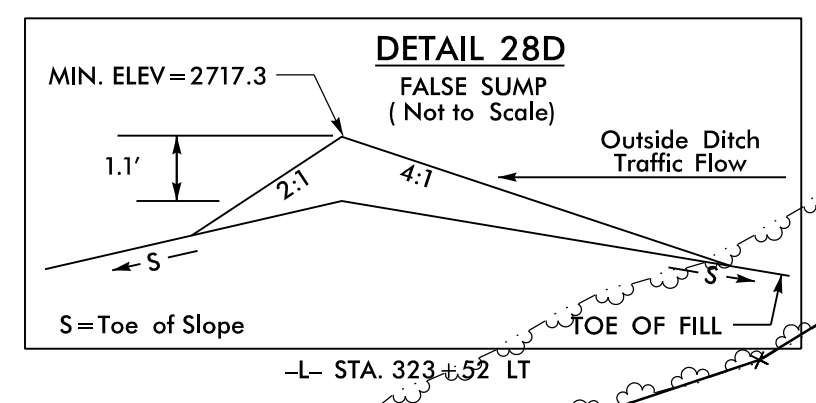
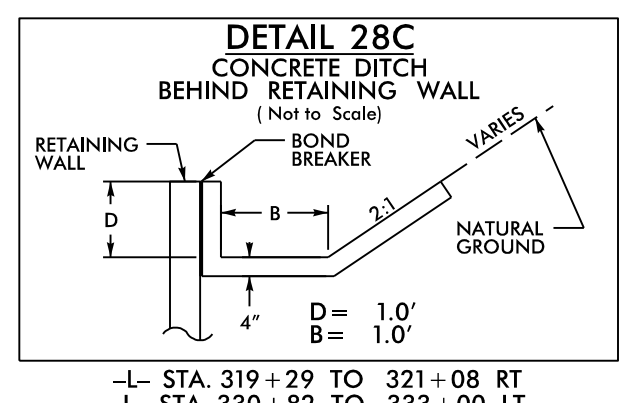
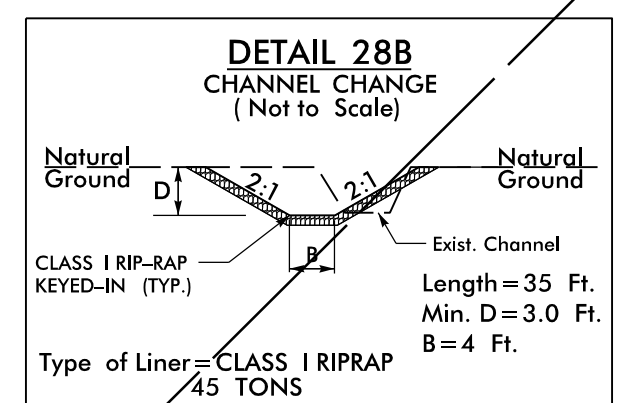
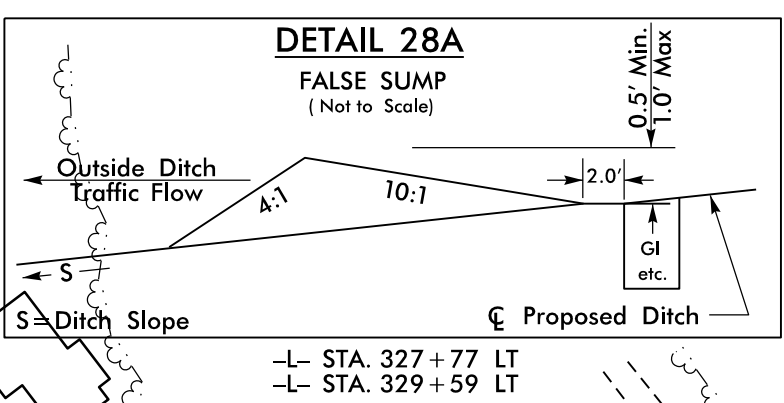

03-JUN-2022 09:35:36 H:\Utilities\Engineering\UB00\ProJ\A-0009CB\ut_rdy28_U010_psh.dgn

5/14/2019