

UTILITIES BY OTHERS

ALL PROPOSED UTILITY WORK SHOWN ON THIS SHEET WILL BE DONE BY OTHERS. NO PAYMENT WILL BE MADE TO THE CONTRACTOR FOR PROPOSED UTILITY WORK SHOWN ON THIS SHEET.

-L- CURVE DATA

PI Sta 311+70.00 Δ = 54° 45' 45.1" (RT) D = 5' 24' 18.9" L = 1,013.13' T = 549.01' R = 1,060.00' SE = 0.08 DS = 55 MPH	PI Sta 320+83.09 Δ = 32° 27' 42.9" (LT) D = 7' 32' 20.1" L = 430.59' T = 221.25' R = 760.00' SE = 0.08 DS = 50 MPH	PI Sta 40+76.38 Δ = 78° 16' 33.1" (LT) D = 7' 37' 11.0" L = 109.29' T = 65.10' R = 80.00'	PI Sta 41+53.87 Δ = 15° 47' 56.9" (LT) D = 23° 52' 23.7" L = 66.18' T = 33.30' R = 240.00'	PI Sta 43+61.39 Δ = 41° 05' 30.0" (LT) D = 28° 38' 52.4" L = 143.44' T = 74.96' R = 200.00'
---	---	--	---	--

① -Y4- PCC 41+20.57
② -Y4- PT 41+86.75
③ -Y4- PC 42+86.43
④ -Y4- PT 44+29.86

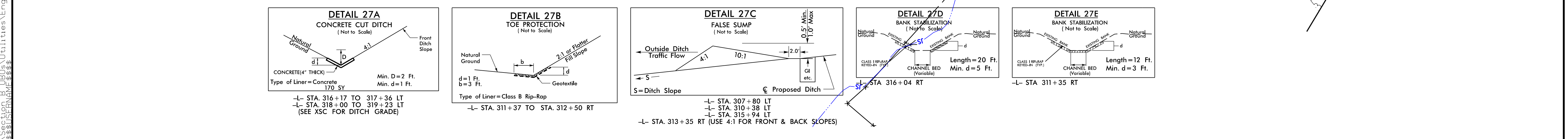
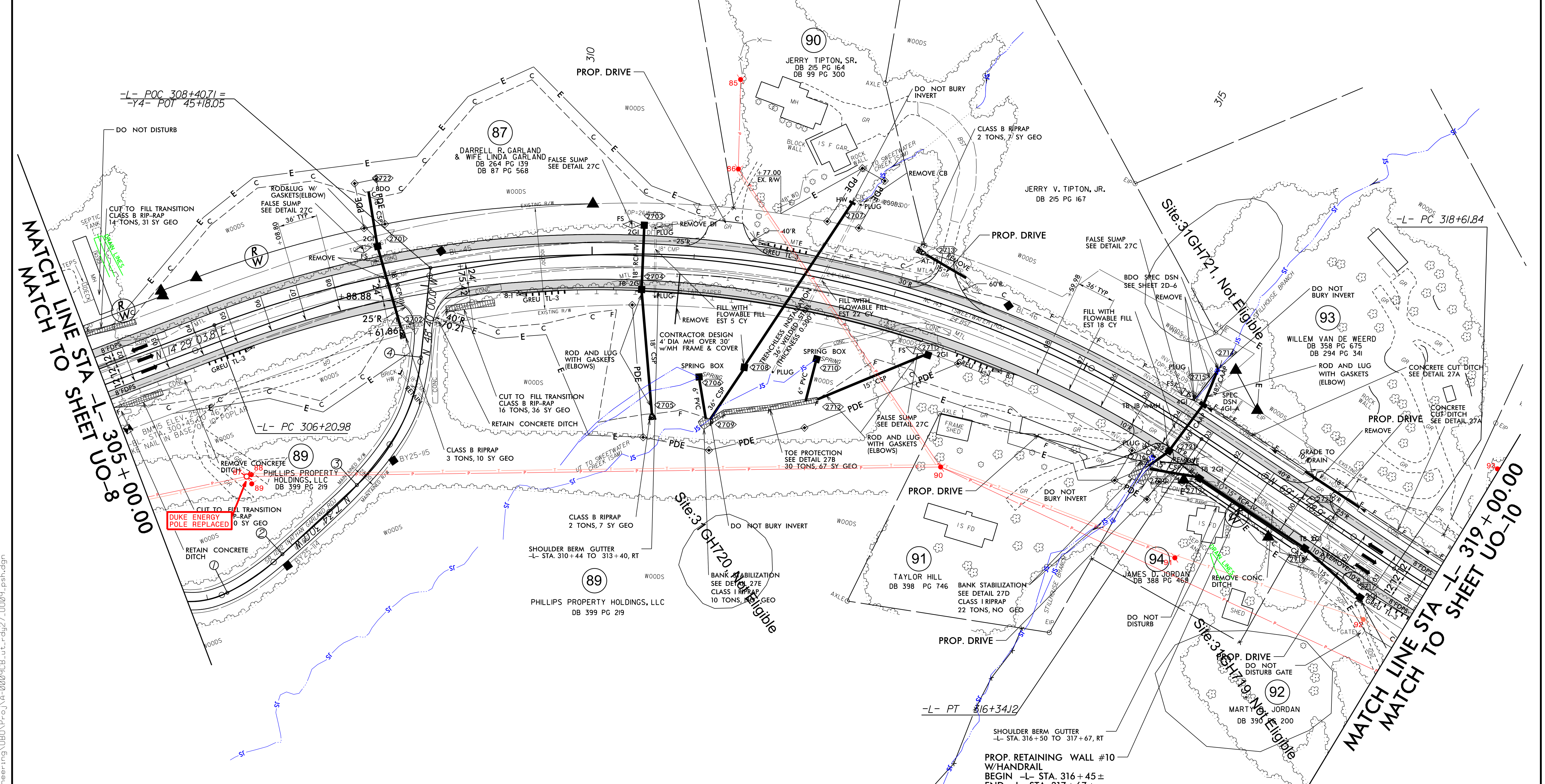

02-JUN-2022 2:20:00 Section B Utilities\Engineer\mg\UBOVPro\A-A-0009CB-ut.r.dwg U009_psh.dgn