

07/09/97

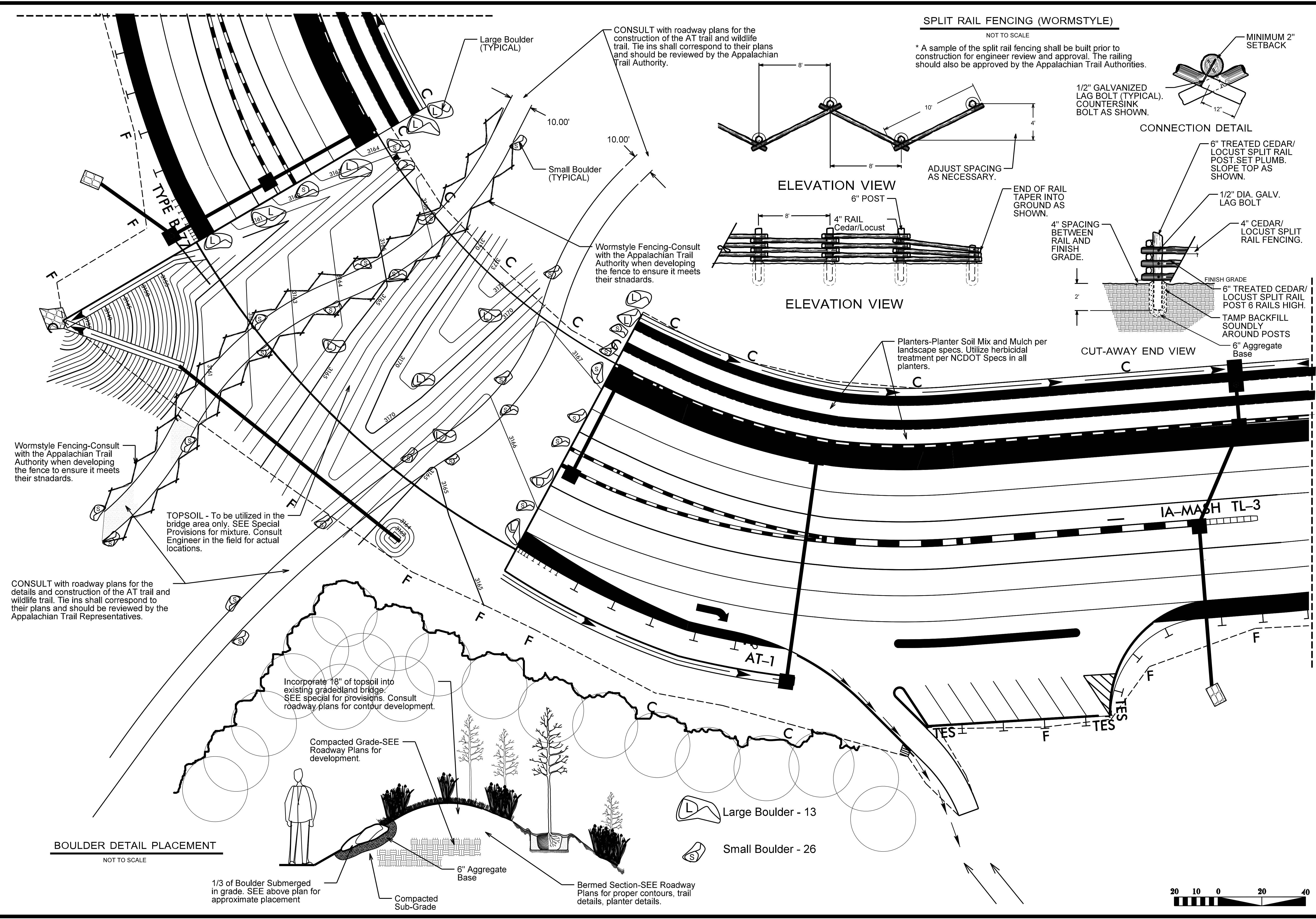
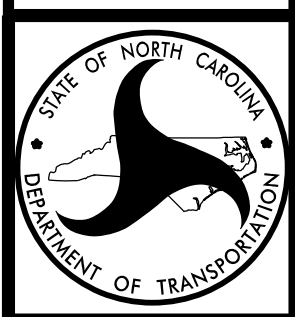

SPLIT RAIL FENCING (WORMSTYLE)

NOT TO SCALE

* A sample of the split rail fencing shall be built prior to construction for engineer review and approval. The railing should also be approved by the Appalachian Trail Authorities.

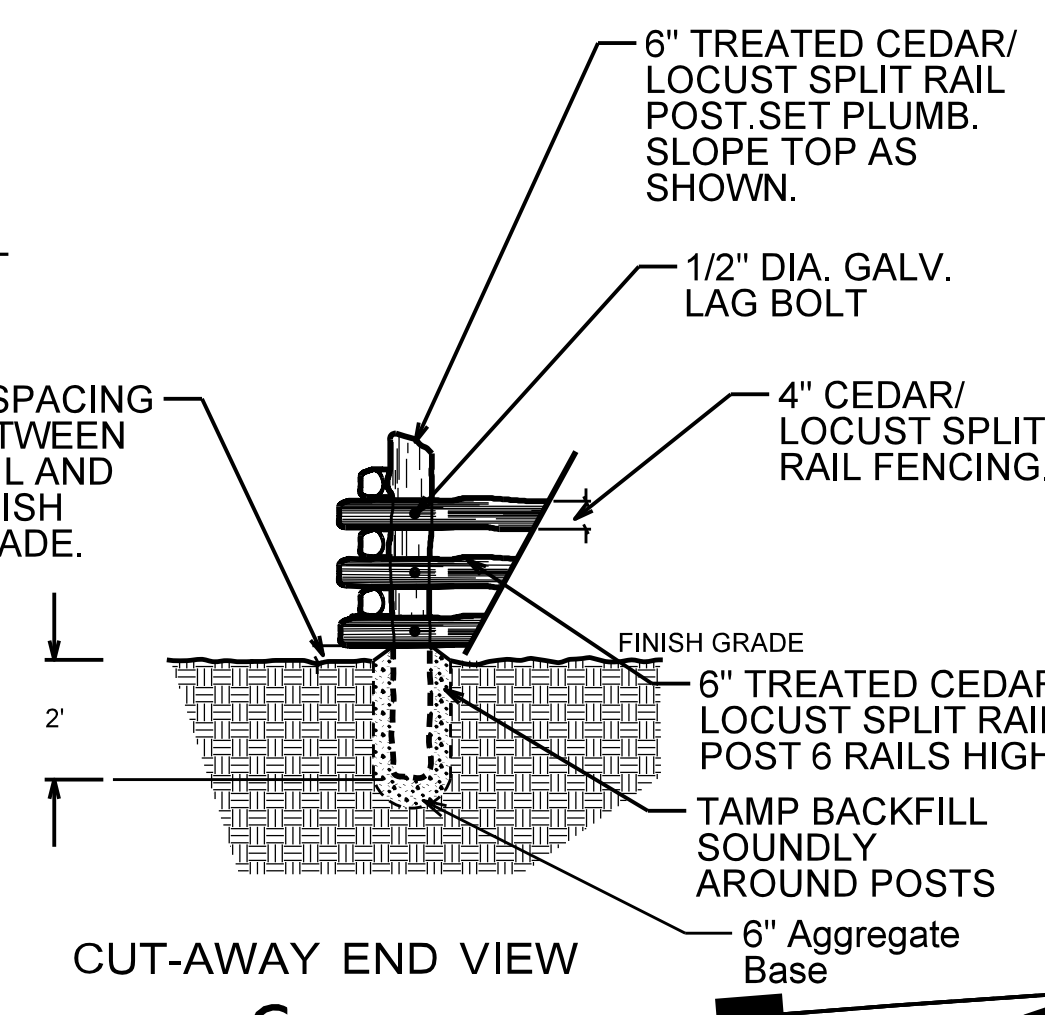
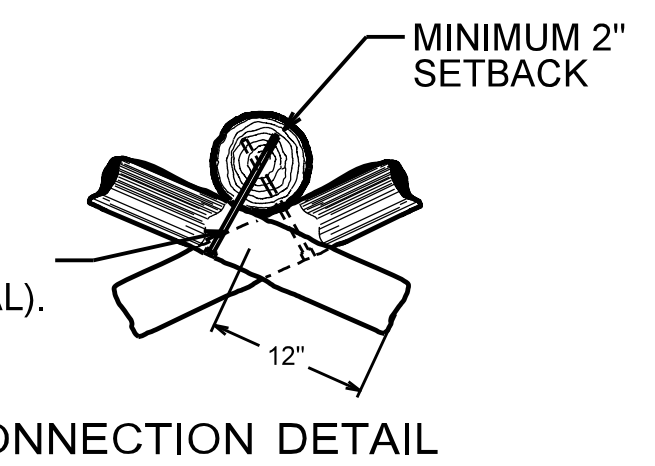
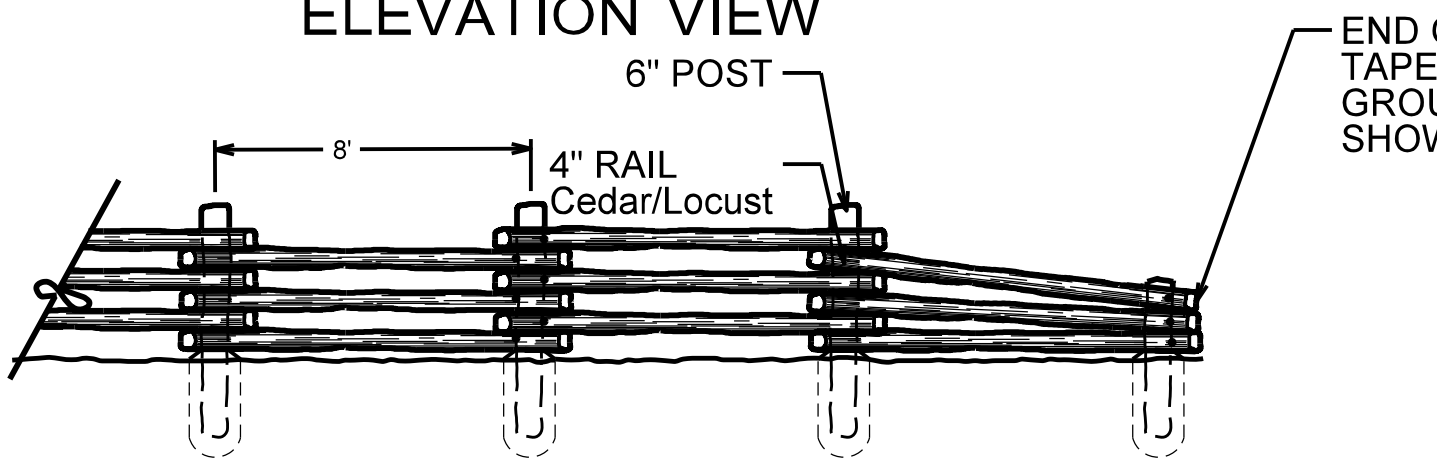
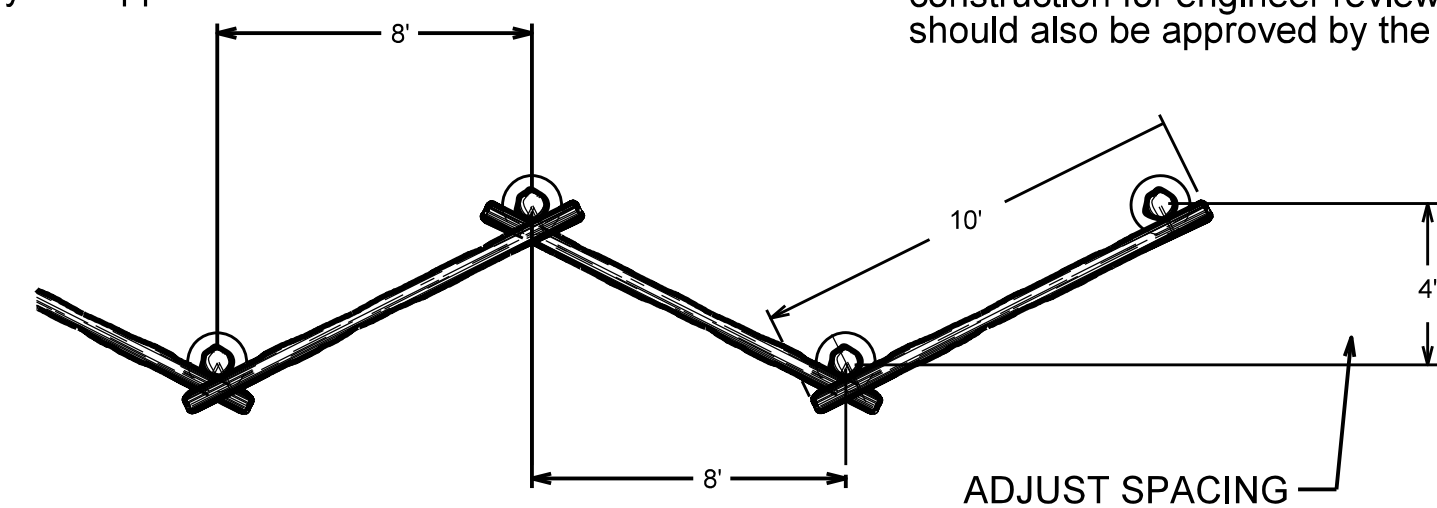

Wormstyle Fencing-Consult with the Appalachian Trail Authority when developing the fence to ensure it meets their standards.

TOPSOIL - To be utilized in the bridge area only. SEE Special Provisions for mixture. Consult Engineer in the field for actual locations.

CONSULT with roadway plans for the details and construction of the AT trail and wildlife trail. Tie ins shall correspond to their plans and should be reviewed by the Appalachian Trail Representatives.

Incorporate 18" of topsoil into existing gradedland bridge. SEE special for provisions. Consult roadway plans for contour development.

Compacted Grade-SEE Roadway Plans for development.

BOULDER DETAIL PLACEMENT

NOT TO SCALE

1/3 of Boulder Submerged in grade. SEE above plan for approximate placement

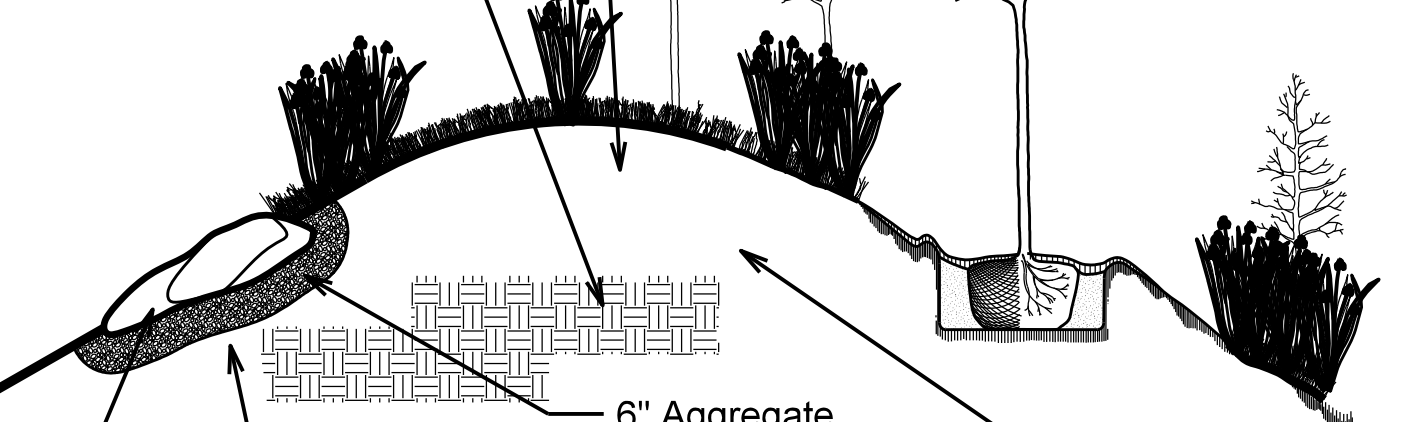
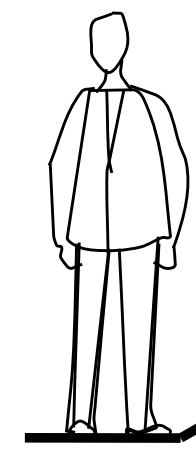

Large Boulder - 13

Small Boulder - 26

