

NOTE

THE CONTRACTOR SHALL FIELD VERIFY THE EXISTING JOINT OPENING PRIOR TO ORDERING JOINT SEAL MATERIAL. IF ACTUAL JOINT OPENING VARIES FROM THE OPENING INDICATED IN DETAIL BY MORE THAN 1/4", NOTIFY ENGINEER. REVISION TO THE JOINT SEAL SIZE MIGHT BE NECESSARY.

FINAL JOINT SEALS SHALL NOT BE INSTALLED UNTIL THE OVERLAY IS COMPLETE.

THE CONTRACTOR SHALL TAKE CARE DURING JOINT REHAB OPERATIONS NOT TO DROP ANY MATERIAL BELOW THE BRIDGE WITHOUT PROTECTIVE DEVICES BELOW TO CATCH THE MATERIAL. ANY MATERIAL THAT FALLS BELOW THE BRIDGE SHALL BE CONTAINED, REMOVED AND DISPOSED OF BY THE CONTRACTOR AT NO EXTRA COST TO THE DEPARTMENT. IF THE ENGINEER DETERMINES THAT THE PROTECTIVE DEVICES ARE NOT ADEQUATE OR NOT BEING EMPLOYED, THE WORK SHALL BE SUSPENDED UNTIL ADEQUATE PROTECTION IS PROVIDED.

THE CONTRACTOR WILL NOT BE PERMITTED TO FORM THE JOINTS IN LIEU OF SAWING THE JOINT.

THE INSTALLATION OF THE JOINT SEAL SHALL BE WATERTIGHT.

DURING THE JOINT INSTALLATION PROCEDURE, THE JOINT AND SURROUNDING AREA SHALL BE KEPT CLEAN AND FREE OF DEBRIS.

THE MANUFACTURER IS TO PROVIDE THE NOMINAL UNCOMPRESSED SEAL WIDTH OF THE FOAM JOINT SEAL FOR THE SIZE OF THE OPENING ON THE PLANS AND THAT ACCOMMODATE THE MINIMUM EXPANSION SHOWN ON THE PLANS.

A MANUFACTURER'S CERTIFIED TRAINED REPRESENTATIVE SHALL BE PRESENT DURING THE INSTALLATION OF THE FIRST JOINT OF THE PROJECT, OR UNTIL THE ENGINEER IS SATISFIED WITH THE INSTALL PROCESS.

FINAL SURFACE OF THE JOINT DEMOLITION AREA PRIOR TO PLACEMENT OF CONCRETE REPAIR MATERIAL SHOULD BE REASONABLY FLAT AND LEVEL. ENGINEER SHALL DETERMINE THE ACCEPTABILITY OF THE SURFACE PRIOR TO PLACEMENT OF REPAIR CONCRETE.

FOR FOAM JOINT SEALS FOR PRESERVATION, SEE SPECIAL PROVISIONS.

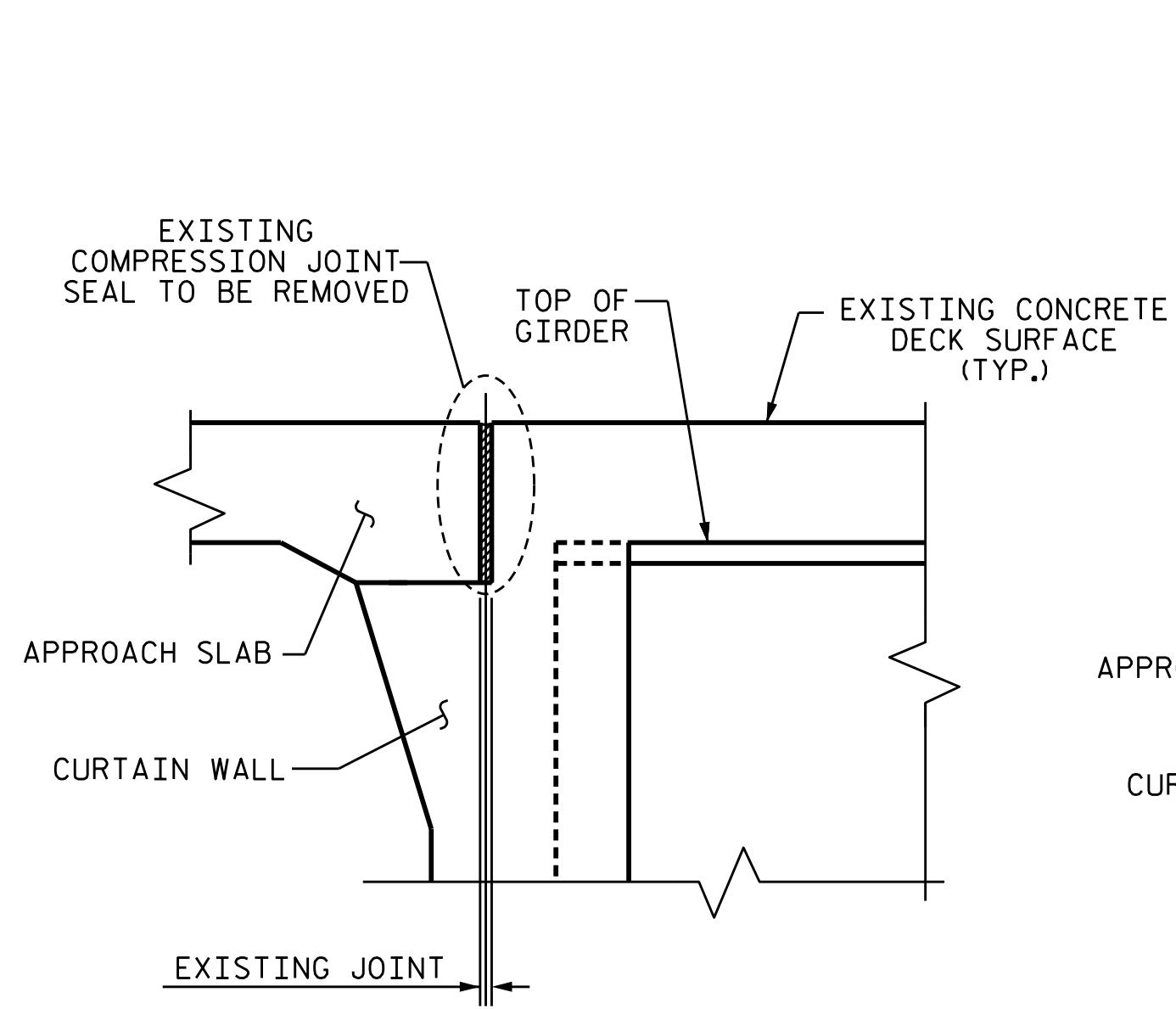

EXISTING JOINT

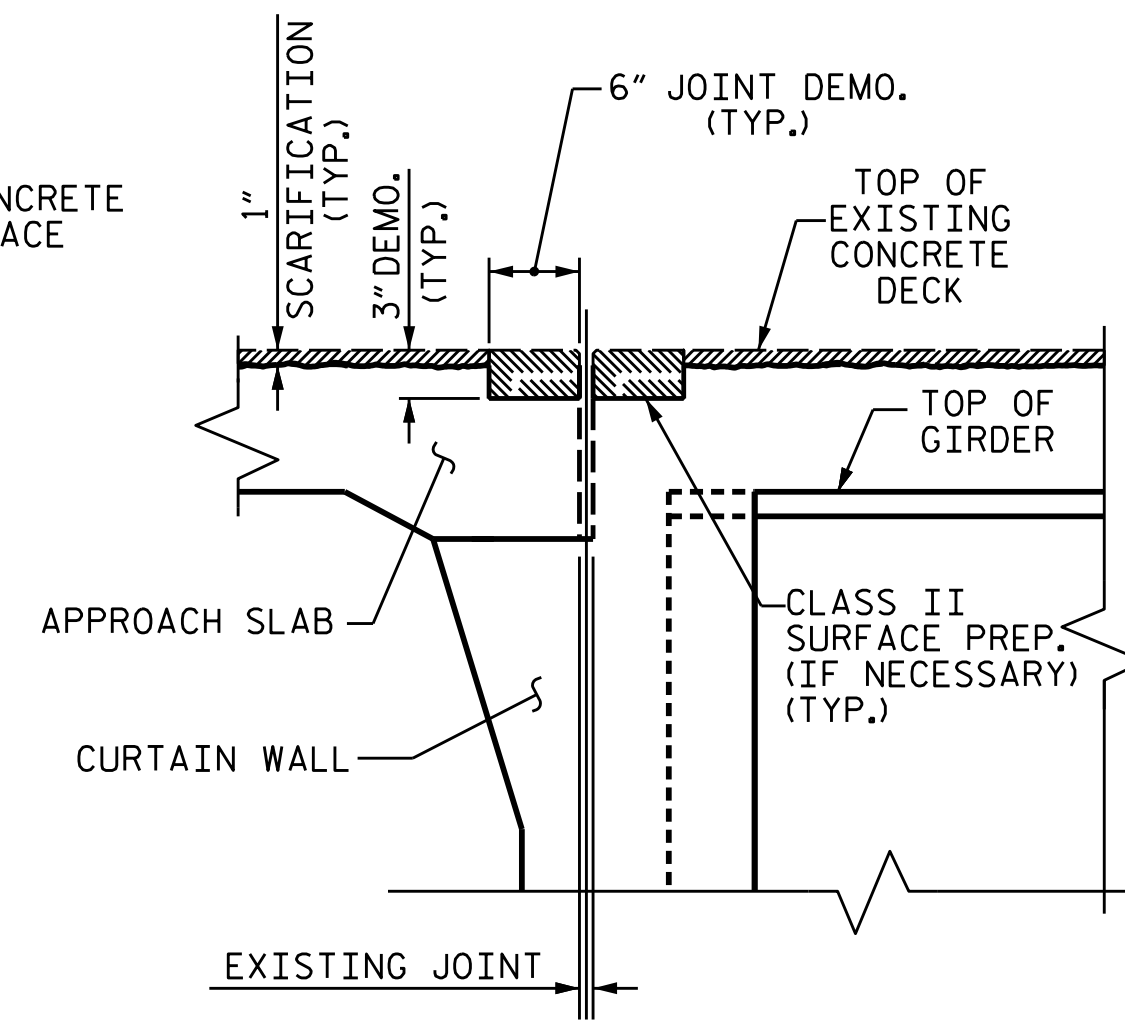

MINIMUM EXISTING JOINT DEMOLITION & SCARIFICATION

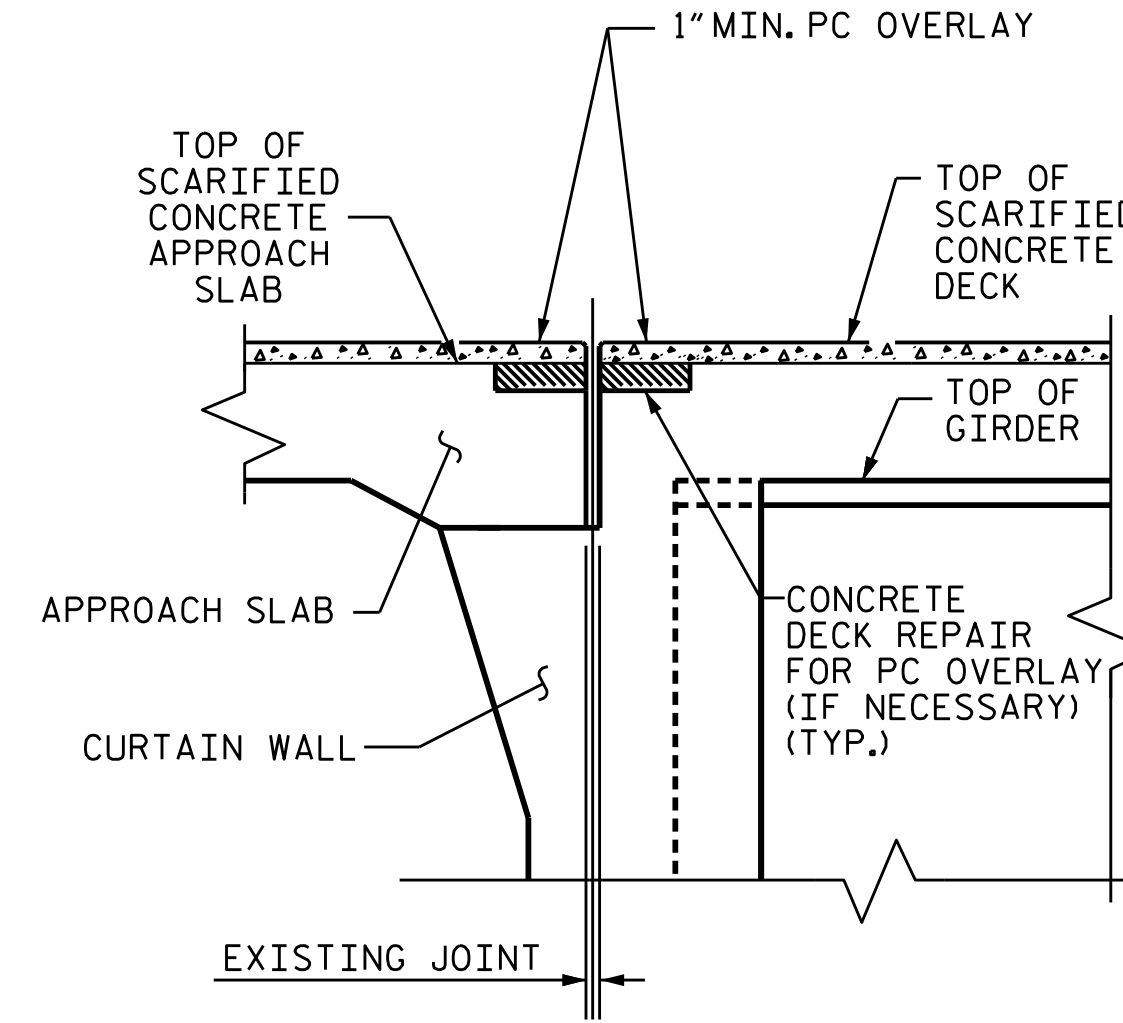

PROPOSED JOINT PRE-SAWED & PC OVERLAY

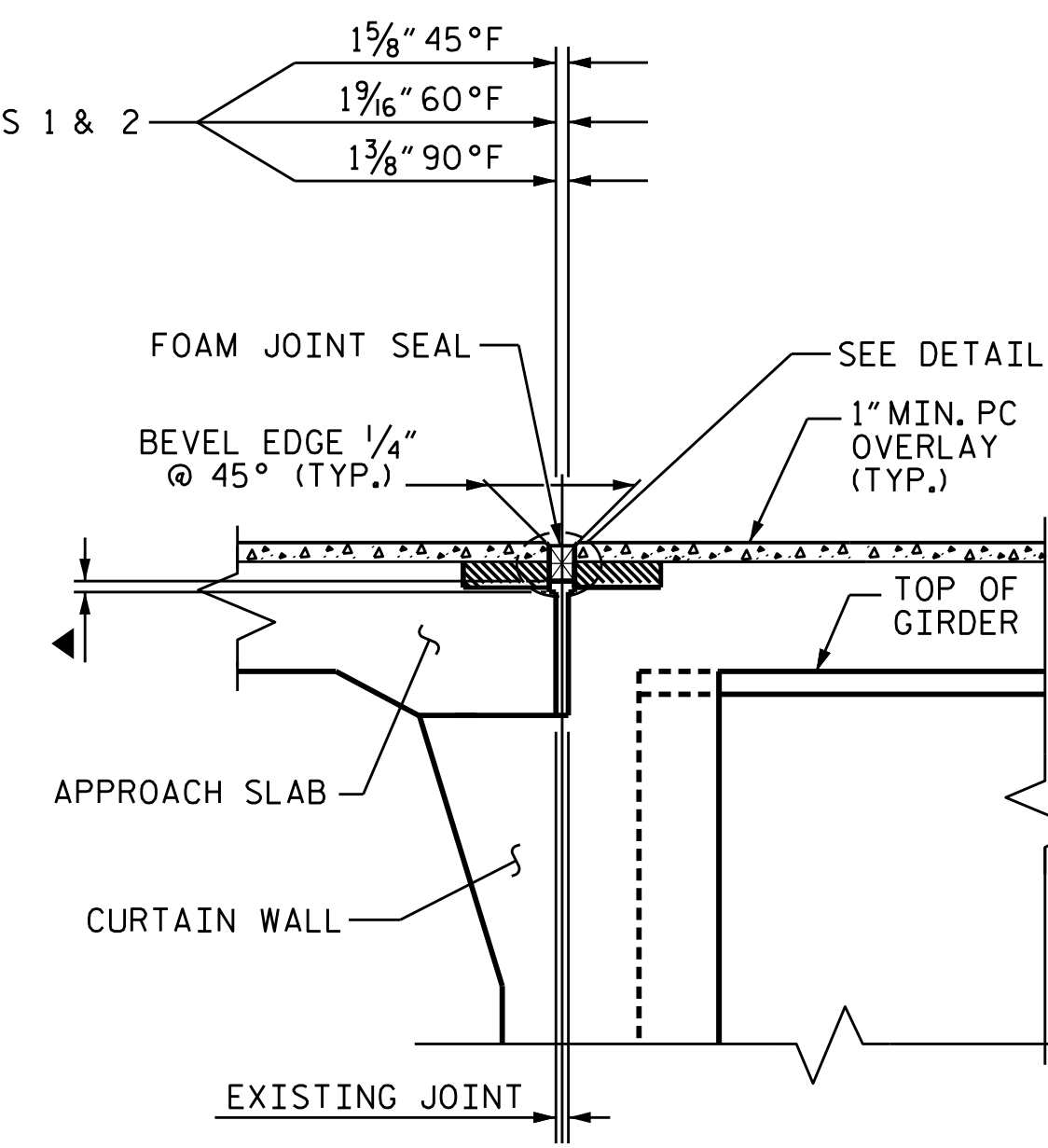

PROPOSED FOAM JOINT SEAL

▲ SAW CUT SHALL BE 1" BELOW THE BOTTOM OF FOAM JOINT SEAL. SEE MANUFACTURER RECOMMENDATIONS

JOINT INSTALLATION SEQUENCE AT END BENTS

SECTION A-A

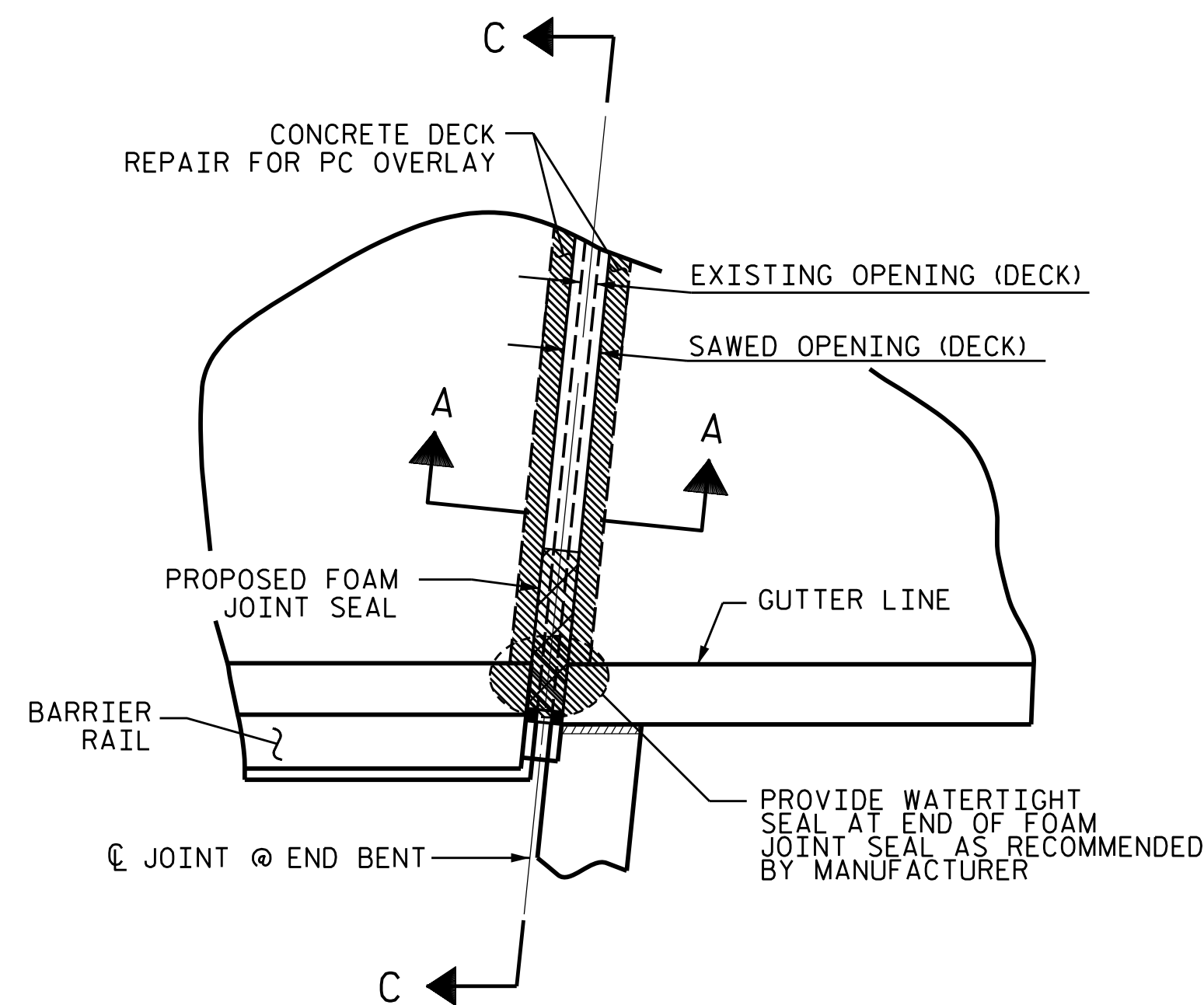

PLAN

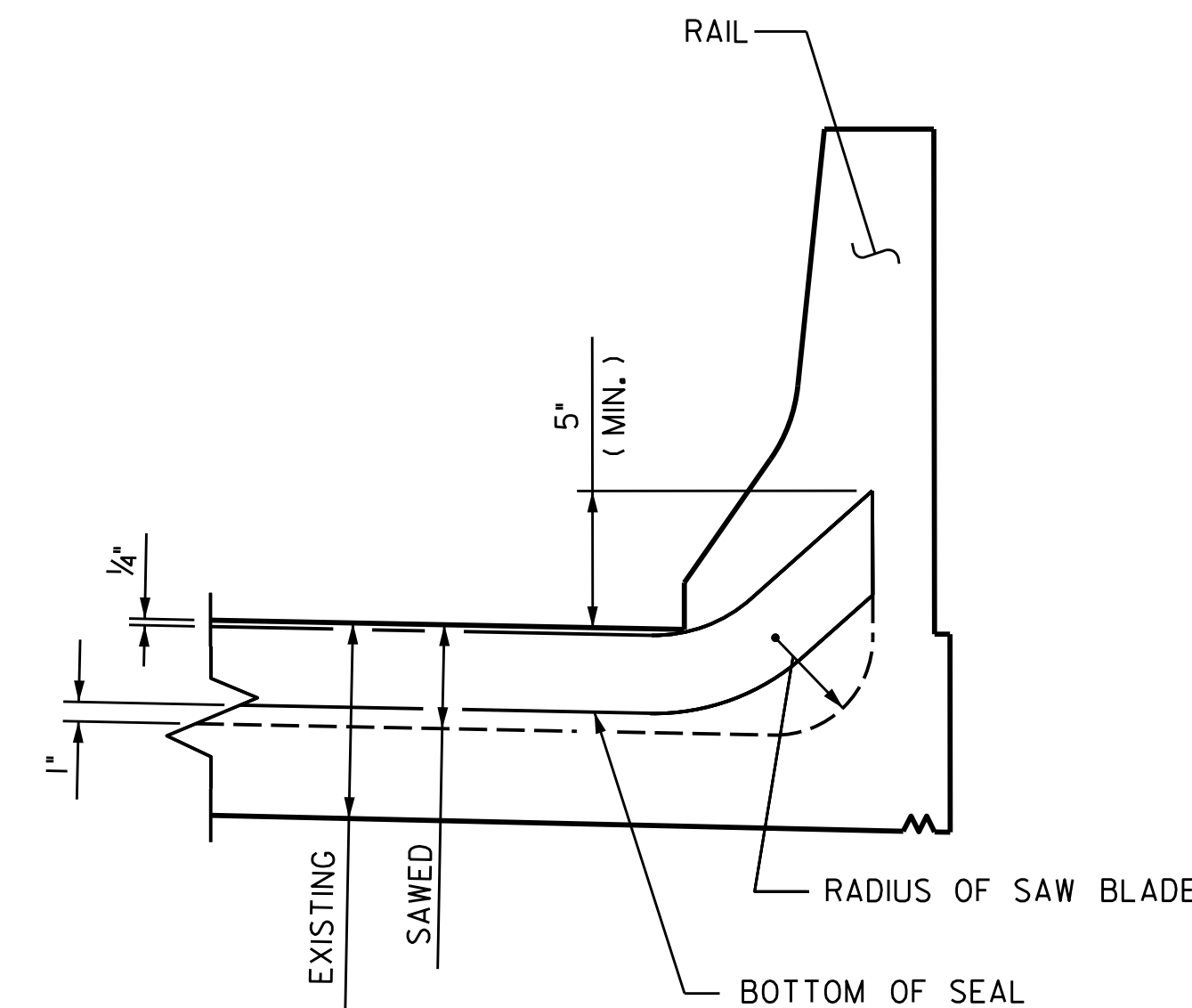

SECTION C-C

JOINT REPAIR QUANTITY TABLE		
	ESTIMATE	ACTUAL
FOAM JOINT SEAL FOR PRESERVATION		
END BENT 1	59.5 LF	
END BENT 2	59.3 LF	
TOTAL	118.8 LF	

PROJECT NO. I-5950
DAVIDSON COUNTY
 BRIDGE NO. 280152

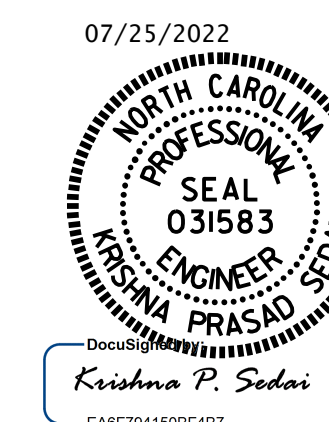

STATE OF NORTH CAROLINA
 DEPARTMENT OF TRANSPORTATION
 RALEIGH

JOINT DETAILS

DRAWN BY: M. G. SHAIKH DATE: 10/2020
 CHECKED BY: E. BAYISSA DATE: 03/2022

7/25/2022 SANDP331-I-5950\Final Plans\405_009_I5950_SMU.JT_S05_280152.dgn ksedai

DOCUMENT NOT CONSIDERED FINAL UNLESS ALL SIGNATURES COMPLETED

REVISIONS						SHEET NO.
NO.	BY:	DATE:	NO.	BY:	DATE:	
1			3			S5-05
2			4			TOTAL SHEETS 14