

PLAN - TOP OF CAP

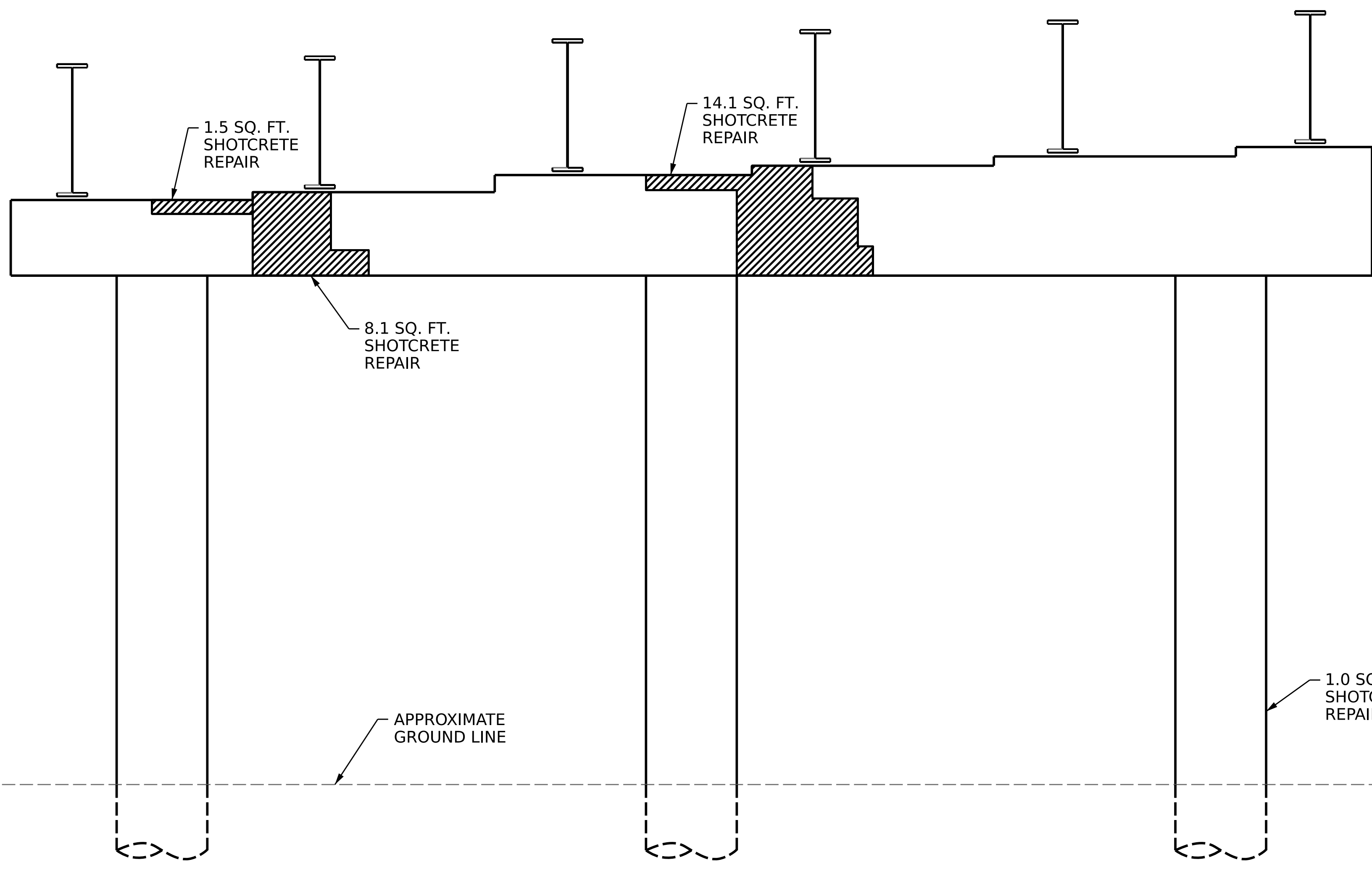

ELEVATION

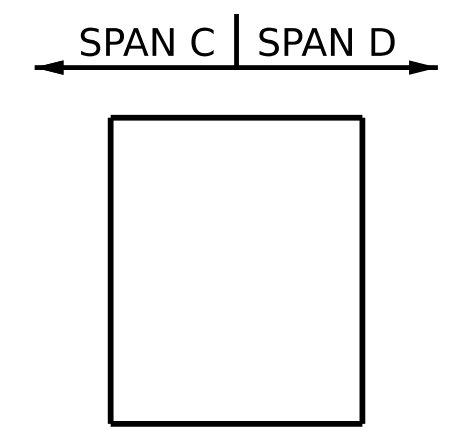

END VIEW

- SHOTCRETE REPAIR AREA
- CONCRETE REPAIR AREA
- EPOXY RESIN INJECTION

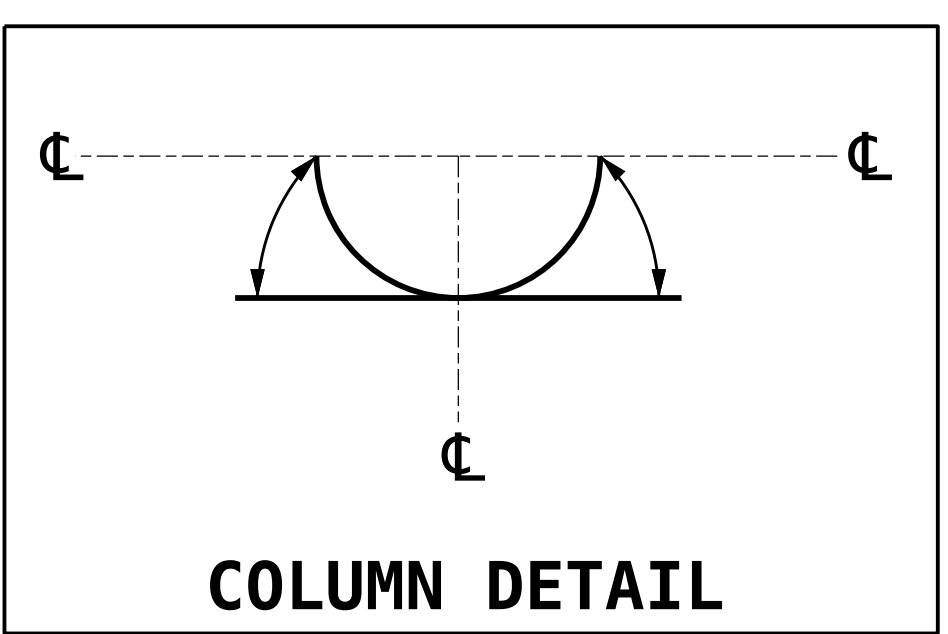

COLUMN DETAIL

AS-BUILT REPAIR QUANTITY TABLE				
BENT 3 SPAN C FACE	QUANTITIES			
	ESTIMATE		ACTUAL	
SHOTCRETE REPAIRS	AREA SF	VOLUME CF	AREA SF	VOLUME CF
CAP	23.7	11.9		
COLUMN	1.0	0.5		
CONCRETE REPAIRS	AREA SF	VOLUME CF	AREA SF	VOLUME CF
CAP	5.4	2.7		
COLUMN	0	0		
EPOXY RESIN INJECTION		LINEAR FT		LINEAR FT
CAP		0		
COLUMN		0		
EPOXY COATING		AREA SF		AREA SF
CAP		141.0		

VALUES IN CHART REPRESENT ESTIMATED REPAIR TOTALS AFTER REMOVAL OF UNSOUND CONCRETE, MIN. OF 1" BEHIND REBAR AND MIN. 2" CLEAR TO SAWCUT. SEE "TYPICAL CAP AND COLUMN REPAIR DETAILS" SHEET.

NOTES

REPAIR LOCATIONS AND ESTIMATE OF QUANTITIES ARE GIVEN BASED ON THE BEST INFORMATION AVAILABLE. IF ADDITIONAL REPAIRS NOT SHOWN ON THE DRAWINGS ARE DEEMED NECESSARY BY THE ENGINEER, THE ENGINEER SHALL NOTE ON THE DRAWINGS THE APPROXIMATE LOCATION AND DESCRIPTION OF THE REPAIRS AND ENTER THE ACTUAL QUANTITIES INTO THE AS-BUILT REPAIR QUANTITY TABLE.

CLEAN AND REMOVE DEBRIS FROM THE TOP OF THE CAP AND APPLY EPOXY PROTECTIVE COATING. EPOXY COATING SHALL BE APPLIED TO THE TOP SURFACE OF THE CAP. THE CONTRACTOR SHALL NOT COAT THE AREA OF THE CAP BENEATH THE MASONRY PLATES. FOR EPOXY COATING, SEE SPECIAL PROVISIONS.

SHOTCRETE REPAIRS MAYBE SUBSTITUTED IN LIEU OF CONCRETE REPAIRS WITH THE APPROVAL OF THE ENGINEER.

FOR CAP AND COLUMN REPAIR DETAILS, SEE "TYPICAL CAP AND COLUMN REPAIR DETAILS" SHEET.

FOR SHOTCRETE REPAIRS, SEE SPECIAL PROVISIONS.

FOR CONCRETE REPAIRS, SEE SPECIAL PROVISIONS.

FOR EPOXY RESIN INJECTION, SEE SPECIAL PROVISIONS.

PROJECT NO. **I-5950**
DAVIDSON COUNTY
 BRIDGE NO. **280146**

SHEET 1 OF 2

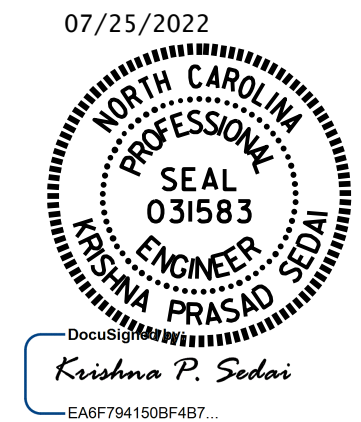

STATE OF NORTH CAROLINA
 DEPARTMENT OF TRANSPORTATION
 RALEIGH
SUBSTRUCTURE REPAIR
BENT 3
SPAN C FACE

REVISIONS						SHEET NO.
NO.	BY:	DATE:	NO.	BY:	DATE:	S3-13
1			3			TOTAL SHEETS
2			4			15

DOCUMENT NOT CONSIDERED FINAL UNLESS ALL SIGNATURES COMPLETED

DRAWN BY : E. BAYISSA DATE : 04/2022
 CHECKED BY : A. SORSENGINH DATE : 04/2022