

AS-BUILT REPAIR QUANTITY TABLE

DECK UNDERSIDE REPAIRS SPAN D	QUANTITIES			
	ESTIMATE		ACTUAL	
SHOTCRETE REPAIRS	AREA SF	VOLUME CF	AREA SF	VOLUME CF
UNDERSIDE OF DECK	0	0		
BENT DIAPHRAGM	0	0		
OVERHANG	1.3	0.4		

VALUES IN CHART REPRESENT ESTIMATED REPAIR TOTALS AFTER REMOVAL OF UNSOUND CONCRETE, MIN. OF 1" BEHIND REBAR AND MIN. 2" CLEAR TO SAWCUT. SEE REPAIR DETAILS.

NOTES

REPAIR LOCATIONS AND ESTIMATE OF QUANTITIES ARE GIVEN BASED ON THE BEST INFORMATION AVAILABLE. IF ADDITIONAL REPAIRS NOT SHOWN ON THE DRAWINGS ARE DEEMED NECESSARY BY THE ENGINEER, THE ENGINEER SHALL NOTE ON THE DRAWINGS THE APPROXIMATE LOCATION AND DESCRIPTION OF THE REPAIRS AND ENTER THE ACTUAL QUANTITIES INTO THE AS-BUILT REPAIR QUANTITY TABLE.

THE CONTRACTOR SHALL SAW CUT TO A NOMINAL DEPTH OF 1/2" BUT REINFORCING STEEL SHALL NOT BE DAMAGED.

CONTRACTOR SHALL REMOVE SURFACE CONCRETE TO VERIFY THAT SAWCUT DEPTH WILL NOT DAMAGE EXISTING REINFORCING STEEL.

SHOTCRETE REPAIRS MAYBE SUBSTITUTED IN LIEU OF CONCRETE REPAIRS WITH THE APPROVAL OF THE ENGINEER.

FOR UNDERSIDE DECK REPAIR, SEE "OVERHANG, DIAPHRAGM AND BRIDGE RAIL REPAIR DETAILS" SHEET.

FOR SHOTCRETE REPAIRS, SEE SPECIAL PROVISIONS.

FOR CONCRETE REPAIRS, SEE SPECIAL PROVISIONS.

PRIOR TO CLEANING AND PAINTING, REPLACE AND /OR TIGHTEN ANCHOR BOLT NUTS. SEE SPECIAL PROVISIONS.

-  SHOTCRETE REPAIR AREA
-  GIRDER NUMBER
-  PLATING REPAIR
-  TIGHTEN ANCHOR BOLT NUT

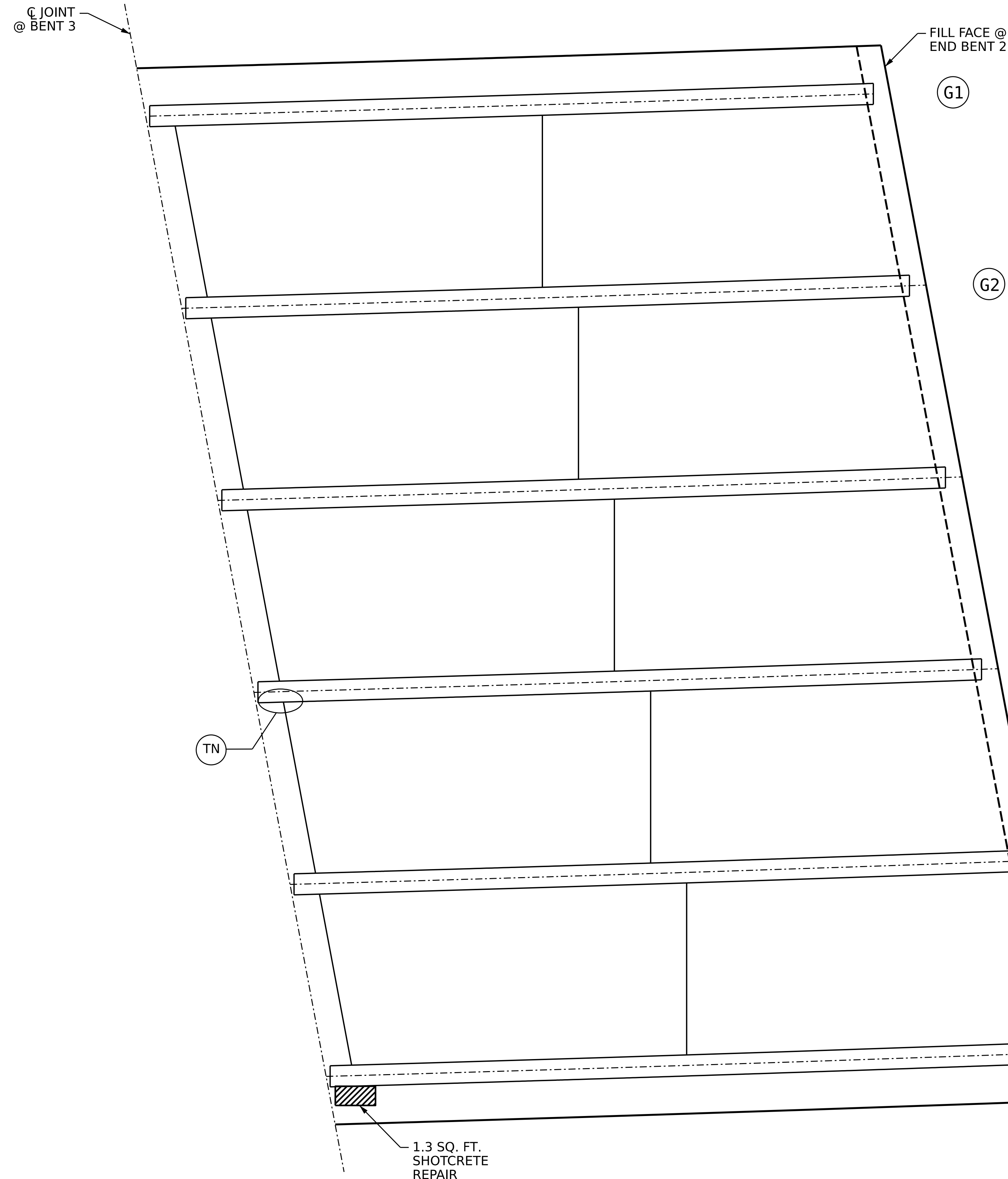

PLAN

PROJECT NO. **I-5950**
DAVIDSON COUNTY
 BRIDGE NO. **280146**

SHEET 4 OF 4

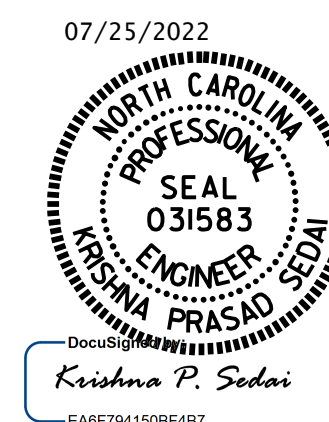

STATE OF NORTH CAROLINA
 DEPARTMENT OF TRANSPORTATION
 RALEIGH

DECK UNDERSIDE REPAIR SPAN D

REVISIONS						SHEET NO.
NO.	BY:	DATE:	NO.	BY:	DATE:	53-07
1			3			TOTAL SHEETS
2			4			15

DOCUMENT NOT CONSIDERED
 FINAL UNLESS ALL
 SIGNATURES COMPLETED

DRAWN BY : E. BAYISSA DATE : 04/2022
 CHECKED BY : A. SORSENGINH DATE : 05/2022