

PLAN - TOP OF CAP

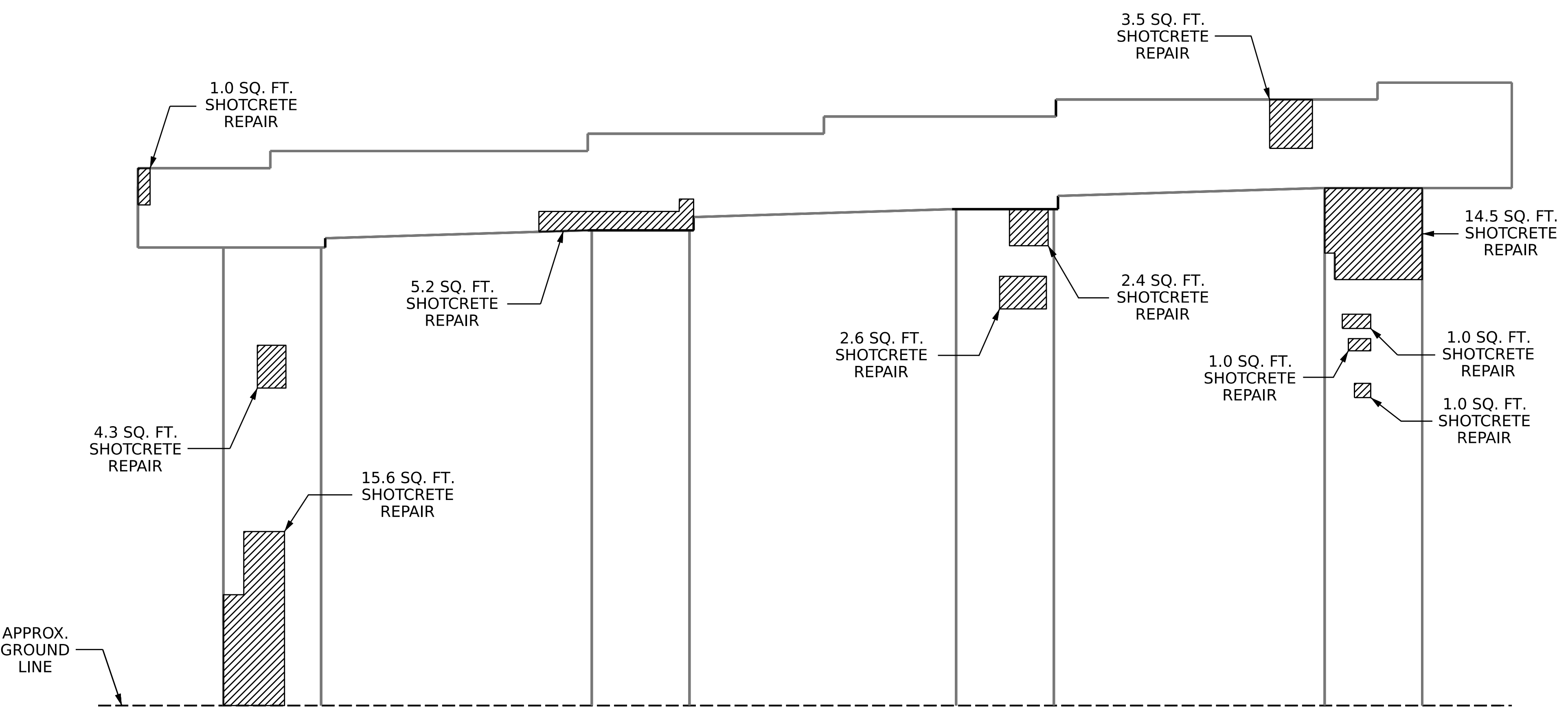

SPAN A VIEW - ELEVATION

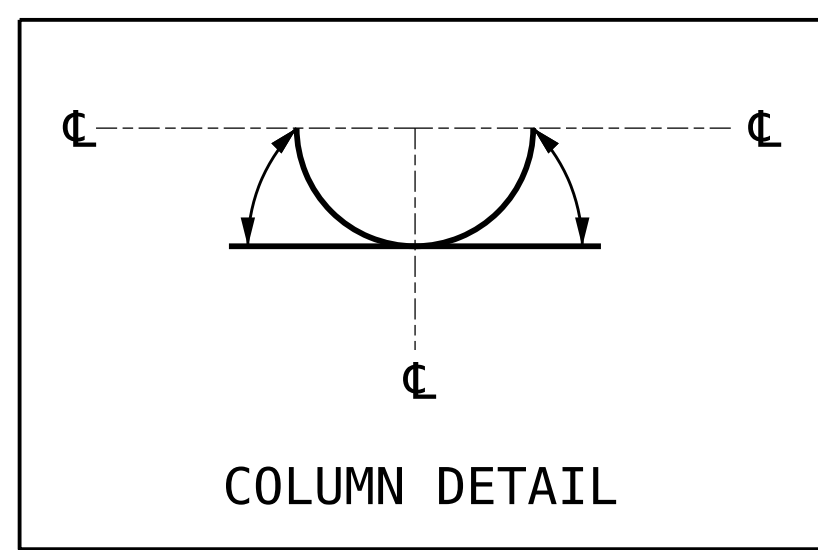

AS-BUILT REPAIR QUANTITY TABLE				
BENT 1 (A FACE)	QUANTITIES			
	ESTIMATE		ACTUAL	
SHOTCRETE REPAIRS	AREA SF	VOLUME CF	AREA SF	VOLUME CF
CAP	9.7	4.9		
COLUMN	42.4	21.2		
CONCRETE REPAIRS	AREA SF	VOLUME CF	AREA SF	VOLUME CF
CAP	5.9	3.0		
EPOXY RESIN INJECTION		LN. FT.		LN. FT.
CAP		0.0		
COLUMN		0.0		
EPOXY COATING		SQ. FT.		SQ. FT.
TOP OF BENT CAP		228.0		

VALUES IN CHART REPRESENT ESTIMATED REPAIR TOTALS AFTER REMOVAL OF UNSOUND CONCRETE, MINIMUM OF 1" BEHIND REBAR AND MINIMUM OF 2" CLEARANCE TO SAWCUT. FOR REPAIR DETAILS, SEE "TYPICAL CAP AND COLUMN REPAIR DETAILS" SHEET.

NOTES

REPAIR LOCATIONS AND ESTIMATE OF QUANTITIES ARE BASED ON THE BEST INFORMATION AVAILABLE. IF ADDITIONAL REPAIRS NOT SHOWN ON THE DRAWINGS ARE DEEMED NECESSARY BY THE ENGINEER, THE ENGINEER WILL NOTE ON THE DRAWINGS THE APPROXIMATE LOCATIONS AND DESCRIPTION OF THE REPAIRS AND ENTER THE ACTUAL QUANTITIES INTO THE AS-BUILT REPAIR QUANTITY TABLE.

FOR SHOTCRETE REPAIRS, SEE SPECIAL PROVISIONS.
FOR CONCRETE REPAIRS, SEE SPECIAL PROVISIONS.
FOR EPOXY RESIN INJECTION, SEE SPECIAL PROVISIONS.

FOR CAP AND COLUMN REPAIR DETAILS, SEE "TYPICAL CAP AND COLUMN REPAIR DETAILS" SHEET.

SHOTCRETE REPAIRS MAY BE REPLACED WITH CONCRETE REPAIRS WITH THE APPROVAL OF THE ENGINEER.

CLEAN AND REMOVE DEBRIS FROM THE TOP OF THE CAP AND APPLY EPOXY PROTECTIVE COATING. EPOXY COATING SHALL BE APPLIED TO THE TOP SURFACE OF THE CAP. THE CONTRACTOR SHALL NOT COAT THE AREA OF THE CAP BENEATH THE MASONRY PLATES. FOR EPOXY COATING, SEE SPECIAL PROVISIONS.

- SHOTCRETE REPAIR AREA
- CONCRETE REPAIR AREA
- ERI - EPOXY RESIN INJECTION

PROJECT NO. **I-5950**
DAVIDSON COUNTY
BRIDGE NO. **280137**

SHEET 1 OF 2

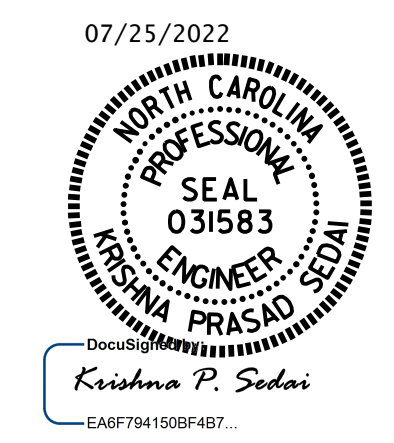

STATE OF NORTH CAROLINA
DEPARTMENT OF TRANSPORTATION
RALEIGH

**BENT 1
SPAN A FACE**

DRAWN BY : A. SORSENGINH DATE : 3/2022
CHECKED BY : E. BAYISSA DATE : 5/2022

NO.	BY:	DATE:	REVISIONS			SHEET NO.
			NO.	BY:	DATE:	
1			3			S2-15
2			4			TOTAL SHEETS 21

DOCUMENT NOT CONSIDERED FINAL UNLESS ALL SIGNATURES COMPLETED