

TIP NO. I-5950	SHEET NO. SIGN-2B
DocuSigned by: <i>Matthew V. Springer</i>	
APPROVED: 3/21/2019	
DATE: BC60F8E8B584403...	
SEAL	
	

STATE OF NORTH CAROLINA
DEPT. OF TRANSPORTATION
DIVISION OF HIGHWAYS
RALEIGH, N.C.

2-19

STATE OF NORTH CAROLINA
DEPT. OF TRANSPORTATION
DIVISION OF HIGHWAYS
RALEIGH, N.C.

2-19

ENGLISH DETAIL DRAWING FOR
TYPE 'B' SIGNS
WELDED STUD CONSTRUCTION

ENGLISH DETAIL DRAWING FOR
TYPE 'B' SIGNS
WELDED STUD CONSTRUCTION

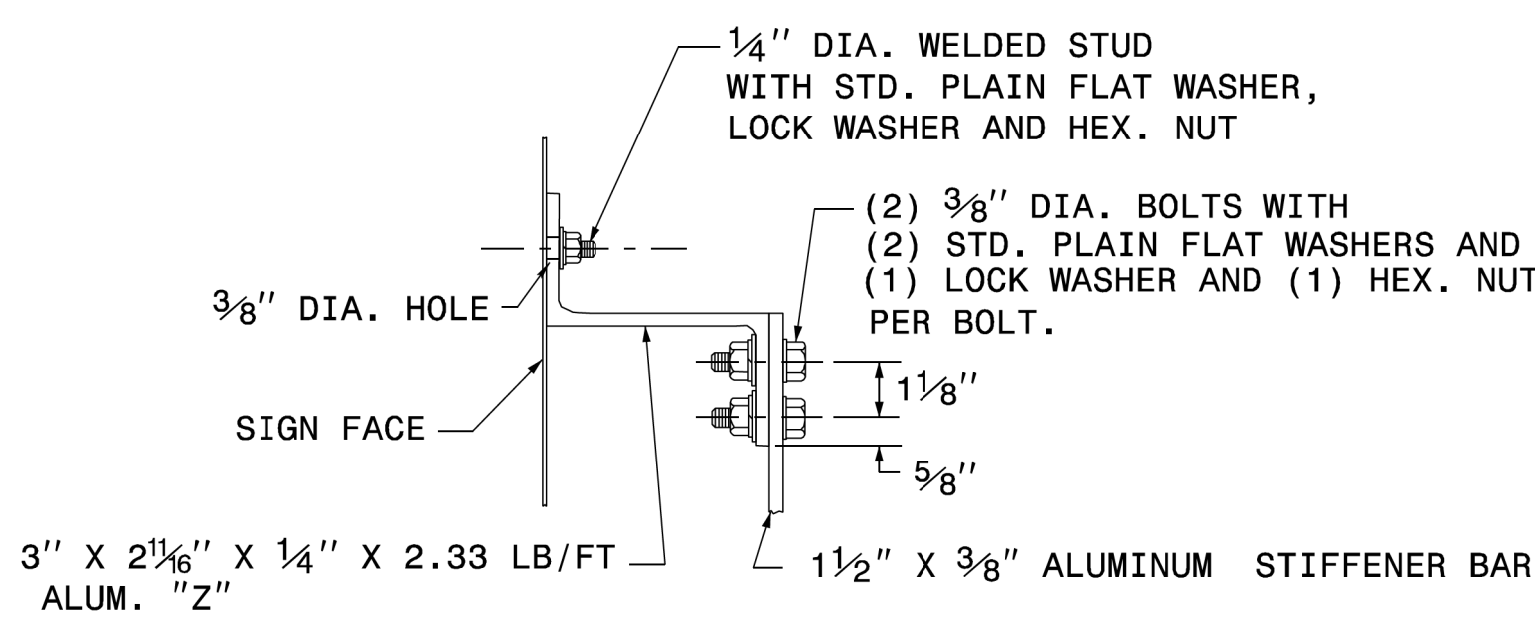
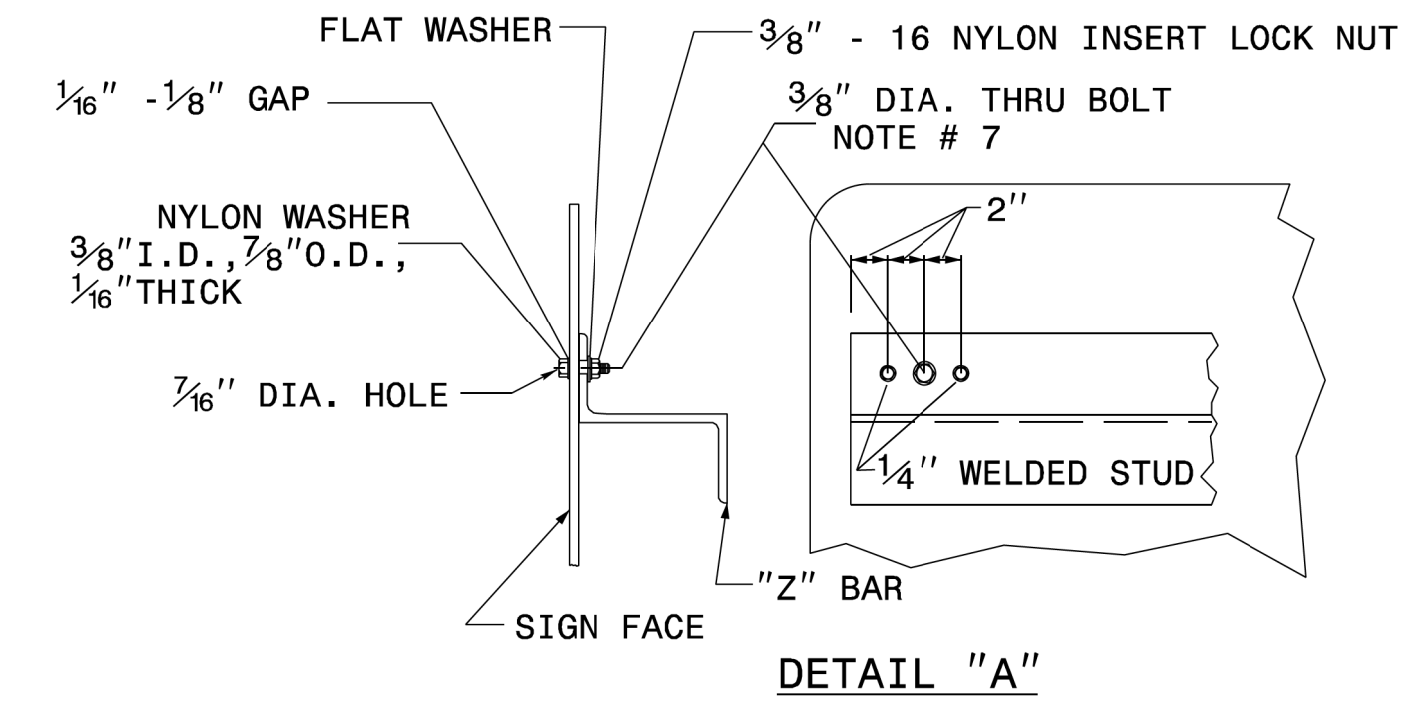

SECTION A-A
STIFFENER DETAIL

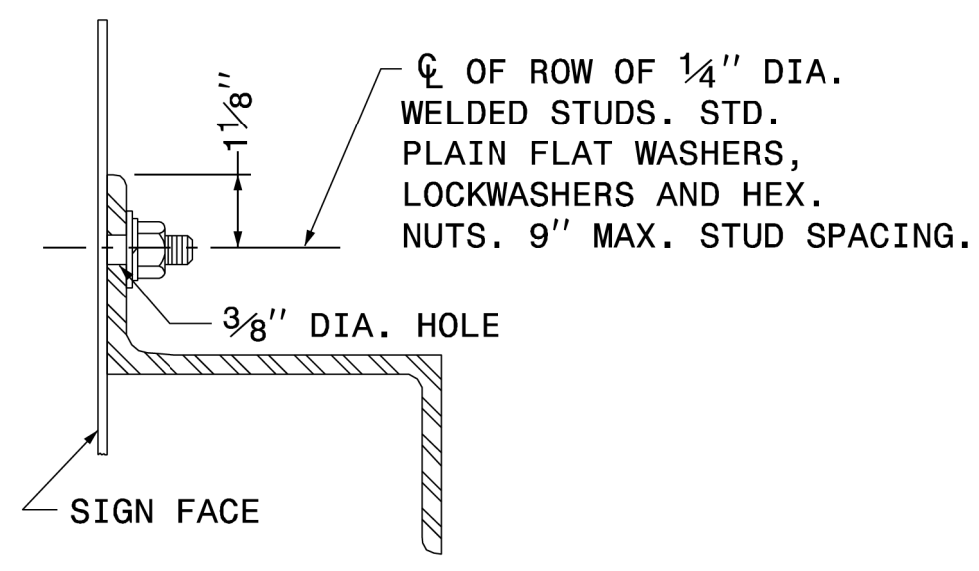

SECTION B-B

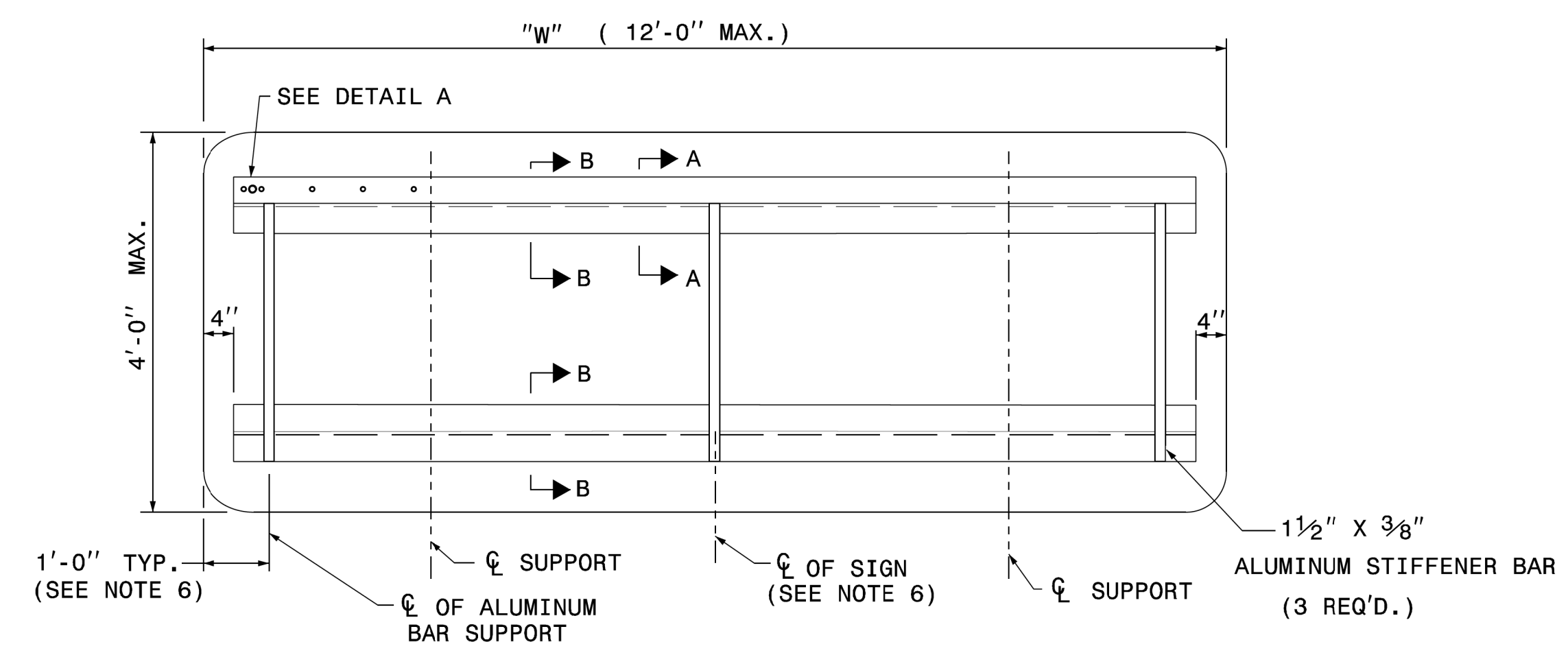

NOTES:

1. USE NUMBER AND SIZE OF SUPPORTS SHOWN ON SUPPORT CHART IN PROJECT PLAN SHEETS.
2. SEE NCDOT STANDARD SPECIFICATIONS FOR ROADS AND STRUCTURES FOR THE TYPE OF MATERIAL TO BE USED FOR SIGN PANELS, HANGER ASSEMBLIES AND SUPPORTS.
3. FURNISH ALL MOUNTING HARDWARE.
4. USE GALVANIZED STEEL FOR BACKING PLATES AND MOUNTING BOLTS.
5. THE VERTICAL DIMENSION BETWEEN PRIMARY AND SECONDARY SIGNS IS TWO (2) INCHES.
6. ADJUST STIFFENERS TO AVOID CONFLICT WITH SUPPORTS.
7. FABRICATE EACH SIGN WITH A 3/8" DIA. BOLT 4" FROM EACH END OF EACH "Z" BAR THRU SIGN PANEL AND "Z" BAR.
8. SEE ROADWAY STANDARD 901.70 FOR SUPPORT AND "Z" BAR SPACING.
9. SEE ROADWAY STANDARD 901.80 FOR DETAILS SHOWING SIGN MOUNTING TO SUPPORTS.
10. PLACE NYLON WASHER UNDER HEAD OF 3/8" THRU BOLT.
11. THRU BOLTS WILL HAVE A MINIMUM 1/16" TO MAXIMUM 1/8" GAP.

SHEET 1 OF 1
901D20

SHEET 1 OF 1
901D20

**REVISED SIGNING
ROADWAY STANDARD DRAWING**

03/20/19 S:\S&DU\Standards Group\Standards and Drawings\Drawings\2018 Standard Dwgs\Division 9 Final\0901D20-sgn_type b sign_2-19.dgn User:dstokes

3-14-19