

* IF REPAIR AREA EXCEEDS 30% OF THE CROSS-SECTIONAL AREA OR EXPOSES MORE THAN 4 MAIN COLUMN BARS THEN REPAIR LENGTH SHALL NOT EXCEED 10 FEET PER REPAIR SECTION. STAGE ADDITIONAL REPAIRS AS REQUIRED.

TYPICAL COLUMN BENT REPAIRS

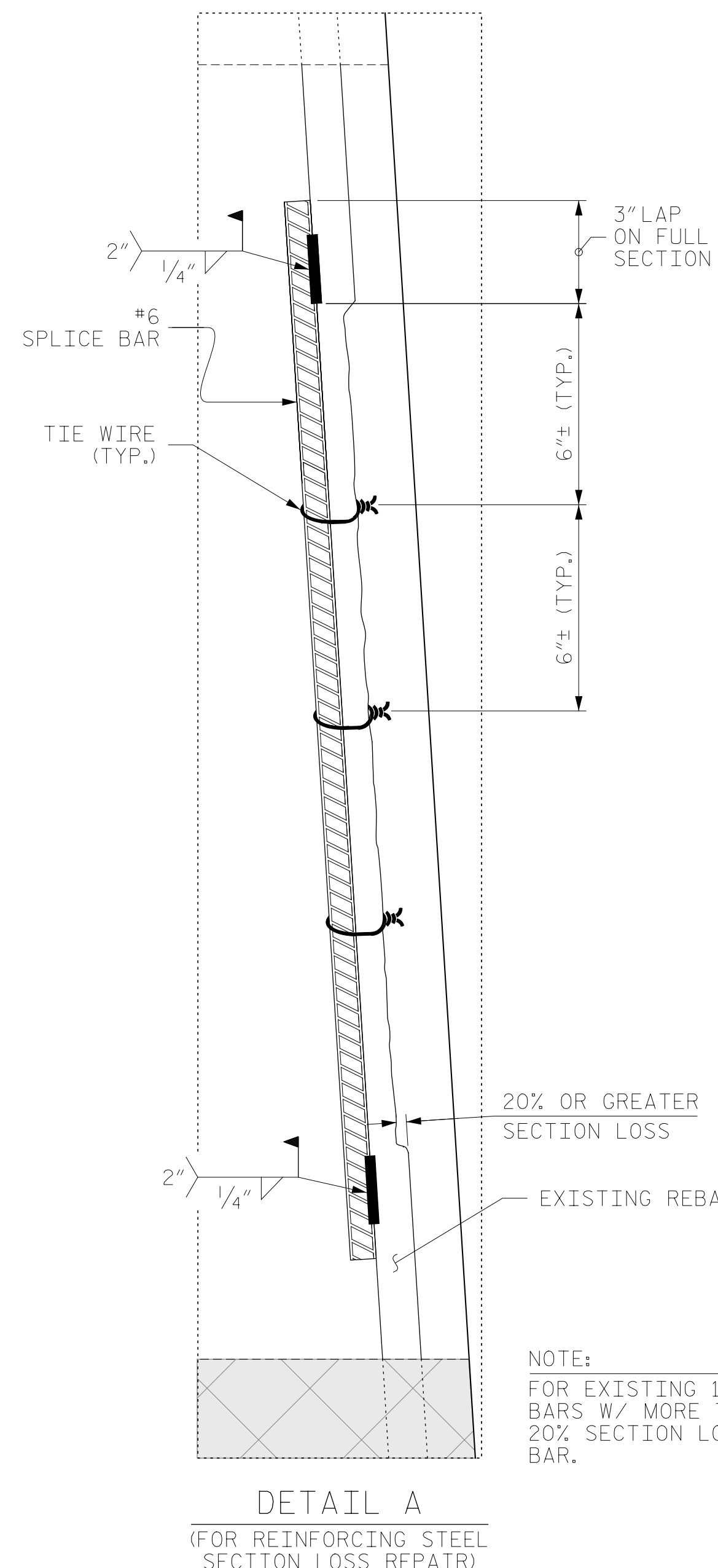

NOTES:

TYPICAL BENT CAP REPAIRS ARE SHOWN, REPAIR DETAILS SIMILAR FOR END BENT CAPS AND STRUTS.

THE CONTRACTOR SHALL REMOVE THE DETERIORATED CONCRETE IN ACCORDANCE WITH THE GUIDELINES SET IN THESE DRAWINGS, IN THE SPECIAL PROVISIONS AND THE STANDARD SPECIFICATIONS.

REMOVE UNSOUND CONCRETE TO THE EXTENT NECESSARY. MINIMUM OF 1" BEYOND ANY UNSOUND CONCRETE AND REBAR, AND A MINIMUM OF 2" CLEARANCE TO SAW CUT.

NO MORE THAN ONE-THIRD OF THE CAP OR COLUMN CIRCUMFERENCE SHALL BE REMOVED AT ONE TIME. SHOULD IT BECOME NECESSARY TO REMOVE MORE THAN 30% OF A CAP OR COLUMN CROSS SECTIONAL AREA, NOTIFY THE ENGINEER PRIOR TO PROCEEDING.

SIMULTANEOUS REMOVAL OF UNSOUND CONCRETE MAY BE PERMITTED ON MORE THAN ONE FACE OF A CAP AND/OR COLUMN, BUT NO MORE THAN ONE-THIRD OF THE CIRCUMFERENCE SHALL BE REMOVED AT ONE TIME. IF REMOVAL EXTENDS MORE THAN 1/2" BEHIND THE MAIN REINFORCING BARS, NOTIFY THE ENGINEER PRIOR TO PROCEEDING.

REINFORCING STEEL WHICH IS DETERMINED BY THE ENGINEER TO BE REPLACED, SHALL BE REMOVED TO A POINT WHERE IT IS SOUND. THE PATCH SHALL EXTEND A SUFFICIENT DISTANCE BEYOND THIS POINT TO DEVELOP THE SPLICE LENGTH SPECIFIED IN THE PLANS.

FOR ADHESIVELY ANCHORED ANCHOR BOLTS OR DOWELS, SEE STANDARD SPECIFICATIONS.

FOR SHOTCRETE REPAIRS, SEE SPECIAL PROVISIONS.

FOR EPOXY RESIN INJECTION (ERI), SEE SPECIAL PROVISIONS.

CLEAN ALL EXPOSED REINFORCING BARS IN ACCORDANCE WITH APPROPRIATE SPECIAL PROVISIONS, FOR BARS WITH MORE THAN 20% SECTION LOSS, SPLICE AND SECURELY TIE SUPPLEMENTAL REINFORCING BARS AS NEEDED.

- DEFECT AREA
- PILE FOOTING RESTORATION
- DEMOLITION LIMITS

PROJECT NO. HB-0017
DARE COUNTY
 BRIDGE NO. 270009

SHEET 1 OF 2

STATE OF NORTH CAROLINA
 DEPARTMENT OF TRANSPORTATION
 RALEIGH

TYPICAL CAP, COLUMN,
 & UNDERDECK REPAIR
 DETAILS

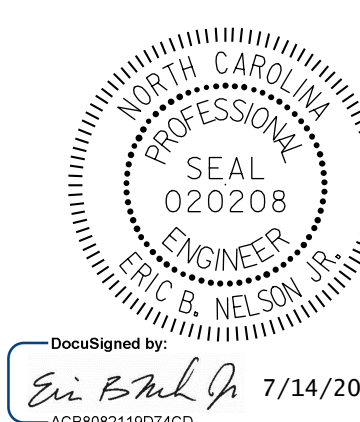

DocuSigned by:
 Eric B. Nelson, Jr. 7/14/2022
 ACB898211827ACD...



DOCUMENT NOT CONSIDERED
 FINAL UNLESS ALL
 SIGNATURES COMPLETED

REVISIONS						SHEET NO.
NO.	BY:	DATE:	NO.	BY:	DATE:	S-326
1			3			TOTAL SHEETS
2			4			355

DRAWN BY : M. SPENCER DATE : 03/2019
 CHECKED BY : R. NELSON DATE : 03/2019