

AS-BUILT REPAIR QUANTITY TABLE

BENT 291

CAP REPAIRS		ESTIMATE			
SHOTCRETE REPAIRS	- SF	- CF	SF	CF	
EPOXY RESIN INJECTION		- LF			LF
PILE REPAIRS		ESTIMATE			
PILE CONCRETE RESTORATION	6.3 SF	2.7 CF	SF	CF	
FRP PROTECTIVE SYSTEM AWL	143.0 SF				
FRP PROTECTIVE SYSTEM BWL	66.0 SF				

BENT 292

CAP REPAIRS		ESTIMATE			
SHOTCRETE REPAIRS	1.5 SF	0.8 CF	SF	CF	
EPOXY RESIN INJECTION		- LF			LF
PILE REPAIRS		ESTIMATE			
PILE CONCRETE RESTORATION	28.1 SF	12.1 CF	SF	CF	
FRP PROTECTIVE SYSTEM AWL	264.0 SF				
FRP PROTECTIVE SYSTEM BWL	99.0 SF				

FOR CAP REPAIRS: VALUES IN CHART REPRESENT ESTIMATED REPAIR TOTALS AFTER REMOVAL OF UNSOUND CONCRETE, MIN. OF 1" BEHIND REBAR AND MIN. 2" CL. TO SAWCUT. SEE REPAIR DETAILS.

NOTES:
REPAIR LOCATIONS AND ESTIMATE OF QUANTITIES ARE GIVEN WITH THE BEST INFORMATION AVAILABLE. IF ADDITIONAL REPAIRS NOT SHOWN ON THE DRAWINGS ARE DEEMED NECESSARY BY THE ENGINEER, THE CONTRACTOR SHALL NOTE ON THE DRAWINGS THE APPROXIMATE LOCATION AND DESCRIPTION OF THE REPAIRS AND ADJUST THE ACTUAL QUANTITIES ENTERED INTO THE REPAIR QUANTITY TABLE.

FOR SHOTCRETE REPAIRS, SEE SPECIAL PROVISIONS.
FOR CONCRETE REPAIR DETAILS, SEE "TYPICAL CAP, COLUMN & UNDERDECK REPAIR DETAILS" & "PILE CONCRETE RESTORATION DETAILS" SHEETS.
FOR PILE CONCRETE RESTORATION, SEE SPECIAL PROVISIONS.
FOR FRP PROTECTIVE SYSTEM, SEE SPECIAL PROVISIONS.
FOR FRP PROTECTIVE SYSTEM DETAILS AND UNDERWATER MORTAR REPAIRS, SEE "PILE FRP PROTECTIVE SYSTEM DETAILS" SHEET.

ESTIMATED PILE CRACK QTY. TABLE

BENT	PILE	DIRECTION							
		NW	W	SW	S	SE	E	NE	N
BENT 291	PILE 1	5	5	-	6	6	4	-	-
	PILE 2	-	3	-	-	5	3	-	-
	PILE 3	-	4	-	2	3	4	2	5
	PILE 4	6	4	-	4	3	3	3	6
BENT 292	PILE 1	3	3	-	2	2	4	-	4
	PILE 2	3	-	3	-	-	3	-	4
	PILE 3	-	-	4	3	-	3	7	3
	PILE 4	6	5	2	6	6	9	-	8
	PILE 5	6	7	5	4	6	8	3	-
	PILE 6	5	-	-	2	3	7	7	5

NOTE: FOR INFORMATION ON PILE CONDITION ONLY.

PROJECT NO. HB-0017
DARE COUNTY
BRIDGE NO. 270009

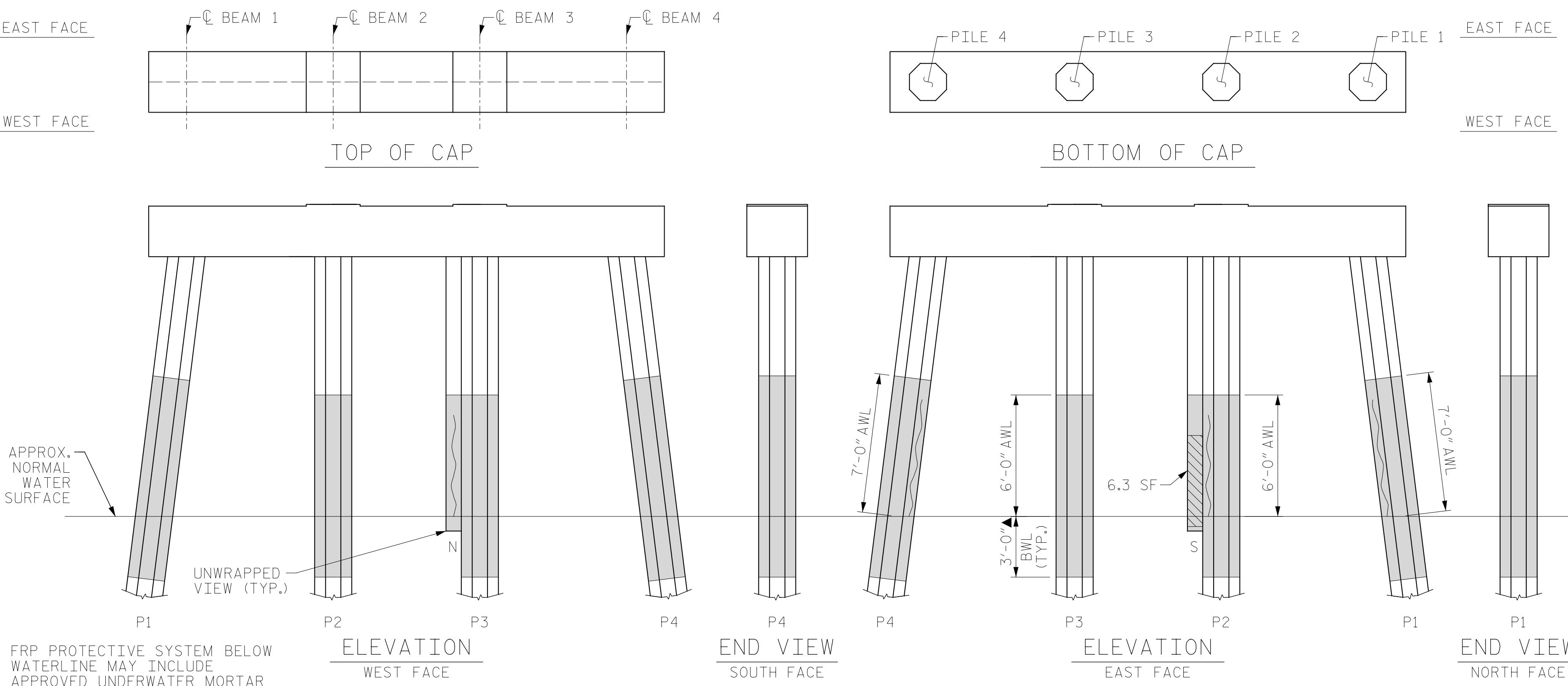
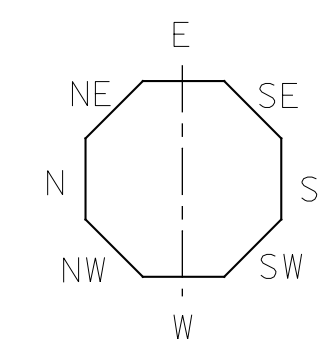

▲ FRP PROTECTIVE SYSTEM BELOW WATERLINE MAY INCLUDE APPROVED UNDERWATER MORTAR REPAIRS

BENT 291

(AWL = ABOVE WATERLINE) (BWL = BELOW WATERLINE)
(** QUANTITY INCLUDES ADJACENT REPAIRS)

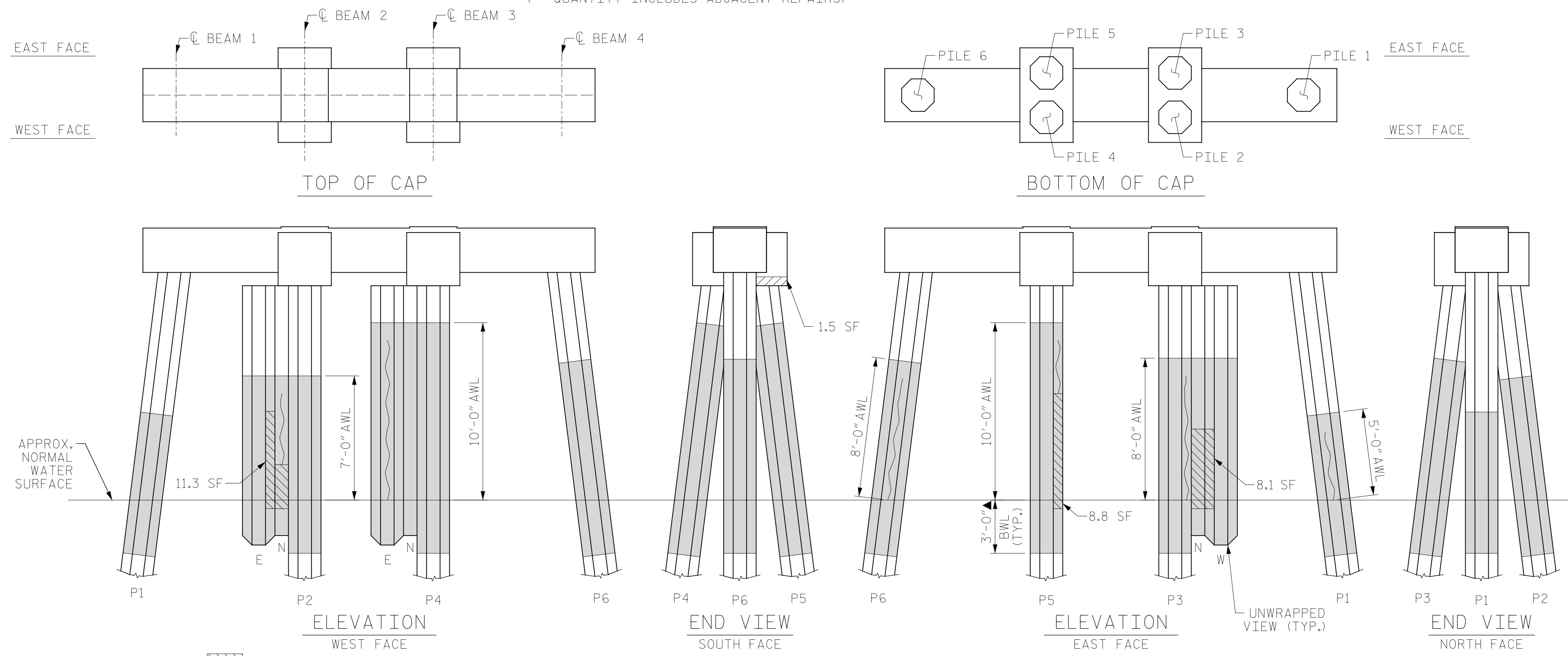

ERI - EPOXY RESIN INJECTION [Hatched] - PILE CONCRETE RESTORATION
[Gray] - FRP PROTECTIVE SYSTEM [Diagonal Lines] - SHOTCRETE REPAIRS

BENT 292

(AWL = ABOVE WATERLINE) (BWL = BELOW WATERLINE)
(** QUANTITY INCLUDES ADJACENT REPAIRS)

DRAWN BY: T. HARTLEY DATE: 2/2019
CHECKED BY: J. FARNHAM DATE: 4/2019



STATE OF NORTH CAROLINA
DEPARTMENT OF TRANSPORTATION
RALEIGH

BENT 291 & BENT 292

REVISIONS						SHEET NO.
NO.	BY:	DATE:	NO.	BY:	DATE:	S-315
1			3			
2			4			TOTAL SHEETS: 355

DOCUMENT NOT CONSIDERED FINAL UNLESS ALL SIGNATURES COMPLETED