

AS-BUILT REPAIR QUANTITY TABLE

BENT 259

CAP REPAIRS		ESTIMATE			
SHOTCRETE REPAIRS	17.2 SF	8.6 CF	SF	CF	
EPOXY RESIN INJECTION	- LF				LF
PILE REPAIRS		ESTIMATE			
PILE CONCRETE RESTORATION	49.3 SF	19.8 CF	SF	CF	
FRP PROTECTIVE SYSTEM AWL	197.1 SF				
FRP PROTECTIVE SYSTEM BWL	66.0 SF				

BENT 260

CAP REPAIRS		ESTIMATE			
SHOTCRETE REPAIRS	4.8 SF	2.4 CF	SF	CF	
EPOXY RESIN INJECTION	- LF				LF
PILE REPAIRS		ESTIMATE			
PILE CONCRETE RESTORATION	16.3 SF	6.9 CF	SF	CF	
FRP PROTECTIVE SYSTEM AWL	263.1 SF				
FRP PROTECTIVE SYSTEM BWL	99.0 SF				

FOR CAP REPAIRS: VALUES IN CHART REPRESENT ESTIMATED REPAIR TOTALS AFTER REMOVAL OF UNSOUND CONCRETE, MIN. OF 1" BEHIND REBAR AND MIN. 2" CL. TO SAWCUT. SEE REPAIR DETAILS.

NOTES:  
REPAIR LOCATIONS AND ESTIMATE OF QUANTITIES ARE GIVEN WITH THE BEST INFORMATION AVAILABLE. IF ADDITIONAL REPAIRS NOT SHOWN ON THE DRAWINGS ARE DEEMED NECESSARY BY THE ENGINEER, THE CONTRACTOR SHALL NOTE ON THE DRAWINGS THE APPROXIMATE LOCATION AND DESCRIPTION OF THE REPAIRS AND ADJUST THE ACTUAL QUANTITIES ENTERED INTO THE REPAIR QUANTITY TABLE.

FOR SHOTCRETE REPAIRS, SEE SPECIAL PROVISIONS.  
FOR CONCRETE REPAIR DETAILS, SEE "TYPICAL CAP, COLUMN & UNDERDECK REPAIR DETAILS" & "PILE CONCRETE RESTORATION DETAILS" SHEETS.  
FOR PILE CONCRETE RESTORATION, SEE SPECIAL PROVISIONS.  
FOR FRP PROTECTIVE SYSTEM, SEE SPECIAL PROVISIONS.  
FOR FRP PROTECTIVE SYSTEM DETAILS AND UNDERWATER MORTAR REPAIRS, SEE "PILE FRP PROTECTIVE SYSTEM DETAILS" SHEET.

ESTIMATED PILE CRACK QTY. TABLE

BENT	PILE	DIRECTION							
		NW	W	SW	S	SE	E	NE	N
BENT 259	PILE 1	-	4	-	6	6	-	-	-
	PILE 2	-	6	-	3	3	6	-	-
	PILE 3	-	6	3	-	-	4	6	-
	PILE 4	-	4	4	-	4	4	-	-
BENT 260	PILE 1	-	-	6	6	-	-	-	-
	PILE 2	2	-	4	5	-	4	6	5
	PILE 3	-	6	6	-	-	-	-	7
	PILE 4	3	-	-	3	3	5	5	-
	PILE 5	6	-	5	4	-	5	6	-
	PILE 6	13	4	5	-	5	6	13	-

NOTE: FOR INFORMATION ON PILE CONDITION ONLY.

PROJECT NO. HB-0017  
DARE COUNTY  
 BRIDGE NO. 270009

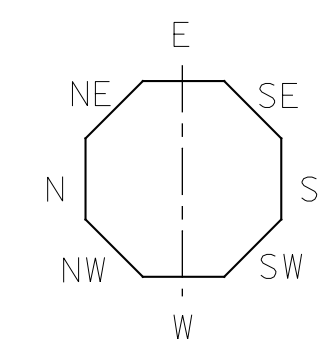

REVISIONS						SHEET NO.
NO.	BY:	DATE:	NO.	BY:	DATE:	S-299
1			3			TOTAL SHEETS
2			4			355

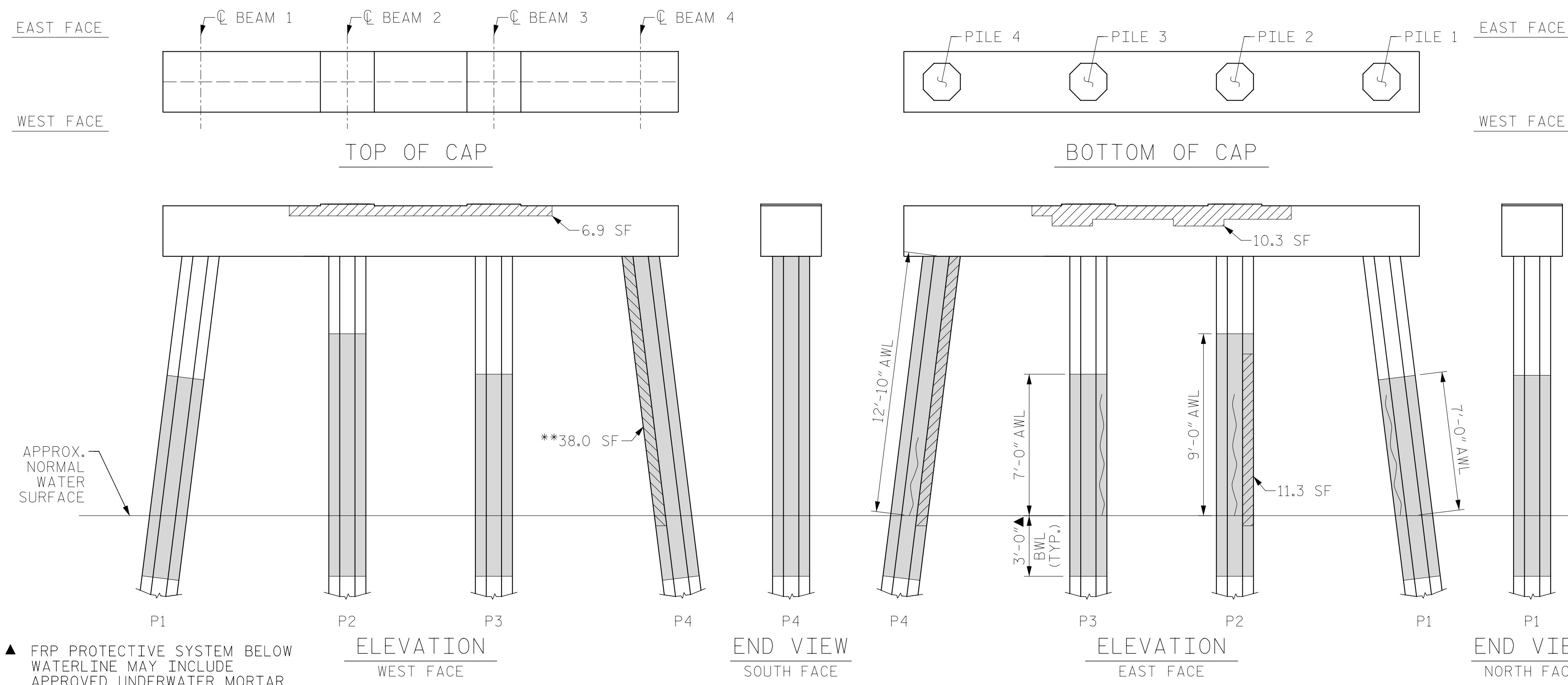

▲ FRP PROTECTIVE SYSTEM BELOW WATERLINE MAY INCLUDE APPROVED UNDERWATER MORTAR REPAIRS

BENT 259

(AWL = ABOVE WATERLINE) (BWL = BELOW WATERLINE)  
 (\*\* QUANTITY INCLUDES ADJACENT REPAIRS)

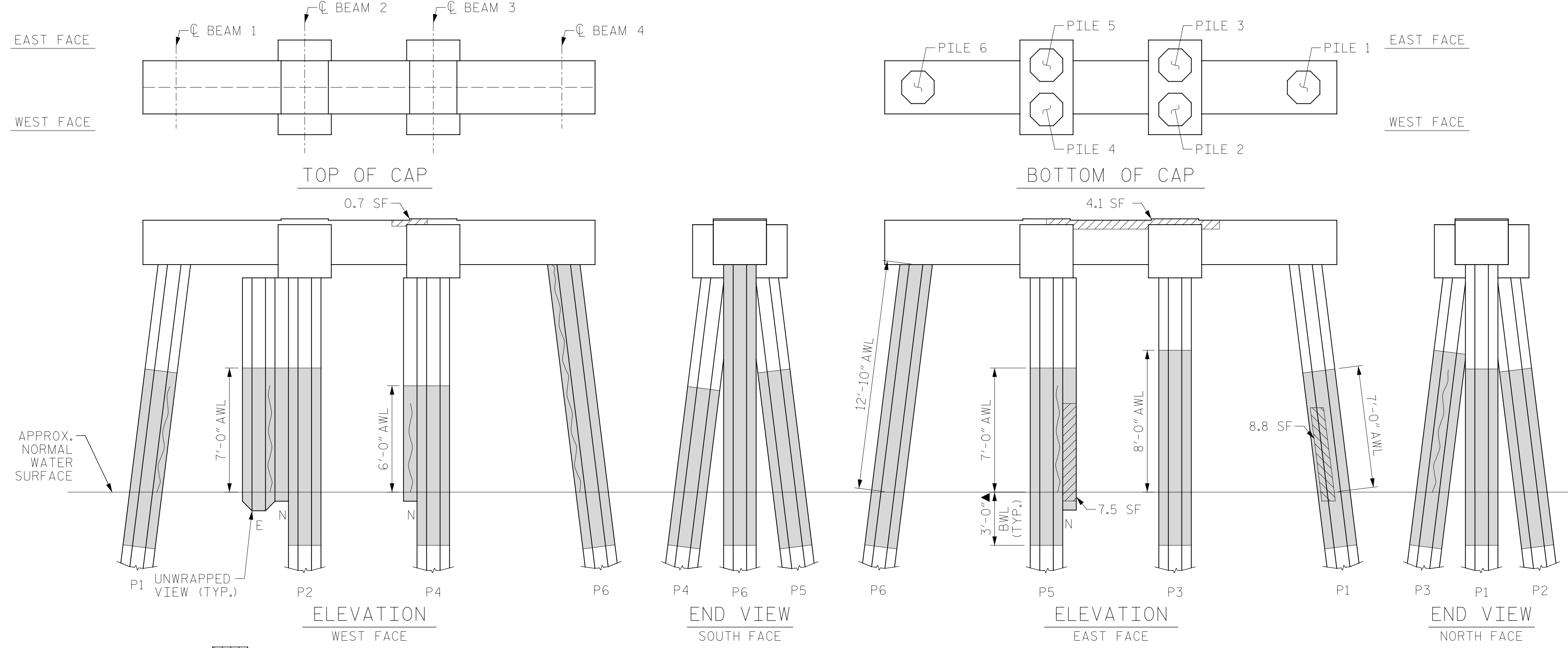

ERI - EPOXY RESIN INJECTION    [Hatched Box] - PILE CONCRETE RESTORATION  
 [Solid Box] - FRP PROTECTIVE SYSTEM    [Diagonal Lines Box] - SHOTCRETE REPAIRS

BENT 260

(AWL = ABOVE WATERLINE) (BWL = BELOW WATERLINE)  
 (\*\* QUANTITY INCLUDES ADJACENT REPAIRS)

DRAWN BY: T. HARTLEY    DATE: 2/2019  
 CHECKED BY: J. FARNHAM    DATE: 4/2019

