

AS-BUILT REPAIR QUANTITY TABLE

BENT 255

CAP REPAIRS				
SHOTCRETE REPAIRS	4.0 SF	2.0 CF	SF	CF
EPOXY RESIN INJECTION	- LF			LF
PILE REPAIRS				
PILE CONCRETE RESTORATION	86.4 SF	33.1 CF	SF	CF
FRP PROTECTIVE SYSTEM AWL	255.8 SF			
FRP PROTECTIVE SYSTEM BWL	66.0 SF			

BENT 256

CAP REPAIRS				
SHOTCRETE REPAIRS	- SF	- CF	SF	CF
EPOXY RESIN INJECTION	- LF			LF
PILE REPAIRS				
PILE CONCRETE RESTORATION	36.5 SF	15.0 CF	SF	CF
FRP PROTECTIVE SYSTEM AWL	202.6 SF			
FRP PROTECTIVE SYSTEM BWL	66.0 SF			

FOR CAP REPAIRS: VALUES IN CHART REPRESENT ESTIMATED REPAIR TOTALS AFTER REMOVAL OF UNSOUND CONCRETE, MIN. OF 1" BEHIND REBAR AND MIN. 2" CL. TO SAWCUT. SEE REPAIR DETAILS.

NOTES:

REPAIR LOCATIONS AND ESTIMATE OF QUANTITIES ARE GIVEN WITH THE BEST INFORMATION AVAILABLE. IF ADDITIONAL REPAIRS NOT SHOWN ON THE DRAWINGS ARE DEEMED NECESSARY BY THE ENGINEER, THE CONTRACTOR SHALL NOTE ON THE DRAWINGS THE APPROXIMATE LOCATION AND DESCRIPTION OF THE REPAIRS AND ADJUST THE ACTUAL QUANTITIES ENTERED INTO THE REPAIR QUANTITY TABLE.

FOR SHOTCRETE REPAIRS, SEE SPECIAL PROVISIONS.

FOR CONCRETE REPAIR DETAILS, SEE "TYPICAL CAP, COLUMN & UNDERDECK REPAIR DETAILS" & "PILE CONCRETE RESTORATION DETAILS" SHEETS.

FOR PILE CONCRETE RESTORATION, SEE SPECIAL PROVISIONS.

FOR FRP PROTECTIVE SYSTEM, SEE SPECIAL PROVISIONS.

FOR FRP PROTECTIVE SYSTEM DETAILS AND UNDERWATER MORTAR REPAIRS, SEE "PILE FRP PROTECTIVE SYSTEM DETAILS" SHEET.

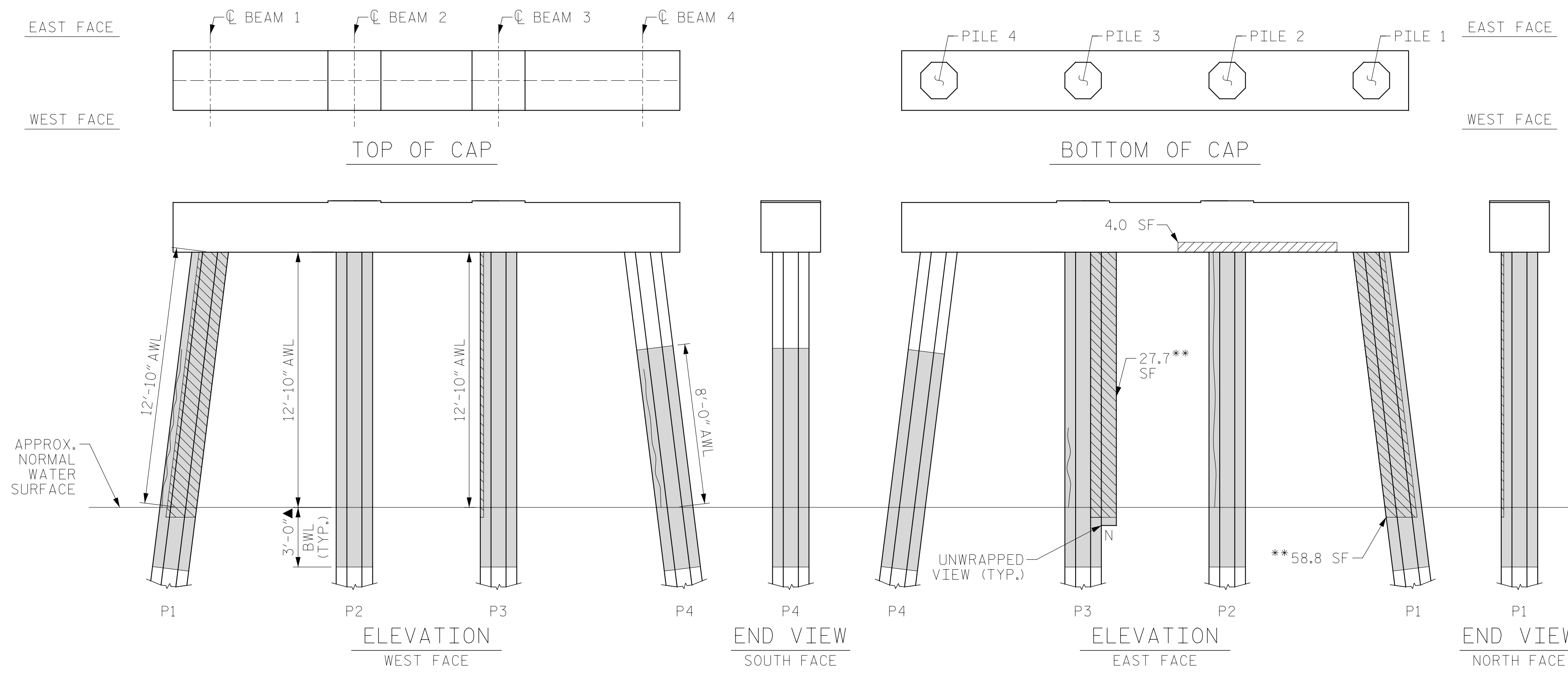

BENT 255

(AWL = ABOVE WATERLINE)
(BWL = BELOW WATERLINE)
(**QUANTITY INCLUDES ADJACENT REPAIRS)

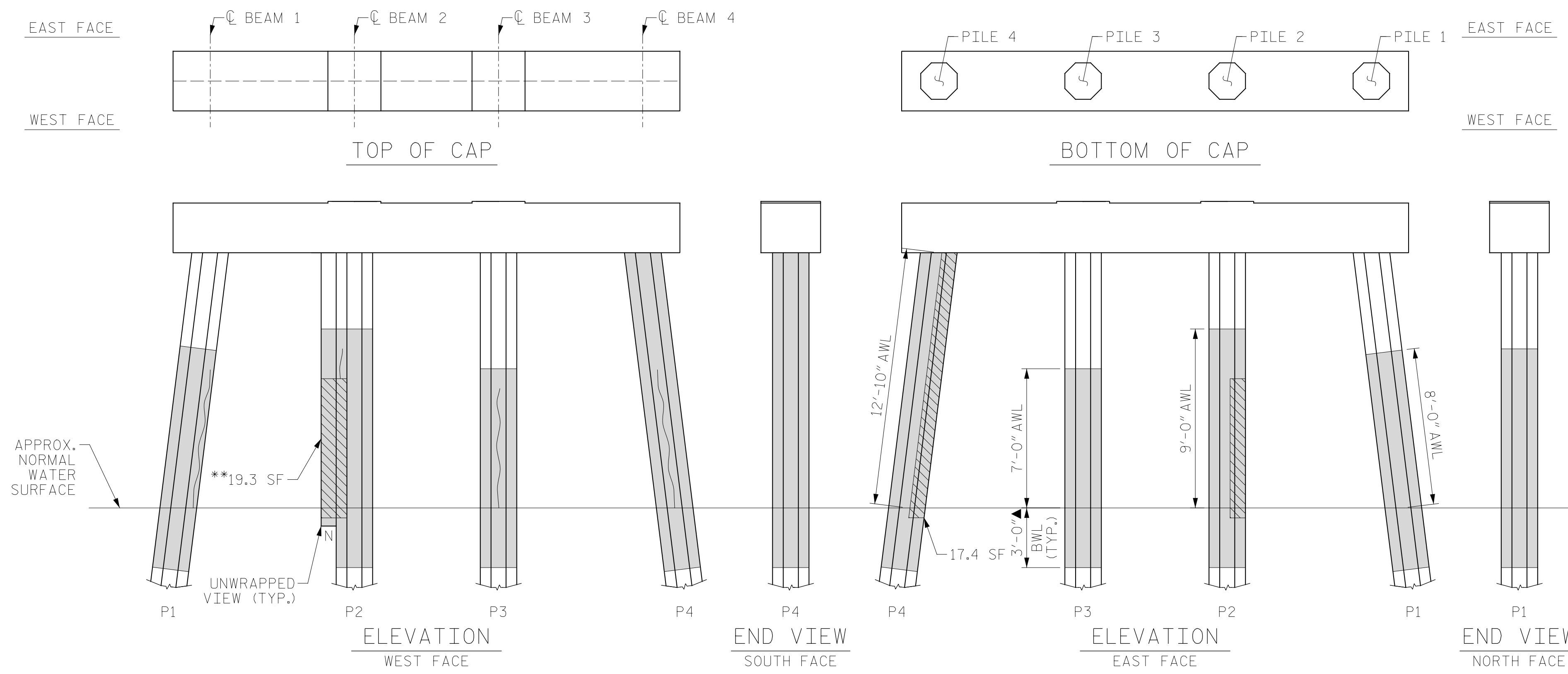

BENT 256

(AWL = ABOVE WATERLINE)
(BWL = BELOW WATERLINE)
(**QUANTITY INCLUDES ADJACENT REPAIRS)

	NW	W	SW	S	SE	E	NE	N
BENT 255	PILE 1	8	-	-	-	-	-	-
	PILE 2	-	-	3	13	3	-	4
	PILE 3	-	-	-	-	4	-	-
	PILE 4	7	5	3	-	-	6	-
BENT 256	PILE 1	6	6	7	6	6	6	-
	PILE 2	2	6	-	6	4	-	2
	PILE 3	-	6	6	2	4	5	-
	PILE 4	-	7	5	4	4	-	-

NOTE: FOR INFORMATION ON PILE CONDITION ONLY.

PROJECT NO. HB-0017
DARE COUNTY
BRIDGE NO. 270009

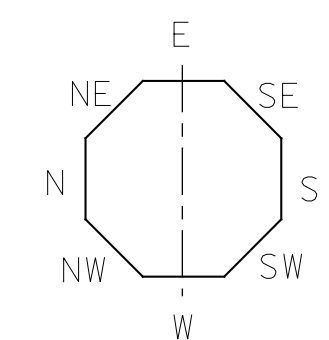

▲ FRP PROTECTIVE SYSTEM BELOW WATERLINE MAY INCLUDE APPROVED UNDERWATER MORTAR REPAIRS

- ERI - EPOXY RESIN INJECTION
- [Hatched Box] - FRP PROTECTIVE SYSTEM
- [Diagonal Lines Box] - PILE CONCRETE RESTORATION
- [Cross-hatched Box] - SHOTCRETE REPAIRS



STATE OF NORTH CAROLINA
DEPARTMENT OF TRANSPORTATION
RALEIGH

BENT 255 & BENT 256

DRAWN BY: T. HARTLEY DATE: 2/2019
CHECKED BY: J. FARNHAM DATE: 4/2019

GANNETT FLEMING
One Glenwood Avenue
Suite 900
Raleigh, NC 27603
(919) 420-7660
NC Lic. No. F-0270

DOCUMENT NOT CONSIDERED FINAL UNLESS ALL SIGNATURES COMPLETED

REVISIONS						SHEET NO.
NO.	BY:	DATE:	NO.	BY:	DATE:	TOTAL SHEETS
1			3			355
2			4			