

AS-BUILT REPAIR QUANTITY TABLE

BENT 253

CAP REPAIRS			
SHOTCRETE REPAIRS	3.5 SF	1.8 CF	SF CF
EPOXY RESIN INJECTION	- LF		LF
PILE REPAIRS			
PILE CONCRETE RESTORATION	38.0 SF	15.1 CF	SF CF
FRP PROTECTIVE SYSTEM AWL	153.1 SF		
FRP PROTECTIVE SYSTEM BWL	49.5 SF		

BENT 254

CAP REPAIRS			
SHOTCRETE REPAIRS	7.7 SF	3.9 CF	SF CF
EPOXY RESIN INJECTION	- LF		LF
PILE REPAIRS			
PILE CONCRETE RESTORATION	34.8 SF	14.0 CF	SF CF
FRP PROTECTIVE SYSTEM AWL	159.5 SF		
FRP PROTECTIVE SYSTEM BWL	66.0 SF		

FOR CAP REPAIRS: VALUES IN CHART REPRESENT ESTIMATED REPAIR TOTALS AFTER REMOVAL OF UNSOUND CONCRETE, MIN. OF 1" BEHIND REBAR AND MIN. 2" CL. TO SAWCUT. SEE REPAIR DETAILS.

NOTES:

REPAIR LOCATIONS AND ESTIMATE OF QUANTITIES ARE GIVEN WITH THE BEST INFORMATION AVAILABLE. IF ADDITIONAL REPAIRS NOT SHOWN ON THE DRAWINGS ARE DEEMED NECESSARY BY THE ENGINEER, THE CONTRACTOR SHALL NOTE ON THE DRAWINGS THE APPROXIMATE LOCATION AND DESCRIPTION OF THE REPAIRS AND ADJUST THE ACTUAL QUANTITIES ENTERED INTO THE REPAIR QUANTITY TABLE.

FOR SHOTCRETE REPAIRS, SEE SPECIAL PROVISIONS.

FOR CONCRETE REPAIR DETAILS, SEE "TYPICAL CAP, COLUMN & UNDERDECK REPAIR DETAILS" & "PILE CONCRETE RESTORATION DETAILS" SHEETS.

FOR PILE CONCRETE RESTORATION, SEE SPECIAL PROVISIONS.

FOR FRP PROTECTIVE SYSTEM, SEE SPECIAL PROVISIONS.

FOR FRP PROTECTIVE SYSTEM DETAILS AND UNDERWATER MORTAR REPAIRS, SEE "PILE FRP PROTECTIVE SYSTEM DETAILS" SHEET.

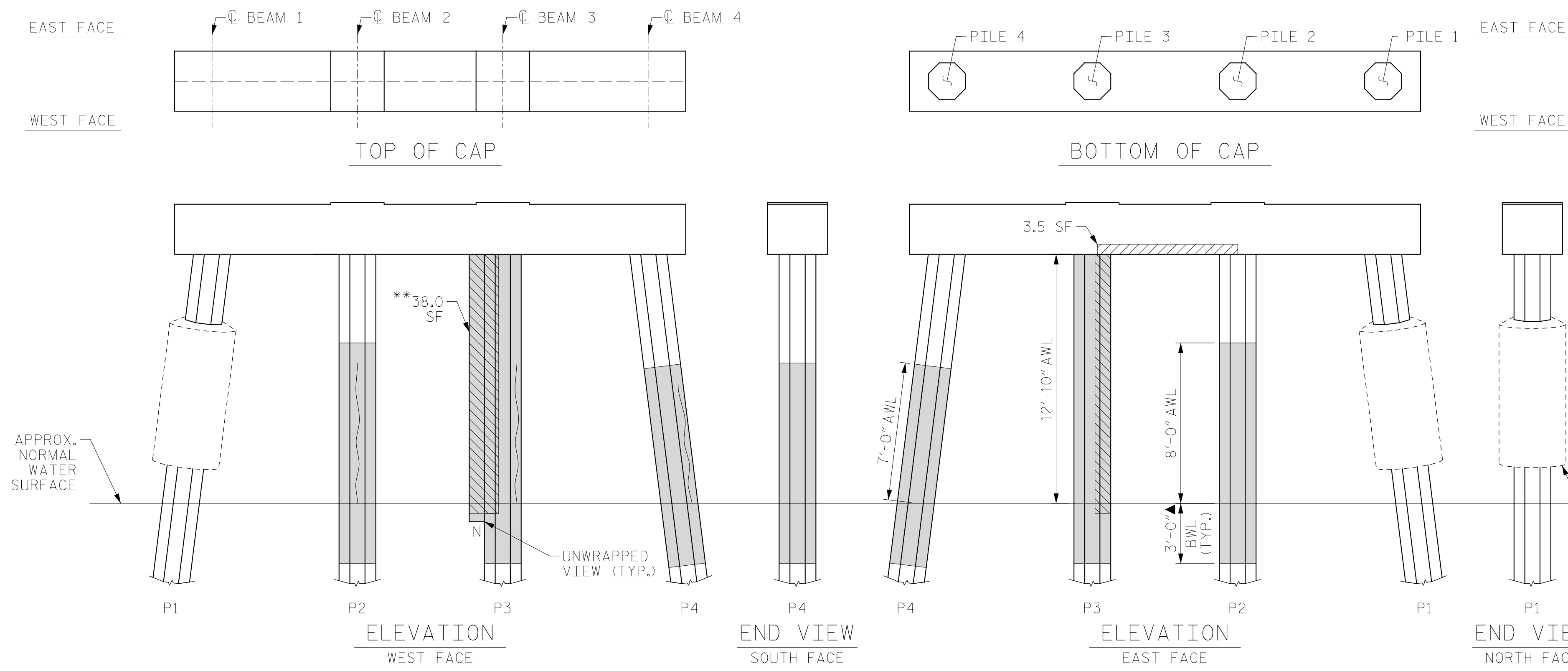

BENT 253

(AWL = ABOVE WATERLINE)  
(BWL = BELOW WATERLINE)  
(\*\*QUANTITY INCLUDES ADJACENT REPAIRS)

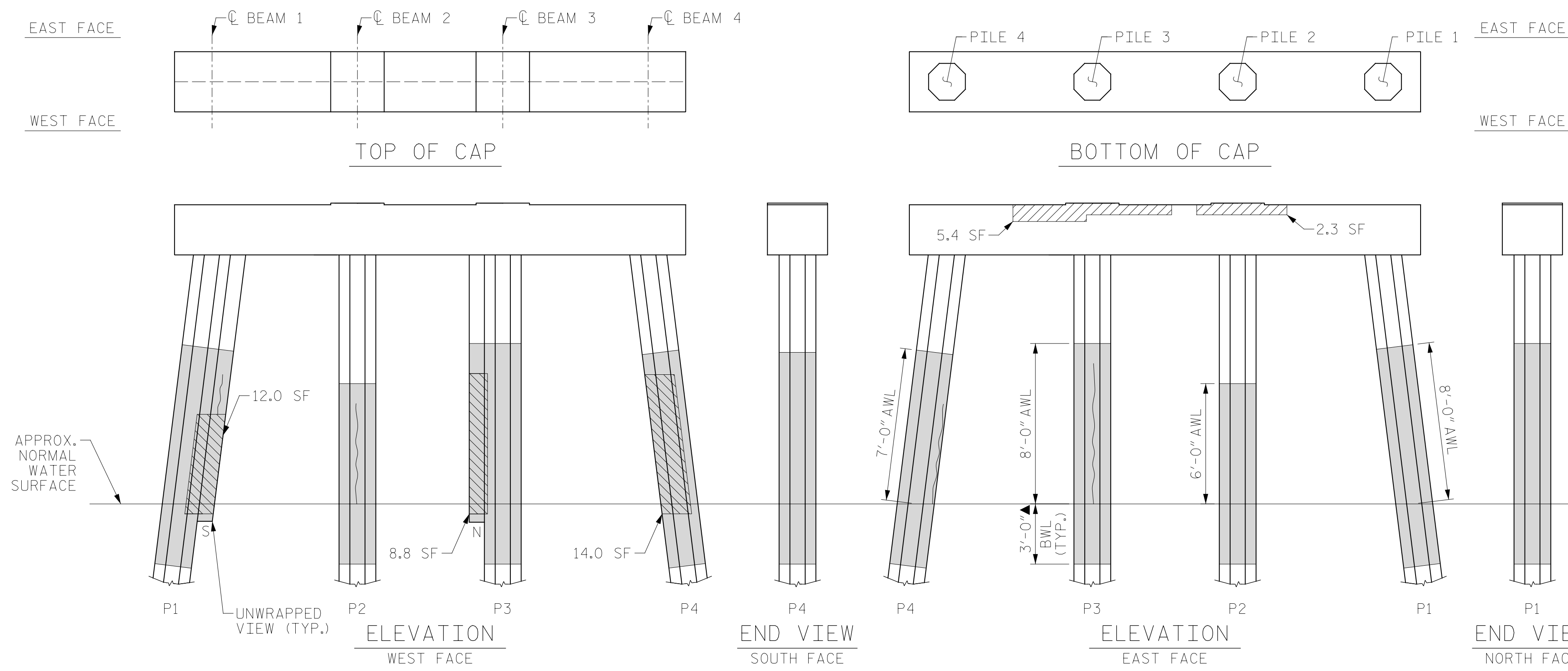

BENT 254

(AWL = ABOVE WATERLINE)  
(BWL = BELOW WATERLINE)  
(\*\*QUANTITY INCLUDES ADJACENT REPAIRS)

ESTIMATED PILE CRACK QTY. TABLE

BENT	PILE	DIRECTION							
		NW	W	SW	S	SE	E	NE	N
253	PILE 1	-	-	-	-	-	-	-	-
	PILE 2	4	7	-	4	6	-	-	-
	PILE 3	-	-	7	-	-	4	-	-
	PILE 4	-	4	5	3	3	6	-	6
254	PILE 1	4	4	-	2	4	4	5	3
	PILE 2	5	5	-	-	-	-	-	-
	PILE 3	6	6	-	-	3	7	-	-
	PILE 4	-	-	-	3	3	3	-	6

NOTE: FOR INFORMATION ON PILE CONDITION ONLY.

PROJECT NO. HB-0017  
DARE COUNTY  
BRIDGE NO. 270009

▲ FRP PROTECTIVE SYSTEM BELOW WATERLINE MAY INCLUDE APPROVED UNDERWATER MORTAR REPAIRS

- ERI - EPOXY RESIN INJECTION
- [Hatched Box] - FRP PROTECTIVE SYSTEM
- [Diagonal Lines] - PILE CONCRETE RESTORATION
- [Cross-hatched Box] - SHOTCRETE REPAIRS

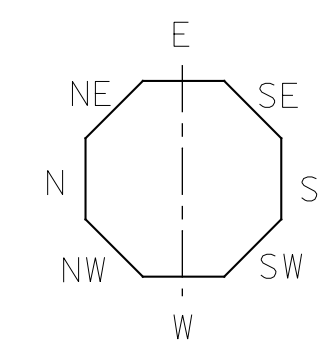

DocuSigned by:  
Eric B. Nelson, Jr.  
7/14/2022

STATE OF NORTH CAROLINA  
DEPARTMENT OF TRANSPORTATION  
RALEIGH

BENT 253 & BENT 254

DRAWN BY: T. HARTLEY DATE: 2/2019  
CHECKED BY: J. FARNHAM DATE: 4/2019



DOCUMENT NOT CONSIDERED FINAL UNLESS ALL SIGNATURES COMPLETED

REVISIONS						SHEET NO.
NO.	BY:	DATE:	NO.	BY:	DATE:	TOTAL SHEETS
1			3			355
2			4			