

AS-BUILT REPAIR QUANTITY TABLE

BENT 245

CAP REPAIRS			
SHOTCRETE REPAIRS	2.2 SF	1.1 CF	SF CF
EPOXY RESIN INJECTION	- LF		LF
PILE REPAIRS			
PILE CONCRETE RESTORATION	23.7 SF	10.1 SF	SF CF
FRP PROTECTIVE SYSTEM AWL	181.5 SF		
FRP PROTECTIVE SYSTEM BWL	66.0 SF		

BENT 246

CAP REPAIRS			
SHOTCRETE REPAIRS	13.3 SF	6.7 CF	SF CF
EPOXY RESIN INJECTION	- LF		LF
PILE REPAIRS			
PILE CONCRETE RESTORATION	42.6 SF	17.3 CF	SF CF
FRP PROTECTIVE SYSTEM AWL	213.6 SF		
FRP PROTECTIVE SYSTEM BWL	66.0 SF		

FOR CAP REPAIRS: VALUES IN CHART REPRESENT ESTIMATED REPAIR TOTALS AFTER REMOVAL OF UNSOUND CONCRETE, MIN. OF 1" BEHIND REBAR AND MIN. 2" CL. TO SAWCUT. SEE REPAIR DETAILS.

NOTES:

REPAIR LOCATIONS AND ESTIMATE OF QUANTITIES ARE GIVEN WITH THE BEST INFORMATION AVAILABLE. IF ADDITIONAL REPAIRS NOT SHOWN ON THE DRAWINGS ARE DEEMED NECESSARY BY THE ENGINEER, THE CONTRACTOR SHALL NOTE ON THE DRAWINGS THE APPROXIMATE LOCATION AND DESCRIPTION OF THE REPAIRS AND ADJUST THE ACTUAL QUANTITIES ENTERED INTO THE REPAIR QUANTITY TABLE.

FOR SHOTCRETE REPAIRS, SEE SPECIAL PROVISIONS.

FOR CONCRETE REPAIR DETAILS, SEE "TYPICAL CAP, COLUMN & UNDERDECK REPAIR DETAILS" & "PILE CONCRETE RESTORATION DETAILS" SHEETS.

FOR PILE CONCRETE RESTORATION, SEE SPECIAL PROVISIONS.

FOR FRP PROTECTIVE SYSTEM, SEE SPECIAL PROVISIONS.

FOR FRP PROTECTIVE SYSTEM DETAILS AND UNDERWATER MORTAR REPAIRS, SEE "PILE FRP PROTECTIVE SYSTEM DETAILS" SHEET.

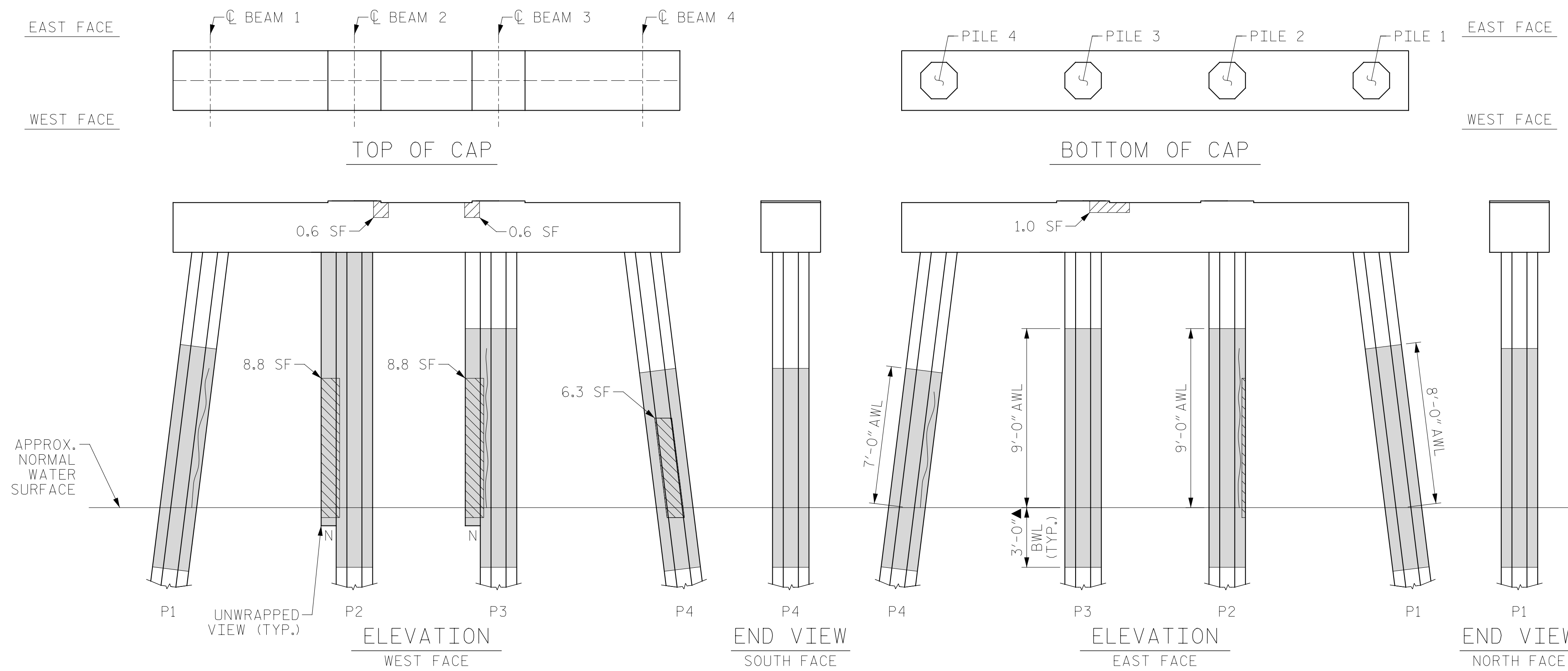

BENT 245

(AWL = ABOVE WATERLINE)  
(BWL = BELOW WATERLINE)  
(\*QUANTITY INCLUDES ADJACENT REPAIRS)

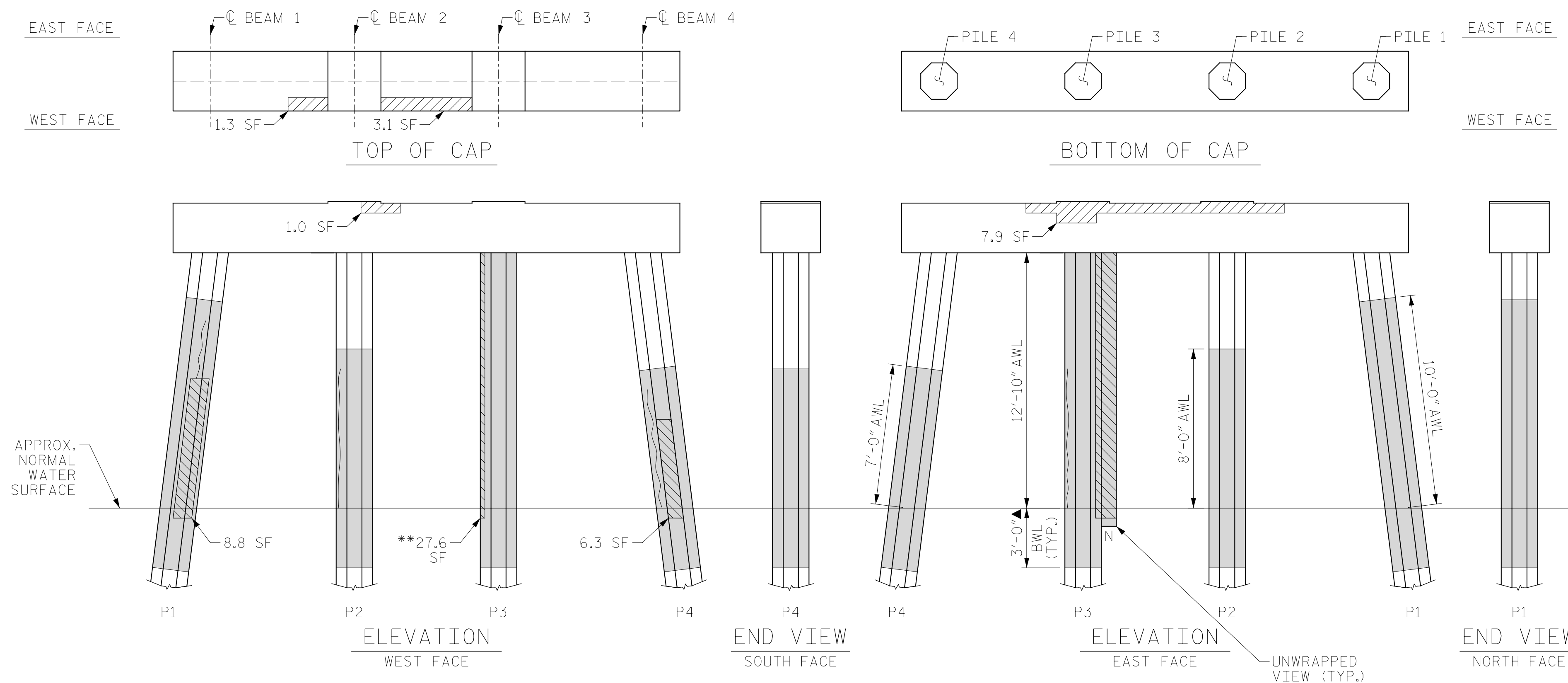

BENT 246

(AWL = ABOVE WATERLINE)  
(BWL = BELOW WATERLINE)  
(\*QUANTITY INCLUDES ADJACENT REPAIRS)

ESTIMATED PILE CRACK QTY. TABLE

BENT	PILE	DIRECTION							
		NW	W	SW	S	SE	E	NE	N
245	PILE 1	-	-	7	6	-	6	3	-
	PILE 2	7	5	5	-	-	5	8	-
	PILE 3	8	4	-	-	3	-	7	-
	PILE 4	-	-	5	3	3	-	6	5
246	PILE 1	-	3	3	-	3	-	-	-
	PILE 2	-	4	-	4	3	-	-	7
	PILE 3	13	-	-	7	7	-	-	-
	PILE 4	6	-	5	4	3	-	-	-

NOTE: FOR INFORMATION ON PILE CONDITION ONLY.

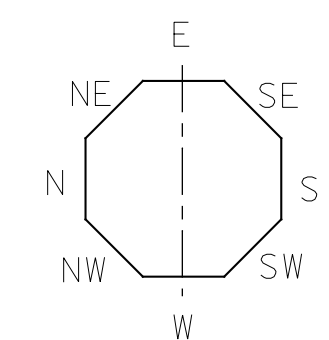

▲ FRP PROTECTIVE SYSTEM BELOW WATERLINE MAY INCLUDE APPROVED UNDERWATER MORTAR REPAIRS

- ERI - EPOXY RESIN INJECTION
- [Hatched Box] - FRP PROTECTIVE SYSTEM
- [Diagonal Lines] - PILE CONCRETE RESTORATION
- [Cross-hatched Box] - SHOTCRETE REPAIRS

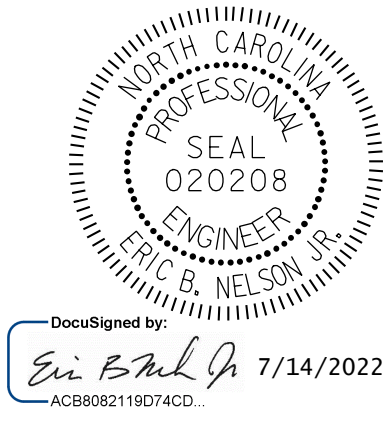

DocuSigned by:  
Eric B. Nelson, Jr.  
7/14/2022

PROJECT NO. HB-0017  
DARE COUNTY  
BRIDGE NO. 270009

STATE OF NORTH CAROLINA  
DEPARTMENT OF TRANSPORTATION  
RALEIGH

BENT 245 & BENT 246

REVISIONS						SHEET NO.
NO.	BY:	DATE:	NO.	BY:	DATE:	S-292
1			3			TOTAL SHEETS 355
2			4			

DRAWN BY: T. HARTLEY DATE: 2/2019  
CHECKED BY: J. FARNHAM DATE: 4/2019



DOCUMENT NOT CONSIDERED FINAL UNLESS ALL SIGNATURES COMPLETED