

AS-BUILT REPAIR QUANTITY TABLE

BENT 237

CAP REPAIRS			
SHOTCRETE REPAIRS	19.8 SF	9.9 CF	
EPOXY RESIN INJECTION	- LF		
PILE REPAIRS			
PILE CONCRETE RESTORATION	24.8 SF	10.0 CF	
FRP PROTECTIVE SYSTEM AWL	253.0 SF		
FRP PROTECTIVE SYSTEM BWL	99.0 SF		

BENT 238

CAP REPAIRS			
SHOTCRETE REPAIRS	- SF	- CF	
EPOXY RESIN INJECTION	- LF		
PILE REPAIRS			
PILE CONCRETE RESTORATION	6.3 SF	2.7 CF	
FRP PROTECTIVE SYSTEM AWL	159.5 SF		
FRP PROTECTIVE SYSTEM BWL	66.0 SF		

FOR CAP REPAIRS: VALUES IN CHART REPRESENT ESTIMATED REPAIR TOTALS AFTER REMOVAL OF UNSOUND CONCRETE, MIN. OF 1" BEHIND REBAR AND MIN. 2" CL. TO SAWCUT. SEE REPAIR DETAILS.

NOTES:
REPAIR LOCATIONS AND ESTIMATE OF QUANTITIES ARE GIVEN WITH THE BEST INFORMATION AVAILABLE. IF ADDITIONAL REPAIRS NOT SHOWN ON THE DRAWINGS ARE DEEMED NECESSARY BY THE ENGINEER, THE CONTRACTOR SHALL NOTE ON THE DRAWINGS THE APPROXIMATE LOCATION AND DESCRIPTION OF THE REPAIRS AND ADJUST THE ACTUAL QUANTITIES ENTERED INTO THE REPAIR QUANTITY TABLE.

FOR SHOTCRETE REPAIRS, SEE SPECIAL PROVISIONS.
FOR CONCRETE REPAIR DETAILS, SEE "TYPICAL CAP, COLUMN & UNDERDECK REPAIR DETAILS" & "PILE CONCRETE RESTORATION DETAILS" SHEETS.
FOR PILE CONCRETE RESTORATION, SEE SPECIAL PROVISIONS.
FOR FRP PROTECTIVE SYSTEM, SEE SPECIAL PROVISIONS.
FOR FRP PROTECTIVE SYSTEM DETAILS AND UNDERWATER MORTAR REPAIRS, SEE "PILE FRP PROTECTIVE SYSTEM DETAILS" SHEET.

ESTIMATED PILE CRACK QTY. TABLE

		DIRECTION							
		NW	W	SW	S	SE	E	NE	N
BENT 237	PILE 1	3	5	-	-	-	4	-	3
	PILE 2	7	-	-	7	4	3	4	-
	PILE 3	5	7	-	8	7	-	-	-
	PILE 4	-	-	4	4	7	-	-	-
	PILE 6	4	4	-	3	-	-	-	-
BENT 238	PILE 1	2	3	3	-	6	-	6	-
	PILE 2	-	4	-	2	-	-	-	-
	PILE 3	8	4	-	-	4	7	3	8
	PILE 4	-	5	4	-	4	-	-	-

NOTE: FOR INFORMATION ON PILE CONDITION ONLY.

PROJECT NO. HB-0017
DARE COUNTY
 BRIDGE NO. 270009

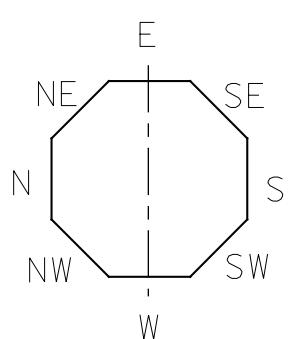

▲ FRP PROTECTIVE SYSTEM BELOW WATERLINE MAY INCLUDE APPROVED UNDERWATER MORTAR REPAIRS

- ERI - EPOXY RESIN INJECTION
- [Hatched Box] - FRP PROTECTIVE SYSTEM
- [Diagonal Lines Box] - PILE CONCRETE RESTORATION
- [Cross-hatched Box] - SHOTCRETE REPAIRS



DocuSigned by:
Eric B. Nelson, Jr. 7/14/2022
 AC8892119214C0...

STATE OF NORTH CAROLINA
 DEPARTMENT OF TRANSPORTATION
 RALEIGH

BENT 237 & BENT 238

REVISIONS						SHEET NO. S-288
NO.	BY:	DATE:	NO.	BY:	DATE:	
1			3			TOTAL SHEETS 355
2			4			

DOCUMENT NOT CONSIDERED FINAL UNLESS ALL SIGNATURES COMPLETED

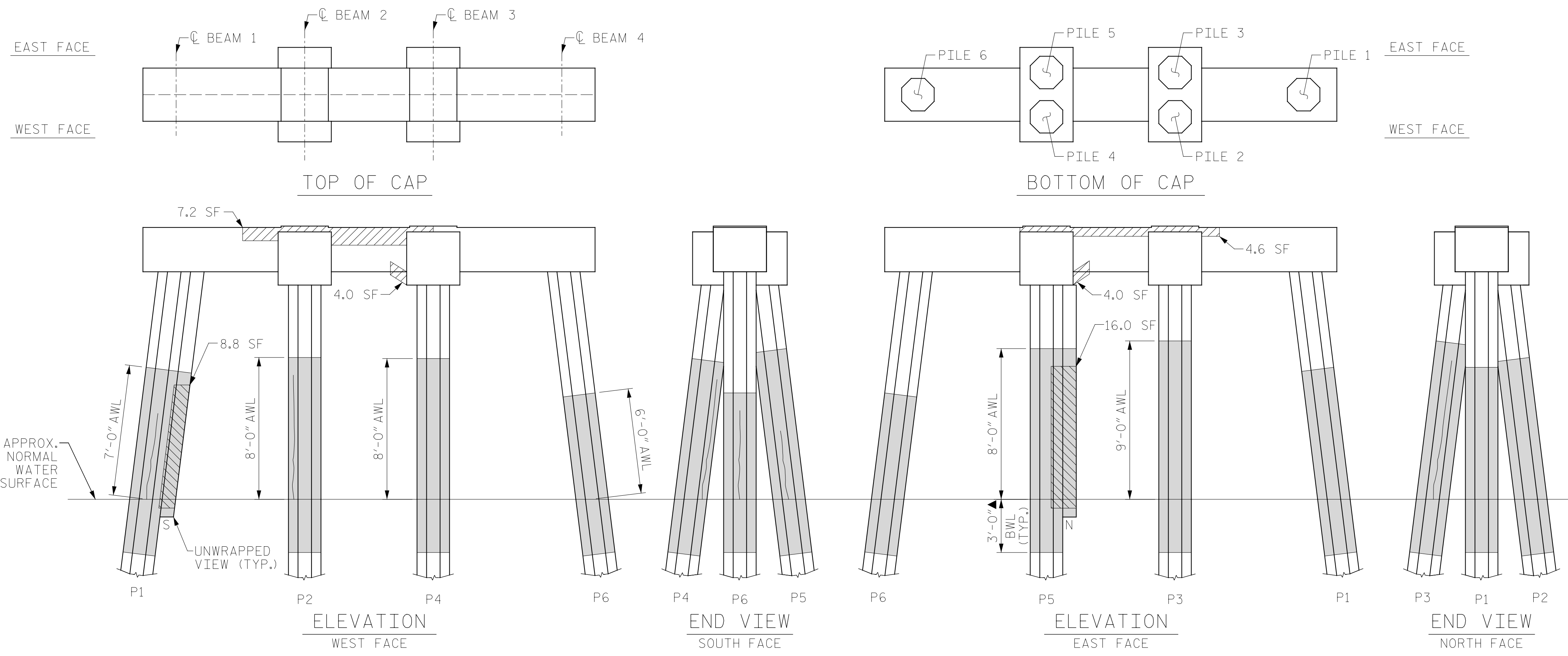

BENT 237

(AWL = ABOVE WATERLINE)
 (BWL = BELOW WATERLINE)
 (**QUANTITY INCLUDES ADJACENT REPAIRS)

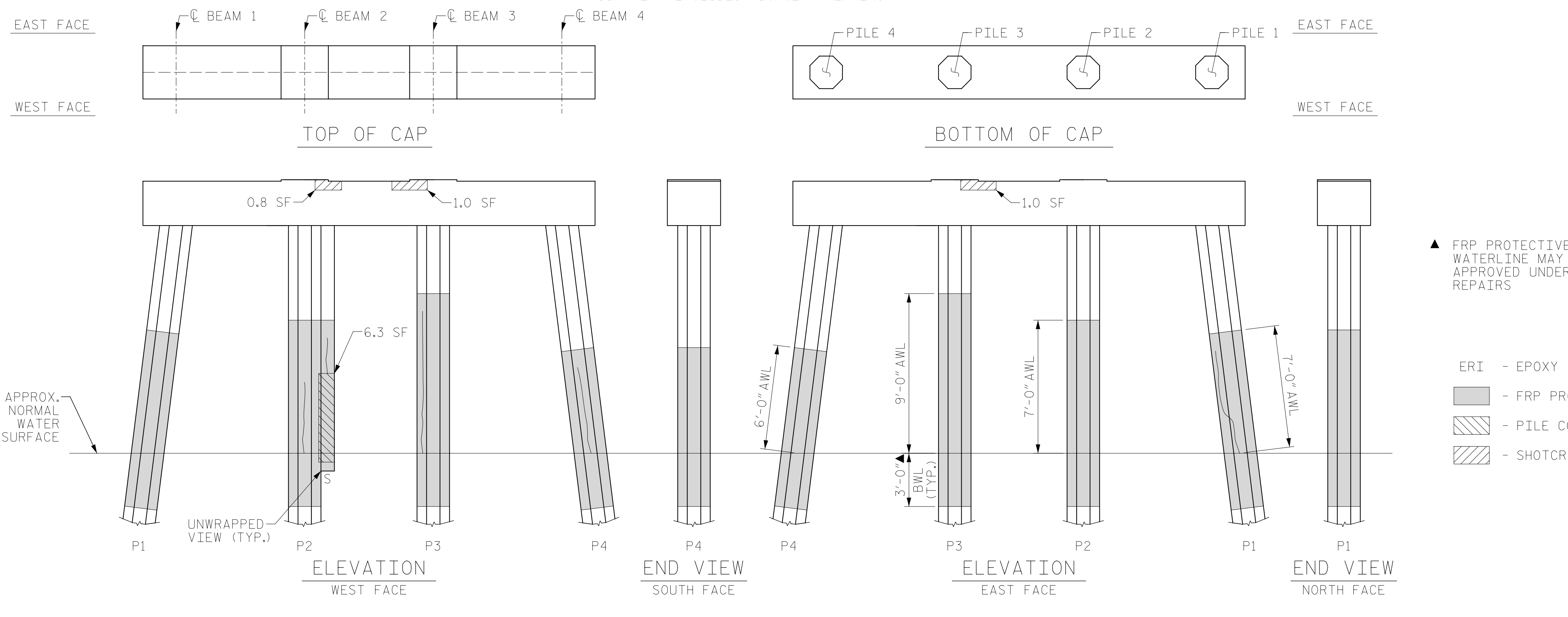

BENT 238

(AWL = ABOVE WATERLINE)
 (BWL = BELOW WATERLINE)
 (**QUANTITY INCLUDES ADJACENT REPAIRS)

DRAWN BY: T. HARTLEY DATE: 2/2019
 CHECKED BY: J. FARNHAM DATE: 4/2019