

AS-BUILT REPAIR QUANTITY TABLE

BENT 235

CAP REPAIRS			
SHOTCRETE REPAIRS	- SF	- CF	SF CF
EPOXY RESIN INJECTION	- LF		LF
PILE REPAIRS			
PILE CONCRETE RESTORATION	23.8 SF	10.1 CF	SF CF
FRP PROTECTIVE SYSTEM AWL	258.5 SF		
FRP PROTECTIVE SYSTEM BWL	99.0 SF		

BENT 236

CAP REPAIRS			
SHOTCRETE REPAIRS	24.1 SF	12.1 CF	SF CF
EPOXY RESIN INJECTION	- LF		LF
PILE REPAIRS			
PILE CONCRETE RESTORATION	49.4 SF	20.4 CF	SF CF
FRP PROTECTIVE SYSTEM AWL	203.5 SF		
FRP PROTECTIVE SYSTEM BWL	66.0 SF		

FOR CAP REPAIRS: VALUES IN CHART REPRESENT ESTIMATED REPAIR TOTALS AFTER REMOVAL OF UNSOUND CONCRETE, MIN. OF 1" BEHIND REBAR AND MIN. 2" CL. TO SAWCUT. SEE REPAIR DETAILS.

NOTES:
REPAIR LOCATIONS AND ESTIMATE OF QUANTITIES ARE GIVEN WITH THE BEST INFORMATION AVAILABLE. IF ADDITIONAL REPAIRS NOT SHOWN ON THE DRAWINGS ARE DEEMED NECESSARY BY THE ENGINEER, THE CONTRACTOR SHALL NOTE ON THE DRAWINGS THE APPROXIMATE LOCATION AND DESCRIPTION OF THE REPAIRS AND ADJUST THE ACTUAL QUANTITIES ENTERED INTO THE REPAIR QUANTITY TABLE.

FOR SHOTCRETE REPAIRS, SEE SPECIAL PROVISIONS.
FOR CONCRETE REPAIR DETAILS, SEE "TYPICAL CAP, COLUMN & UNDERDECK REPAIR DETAILS" & "PILE CONCRETE RESTORATION DETAILS" SHEETS.
FOR PILE CONCRETE RESTORATION, SEE SPECIAL PROVISIONS.
FOR FRP PROTECTIVE SYSTEM, SEE SPECIAL PROVISIONS.
FOR FRP PROTECTIVE SYSTEM DETAILS AND UNDERWATER MORTAR REPAIRS, SEE "PILE FRP PROTECTIVE SYSTEM DETAILS" SHEET.

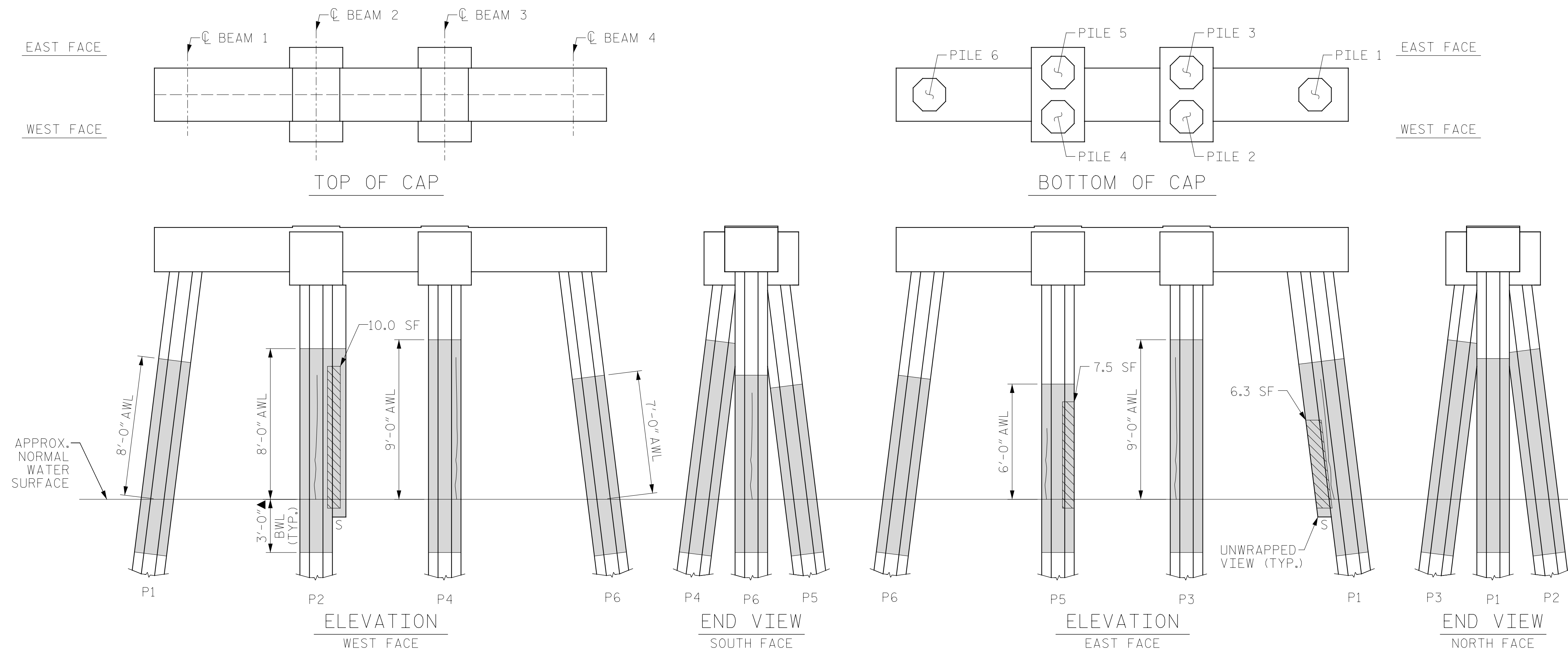

BENT 235

(AWL = ABOVE WATERLINE)
(BWL = BELOW WATERLINE)
(**QUANTITY INCLUDES ADJACENT REPAIRS)

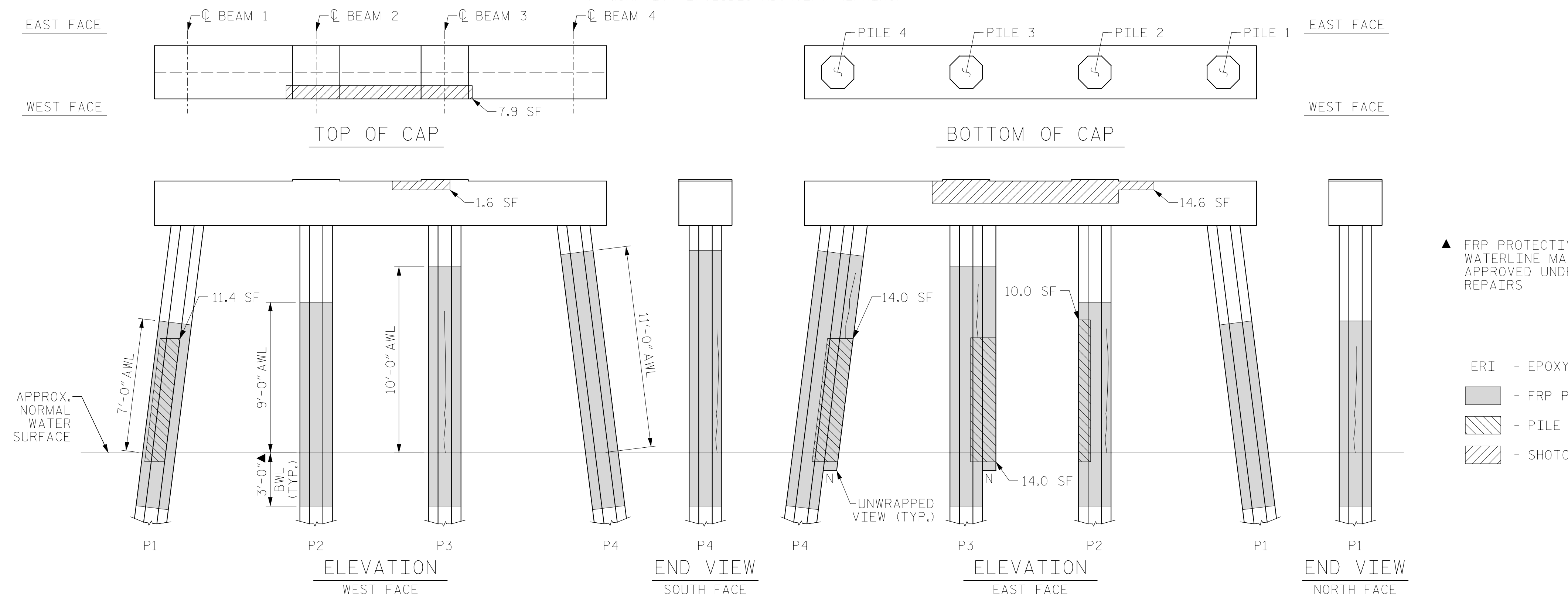

BENT 236

(AWL = ABOVE WATERLINE)
(BWL = BELOW WATERLINE)
(**QUANTITY INCLUDES ADJACENT REPAIRS)

ESTIMATED PILE CRACK QTY. TABLE

		NW	W	SW	S	SE	E	NE	N
BENT 235	PILE 1	-	-	6	-	7	-	4	4
	PILE 2	-	7	-	-	-	-	5	-
	PILE 3	5	7	-	-	8	-	-	-
	PILE 4	-	7	8	-	6	8	-	8
	PILE 5	4	-	4	-	4	-	-	-
	PILE 6	4	-	-	6	-	3	3	6
BENT 236	PILE 1	-	-	-	-	-	-	-	6
	PILE 2	-	-	6	8	-	-	7	-
	PILE 3	-	8	6	3	4	-	3	-
	PILE 4	-	4	4	-	7	-	-	4

NOTE: FOR INFORMATION ON PILE CONDITION ONLY.

PROJECT NO. HB-0017
DARE COUNTY
BRIDGE NO. 270009

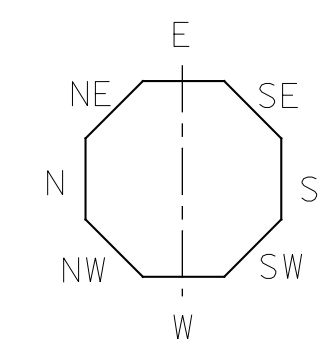

- ▲ FRP PROTECTIVE SYSTEM BELOW WATERLINE MAY INCLUDE APPROVED UNDERWATER MORTAR REPAIRS
- ERI - EPOXY RESIN INJECTION
- [Hatched Box] - FRP PROTECTIVE SYSTEM
- [Diagonal Lines] - PILE CONCRETE RESTORATION
- [Cross-hatched Box] - SHOTCRETE REPAIRS

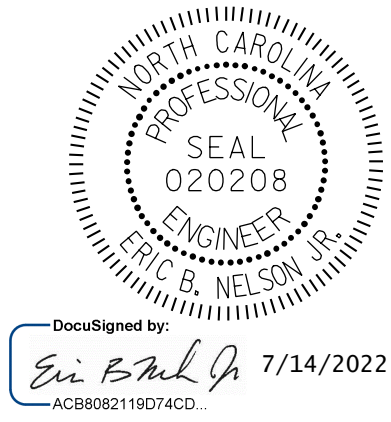

STATE OF NORTH CAROLINA
DEPARTMENT OF TRANSPORTATION
RALEIGH

BENT 235 & BENT 236

DRAWN BY: T. HARTLEY DATE: 2/2019
CHECKED BY: J. FARNHAM DATE: 4/2019



REVISIONS						SHEET NO.
NO.	BY:	DATE:	NO.	BY:	DATE:	S-287
1			3			TOTAL SHEETS
2			4			355

DOCUMENT NOT CONSIDERED FINAL UNLESS ALL SIGNATURES COMPLETED