

AS-BUILT REPAIR QUANTITY TABLE

BENT 217

CAP REPAIRS			
SHOTCRETE REPAIRS	11.3 SF	5.7 CF	SF CF
EPOXY RESIN INJECTION	- LF		LF
PILE REPAIRS			
PILE CONCRETE RESTORATION	30.8 SF	12.7 CF	SF CF
FRP PROTECTIVE SYSTEM AWL	207.4 SF		
FRP PROTECTIVE SYSTEM BWL	73.2 SF		

BENT 218

CAP REPAIRS			
SHOTCRETE REPAIRS	- SF	- CF	SF CF
EPOXY RESIN INJECTION	- LF		LF
PILE REPAIRS			
PILE CONCRETE RESTORATION	30.0 SF	12.0 CF	SF CF
FRP PROTECTIVE SYSTEM AWL	225.7 SF		
FRP PROTECTIVE SYSTEM BWL	73.2 SF		

FOR CAP REPAIRS: VALUES IN CHART REPRESENT ESTIMATED REPAIR TOTALS AFTER REMOVAL OF UNSOUND CONCRETE, MIN. OF 1" BEHIND REBAR AND MIN. 2" CL. TO SAWCUT. SEE REPAIR DETAILS.

NOTES:

REPAIR LOCATIONS AND ESTIMATE OF QUANTITIES ARE GIVEN WITH THE BEST INFORMATION AVAILABLE. IF ADDITIONAL REPAIRS NOT SHOWN ON THE DRAWINGS ARE DEEMED NECESSARY BY THE ENGINEER, THE CONTRACTOR SHALL NOTE ON THE DRAWINGS THE APPROXIMATE LOCATION AND DESCRIPTION OF THE REPAIRS AND ADJUST THE ACTUAL QUANTITIES ENTERED INTO THE REPAIR QUANTITY TABLE.

FOR SHOTCRETE REPAIRS, SEE SPECIAL PROVISIONS.

FOR CONCRETE REPAIR DETAILS, SEE "TYPICAL CAP, COLUMN & UNDERDECK REPAIR DETAILS" & "PILE CONCRETE RESTORATION DETAILS" SHEETS.

FOR PILE CONCRETE RESTORATION, SEE SPECIAL PROVISIONS.

FOR FRP PROTECTIVE SYSTEM, SEE SPECIAL PROVISIONS.

FOR FRP PROTECTIVE SYSTEM DETAILS AND UNDERWATER MORTAR REPAIRS, SEE "PILE FRP PROTECTIVE SYSTEM DETAILS" SHEET.

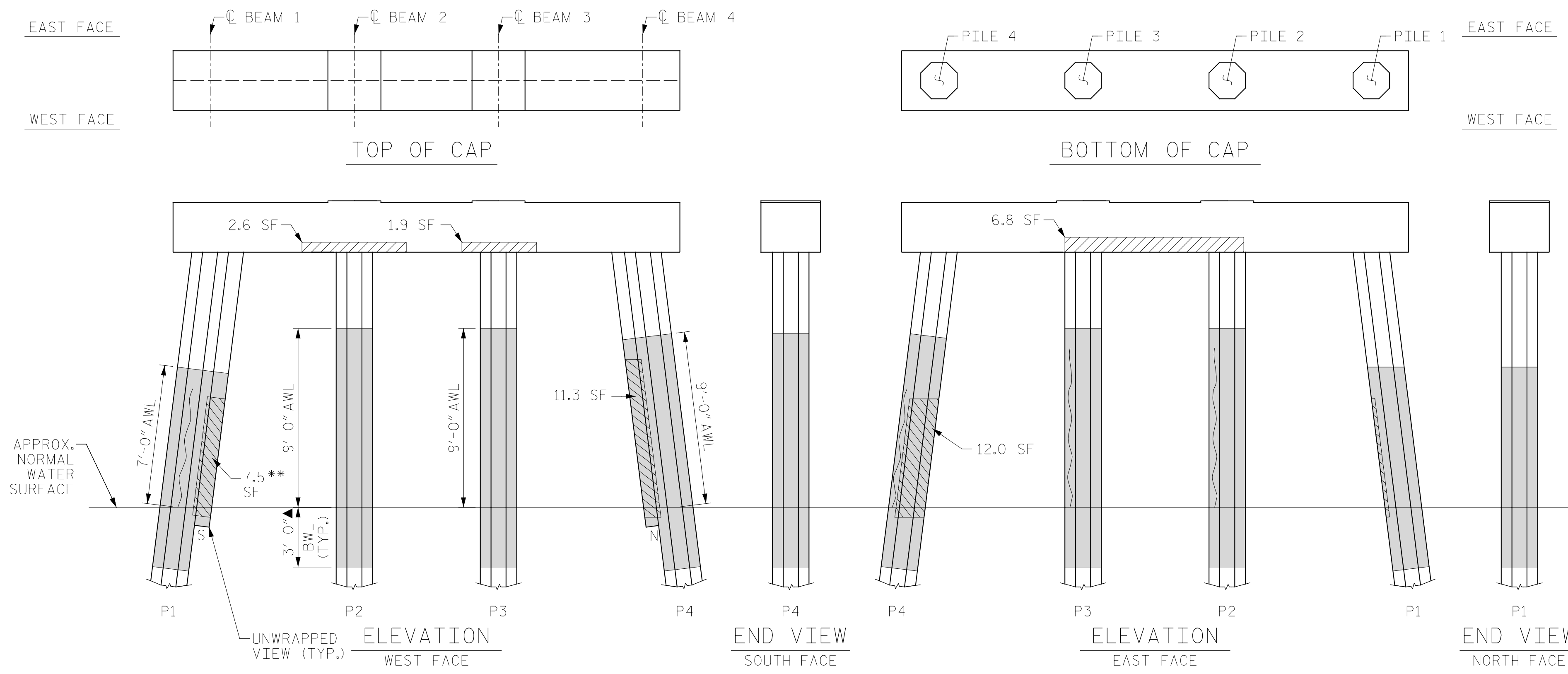

BENT 217

(AWL = ABOVE WATERLINE)
(BWL = BELOW WATERLINE)
(**QUANTITY INCLUDES ADJACENT REPAIRS)

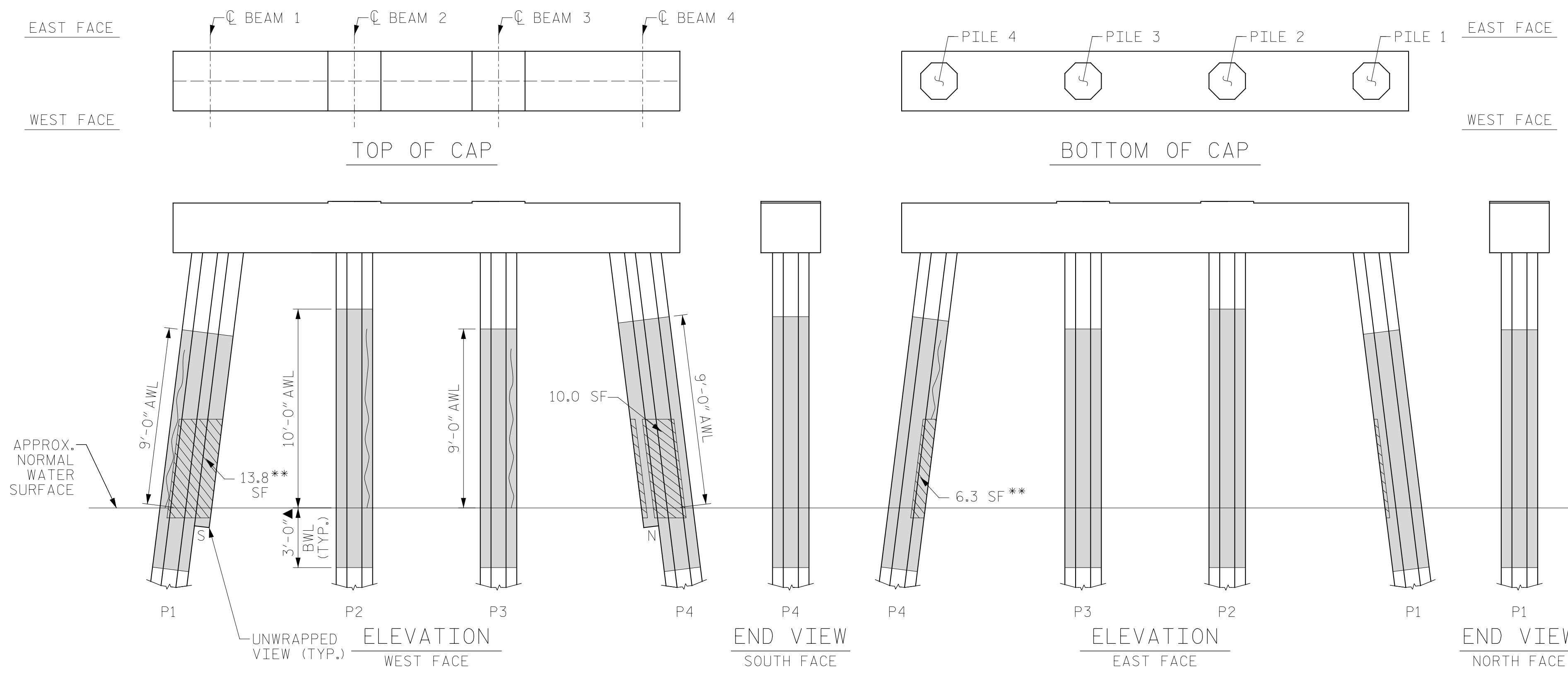

BENT 218

(AWL = ABOVE WATERLINE)
(BWL = BELOW WATERLINE)
(**QUANTITY INCLUDES ADJACENT REPAIRS)

ESTIMATED PILE CRACK QTY. TABLE

	NW	W	SW	S	SE	E	NE	N
BENT 217	PILE 1	3	6	6	-	-	6	3
	PILE 2	-	4	-	2	8	-	5
	PILE 3	-	3	-	8	8	-	7
	PILE 4	3	-	3	5	6	-	-
BENT 218	PILE 1	8	-	-	-	6	5	-
	PILE 2	-	-	9	-	8	8	9
	PILE 3	-	-	8	-	7	6	8
	PILE 4	4	4	-	6	-	6	4

NOTE: FOR INFORMATION ON PILE CONDITION ONLY.

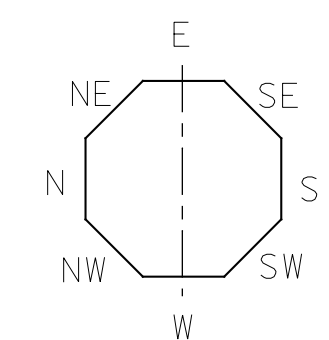

▲ FRP PROTECTIVE SYSTEM BELOW WATERLINE MAY INCLUDE APPROVED UNDERWATER MORTAR REPAIRS

- ERI - EPOXY RESIN INJECTION
- [Hatched Box] - FRP PROTECTIVE SYSTEM
- [Diagonal Lines Box] - PILE CONCRETE RESTORATION
- [Cross-hatched Box] - SHOTCRETE REPAIRS

PROJECT NO. HB-0017
DARE COUNTY
BRIDGE NO. 270009

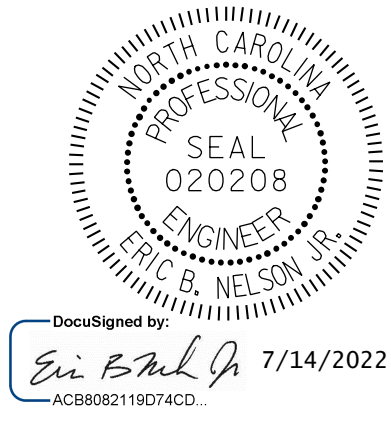

STATE OF NORTH CAROLINA
DEPARTMENT OF TRANSPORTATION
RALEIGH
BENT 217 & BENT 218

DRAWN BY: T. HARTLEY DATE: 2/2019
CHECKED BY: J. FARNHAM DATE: 4/2019



DOCUMENT NOT CONSIDERED FINAL UNLESS ALL SIGNATURES COMPLETED

REVISIONS						SHEET NO.
NO.	BY:	DATE:	NO.	BY:	DATE:	TOTAL SHEETS
1			3			355
2			4			