

AS-BUILT REPAIR QUANTITY TABLE

BENT 183

CAP REPAIRS			
SHOTCRETE REPAIRS	9.8 SF	4.9 CF	SF CF
EPOXY RESIN INJECTION	- LF		LF
PILE REPAIRS			
PILE CONCRETE RESTORATION	29.2 SF	12.0 CF	SF CF
FRP PROTECTIVE SYSTEM AWL	103.7 SF		
FRP PROTECTIVE SYSTEM BWL	36.6 SF		

BENT 184

CAP REPAIRS			
SHOTCRETE REPAIRS	13.4 SF	6.7 CF	SF CF
EPOXY RESIN INJECTION	- LF		LF
PILE REPAIRS			
PILE CONCRETE RESTORATION	41.1 SF	17.5 CF	SF CF
FRP PROTECTIVE SYSTEM AWL	189.1 SF		
FRP PROTECTIVE SYSTEM BWL	73.2 SF		

FOR CAP REPAIRS: VALUES IN CHART REPRESENT ESTIMATED REPAIR TOTALS AFTER REMOVAL OF UNSOUND CONCRETE, MIN. OF 1" BEHIND REBAR AND MIN. 2" CL. TO SAWCUT. SEE REPAIR DETAILS.

NOTES:
REPAIR LOCATIONS AND ESTIMATE OF QUANTITIES ARE GIVEN WITH THE BEST INFORMATION AVAILABLE. IF ADDITIONAL REPAIRS NOT SHOWN ON THE DRAWINGS ARE DEEMED NECESSARY BY THE ENGINEER, THE CONTRACTOR SHALL NOTE ON THE DRAWINGS THE APPROXIMATE LOCATION AND DESCRIPTION OF THE REPAIRS AND ADJUST THE ACTUAL QUANTITIES ENTERED INTO THE REPAIR QUANTITY TABLE.

FOR SHOTCRETE REPAIRS, SEE SPECIAL PROVISIONS.
FOR CONCRETE REPAIR DETAILS, SEE "TYPICAL CAP, COLUMN & UNDERDECK REPAIR DETAILS" & "PILE CONCRETE RESTORATION DETAILS" SHEETS.
FOR PILE CONCRETE RESTORATION, SEE SPECIAL PROVISIONS.
FOR FRP PROTECTIVE SYSTEM, SEE SPECIAL PROVISIONS.
FOR FRP PROTECTIVE SYSTEM DETAILS AND UNDERWATER MORTAR REPAIRS, SEE "PILE FRP PROTECTIVE SYSTEM DETAILS" SHEET.

ESTIMATED PILE CRACK QTY. TABLE

		NW	W	SW	S	SE	E	NE	N
BENT 183	PILE 1	6	3	-	3	-	-	1	1
	PILE 2	-	-	-	-	-	-	-	-
	PILE 3	-	-	-	-	-	-	-	-
	PILE 4	-	-	-	-	-	-	-	-
	PILE 5	-	-	-	-	-	-	-	-
	PILE 6	5	3	-	5	2	-	-	4
BENT 184	PILE 1	6	-	-	-	-	-	6	-
	PILE 2	-	-	-	8	-	6	-	-
	PILE 3	-	-	4	-	5	-	-	-
	PILE 4	-	6	5	-	-	7	-	8

NOTE: FOR INFORMATION ON PILE CONDITION ONLY.

PROJECT NO. HB-0017
DARE COUNTY
 BRIDGE NO. 270009



STATE OF NORTH CAROLINA
 DEPARTMENT OF TRANSPORTATION
 RALEIGH

BENT 183 & BENT 184

REVISIONS						SHEET NO.
NO.	BY:	DATE:	NO.	BY:	DATE:	S-261
1			3			TOTAL SHEETS
2			4			355

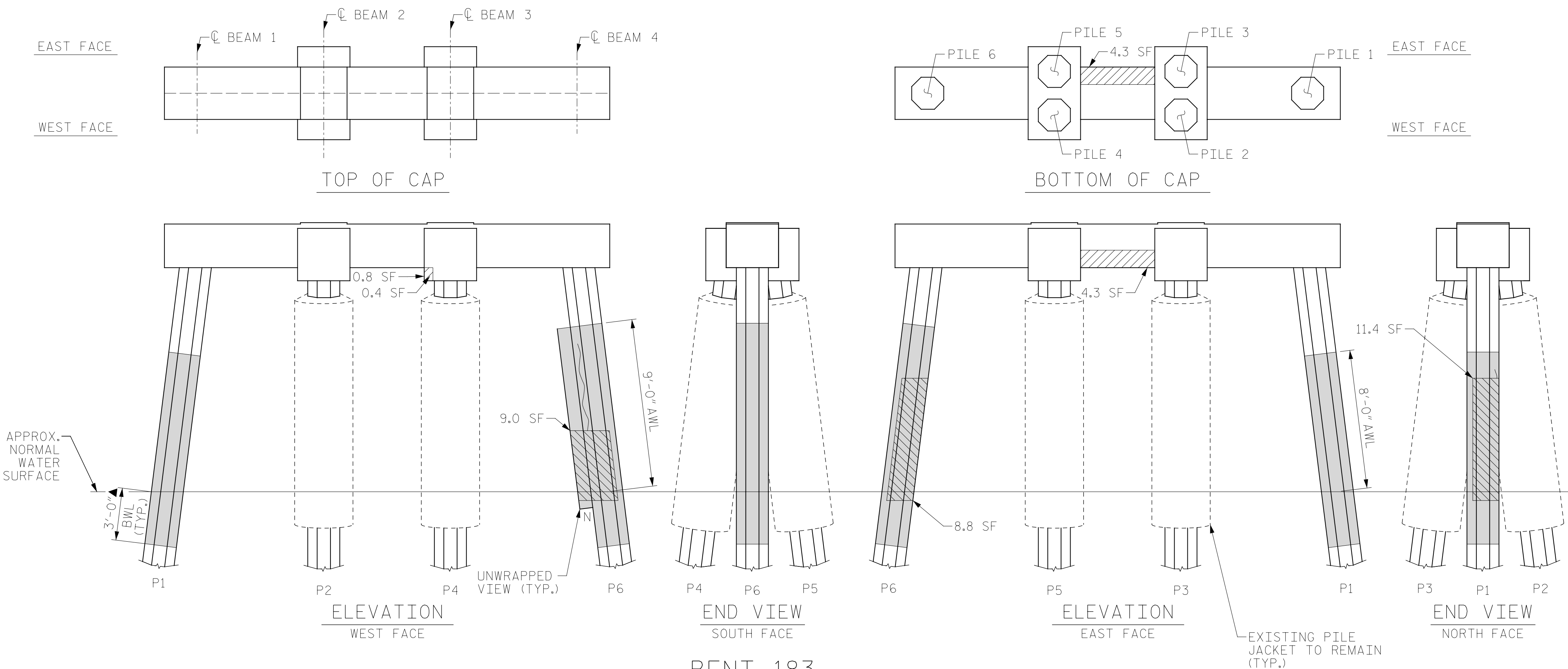

BENT 183

(AWL = ABOVE WATERLINE)
 (BWL = BELOW WATERLINE)
 (**QUANTITY INCLUDES ADJACENT REPAIRS)

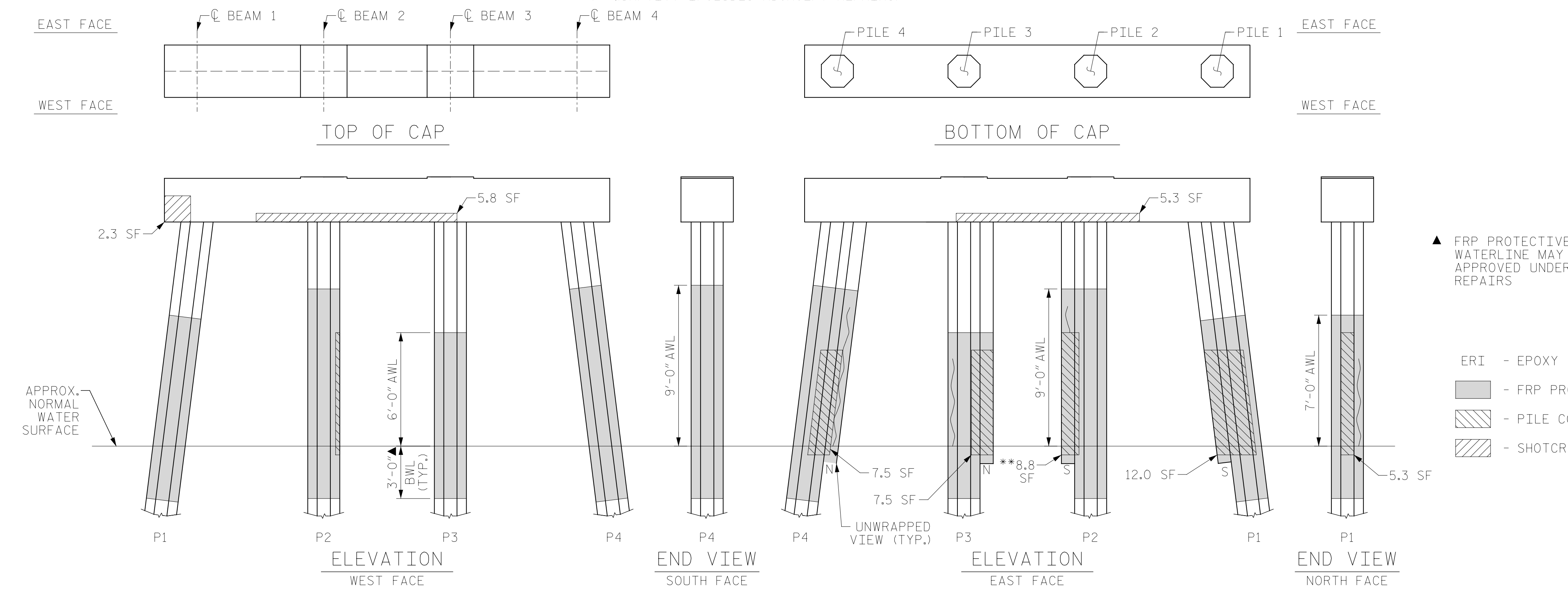

BENT 184

(AWL = ABOVE WATERLINE)
 (BWL = BELOW WATERLINE)
 (**QUANTITY INCLUDES ADJACENT REPAIRS)

- ▲ FRP PROTECTIVE SYSTEM BELOW WATERLINE MAY INCLUDE APPROVED UNDERWATER MORTAR REPAIRS
- ERI - EPOXY RESIN INJECTION
- [Hatched Box] - FRP PROTECTIVE SYSTEM
- [Diagonal Lines] - PILE CONCRETE RESTORATION
- [Cross-hatched Box] - SHOTCRETE REPAIRS

DRAWN BY: T. HARTLEY DATE: 2/2019
 CHECKED BY: J. FARNHAM DATE: 4/2019



DOCUMENT NOT CONSIDERED FINAL UNLESS ALL SIGNATURES COMPLETED