

AS-BUILT REPAIR QUANTITY TABLE

BENT 129

CAP REPAIRS		ESTIMATE		ACTUAL	
SHOTCRETE REPAIRS	7.1 SF	3.6 CF	SF	CF	
EPOXY RESIN INJECTION	- LF				LF
COLUMN REPAIRS		ESTIMATE		ACTUAL	
SHOTCRETE REPAIRS	50.5 SF	25.3 CF	SF	CF	
EPOXY RESIN INJECTION	4.3 LF				LF
PILE REPAIRS		ESTIMATE		ACTUAL	
FRP PROTECTIVE SYSTEM AWL	- SF				SF
FRP PROTECTIVE SYSTEM BWL	363.0 SF				SF

FOR CAP REPAIRS; VALUES IN CHART REPRESENT ESTIMATED REPAIR TOTALS AFTER REMOVAL OF UNSOUND CONCRETE, MIN. OF 1" BEHIND REBAR AND MIN. 2" CL TO SAWCUT. SEE REPAIR DETAILS.

NOTES:
 REPAIR LOCATIONS AND ESTIMATE OF QUANTITIES ARE GIVEN WITH THE BEST INFORMATION AVAILABLE. IF ADDITIONAL REPAIRS NOT SHOWN ON THE DRAWINGS ARE DEEMED NECESSARY BY THE ENGINEER THE CONTRACTOR SHALL NOTE ON THE DRAWINGS THE APPROXIMATE LOCATION AND DESCRIPTION OF THE REPAIRS AND ADJUST THE ACTUAL QUANTITIES ENTERED INTO THE REPAIR QUANTITY TABLE.
 FOR SHOTCRETE REPAIRS, SEE SPECIAL PROVISIONS.
 FOR CONCRETE REPAIR DETAILS, SEE "TYPICAL CAP, COLUMN & UNDERDECK REPAIR DETAILS" & "PILE CONCRETE RESTORATION DETAILS" SHEETS.
 FOR FOOTING, COLUMN, AND STRUT REPAIR DETAILS, SEE "PILE FOOTING RESTORATION" SHEET.
 FOR PILE CONCRETE RESTORATION, SEE SPECIAL PROVISIONS.
 FOR FRP PROTECTIVE SYSTEM, SEE SPECIAL PROVISIONS.
 FOR FRP PROTECTIVE SYSTEM DETAILS AND UNDERWATER MORTAR REPAIRS, SEE "PILE FRP PROTECTIVE SYSTEM DETAILS" SHEET.

- ERI - EPOXY RESIN INJECTION
- FRP PROTECTIVE SYSTEM
- SHOTCRETE REPAIRS
- PILE FOOTING RESTORATION

▲ FRP PROTECTIVE SYSTEM BELOW WATERLINE MAY INCLUDE APPROVED UNDERWATER MORTAR REPAIRS

PROJECT NO. HB-0017
DARE COUNTY
 BRIDGE NO. 270009

STATE OF NORTH CAROLINA
DEPARTMENT OF TRANSPORTATION
RALEIGH

BENT 129
WEST FACE

REVISIONS						SHEET NO.
NO.	BY:	DATE:	NO.	BY:	DATE:	TOTAL SHEETS
1			3			355
2			4			



DOCUMENT NOT CONSIDERED FINAL UNLESS ALL SIGNATURES COMPLETED

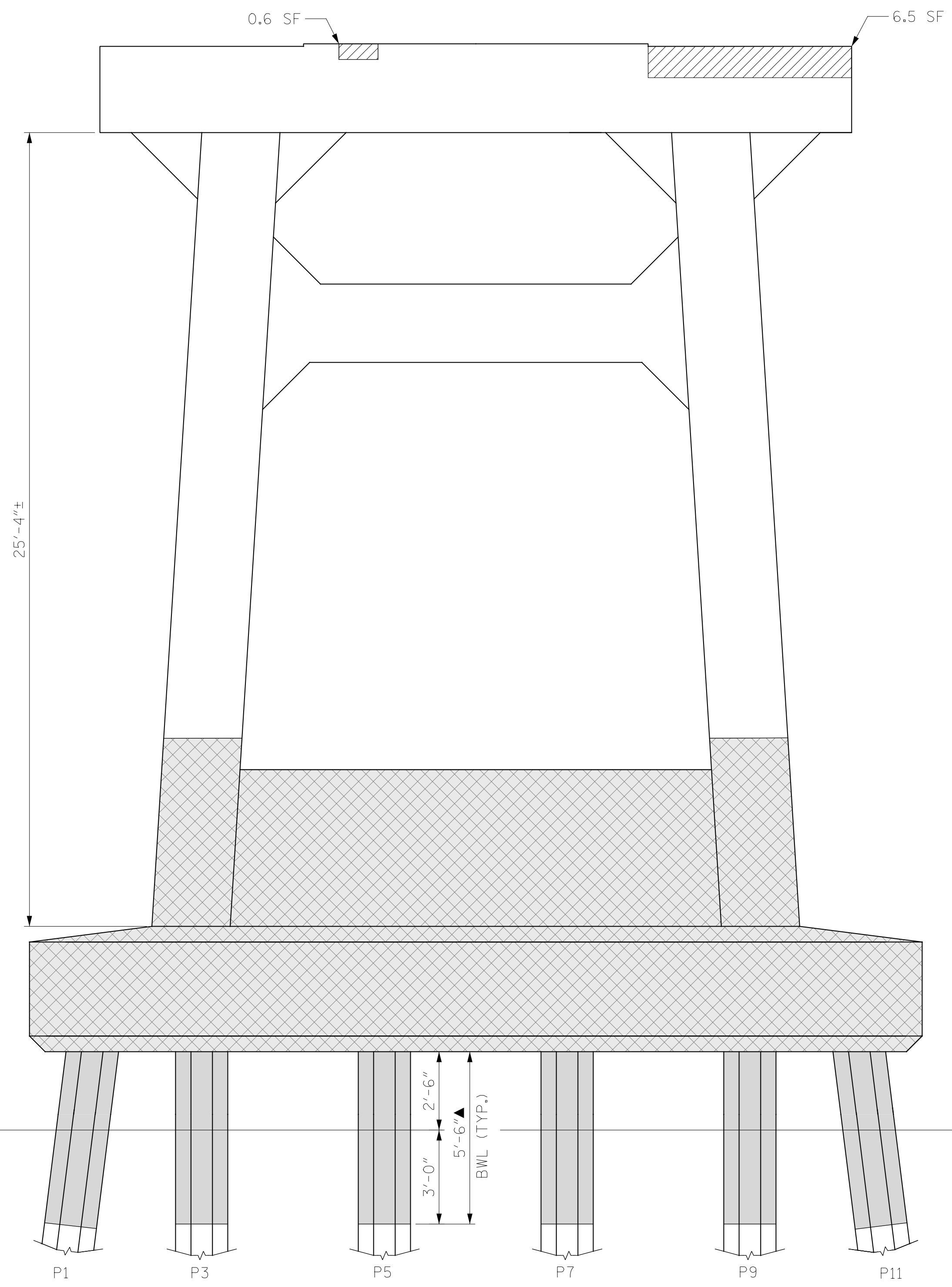
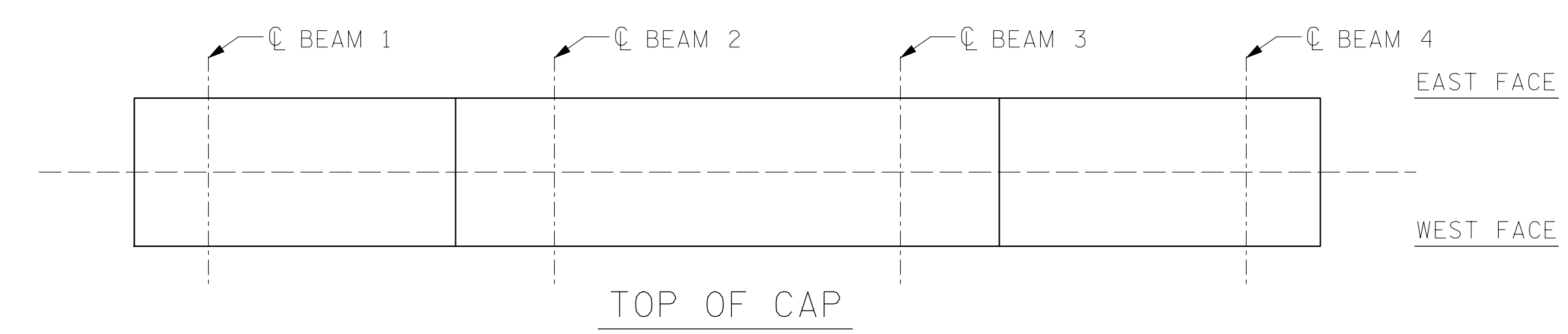

ELEVATION
WEST FACE

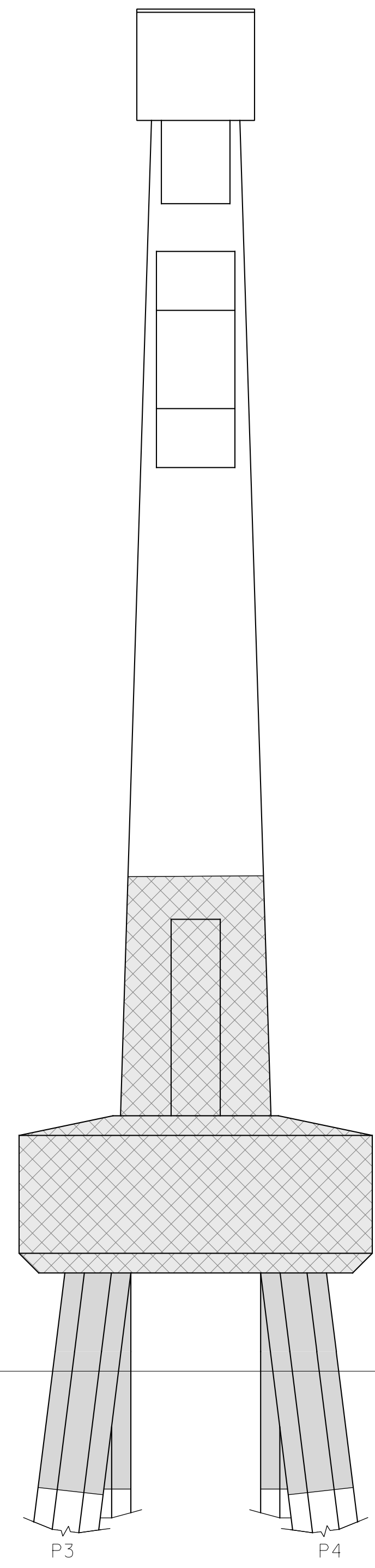

INTERIOR VIEW
SOUTH FACE COL.1

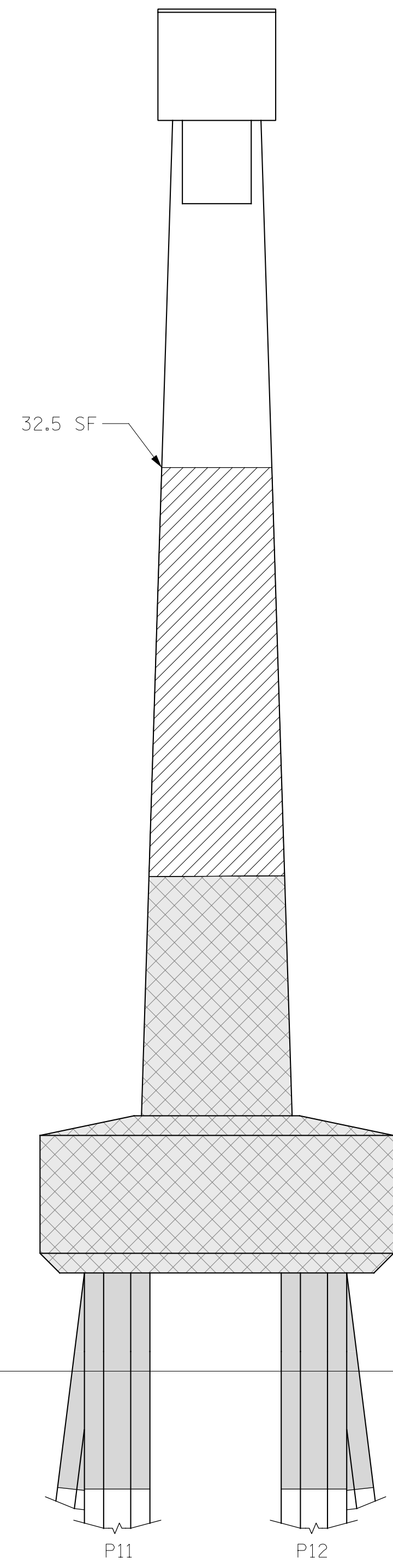

END VIEW
SOUTH FACE COL.2

BENT 129
 (AWL = ABOVE WATERLINE)
 (BWL = BELOW WATERLINE)

DRAWN BY: T. HARTLEY DATE: 2/2019
 CHECKED BY: J. FARNHAM DATE: 5/2019