

AS-BUILT REPAIR QUANTITY TABLE

BENT 105

CAP REPAIRS				
SHOTCRETE REPAIRS	- SF	- CF	SF	CF
EPOXY RESIN INJECTION	- LF			LF
PILE REPAIRS				
PILE CONCRETE RESTORATION	52.5 SF	21.8 CF	SF	CF
FRP PROTECTIVE SYSTEM AWL	187.0 SF			
FRP PROTECTIVE SYSTEM BWL	66.0 SF			

BENT 106

CAP REPAIRS				
SHOTCRETE REPAIRS	1.4 SF	0.7 CF	SF	CF
EPOXY RESIN INJECTION	- LF			LF
PILE REPAIRS				
PILE CONCRETE RESTORATION	49.1 SF	19.8 CF	SF	CF
FRP PROTECTIVE SYSTEM AWL	165.0 SF			
FRP PROTECTIVE SYSTEM BWL	66.0 SF			

FOR CAP REPAIRS: VALUES IN CHART REPRESENT ESTIMATED REPAIR TOTALS AFTER REMOVAL OF UNSOUND CONCRETE, MIN. OF 1" BEHIND REBAR AND MIN. 2" CL. TO SAWCUT. SEE REPAIR DETAILS.

NOTES:

REPAIR LOCATIONS AND ESTIMATE OF QUANTITIES ARE GIVEN WITH THE BEST INFORMATION AVAILABLE. IF ADDITIONAL REPAIRS NOT SHOWN ON THE DRAWINGS ARE DEEMED NECESSARY BY THE ENGINEER, THE CONTRACTOR SHALL NOTE ON THE DRAWINGS THE APPROXIMATE LOCATION AND DESCRIPTION OF THE REPAIRS AND ADJUST THE ACTUAL QUANTITIES ENTERED INTO THE REPAIR QUANTITY TABLE.

FOR SHOTCRETE REPAIRS, SEE SPECIAL PROVISIONS.

FOR CONCRETE REPAIR DETAILS, SEE "TYPICAL CAP, COLUMN & UNDERDECK REPAIR DETAILS" & "PILE CONCRETE RESTORATION DETAILS" SHEETS.

FOR PILE CONCRETE RESTORATION, SEE SPECIAL PROVISIONS.

FOR FRP PROTECTIVE SYSTEM, SEE SPECIAL PROVISIONS.

FOR FRP PROTECTIVE SYSTEM DETAILS AND UNDERWATER MORTAR REPAIRS, SEE "PILE FRP PROTECTIVE SYSTEM DETAILS" SHEET.

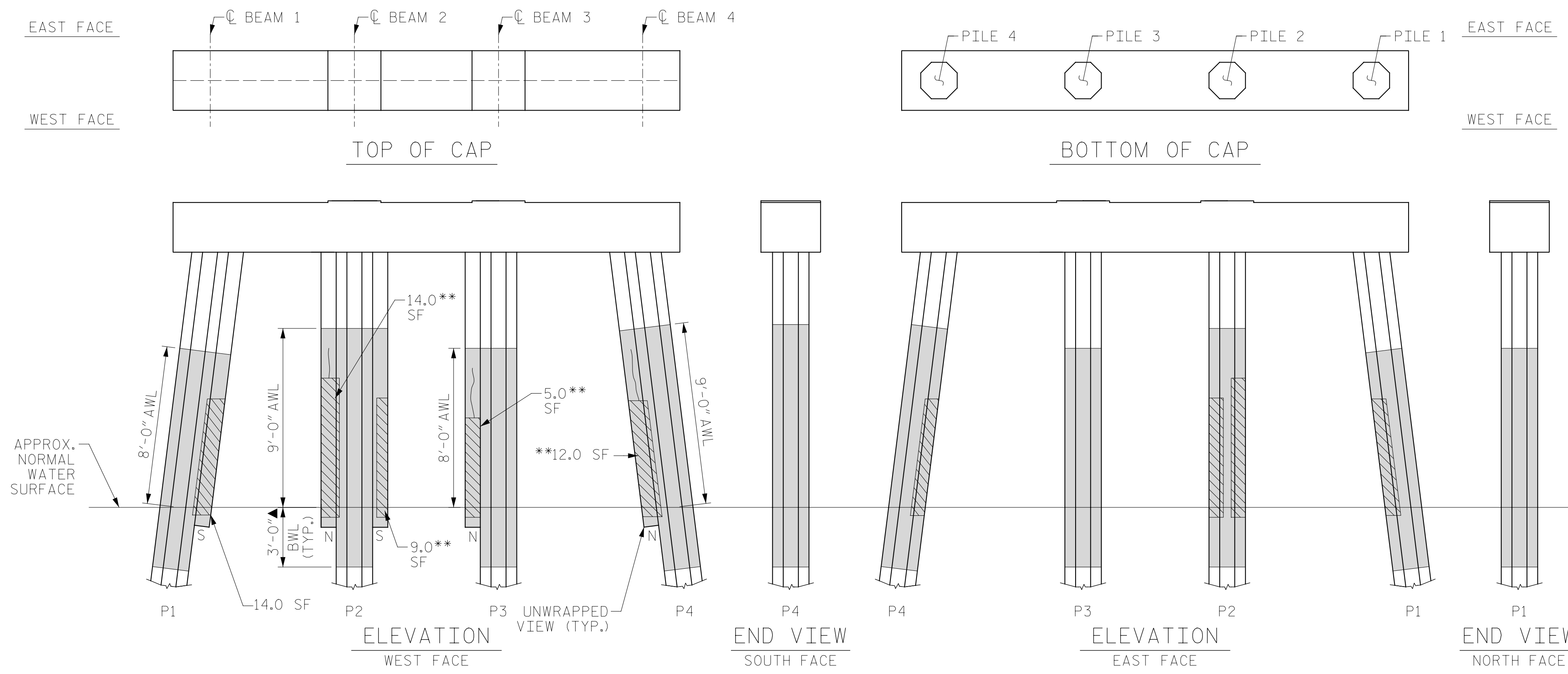

BENT 105

(AWL = ABOVE WATERLINE)
(BWL = BELOW WATERLINE)
(*QUANTITY INCLUDES ADJACENT REPAIRS)

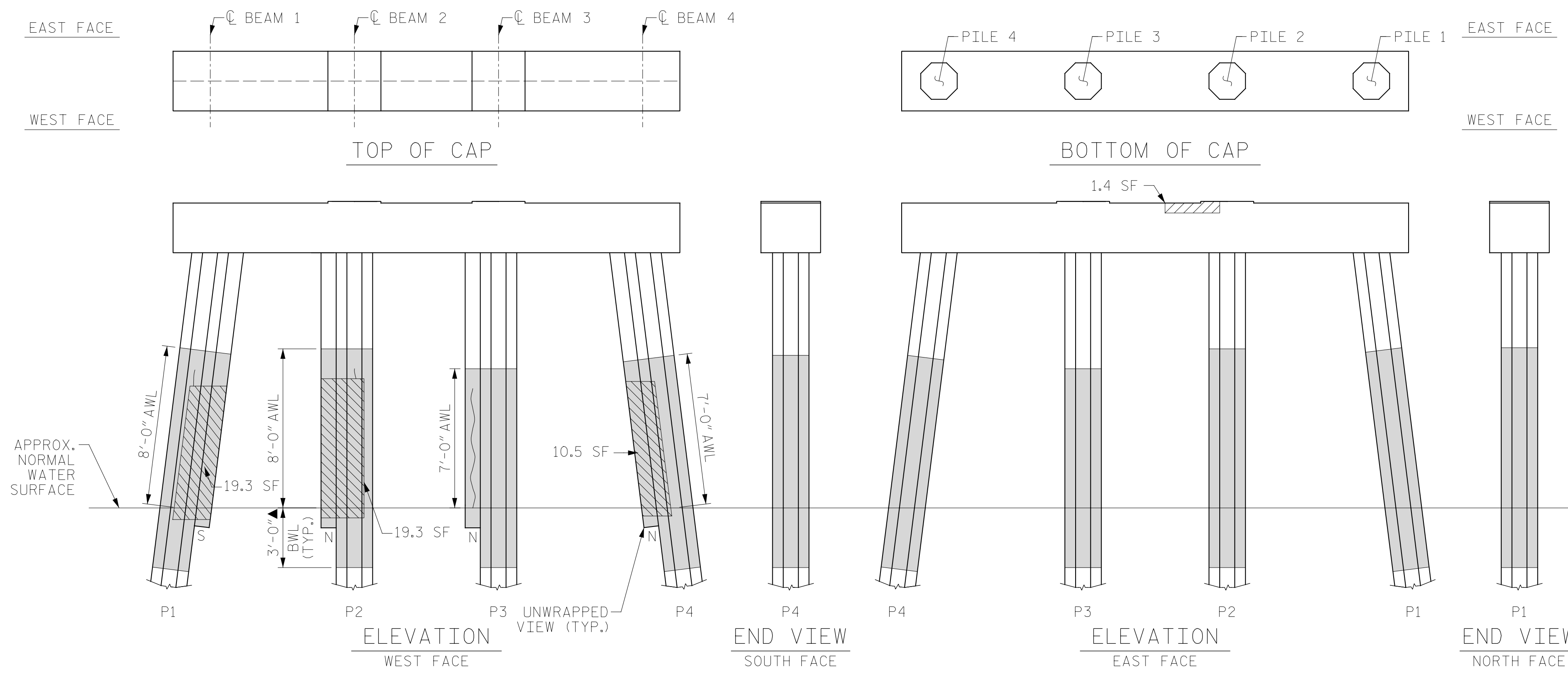

BENT 106

(AWL = ABOVE WATERLINE)
(BWL = BELOW WATERLINE)
(*QUANTITY INCLUDES ADJACENT REPAIRS)

ESTIMATED PILE CRACK QTY. TABLE

BENT	PILE	DIRECTION							
		NW	W	SW	S	SE	E	NE	N
105	PILE 1	-	-	4	1	-	-	4	-
	PILE 2	-	2	-	-	-	-	2	2
	PILE 3	-	-	4	-	6	2	7	3
	PILE 4	4	-	3	3	5	4	-	3
106	PILE 1	-	-	1	-	-	6	5	3
	PILE 2	-	1	4	11	4	-	-	-
	PILE 3	3	4	4	3	4	3	6	6
	PILE 4	-	6	5	4	-	-	6	-

NOTE: FOR INFORMATION ON PILE CONDITION ONLY.

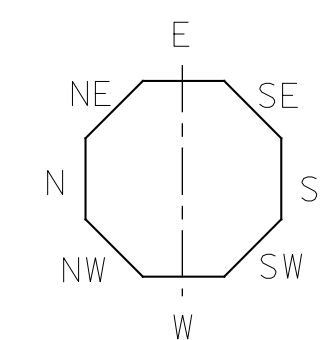

▲ FRP PROTECTIVE SYSTEM BELOW WATERLINE MAY INCLUDE APPROVED UNDERWATER MORTAR REPAIRS

- ERI - EPOXY RESIN INJECTION
- [Hatched Box] - FRP PROTECTIVE SYSTEM
- [Diagonal Lines Box] - PILE CONCRETE RESTORATION
- [Cross-hatched Box] - SHOTCRETE REPAIRS

PROJECT NO. HB-0017
DARE COUNTY
 BRIDGE NO. 270009

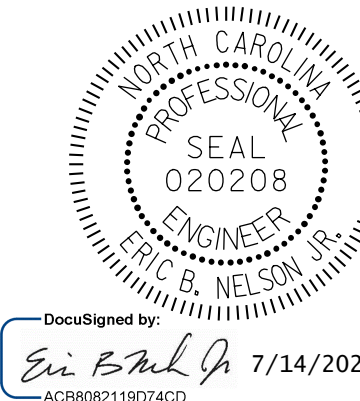

STATE OF NORTH CAROLINA
 DEPARTMENT OF TRANSPORTATION
 RALEIGH

BENT 105 & BENT 106

DRAWN BY: T. HARTLEY DATE: 2/2019
 CHECKED BY: R. FISHER DATE: 3/2019



DOCUMENT NOT CONSIDERED FINAL UNLESS ALL SIGNATURES COMPLETED

REVISIONS						SHEET NO.
NO.	BY:	DATE:	NO.	BY:	DATE:	S-168
1			3			TOTAL SHEETS
2			4			355