

AS-BUILT REPAIR QUANTITY TABLE

BENT 101

CAP REPAIRS			
SHOTCRETE REPAIRS	1.0 SF	0.5 CF	
EPOXY RESIN INJECTION	- LF		
PILE REPAIRS			
PILE CONCRETE RESTORATION	67.8 SF	27.2 CF	
FRP PROTECTIVE SYSTEM AWL	269.5 SF		
FRP PROTECTIVE SYSTEM BWL	99.0 SF		

BENT 102

CAP REPAIRS			
SHOTCRETE REPAIRS	- SF	- CF	
EPOXY RESIN INJECTION	- LF		
PILE REPAIRS			
PILE CONCRETE RESTORATION	59.1 SF	23.0 CF	
FRP PROTECTIVE SYSTEM AWL	165.0 SF		
FRP PROTECTIVE SYSTEM BWL	66.0 SF		

FOR CAP REPAIRS: VALUES IN CHART REPRESENT ESTIMATED REPAIR TOTALS AFTER REMOVAL OF UNSOUND CONCRETE, MIN. OF 1" BEHIND REBAR AND MIN. 2" CL. TO SAWCUT. SEE REPAIR DETAILS.

NOTES:
REPAIR LOCATIONS AND ESTIMATE OF QUANTITIES ARE GIVEN WITH THE BEST INFORMATION AVAILABLE. IF ADDITIONAL REPAIRS NOT SHOWN ON THE DRAWINGS ARE DEEMED NECESSARY BY THE ENGINEER, THE CONTRACTOR SHALL NOTE ON THE DRAWINGS THE APPROXIMATE LOCATION AND DESCRIPTION OF THE REPAIRS AND ADJUST THE ACTUAL QUANTITIES ENTERED INTO THE REPAIR QUANTITY TABLE.

FOR SHOTCRETE REPAIRS, SEE SPECIAL PROVISIONS.
FOR CONCRETE REPAIR DETAILS, SEE "TYPICAL CAP, COLUMN & UNDERDECK REPAIR DETAILS" & "PILE CONCRETE RESTORATION DETAILS" SHEETS.
FOR PILE CONCRETE RESTORATION, SEE SPECIAL PROVISIONS.
FOR FRP PROTECTIVE SYSTEM, SEE SPECIAL PROVISIONS.
FOR FRP PROTECTIVE SYSTEM DETAILS AND UNDERWATER MORTAR REPAIRS, SEE "PILE FRP PROTECTIVE SYSTEM DETAILS" SHEET.

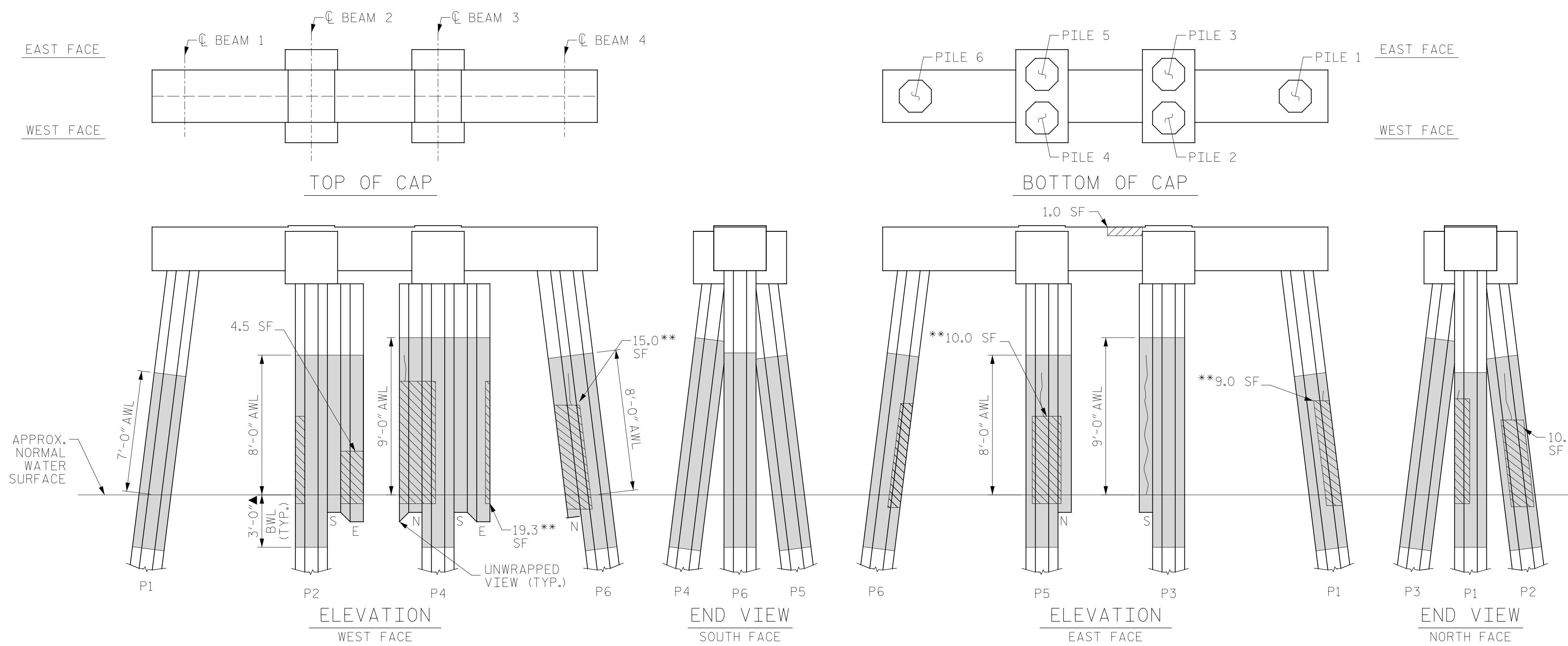

BENT 101

(AWL = ABOVE WATERLINE)
(BWL = BELOW WATERLINE)
(**QUANTITY INCLUDES ADJACENT REPAIRS)

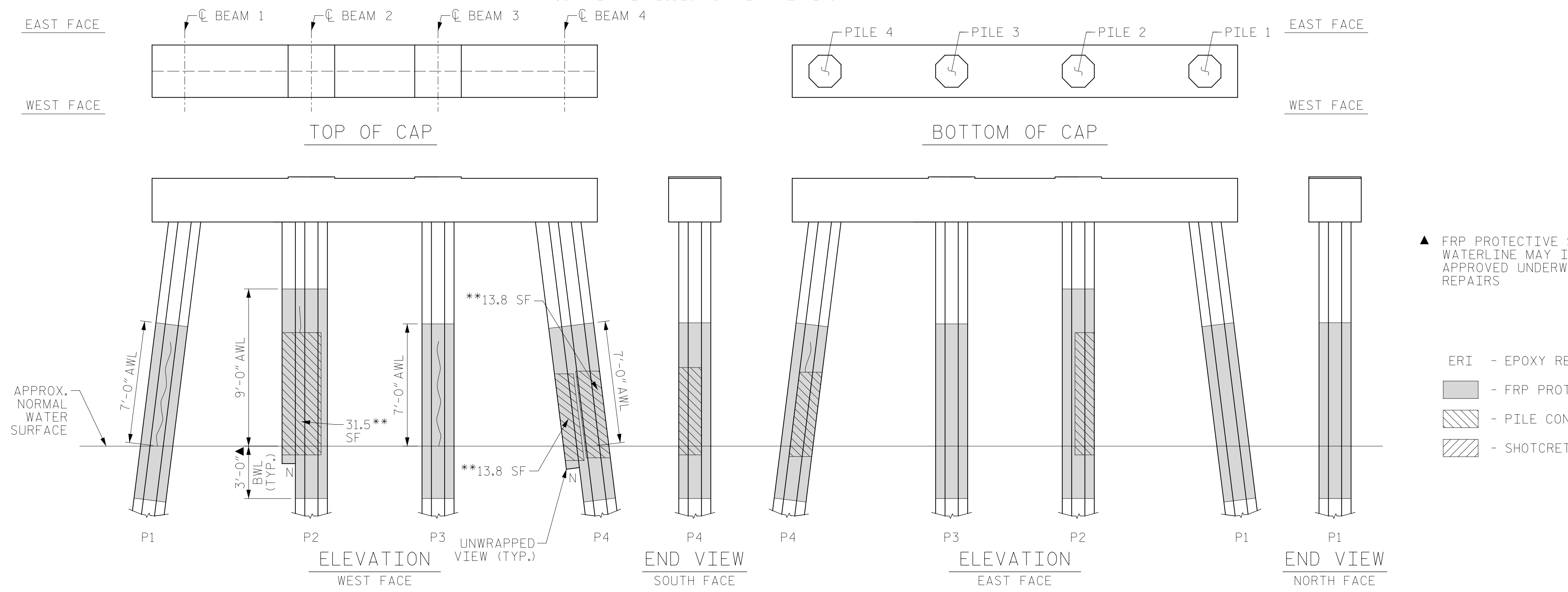

BENT 102

(AWL = ABOVE WATERLINE)
(BWL = BELOW WATERLINE)
(**QUANTITY INCLUDES ADJACENT REPAIRS)

BENT	PILE	DIRECTION							
		NW	W	SW	S	SE	E	NE	N
BENT 101	PILE 1	5	3	2	4	4	1	1	-
	PILE 2	2	-	2	4	-	-	7	3
	PILE 3	6	6	5	8	-	-	4	5
	PILE 4	-	-	3	6	7	-	2	1
	PILE 5	-	-	2	-	-	3	-	4
	PILE 6	2	6	4	-	-	-	2	-
BENT 102	PILE 1	6	6	5	6	3	3	3	4
	PILE 2	2	-	-	-	3	-	-	-
	PILE 3	-	6	-	6	5	3	-	-
	PILE 4	2	-	-	-	-	2	-	-

NOTE: FOR INFORMATION ON PILE CONDITION ONLY.
PROJECT NO. HB-0017
DARE COUNTY
BRIDGE NO. 270009

- ▲ FRP PROTECTIVE SYSTEM BELOW WATERLINE MAY INCLUDE APPROVED UNDERWATER MORTAR REPAIRS
- ERI - EPOXY RESIN INJECTION
- FRP PROTECTIVE SYSTEM
- PILE CONCRETE RESTORATION
- SHOTCRETE REPAIRS

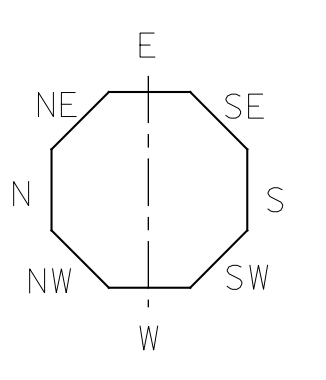

STATE OF NORTH CAROLINA
DEPARTMENT OF TRANSPORTATION
RALEIGH

BENT 101 & BENT 102

DRAWN BY: T. HARTLEY DATE: 2/2019
CHECKED BY: R. FISHER DATE: 3/2019



REVISIONS						SHEET NO.
NO.	BY:	DATE:	NO.	BY:	DATE:	TOTAL SHEETS
1			3			166
2			4			355

DOCUMENT NOT CONSIDERED FINAL UNLESS ALL SIGNATURES COMPLETED