

AS-BUILT REPAIR QUANTITY TABLE

BENT 71				
CAP REPAIRS				
SHOTCRETE REPAIRS	- SF	- CF	SF	CF
EPOXY RESIN INJECTION	- LF			LF
PILE REPAIRS				
PILE CONCRETE RESTORATION	16.0 SF	6.3 CF	SF	CF
FRP PROTECTIVE SYSTEM AWL	126.5 SF			
FRP PROTECTIVE SYSTEM BWL	49.5 SF			

BENT 72				
CAP REPAIRS				
SHOTCRETE REPAIRS	- SF	- CF	SF	CF
EPOXY RESIN INJECTION	- LF			LF
PILE REPAIRS				
PILE CONCRETE RESTORATION	33.8 SF	13.6 CF	SF	CF
FRP PROTECTIVE SYSTEM AWL	176.0 SF			
FRP PROTECTIVE SYSTEM BWL	66.0 SF			

FOR CAP REPAIRS: VALUES IN CHART REPRESENT ESTIMATED REPAIR TOTALS AFTER REMOVAL OF UNSOUND CONCRETE, MIN. OF 1" BEHIND REBAR AND MIN. 2" CL. TO SAWCUT. SEE REPAIR DETAILS.

NOTES:
REPAIR LOCATIONS AND ESTIMATE OF QUANTITIES ARE GIVEN WITH THE BEST INFORMATION AVAILABLE. IF ADDITIONAL REPAIRS NOT SHOWN ON THE DRAWINGS ARE DEEMED NECESSARY BY THE ENGINEER, THE CONTRACTOR SHALL NOTE ON THE DRAWINGS THE APPROXIMATE LOCATION AND DESCRIPTION OF THE REPAIRS AND ADJUST THE ACTUAL QUANTITIES ENTERED INTO THE REPAIR QUANTITY TABLE.

FOR SHOTCRETE REPAIRS, SEE SPECIAL PROVISIONS.
FOR CONCRETE REPAIR DETAILS, SEE "TYPICAL CAP, COLUMN & UNDERDECK REPAIR DETAILS" & "PILE CONCRETE RESTORATION DETAILS" SHEETS.
FOR PILE CONCRETE RESTORATION, SEE SPECIAL PROVISIONS.
FOR FRP PROTECTIVE SYSTEM, SEE SPECIAL PROVISIONS.
FOR FRP PROTECTIVE SYSTEM DETAILS AND UNDERWATER MORTAR REPAIRS, SEE "PILE FRP PROTECTIVE SYSTEM DETAILS" SHEET.

ESTIMATED PILE CRACK QTY. TABLE									
		NW	W	SW	S	SE	E	NE	N
BENT 71	PILE 1	-	-	-	-	2	-	5	-
	PILE 2	-	-	-	-	-	-	-	-
	PILE 3	-	6	-	6	6	-	-	-
	PILE 4	-	3	2	-	-	-	-	5
BENT 72	PILE 1	-	-	-	1	-	2	4	-
	PILE 2	-	-	8	6	-	6	-	4
	PILE 3	-	-	3	-	6	-	-	4
	PILE 4	-	-	3	-	-	-	-	5

NOTE: FOR INFORMATION ON PILE CONDITION ONLY.

PROJECT NO. HB-0017
DARE COUNTY
 BRIDGE NO. 270009

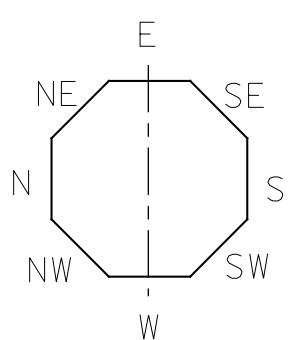

▲ FRP PROTECTIVE SYSTEM BELOW WATERLINE MAY INCLUDE APPROVED UNDERWATER MORTAR REPAIRS

- ERI - EPOXY RESIN INJECTION
- [Solid Grey Box] - FRP PROTECTIVE SYSTEM
- [Hatched Box] - PILE CONCRETE RESTORATION
- [Cross-hatched Box] - SHOTCRETE REPAIRS

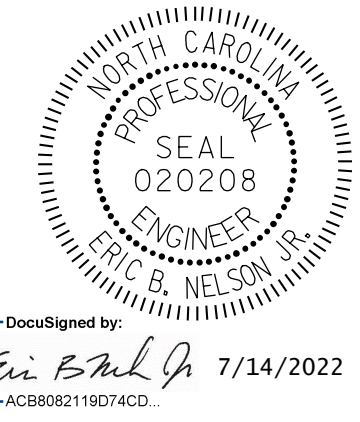

STATE OF NORTH CAROLINA
 DEPARTMENT OF TRANSPORTATION
 RALEIGH

BENT 71 & BENT 72

REVISIONS						SHEET NO.
NO.	BY:	DATE:	NO.	BY:	DATE:	TOTAL SHEETS
1			3			151
2			4			355

DOCUMENT NOT CONSIDERED FINAL UNLESS ALL SIGNATURES COMPLETED

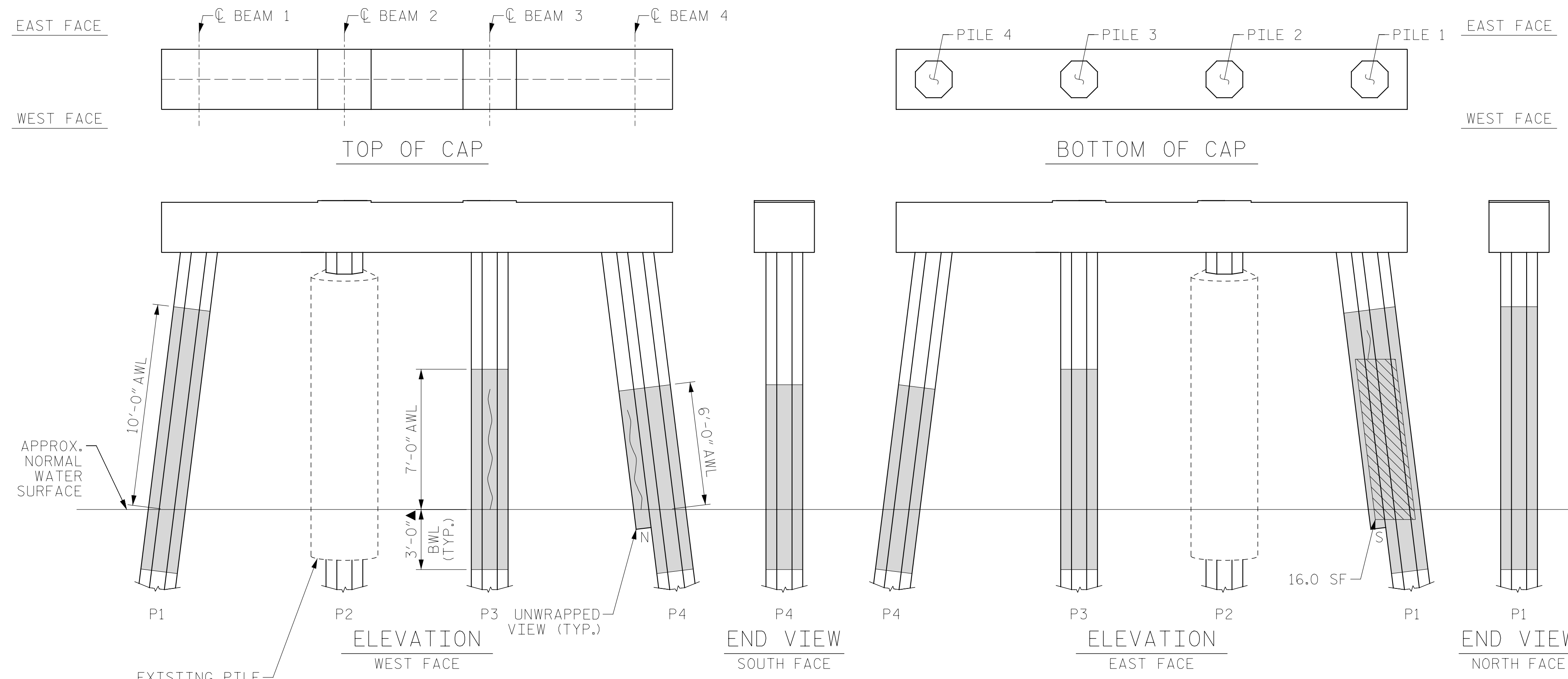

BENT 71

(AWL = ABOVE WATERLINE)
 (BWL = BELOW WATERLINE)
 (**QUANTITY INCLUDES ADJACENT REPAIRS)

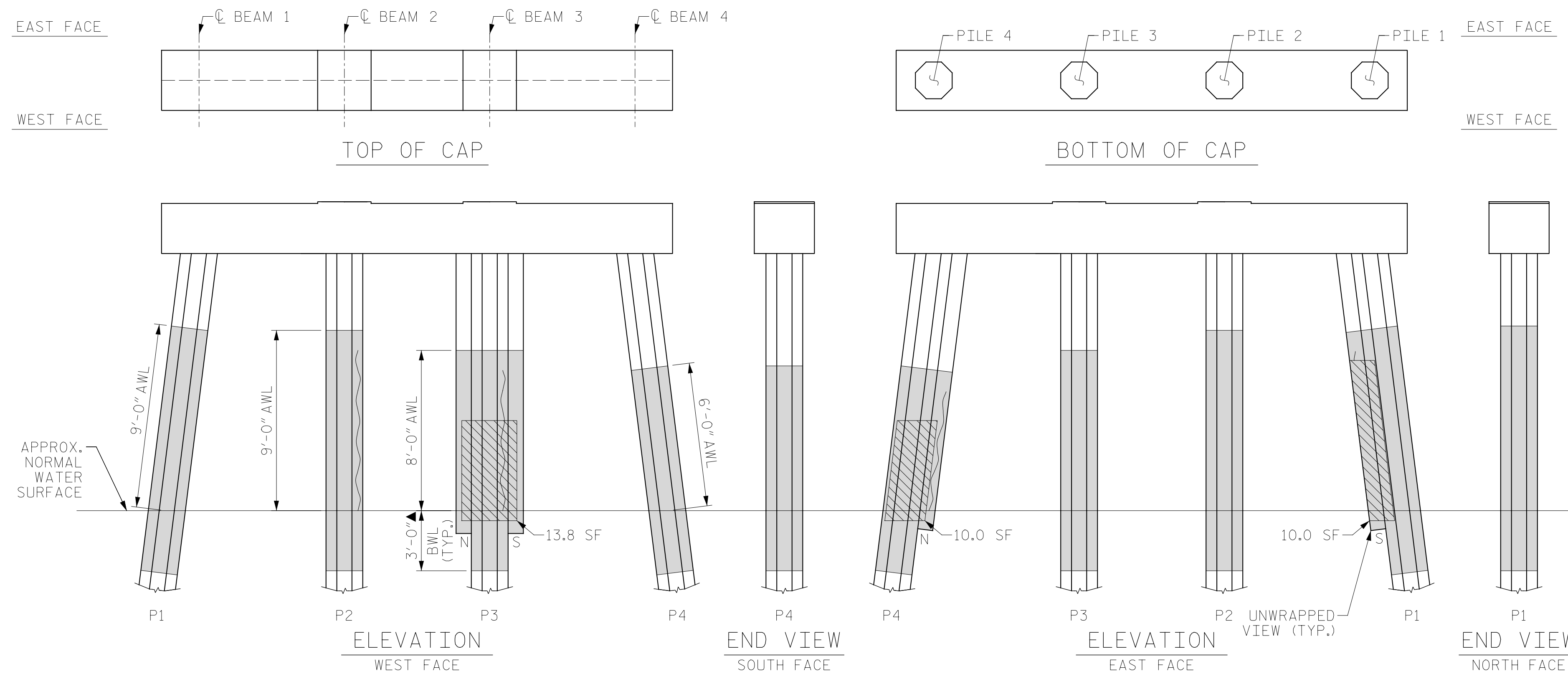

BENT 72

(AWL = ABOVE WATERLINE)
 (BWL = BELOW WATERLINE)
 (**QUANTITY INCLUDES ADJACENT REPAIRS)

DRAWN BY: T. HARTLEY DATE: 2/2019
 CHECKED BY: R. FISHER DATE: 3/2019