

AS-BUILT REPAIR QUANTITY TABLE

BENT 63

CAP REPAIRS			
SHOTCRETE REPAIRS	1.3 SF	0.7 CF	SF CF
EPOXY RESIN INJECTION	- LF		LF
PILE REPAIRS			
PILE CONCRETE RESTORATION	55.5 SF	21.4 CF	SF CF
FRP PROTECTIVE SYSTEM AWL	193.4 SF		
FRP PROTECTIVE SYSTEM BWL	66.0 SF		

BENT 64

CAP REPAIRS			
SHOTCRETE REPAIRS	- SF	- CF	SF CF
EPOXY RESIN INJECTION	- LF		LF
PILE REPAIRS			
PILE CONCRETE RESTORATION	34.0 SF	13.7 CF	SF CF
FRP PROTECTIVE SYSTEM AWL	121.5 SF		
FRP PROTECTIVE SYSTEM BWL	49.5 SF		

FOR CAP REPAIRS: VALUES IN CHART REPRESENT ESTIMATED REPAIR TOTALS AFTER REMOVAL OF UNSOUND CONCRETE, MIN. OF 1" BEHIND REBAR AND MIN. 2" CL. TO SAWCUT. SEE REPAIR DETAILS.

NOTES:

REPAIR LOCATIONS AND ESTIMATE OF QUANTITIES ARE GIVEN WITH THE BEST INFORMATION AVAILABLE. IF ADDITIONAL REPAIRS NOT SHOWN ON THE DRAWINGS ARE DEEMED NECESSARY BY THE ENGINEER, THE CONTRACTOR SHALL NOTE ON THE DRAWINGS THE APPROXIMATE LOCATION AND DESCRIPTION OF THE REPAIRS AND ADJUST THE ACTUAL QUANTITIES ENTERED INTO THE REPAIR QUANTITY TABLE.

FOR SHOTCRETE REPAIRS, SEE SPECIAL PROVISIONS.

FOR CONCRETE REPAIR DETAILS, SEE "TYPICAL CAP, COLUMN & UNDERDECK REPAIR DETAILS" & "PILE CONCRETE RESTORATION DETAILS" SHEETS.

FOR PILE CONCRETE RESTORATION, SEE SPECIAL PROVISIONS.

FOR FRP PROTECTIVE SYSTEM, SEE SPECIAL PROVISIONS.

FOR FRP PROTECTIVE SYSTEM DETAILS AND UNDERWATER MORTAR REPAIRS, SEE "PILE FRP PROTECTIVE SYSTEM DETAILS" SHEET.

		NW	W	SW	S	SE	E	NE	N
BENT 63	PILE 1	-	4	4	-	6	8	-	-
	PILE 2	-	5	7	-	7	5	-	-
	PILE 3	-	-	-	-	-	-	4	-
	PILE 4	6	-	-	-	-	-	6	6
BENT 64	PILE 1	-	-	-	-	-	-	-	-
	PILE 2	8	-	3	3	3	-	-	5
	PILE 3	3	-	4	-	-	-	-	5
	PILE 4	6	4	4	-	4	4	6	-

NOTE: FOR INFORMATION ON PILE CONDITION ONLY.

PROJECT NO. HB-0017  
DARE COUNTY  
 BRIDGE NO. 270009

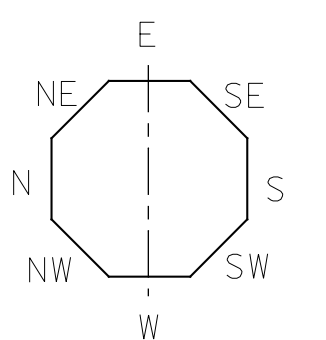

▲ FRP PROTECTIVE SYSTEM BELOW WATERLINE MAY INCLUDE APPROVED UNDERWATER MORTAR REPAIRS

- ERI - EPOXY RESIN INJECTION
- [Hatched Box] - FRP PROTECTIVE SYSTEM
- [Diagonal Lines Box] - PILE CONCRETE RESTORATION
- [Cross-hatched Box] - SHOTCRETE REPAIRS

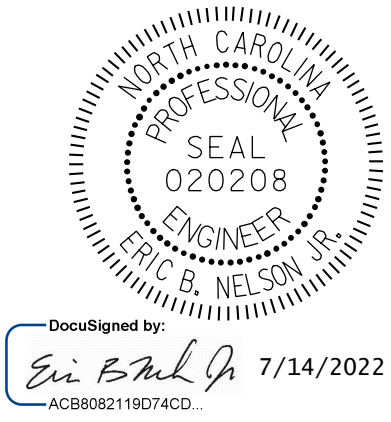

STATE OF NORTH CAROLINA  
 DEPARTMENT OF TRANSPORTATION  
 RALEIGH

BENT 63 & BENT 64

REVISIONS						SHEET NO.
NO.	BY:	DATE:	NO.	BY:	DATE:	S-147
1			3			TOTAL SHEETS
2			4			355

DOCUMENT NOT CONSIDERED FINAL UNLESS ALL SIGNATURES COMPLETED

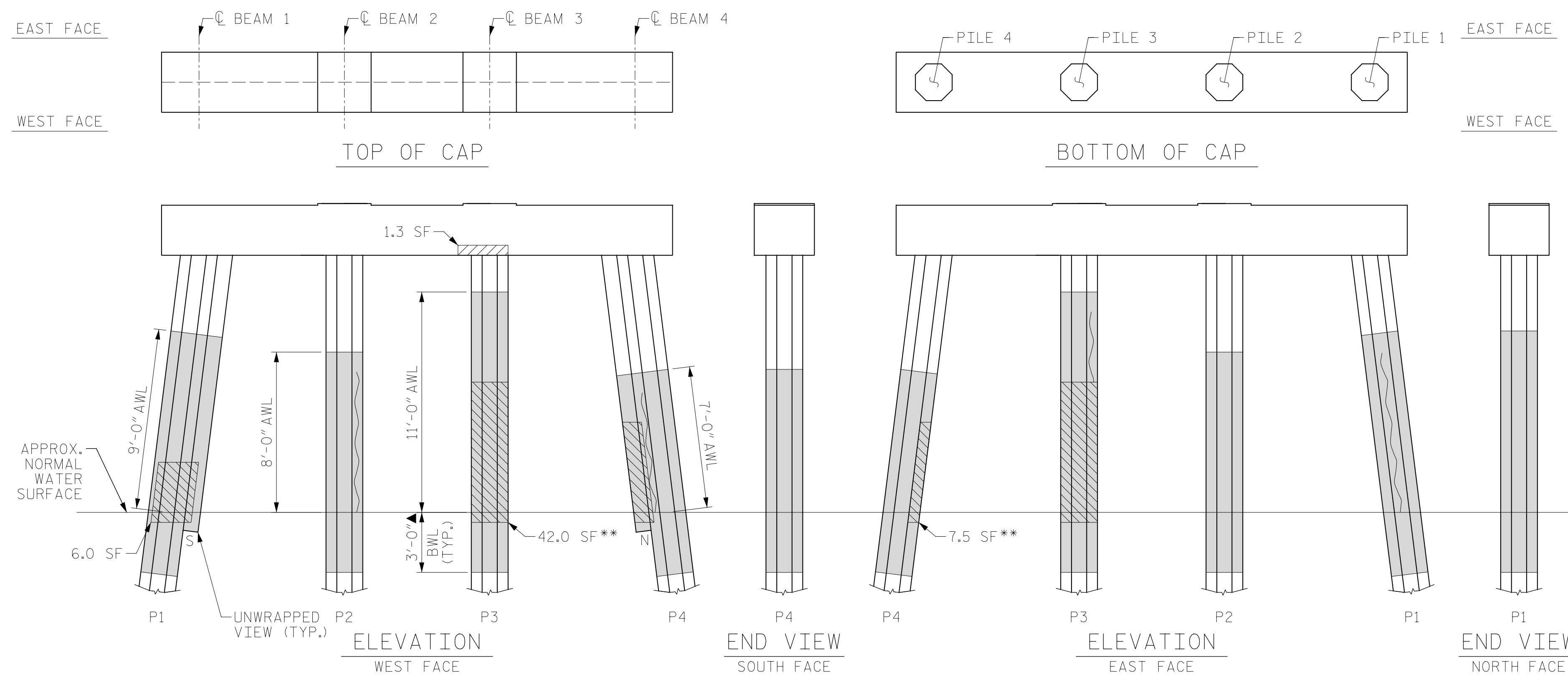

BENT 63

(AWL = ABOVE WATERLINE)  
 (BWL = BELOW WATERLINE)  
 (\*\*QUANTITY INCLUDES ADJACENT REPAIRS)

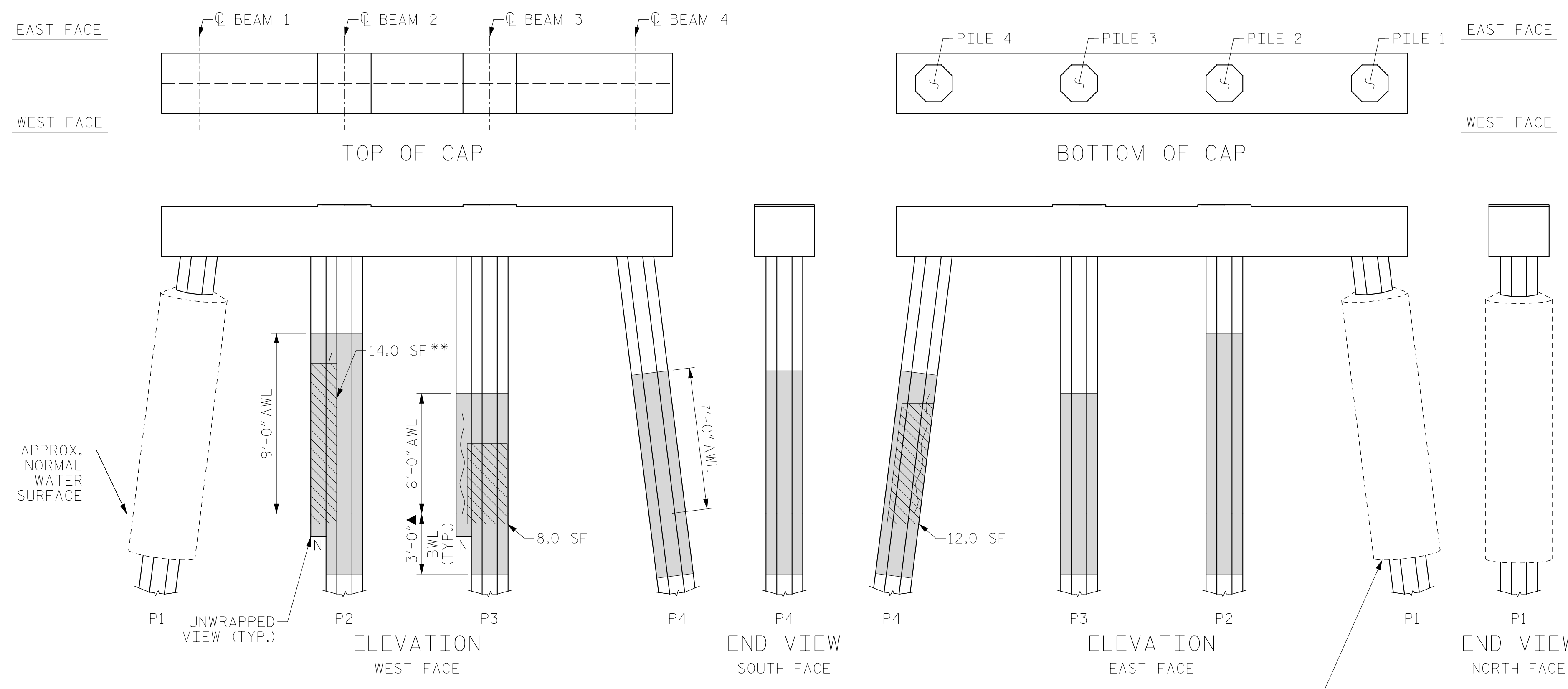

BENT 64

(AWL = ABOVE WATERLINE)  
 (BWL = BELOW WATERLINE)  
 (\*\*QUANTITY INCLUDES ADJACENT REPAIRS)

EXISTING PILE JACKET TO REMAIN (TYP.)

DRAWN BY: T. HARTLEY DATE: 2/2019  
 CHECKED BY: R. FISHER DATE: 3/2019