

AS-BUILT REPAIR QUANTITY TABLE

BENT 11			
CAP REPAIRS		ESTIMATE	
SHOTCRETE REPAIRS	0.6 SF	0.3 CF	SF CF
EPOXY RESIN INJECTION	- LF		LF
PILE REPAIRS		ESTIMATE	
PILE CONCRETE RESTORATION	18.4 SF	8.1 CF	SF CF
FRP PROTECTIVE SYSTEM AWL	146.7 SF		
FRP PROTECTIVE SYSTEM BWL	66.0 SF		

BENT 12			
CAP REPAIRS		ESTIMATE	
SHOTCRETE REPAIRS	- SF	- CF	SF CF
EPOXY RESIN INJECTION	- LF		LF
PILE REPAIRS		ESTIMATE	
PILE CONCRETE RESTORATION	10.6 SF	4.0 CF	SF CF
FRP PROTECTIVE SYSTEM AWL	149.4 SF		
FRP PROTECTIVE SYSTEM BWL	66.0 SF		

FOR CAP REPAIRS: VALUES IN CHART REPRESENT ESTIMATED REPAIR TOTALS AFTER REMOVAL OF UNSOUND CONCRETE, MIN. OF 1" BEHIND REBAR AND MIN. 2" CL. TO SAWCUT. SEE REPAIR DETAILS.

NOTES:  
REPAIR LOCATIONS AND ESTIMATE OF QUANTITIES ARE GIVEN WITH THE BEST INFORMATION AVAILABLE. IF ADDITIONAL REPAIRS NOT SHOWN ON THE DRAWINGS ARE DEEMED NECESSARY BY THE ENGINEER, THE CONTRACTOR SHALL NOTE ON THE DRAWINGS THE APPROXIMATE LOCATION AND DESCRIPTION OF THE REPAIRS AND ADJUST THE ACTUAL QUANTITIES ENTERED INTO THE REPAIR QUANTITY TABLE.

FOR SHOTCRETE REPAIRS, SEE SPECIAL PROVISIONS.  
FOR CONCRETE REPAIR DETAILS, SEE "TYPICAL CAP, COLUMN & UNDERDECK REPAIR DETAILS" & "PILE CONCRETE RESTORATION DETAILS" SHEETS.  
FOR PILE CONCRETE RESTORATION, SEE SPECIAL PROVISIONS.  
FOR FRP PROTECTIVE SYSTEM, SEE SPECIAL PROVISIONS.  
FOR FRP PROTECTIVE SYSTEM DETAILS AND UNDERWATER MORTAR REPAIRS, SEE "PILE FRP PROTECTIVE SYSTEM DETAILS" SHEET.

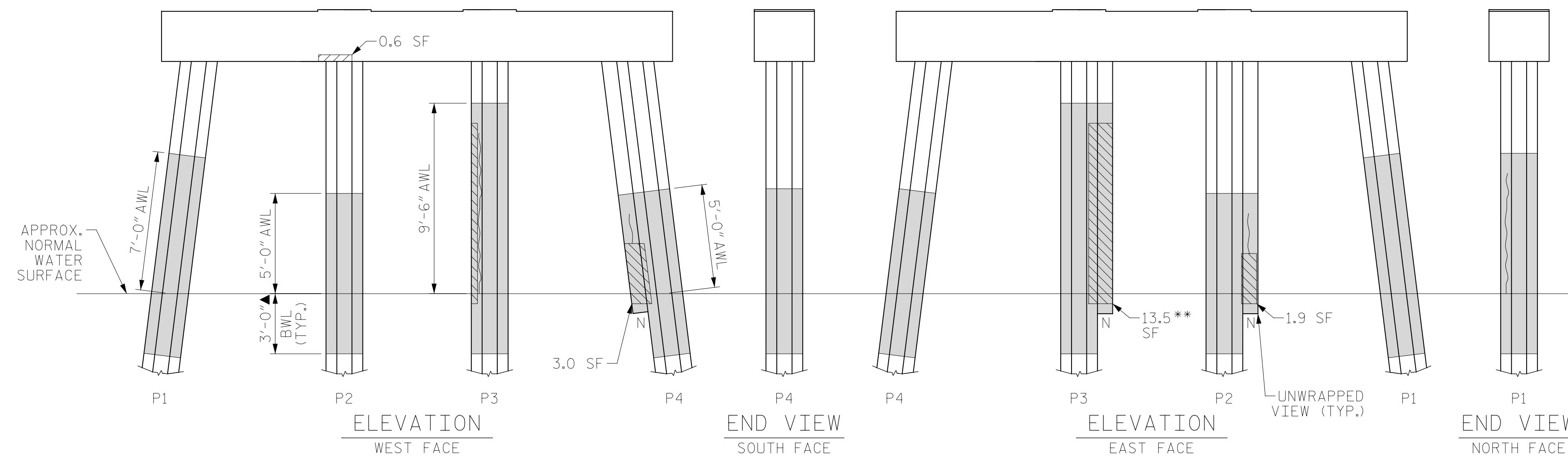
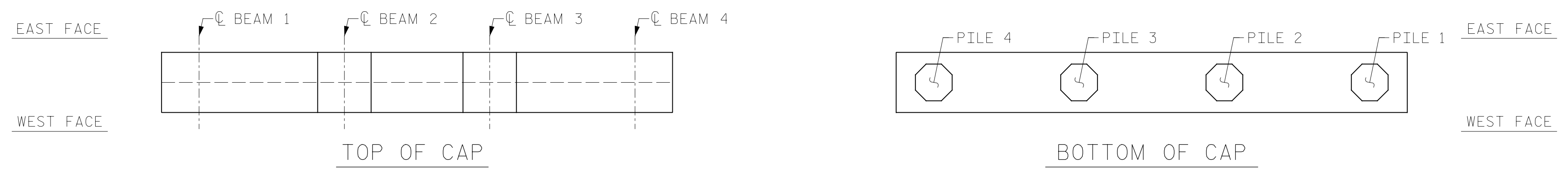

BENT 11

(AWL = ABOVE WATERLINE)  
(BWL = BELOW WATERLINE)  
(\*QUANTITY INCLUDES ADJACENT REPAIRS)

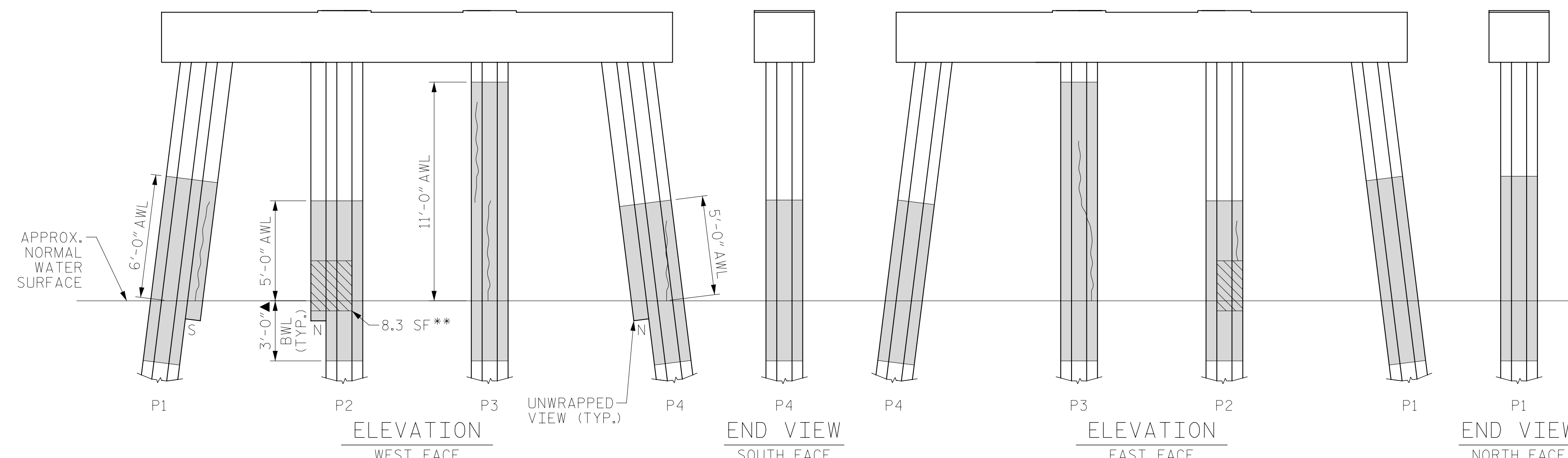
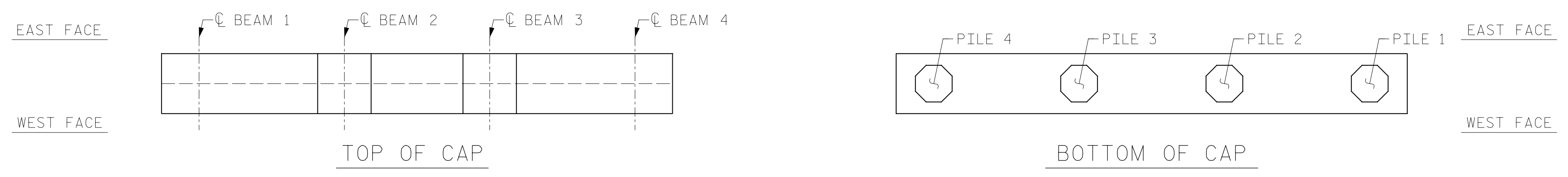

BENT 12

(AWL = ABOVE WATERLINE)  
(BWL = BELOW WATERLINE)  
(\*QUANTITY INCLUDES ADJACENT REPAIRS)

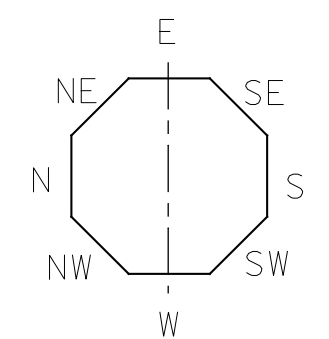

ESTIMATED PILE CRACK QTY.									
		NW	W	SW	S	SE	E	NE	N
BENT 11	PILE 1	-	-	-	-	-	6	6	-
	PILE 2	-	-	-	-	-	-	-	2.5
	PILE 3	8	-	-	-	-	-	-	-
	PILE 4	-	-	-	-	-	-	-	2
BENT 12	PILE 1	-	5	3	5	-	-	-	-
	PILE 2	-	-	-	-	-	-	2	-
	PILE 3	5	5	-	-	-	4	4	-
	PILE 4	2	2	2	-	-	-	-	2

NOTE: FOR INFORMATION ON PILE CONDITION ONLY.

PROJECT NO. HB-0017  
DARE COUNTY  
BRIDGE NO. 270009

- ▲ FRP PROTECTIVE SYSTEM BELOW WATERLINE MAY INCLUDE APPROVED UNDERWATER MORTAR REPAIRS
- ERI - EPOXY RESIN INJECTION
- [Hatched Box] - FRP PROTECTIVE SYSTEM
- [Diagonal Lines] - PILE CONCRETE RESTORATION
- [Cross-hatched Box] - SHOTCRETE REPAIRS



STATE OF NORTH CAROLINA  
DEPARTMENT OF TRANSPORTATION  
RALEIGH  
  
BENT 11 & BENT 12

DRAWN BY: T. HARTLEY DATE: 2/2019  
CHECKED BY: R. WERTMAN DATE: 3/2019



DOCUMENT NOT CONSIDERED FINAL UNLESS ALL SIGNATURES COMPLETED

REVISIONS						SHEET NO.
NO.	BY:	DATE:	NO.	BY:	DATE:	TOTAL SHEETS
1			3			121
2			4			355