

AS-BUILT REPAIR QUANTITY TABLE

BENT 5

CAP REPAIRS		ESTIMATE			
SHOTCRETE REPAIRS	8.3 SF	4.2 CF	SF	CF	
EPOXY RESIN INJECTION	- LF				LF
PILE REPAIRS		ESTIMATE			
PILE CONCRETE RESTORATION	41.3 SF	17.5 CF	SF	CF	
FRP PROTECTIVE SYSTEM AWL	173.7 SF				
FRP PROTECTIVE SYSTEM BWL	99.0 SF				

BENT 6

CAP REPAIRS		ESTIMATE			
SHOTCRETE REPAIRS	11.8 SF	5.9 SF	SF	CF	
EPOXY RESIN INJECTION	- LF				LF
PILE REPAIRS		ESTIMATE			
PILE CONCRETE RESTORATION	25.0 SF	10.1 CF	SF	CF	
FRP PROTECTIVE SYSTEM AWL	137.0 SF				
FRP PROTECTIVE SYSTEM BWL	66.0 SF				

FOR CAP REPAIRS: VALUES IN CHART REPRESENT ESTIMATED REPAIR TOTALS AFTER REMOVAL OF UNSOUND CONCRETE, MIN. OF 1" BEHIND REBAR AND MIN. 2" CL. TO SAWCUT. SEE REPAIR DETAILS.

NOTES:
REPAIR LOCATIONS AND ESTIMATE OF QUANTITIES ARE GIVEN WITH THE BEST INFORMATION AVAILABLE. IF ADDITIONAL REPAIRS NOT SHOWN ON THE DRAWINGS ARE DEEMED NECESSARY BY THE ENGINEER, THE CONTRACTOR SHALL NOTE ON THE DRAWINGS THE APPROXIMATE LOCATION AND DESCRIPTION OF THE REPAIRS AND ADJUST THE ACTUAL QUANTITIES ENTERED INTO THE REPAIR QUANTITY TABLE.

FOR SHOTCRETE REPAIRS, SEE SPECIAL PROVISIONS.
FOR CONCRETE REPAIR DETAILS, SEE "TYPICAL CAP, COLUMN & UNDERDECK REPAIR DETAILS" & "PILE CONCRETE RESTORATION DETAILS" SHEETS.
FOR PILE CONCRETE RESTORATION, SEE SPECIAL PROVISIONS.
FOR FRP PROTECTIVE SYSTEM, SEE SPECIAL PROVISIONS.
FOR FRP PROTECTIVE SYSTEM DETAILS AND UNDERWATER MORTAR REPAIRS, SEE "PILE FRP PROTECTIVE SYSTEM DETAILS" SHEET.

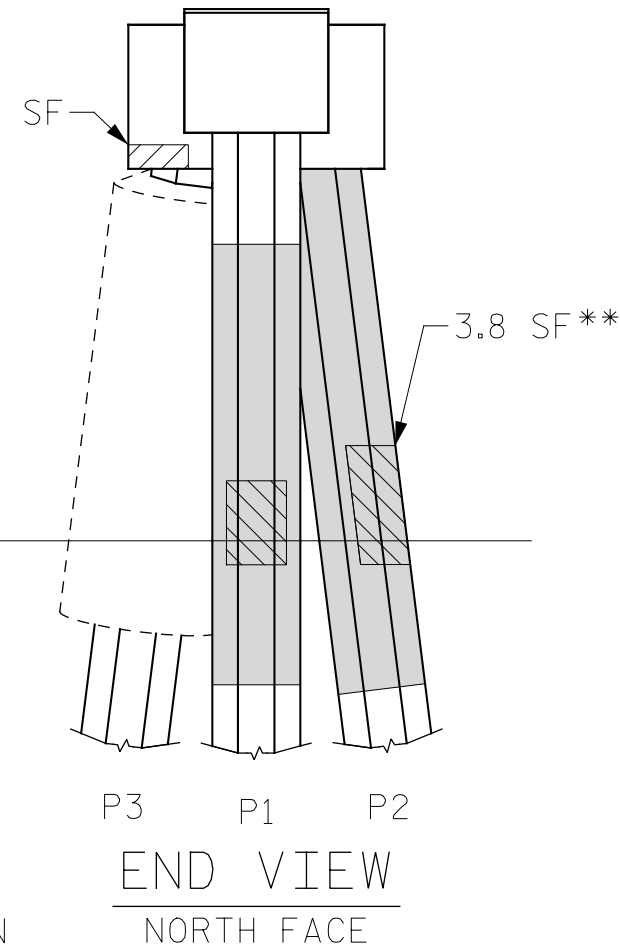
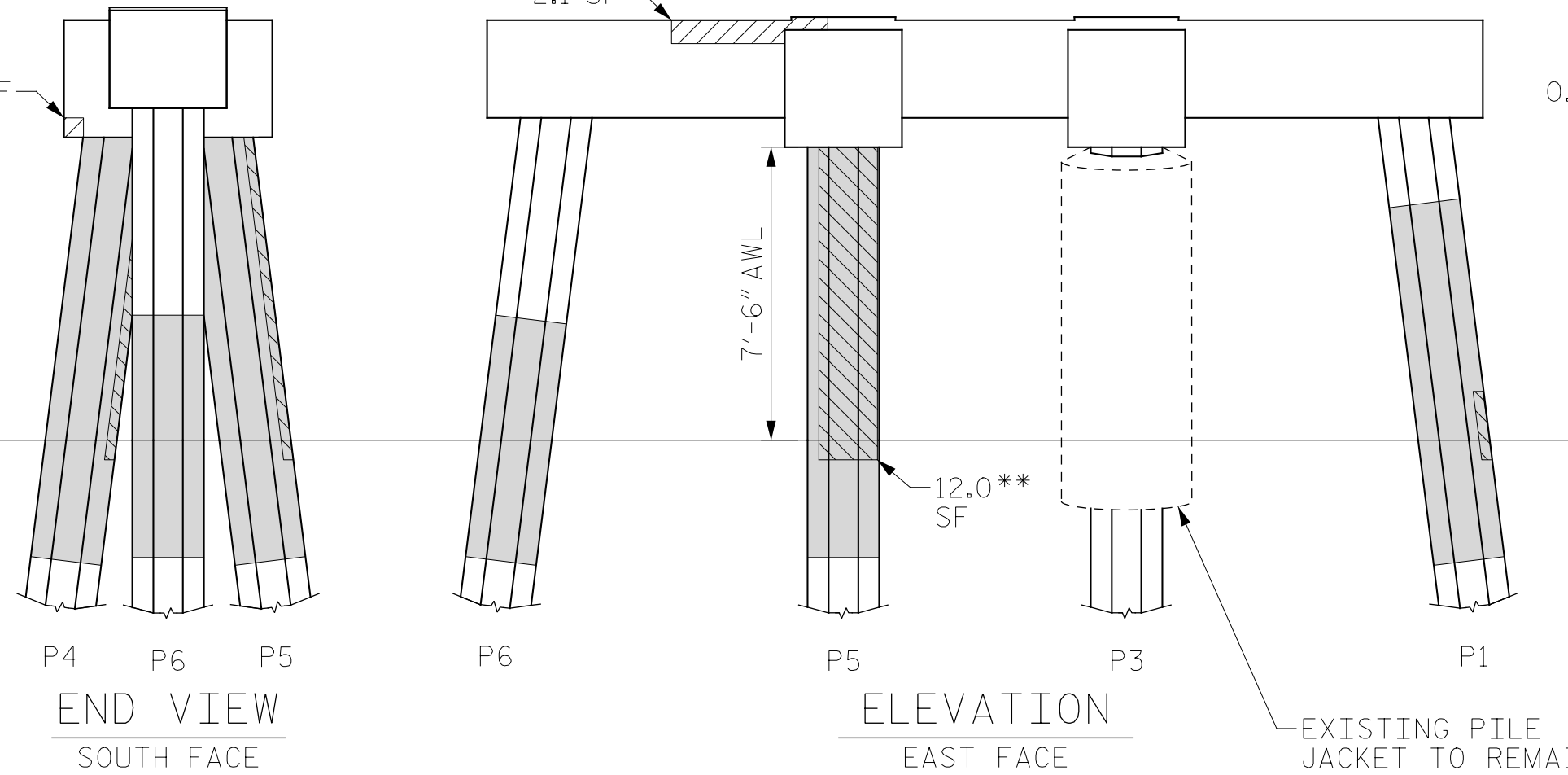
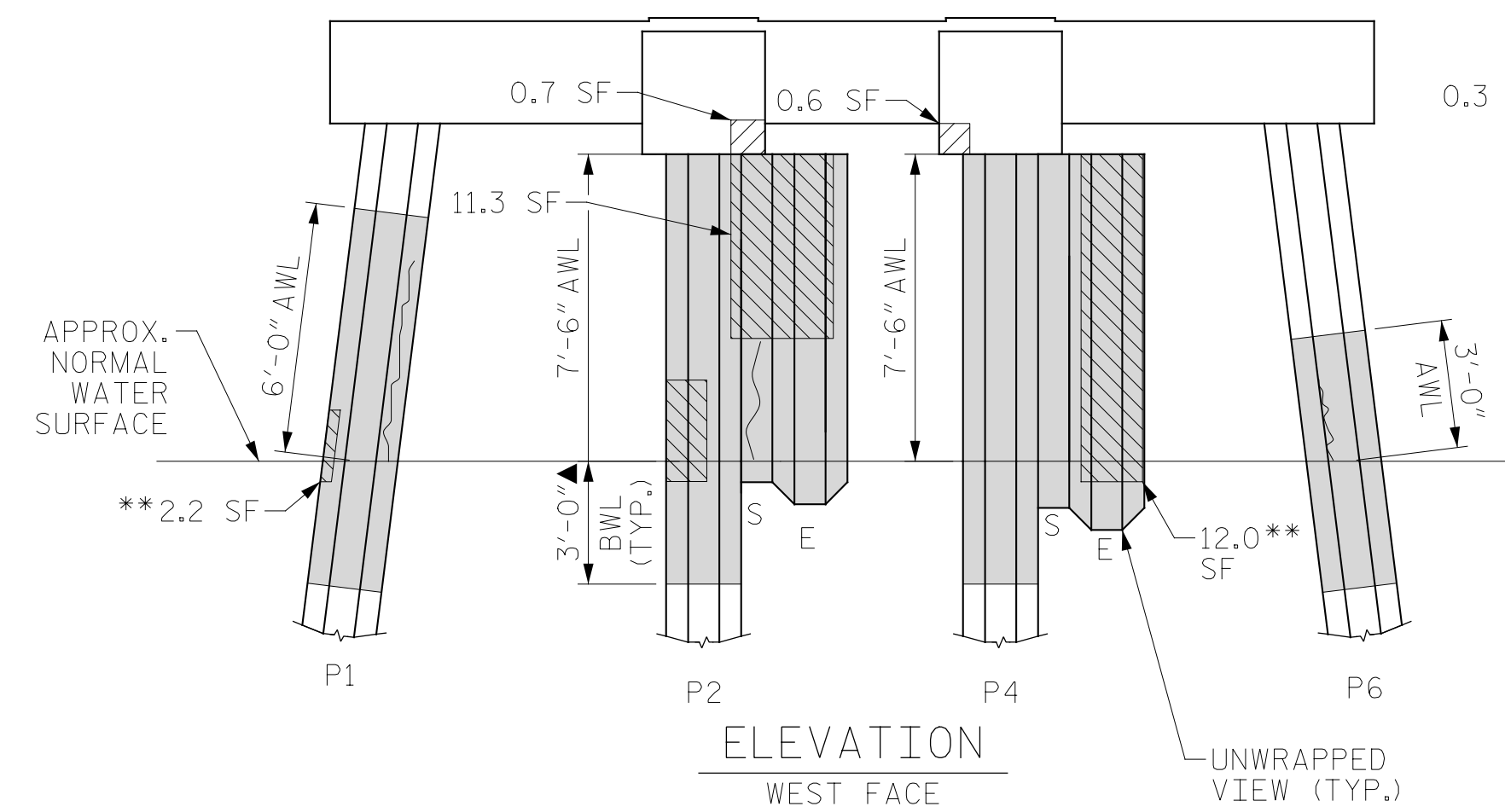
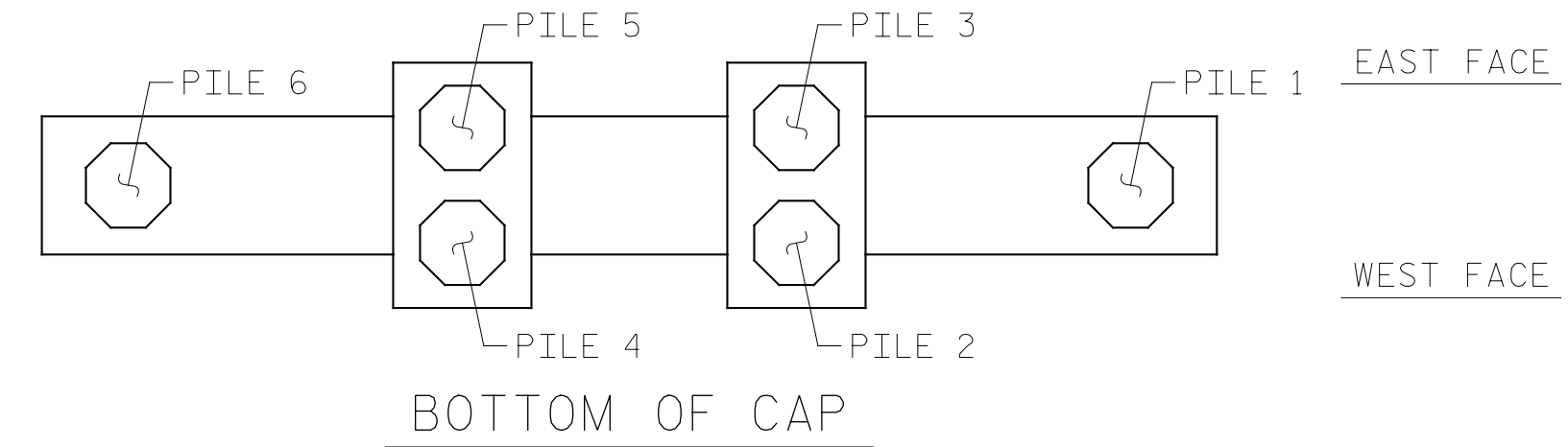
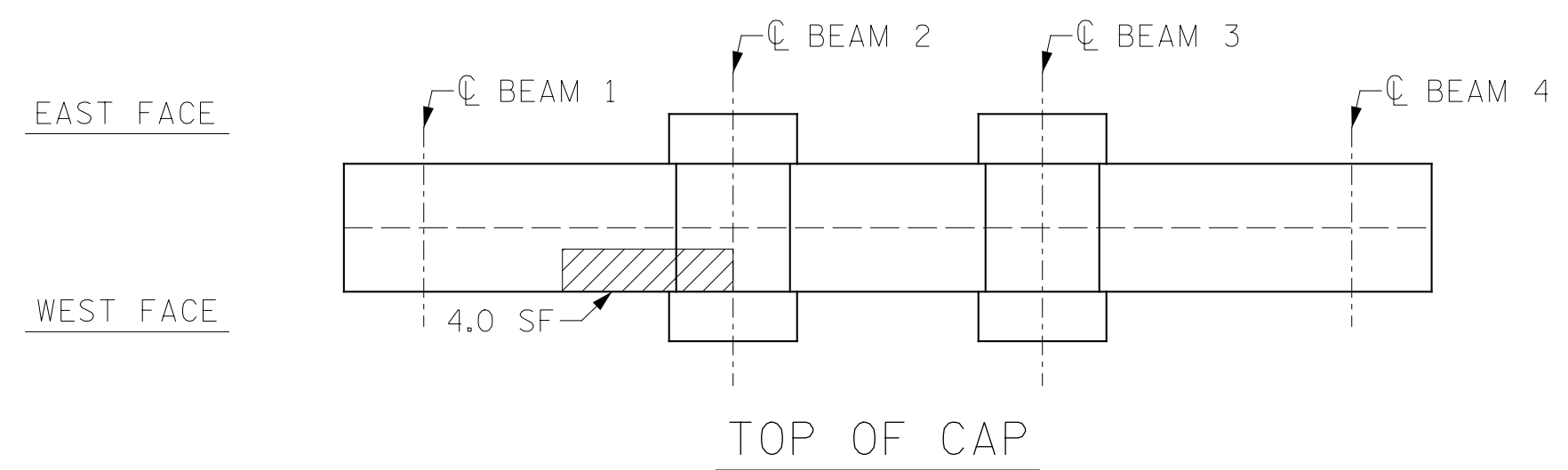

BENT 5

(AWL = ABOVE WATERLINE)
(BWL = BELOW WATERLINE)
(**QUANTITY INCLUDES ADJACENT REPAIRS)

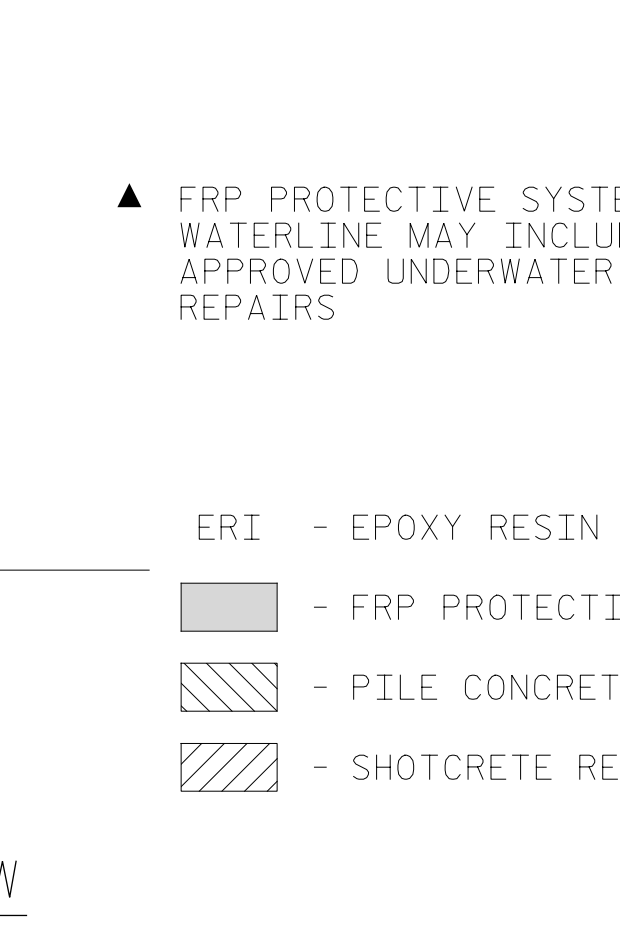
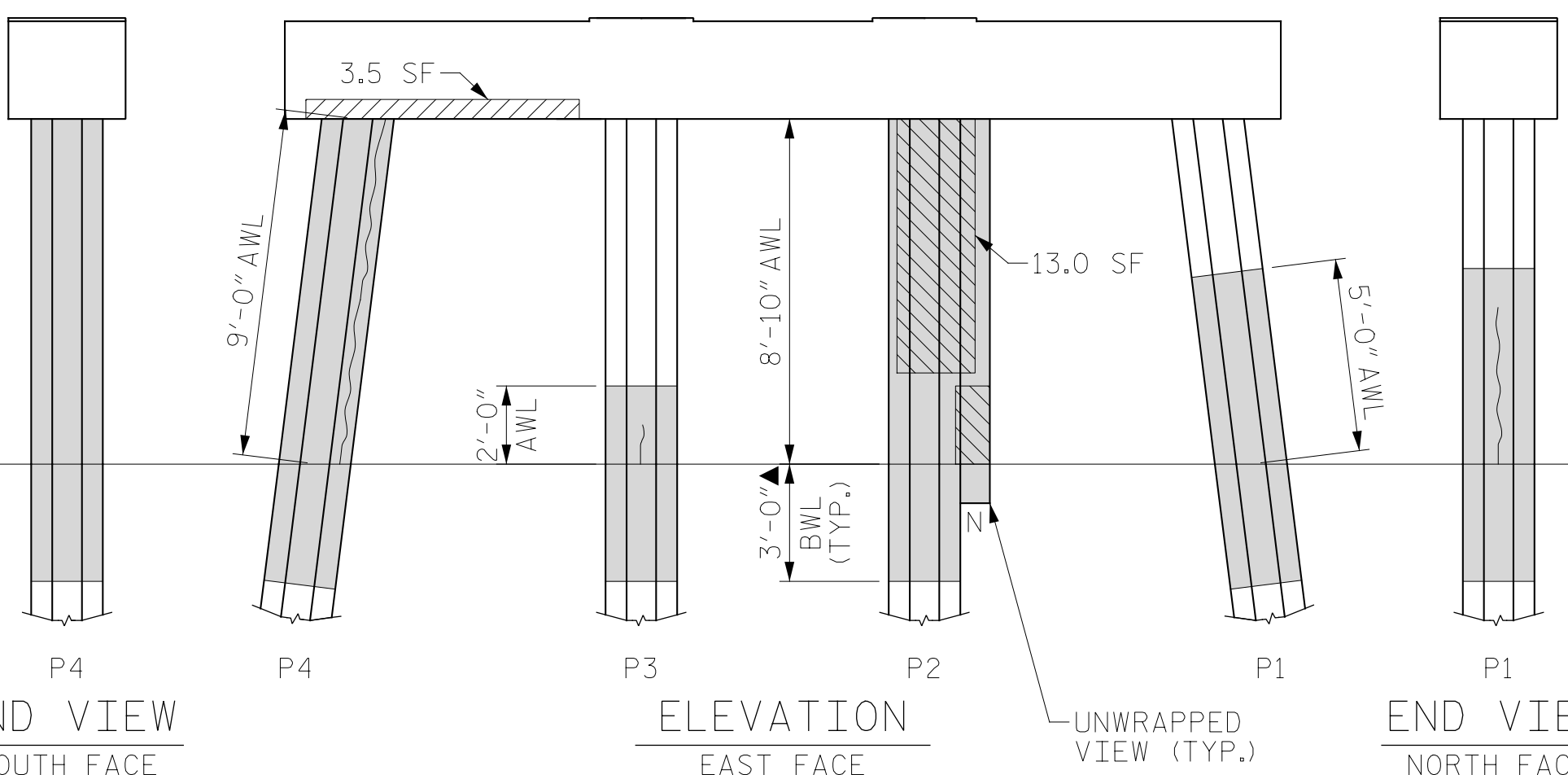
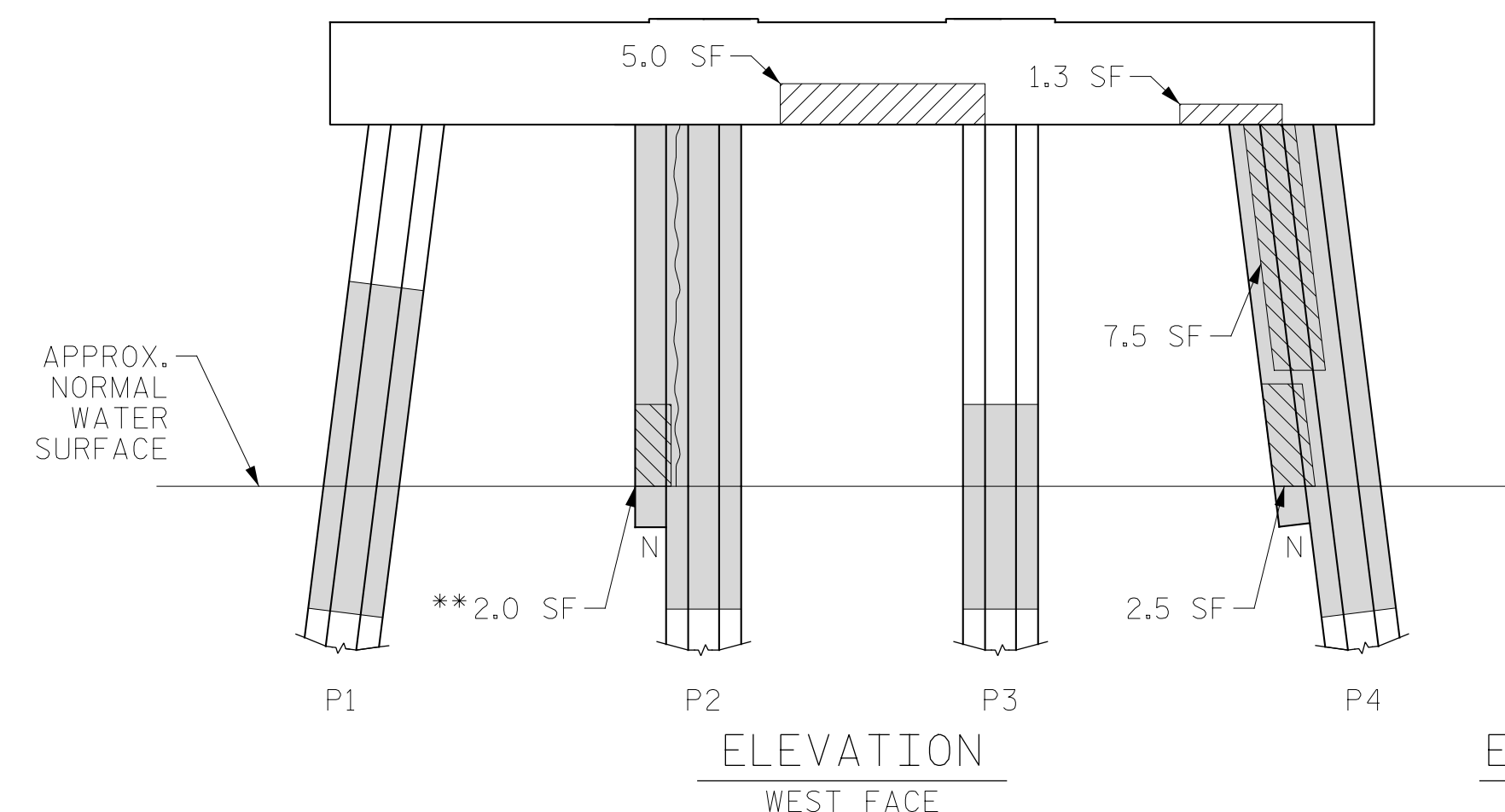
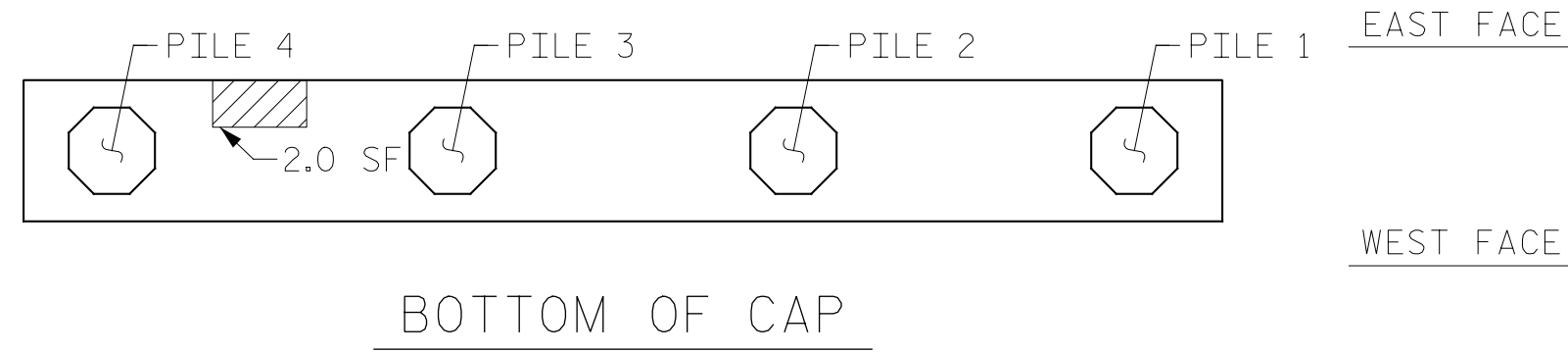
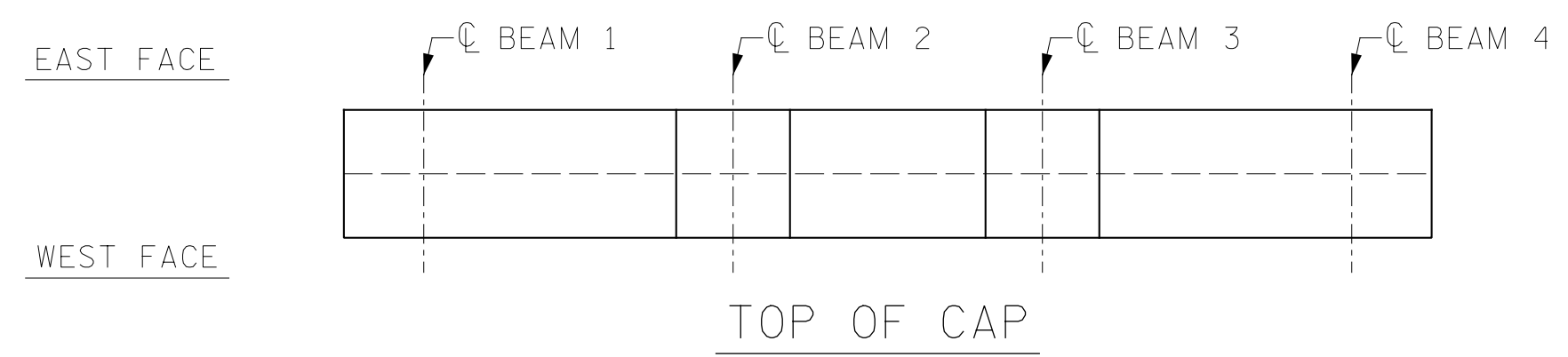

BENT 6

(AWL = ABOVE WATERLINE)
(BWL = BELOW WATERLINE)
(**QUANTITY INCLUDES ADJACENT REPAIRS)

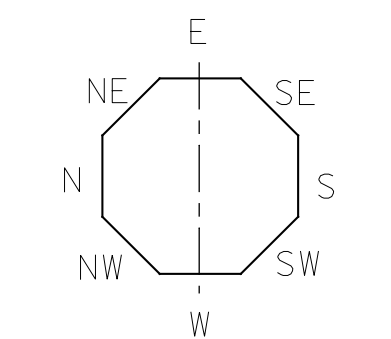

ESTIMATED PILE CRACK QTY.			NW	W	SW	S	SE	E	NE	N
BENT 5	PILE 1	-	-	5	-	-	5	-	-	-
	PILE 2	-	-	-	3	-	-	-	-	-
	PILE 3	-	-	-	-	-	-	-	-	-
	PILE 4	-	-	-	-	-	-	-	-	7.5
	PILE 6	-	2	-	-	-	-	-	-	-
BENT 6	PILE 1	-	-	-	-	-	-	-	-	4
	PILE 2	9	-	-	-	-	-	-	-	-
	PILE 3	-	-	-	-	-	1	-	-	-
	PILE 4	4	-	-	-	-	-	-	9	-

NOTE: FOR INFORMATION ON PILE CONDITION ONLY.

PROJECT NO. HB-0017
DARE COUNTY
BRIDGE NO. 270009

- ▲ FRP PROTECTIVE SYSTEM BELOW WATERLINE MAY INCLUDE APPROVED UNDERWATER MORTAR REPAIRS
- ERI - EPOXY RESIN INJECTION
- FRP PROTECTIVE SYSTEM
- PILE CONCRETE RESTORATION
- SHOTCRETE REPAIRS

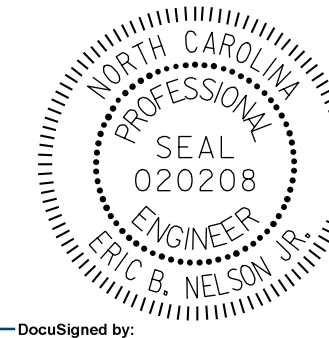

DocuSigned by: Eric B. Nelson 7/14/2022

STATE OF NORTH CAROLINA
DEPARTMENT OF TRANSPORTATION
RALEIGH

BENT 5 & BENT 6

DRAWN BY: T. HARTLEY DATE: 2/2019
CHECKED BY: R. WERTMAN DATE: 3/2019



REVISIONS						SHEET NO.
NO.	BY:	DATE:	NO.	BY:	DATE:	S-118
1			3			TOTAL SHEETS
2			4			355

DOCUMENT NOT CONSIDERED FINAL UNLESS ALL SIGNATURES COMPLETED