

**This electronic collection of documents is provided
for the convenience of the user
and is Not a Certified Document –**

**The documents contained herein were originally issued
and sealed by the individuals whose names and license
numbers appear on each page, on the dates appearing
with their signature on that page.**

**This file or an individual page
shall not be considered a certified document.**

STATE OF NORTH CAROLINA
DIVISION OF HIGHWAYS

TRANSPORTATION MANAGEMENT PLAN

LEE COUNTY

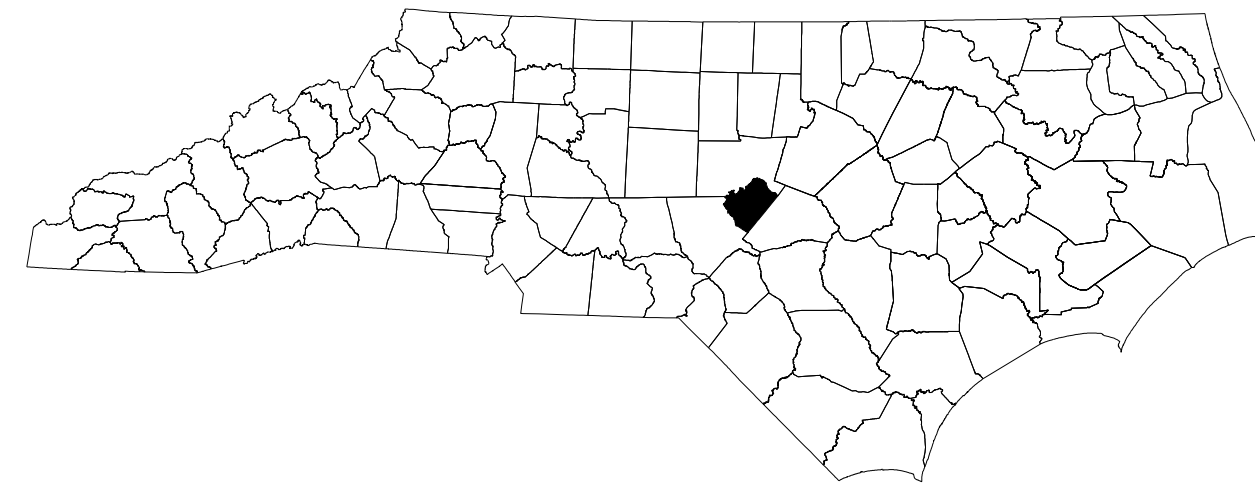

LOCATION: NC 42 FROM US 421 TO SR 1579 (MAIN STREET) IN SANFORD AND ALONG SR 1579 FROM NC 42 TO SR 1538 (E. HARRINGTON AVE) IN BROADWAY

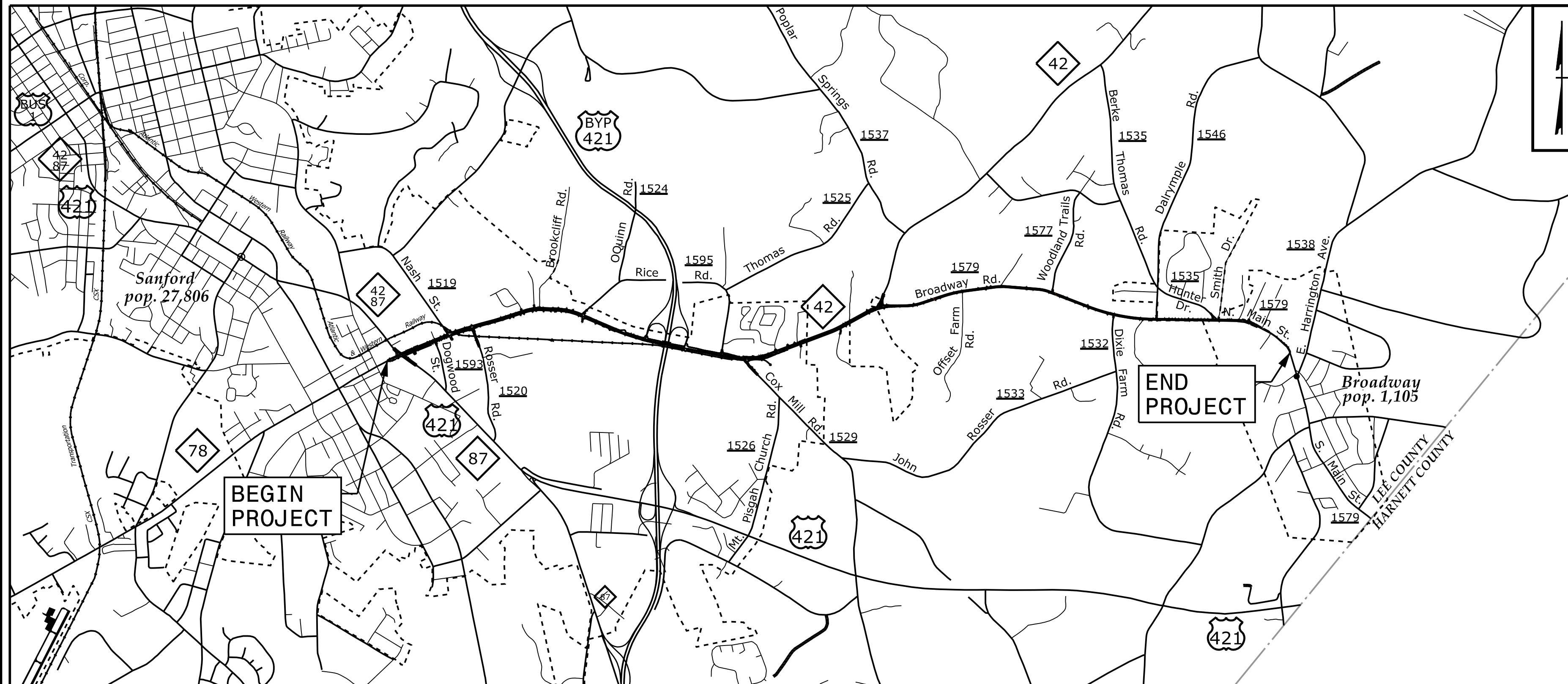

PLAN PREPARED BY:
HDR HDR Engineering, Inc. of the Carolinas
555 Fayetteville St, Suite 900 Raleigh, N.C. 27601
N.C.B.E.L.S. License Number: F-0116

**DOCUMENT NOT CONSIDERED FINAL
UNLESS ALL SIGNATURES COMPLETED**

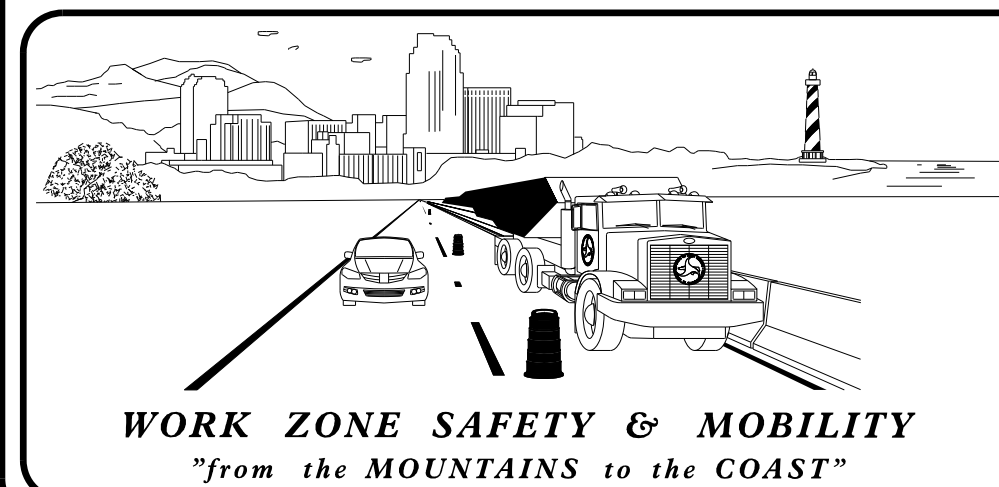

PLANS PREPARED BY:

MIKE RZEPKA, P.E.
TRAFFIC CONTROL PROJECT ENGINEER

ZHUOJIN WANG, P.E.
TRAFFIC CONTROL DESIGN ENGINEER

NC DOT CONTACTS:

KEN THORNWELL, P.E.
PROJECT ENGINEER

JUSTIN BEAVER, P.E.
PROJECT DESIGN ENGINEER

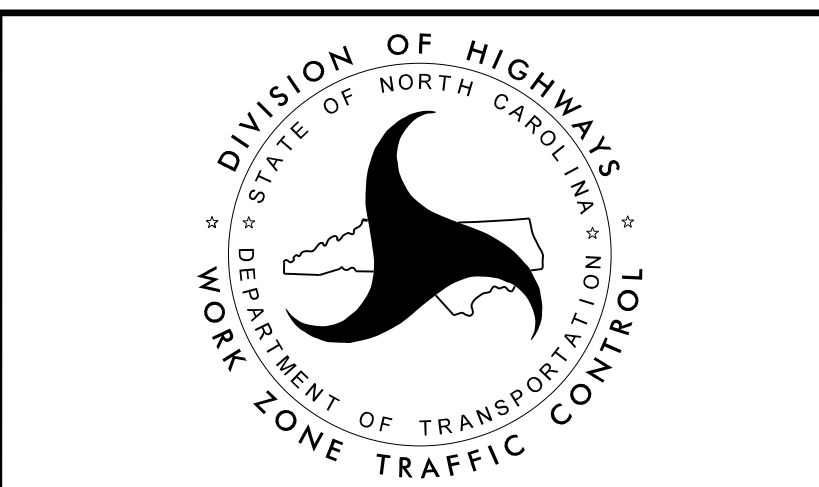

APPROVED: Michael T. Rzepka
DATE: 7/12/2022

SEAL

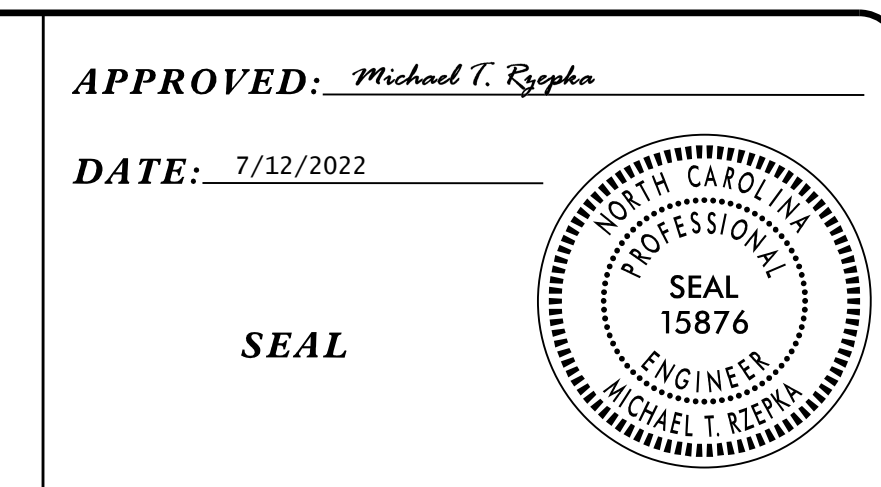

SHEET NO.	TITLE
TMP-1	TITLE SHEET, VICINITY MAP, AND INDEX OF SHEETS
TMP-1A	LIST OF APPLICABLE ROADWAY STANDARD DRAWINGS, AND LEGEND
TMP-1B AND 1C	TRANSPORTATION OPERATIONS PLAN: (MANAGEMENT STRATEGIES, GENERAL NOTES, AND LOCAL NOTES)
TMP-2	PORTABLE CONCRETE BARRIER AT TEMPORARY SHORING LOCATIONS
TMP-2A	TEMPORARY SHORING DATA
TMP-2B	DETOUR ROUTE FOR COX MILL RD. CLOSURE
TMP-2C	DETOUR ROUTE FOR BROADWAY RD. CLOSURE
TMP-2D	SPECIAL SIGN DESIGN(S)
TMP-3	TEMPORARY TRAFFIC CONTROL PHASING
TMP-4.01 THRU 4.24	TEMPORARY TRAFFIC CONTROL PHASE 1 STEP 1 DETAILS
TMP-4.25 THRU 4.27	TEMPORARY TRAFFIC CONTROL PHASE 1 STEP 1A DETAILS
TMP-5.01 THRU 5.02	TEMPORARY TRAFFIC CONTROL PHASE 1 STEP 2 DETAILS
TMP-6.01 THRU 6.14	TEMPORARY TRAFFIC CONTROL PHASE 2 DETAILS
TMP-7.01 THRU 7.22	TEMPORARY TRAFFIC CONTROL PHASE 3 DETAILS

PLOT DRIVER: NCDOT.pdf_color_eng_50.ppt
 USER: CHARNDEN
 FILE: p:\nhdr\users\01\HDR_US_East_01\Documents\3322\1002133\10279033\5.0_CAD_BIM\6.2_WIP_TrafficControl\TCP\R3830_TC_TMP-01.dgn
 PENTABLE: NCDOT_tcp.tbl
 TIME: 11:07:00 AM
 DATE: 5/4/2022







ROADWAY STANDARD DRAWINGS

THE FOLLOWING ROADWAY STANDARDS AS SHOWN IN "ROADWAY STANDARD DRAWINGS" - N.C. DEPARTMENT OF TRANSPORTATION - RALEIGH, N.C., DATED JANUARY 2018 ARE APPLICABLE TO THIS PROJECT AND BY REFERENCE HEREBY ARE CONSIDERED A PART OF THESE PLANS:

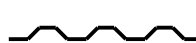

STD. NO.	TITLE
1101.01	WORK ZONE ADVANCE WARNING SIGNS
1101.02	TEMPORARY LANE CLOSURES
1101.03	TEMPORARY ROAD CLOSURES
1101.04	TEMPORARY SHOULDER CLOSURES
1101.05	WORK ZONE VEHICLE ACCESSES
1101.11	TRAFFIC CONTROL DESIGN TABLES
1110.01	STATIONARY WORK ZONE SIGNS
1110.02	PORTABLE WORK ZONE SIGNS
1115.01	FLASHING ARROW BOARDS
1130.01	DRUMS
1135.01	CONES
1145.01	BARRICADES
1150.01	FLAGGERS
1160.01	TEMPORARY CRASH CUSHION
1165.01	TRUCK MOUNTED ATTENUATOR
1170.01	PORTABLE CONCRETE BARRIER
1180.01	SKINNY-DRUMS
1205.01	PAVEMENT MARKINGS - LINE TYPES AND OFFSETS
1205.02	PAVEMENT MARKINGS - TWO-LANE AND MULTI-LANE ROADWAYS
1205.04	PAVEMENT MARKINGS - INTERSECTIONS
1205.05	PAVEMENT MARKINGS - TURN LANES
1205.06	PAVEMENT MARKINGS - LANE DROPS
1205.07	PAVEMENT MARKINGS - PEDESTRIAN CROSSWALKS
1205.08	PAVEMENT MARKINGS - SYMBOLS AND WORD MESSAGES
1205.09	PAVEMENT MARKINGS - PAINTED ISLANDS
1205.10	PAVEMENT MARKINGS - SCHOOL AREAS
1205.13	PAVEMENT MARKINGS - LANE REDUCTIONS
1205.15	PAVEMENT MARKINGS - SUPERSTREETS
1250.01	RAISED PAVEMENT MARKERS - INSTALLATION SPACING
1251.01	RAISED PAVEMENT MARKERS - PERMANENT AND TEMPORARY
1261.01	GUARDRAIL AND BARRIER DELINEATORS - INSTALLATION SPACING
1261.02	GUARDRAIL AND BARRIER DELINEATORS - TYPES AND MOUNTING
1262.01	GUARDRAIL END DELINEATION

LEGEND

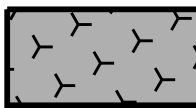
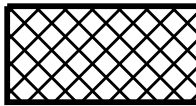
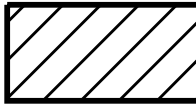
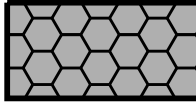
GENERAL

-  DIRECTION OF TRAFFIC FLOW
-  DIRECTION OF PEDESTRIAN TRAFFIC FLOW
-  EXIST. PVMT.
-  NORTH ARROW
-  PROPOSED PVMT.
-  TEMP. SHORING (LOCATION PURPOSES ONLY)
-  WORK AREA
-  CONTINUING CONSTRUCTION
-  REMOVAL
-  WEDGING
-  TEMPORARY PAVEMENT











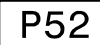

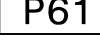

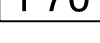

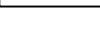
SIGNALS

-  EXISTING
-  PROPOSED
-  TEMPORARY

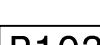









PAVEMENT MARKINGS

-  EXISTING LINES
-  TEMPORARY LINES



TEMPORARY PAVEMENT MARKING

- | | | | |
|---|-------------------------------------|--|-----------------------------------|
|  P1 | PAINT 4" WHITE EDGELINE |  P52 | PAINT 12" YELLOW DIAGONAL |
|  P2 | PAINT 4" WHITE SOLID LANE LINE |  P61 | PAINT 24" WHITE STOP BAR |
|  P4 | PAINT 4" 3'-9"/SP. WHITE MINI-SKIP |  P70 | PAINT LEFT TURN ARROW |
|  P5 | PAINT 4" 2'-6"/SP. WHITE MINI-SKIP |  P71 | PAINT RIGHT TURN ARROW |
|  P11 | PAINT 4" YELLOW SINGLE CENTER |  P73 | PAINT COMBO. LEFT/STRAIGHT ARROW |
|  P12 | PAINT 4" 10'-30"/SP. YELLOW SKIP |  P74 | PAINT COMBO. RIGHT/STRAIGHT ARROW |
|  P13 | PAINT 4" YELLOW DOUBLE CENTER |  P103 | PAINT 24" YIELD LINE TRIANGLE |
|  P14 | PAINT 4" 2'-6"/SP. YELLOW MINI-SKIP | | |
|  P40 | PAINT 8" WHITE GORELINE | | |
|  P51 | PAINT 12" WHITE DIAGONAL | | |



TRAFFIC CONTROL DEVICES

-  BARRICADE (TYPE III)
-  CONE
-  DRUM
-  SKINNY DRUM
-  TUBULAR MARKER
-  TEMPORARY CRASH CUSHION
-  FLASHING ARROW BOARD
-  FLAGGER
-  LAW ENFORCEMENT
-  TRUCK MOUNTED ATTENUATOR (TMA)
-  CHANGEABLE MESSAGE SIGN

TEMPORARY SIGNING

-  PORTABLE SIGN
-  STATIONARY SIGN
-  STATIONARY OR PORTABLE SIGN



PAVEMENT MARKERS

-  CRYSTAL/CRYSTAL
-  CRYSTAL/RED
-  YELLOW/YELLOW

PAVEMENT MARKING SYMBOLS

-  PAVEMENT MARKING SYMBOLS

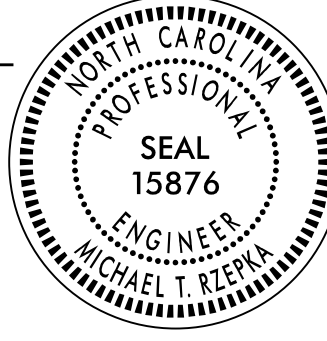
PLOT DRIVER: NCDOT_pdr_color_eng_50.plt
 USER: CHARNDEN
 DATE: 5/4/2022
 FILE: p:\p\p\h\users\charnd\us-east-01\Documents\3322\10002133\10279033\6.0_CAD_BIM\6.2_WIP\TrafficControl\TCR3830_TC_TMP-01A.dgn
 PENTABLE: NCDOT_tcp.tbl
 TIME: 10:44:33 AM

APPROVED: <i>Michael T. Rygga</i> DATE: 7/12/2022 		ROADWAY STANDARD DRAWINGS & LEGEND
DOCUMENT NOT CONSIDERED FINAL UNLESS ALL SIGNATURES COMPLETED		

MANAGEMENT STRATEGIES

GENERAL NOTES

PHASE 1 STEP 1:

- PROPOSED WEDGING AND WIDENING, DRAINAGE, AND CURB AND GUTTER WORK WILL BEGIN ALONG MAINLINE (-L-) USING DAILY LANE CLOSURES AND SHIFTED/NARROWED LANES AND/OR PORTABLE CONCRETE BARRIER FOR SEPARATION.
- LONG-TERM ROAD CLOSURE (30 DAYS) WITH OFFSITE DETOUR WILL OCCUR FOR -Y13- ACCESS TO -L- TO CONSTRUCT TIE. SHORT-TERM ROAD CLOSURE (WEEKEND) WITH OFFSITE DETOUR WILL OCCUR ON -L- AT -Y17- FOR CROSS-PIPE INSTALLATION.
- LANE REDUCTION AND CONCRETE BARRIER WILL BE USED FOR ROAD WORK UNDER US 421 BRIDGE.

PHASE 1 STEP 2:

- TEMPORARY SHORING AND PORTABLE CONCRETE BARRIER WILL BE INSTALLED ON -L- NEAR -Y16- TO INSTALL DRAINAGE PIPE AND GRADE CHANGE AREA. EB & WB TRAFFIC ON -L- WILL BE SHIFTED TO PREVIOUSLY CONSTRUCTED TEMPORARY PAVEMENT WIDENING TO FACILITATE CONSTRUCTION.

PHASE 2:

- TRAFFIC WILL BE SHIFTED TO TEMPORARY PATTERNS IN COMPLETED PHASE 1 AREAS TO CONSTRUCT AREAS NOT STARTED IN PHASE 1.
- TEMPORARY SHORING AND PORTABLE CONCRETE BARRIER WILL BE INSTALLED ALONG -L- AT AND EAST OF -Y16- TO INSTALL DRAINAGE PIPE AND GRADE CHANGE AREA. EB & WB TRAFFIC WILL BE SHIFTED ALONG -L- TO USE PREVIOUSLY CONSTRUCTED TEMPORARY PAVEMENT WIDENING AT AND EAST OF -Y16- TO FACILITATE CONSTRUCTION.

PHASE 3:

- TRAFFIC WILL BE SHIFTED TO ONE PATTERNS ALONG THE OUTSIDE OF COMPLETED WIDENING OF -L- FROM BEGIN PROJECT TO -Y16- TO CONSTRUCT -L- MEDIAN.
- EB & WB TRAFFIC ALONG -L- WILL BE SHIFTED TO USE PROPOSED EB PAVEMENT EAST OF -Y16- TO END PROJECT LIMIT. TEMPORARY SHORING AND PORTABLE CONCRETE BARRIER WILL BE INSTALLED ALONG EASTBOUND -L- EAST OF -Y16- TO COMPLETE PIPE INSTALLATION AND GRADE CHANGE AREA AND COMPLETE WIDENING ALONG WB SIDE OF -L-.

PHASE 4:

- USING LANE CLOSURES, FINAL LAYER OF SURFACE COURSE WILL BE INSTALLED AND PAVEMENT MARKINGS PLACED ALONG -L- AND ALL -Y- LINES WILL BE INSTALLED, ALONG WITH FINAL SIGNAL INSTALLATION AND ACTIVATION.

CHANGES MAY BE REQUIRED WHEN PHYSICAL DIMENSIONS IN THE DETAIL DRAWINGS, STANDARD DETAILS, AND ROADWAY DETAILS ARE NOT ATTAINABLE TO MEET FIELD CONDITIONS OR RESULT IN DUPLICATE OR UNDESIRED OVERLAPPING OF DEVICES. MODIFICATION MAY INCLUDE: MOVING, SUPPLEMENTING, COVERING, OR REMOVAL OF DEVICES AS DIRECTED BY THE ENGINEER.

THE FOLLOWING GENERAL NOTES APPLY AT ALL TIMES FOR THE DURATION OF THE CONSTRUCTION PROJECT EXCEPT WHEN OTHERWISE NOTED IN THE PLAN OR DIRECTED BY THE ENGINEER.

TIME RESTRICTIONS

A) DO NOT CLOSE OR NARROW TRAVEL LANES AS FOLLOWS:

<u>ROAD NAME</u>	<u>DAY AND TIME RESTRICTIONS</u>
-L- (NC 42)	MONDAY - FRIDAY
-Y1- (HORNERS BLVD)	6:00 AM TO 9:00 AM & 4:00 PM TO 7:00 PM

B) DO NOT CLOSE OR NARROW TRAVEL LANES DURING HOLIDAYS AND SPECIAL EVENTS AS FOLLOWS:

ROAD NAME

- L- (NC 42)
- Y1- (HORNERS BLVD)

HOLIDAY

1. FOR ANY UNEXPECTED OCCURRENCE THAT CREATES UNUSUALLY HIGH TRAFFIC VOLUMES, AS DIRECTED BY THE ENGINEER.
2. FOR NEW YEAR'S, BETWEEN THE HOURS OF 6:00 AM DECEMBER 31st TO 7:00 PM JANUARY 2ND. IF NEW YEAR'S DAY IS ON A FRIDAY, SATURDAY, SUNDAY, OR MONDAY THEN UNTIL 7:00 PM THE FOLLOWING TUESDAY.
3. FOR EASTER, BETWEEN THE HOURS OF 6:00 AM THURSDAY AND 7:00 PM MONDAY.
4. FOR MEMORIAL DAY, BETWEEN THE HOURS OF 6:00 AM FRIDAY TO 7:00 PM TUESDAY.
5. FOR INDEPENDENCE DAY, BETWEEN THE HOURS OF 6:00 AM THE DAY BEFORE INDEPENDENCE DAY AND 7:00 PM THE DAY AFTER INDEPENDENCE DAY.

IF INDEPENDENCE DAY IS ON A FRIDAY, SATURDAY, SUNDAY OR MONDAY THEN BETWEEN THE HOURS OF 6:00 AM THE THURSDAY BEFORE INDEPENDENCE DAY AND 7:00 PM THE TUESDAY AFTER INDEPENDENCE DAY.
6. FOR LABOR DAY, BETWEEN THE HOURS OF 6:00 AM FRIDAY AND 7:00 PM TUESDAY.
7. FOR THANKSGIVING DAY, BETWEEN THE HOURS OF 6:00 AM TUESDAY TO 7:00 PM MONDAY.
8. FOR CHRISTMAS, BETWEEN THE HOURS OF 6:00 AM THE FRIDAY BEFORE THE WEEK OF CHRISTMAS DAY AND 7:00 PM THE FOLLOWING TUESDAY AFTER THE WEEK OF CHRISTMAS.

C) DO NOT CONDUCT MULTI-VEHICLE HAULING AS FOLLOWS; INGRESS AND EGRESS FROM RAMP WILL BE ALLOWED:

<u>ROAD NAME</u>	<u>DAY AND TIME RESTRICTIONS</u>
-L- (NC 42)	MONDAY - FRIDAY
-Y1- (HORNERS BLVD)	6:00 AM TO 9:00 AM & 4:00 PM TO 7:00 PM

D) DO NOT CONDUCT ANY HAULING OPERATIONS AGAINST THE FLOW OF TRAFFIC OF AN OPEN TRAVELWAY UNLESS THE HAULING OPERATION IS PROTECTED BY BARRIER OR GUARDRAIL OR AS DIRECTED BY THE ENGINEER.

LANE AND SHOULDER CLOSURE REQUIREMENTS

- E) REMOVE LANE CLOSURE DEVICES FROM THE LANE WHEN WORK IS NOT BEING PERFORMED BEHIND THE LANE CLOSURE OR WHEN A LANE CLOSURE IS NO LONGER NEEDED OR AS DIRECTED BY THE ENGINEER.
- F) WHEN PERSONNEL AND/OR EQUIPMENT ARE WORKING WITHIN 15 FT OF AN OPEN TRAVEL LANE, CLOSE THE NEAREST OPEN SHOULDER USING ROADWAY STANDARD DRAWING NO. 1101.04 UNLESS THE WORK AREA IS PROTECTED BY BARRIER OR GUARDRAIL OR A LANE CLOSURE IS INSTALLED.
- G) WHEN PERSONNEL AND/OR EQUIPMENT ARE WORKING ON THE SHOULDER ADJACENT TO AN UNDIVIDED FACILITY AND WITHIN 5 FT OF AN OPEN TRAVEL LANE, CLOSE THE NEAREST OPEN TRAVEL LANE USING ROADWAY STANDARD DRAWING NO. 1101.02 UNLESS THE WORK AREA IS PROTECTED BY BARRIER OR GUARDRAIL.

WHEN PERSONNEL AND/OR EQUIPMENT ARE WORKING ON THE SHOULDER ADJACENT TO A DIVIDED FACILITY AND WITHIN 10 FT OF AN OPEN TRAVEL LANE, CLOSE THE NEAREST OPEN TRAVEL LANE USING ROADWAY STANDARD DRAWING NO. 1101.02 UNLESS THE WORK AREA IS PROTECTED BY BARRIER OR GUARDRAIL.
- H) WHEN PERSONNEL AND/OR EQUIPMENT ARE WORKING WITHIN A LANE OF TRAVEL OF AN UNDIVIDED OR DIVIDED FACILITY, CLOSE THE LANE ACCORDING TO THE TRAFFIC CONTROL PLANS, ROADWAY STANDARD DRAWINGS, OR AS DIRECTED BY THE ENGINEER. CONDUCT THE WORK SO THAT ALL PERSONNEL AND/OR EQUIPMENT REMAIN WITHIN THE CLOSED TRAVEL LANE.
- I) DO NOT WORK SIMULTANEOUSLY WITHIN 15 FT ON BOTH SIDES OF AN OPEN TRAVELWAY, RAMP, OR LOOP WITHIN THE SAME LOCATION UNLESS PROTECTED WITH GUARDRAIL OR BARRIER.
- J) DO NOT INSTALL MORE THAN ONE LANE CLOSURE IN ANY ONE DIRECTION ON NC 42.

PLOT DRIVER: NCDOT_pdf_color_eng_50.pht PENTABLE: NCDOT_tcp.tbl
USER: CHARNDEN DATE: 5/4/2022 TIME: 11:02:40 AM
FILE: pw:\pwhdr\useads01\HDR_US_East_01\Documents\3322\10002133\10279033\6_0_CAD.BIM\6_2.WIP\Traffic\TrafficControl\TCP\3830_TC_TMP-01BC.dgn

REVISIONS

APPROVED: <i>Michael T. Rzepka</i> DATE: 7/12/2022 <div style="text-align: center;">SEAL</div>			<p>TRANSPORTATION OPERATIONS PLAN (SHEET 1 OF 2)</p>
<p>DOCUMENT NOT CONSIDERED FINAL UNLESS ALL SIGNATURES COMPLETED</p>			

PROJ. REFERENCE NO. R-3830	SHEET NO. TMP-1C
-------------------------------	---------------------



GENERAL NOTES (CONT.)

PAVEMENT EDGE DROP OFF REQUIREMENTS

- K) BACKFILL AT A 6:1 SLOPE UP TO THE EDGE AND ELEVATION OF EXISTING PAVEMENT IN AREAS ADJACENT TO AN OPENED TRAVEL LANE THAT HAS AN EDGE OF PAVEMENT DROP-OFF AS FOLLOWS:
- BACKFILL DROP-OFFS THAT EXCEED 2 INCHES ON ROADWAYS WITH POSTED SPEED LIMITS OF 45 MPH OR GREATER.
- BACKFILL DROP-OFFS THAT EXCEED 3 INCHES ON ROADWAYS WITH POSTED SPEED LIMITS LESS THAN 45 MPH.
- BACKFILL WITH SUITABLE COMPACTED MATERIAL, AS APPROVED BY THE ENGINEER, AT NO EXPENSE TO THE DEPARTMENT.
- L) DO NOT EXCEED A DIFFERENCE OF 2 INCHES IN ELEVATION BETWEEN OPEN LANES OF TRAFFIC FOR NOMINAL LIFTS OF 1.5 INCHES. INSTALL ADVANCE WARNING "UNEVEN LANES" SIGNS (W8-11) 500' IN ADVANCE AND A MINIMUM OF EVERY HALF MILE THROUGHOUT THE UNEVEN AREA.

TRAFFIC PATTERN ALTERATIONS

- M) NOTIFY THE ENGINEER THIRTY (30) CALENDAR DAYS PRIOR TO ANY TRAFFIC PATTERN ALTERATION.

SIGNING

- N) INSTALL ADVANCE WORK ZONE WARNING SIGNS WHEN WORK IS WITHIN 40 FT FROM THE EDGE OF TRAVEL LANE AND NO MORE THAN THREE (3) DAYS PRIOR TO THE BEGINNING OF CONSTRUCTION.
- O) PROVIDE SIGNING AND DEVICES REQUIRED TO CLOSE THE ROAD ACCORDING TO THE ROADWAY STANDARD DRAWINGS TRAFFIC CONTROL PLANS.
- PROVIDE SIGNING REQUIRED FOR THE OFF-SITE DETOUR ROUTE AS SHOWN IN THE TRAFFIC CONTROL PLANS.
- P) COVER OR REMOVE ALL SIGNS AND DEVICES REQUIRED TO CLOSE THE ROAD WHEN ROAD CLOSURE IS NOT IN OPERATION.
- COVER OR REMOVE ALL SIGNS REQUIRED FOR THE OFF-SITE DETOUR WHEN THE DETOUR IS NOT IN OPERATION.
- Q) ENSURE ALL NECESSARY SIGNING IS IN PLACE PRIOR TO ALTERING ANY TRAFFIC PATTERN.
- R) INSTALL BLACK ON ORANGE "DIP" SIGNS (W8-2) AND/OR "BUMP" SIGNS (W8-1) 500' IN ADVANCE OF THE UNEVEN AREA, OR AS DIRECTED BY THE ENGINEER.

TRAFFIC BARRIER

- S) INSTALL TEMPORARY BARRIER ACCORDING TO THE TRANSPORTATION MANAGEMENT PLANS A MAXIMUM OF TWO (2) WEEKS PRIOR TO BEGINNING WORK IN ANY LOCATION. ONCE TEMPORARY BARRIER IS INSTALLED AT ANY LOCATION PROCEED IN A CONTINUOUS MANNER TO COMPLETE THE PROPOSED WORK IN THAT LOCATION UNLESS OTHERWISE STATED IN THE TRANSPORTATION MANAGEMENT PLANS OR AS DIRECTED BY THE ENGINEER.

DO NOT PLACE BARRIER DIRECTLY ON ANY SURFACE OTHER THAN ASPHALT OR CONCRETE.

ONCE TEMPORARY BARRIER IS INSTALLED AT ANY LOCATION AND NO WORK IS PERFORMED BEHIND THE TEMPORARY BARRIER FOR A PERIOD LONGER THAN TWO (2) MONTHS, REMOVE / RESET TEMPORARY BARRIER AT NO COST TO THE DEPARTMENT UNLESS OTHERWISE STATED IN THE TRANSPORTATION MANAGEMENT PLANS, TEMPORARY BARRIER IS PROTECTING A HAZARD, OR AS DIRECTED BY THE ENGINEER.

INSTALL TEMPORARY BARRIER WITH THE TRAFFIC FLOW BEGINNING WITH THE UPSTREAM SIDE OF TRAFFIC. REMOVE TEMPORARY BARRIER AGAINST THE TRAFFIC FLOW BEGINNING WITH THE DOWNSTREAM SIDE OF TRAFFIC.

INSTALL AND SPACE DRUMS NO GREATER THAN TWICE THE POSTED SPEED LIMIT (MPH) TO CLOSE OR KEEP THE SECTION OF THE ROADWAY CLOSED UNTIL THE TEMPORARY BARRIER CAN BE PLACED OR AFTER THE TEMPORARY BARRIER IS REMOVED.

- T) PROTECT THE APPROACH END OF MOVABLE/PORTABLE CONCRETE BARRIER AT ALL TIMES DURING THE INSTALLATION AND REMOVAL OF THE BARRIER BY EITHER A TRUCK MOUNTED ATTENUATOR (MAXIMUM 72 HOURS) OR A TEMPORARY CRASH CUSHION.

PROTECT THE APPROACH END OF MOVABLE/PORTABLE CONCRETE BARRIER FROM ONCOMING TRAFFIC AT ALL TIMES BY A TEMPORARY CRASH CUSHION UNLESS THE APPROACH END OF MOVABLE/PORTABLE CONCRETE BARRIER IS OFFSET FROM ONCOMING TRAFFIC AS FOLLOWS OR AS SHOWN IN THE PLANS: (SEE ALSO 1101.05)

POSTED SPEED LIMIT	MINIMUM OFFSET
40 OR LESS	15 FT
45 - 50	20 FT
55	25 FT
60 MPH or HIGHER	30 FT

TRAFFIC CONTROL DEVICES

- U) WHEN LANE CLOSURES ARE NOT IN EFFECT SPACE CHANNELIZING DEVICES IN WORK AREAS NO GREATER IN FEET THAN TWICE THE POSTED SPEED LIMIT (MPH) EXCEPT, 10 FT ON-CENTER IN RADII, AND 3 FT OFF THE EDGE OF AN OPEN TRAVELWAY. REFER TO STANDARD SPECIFICATIONS FOR ROADS AND STRUCTURES SECTIONS 1130 (DRUMS), 1135 (CONES) AND 1180 (SKINNY DRUMS) FOR ADDITIONAL REQUIREMENTS.
- V) PLACE TYPE III BARRICADES, WITH "ROAD CLOSED" SIGN R11-2 ATTACHED, OF SUFFICIENT LENGTH TO CLOSE ENTIRE ROADWAY.
- W) PLACE ADDITIONAL SETS OF THREE CHANNELIZING DEVICES PERPENDICULAR TO THE EDGE OF TRAVELWAY ON 500 FT CENTERS WHEN UNOPENED LANES ARE CLOSED TO TRAFFIC.

PAVEMENT MARKINGS AND MARKERS

- X) INSTALL TEMPORARY PAVEMENT MARKINGS AND TEMPORARY PAVEMENT MARKERS ON INTERIM LAYERS OF PAVEMENT AS FOLLOWS:

ROAD NAME	MARKING	MARKER
ALL ROADS	PAINT	TEMPORARY RAISED

- Y) PLACE ONE APPLICATION OF PAINT FOR TEMPORARY TRAFFIC PATTERNS. PLACE A SECOND APPLICATION OF PAINT SIX (6) MONTHS AFTER THE INITIAL APPLICATION AND EVERY SIX MONTHS AS DIRECTED BY THE ENGINEER.
- Z) TIE PROPOSED PAVEMENT MARKING LINES TO EXISTING PAVEMENT MARKING LINES.
- AA) REMOVE/REPLACE ANY CONFLICTING/DAMAGED PAVEMENT MARKINGS AND MARKERS BY THE END OF EACH DAY'S OPERATION.
- BB) TRACE THE PROPOSED MONOLITHIC ISLAND LOCATIONS WITH PROPER COLOR PAVEMENT MARKINGS PRIOR TO INSTALLATIONS. PLACE DRUMS TO DELINEATE ANY MONOLITHIC ISLANDS.

MISCELLANEOUS

- CC) LAW ENFORCEMENT MAY BE USED TO MAINTAIN TRAFFIC THROUGH THE WORK AREA AND/OR INTERSECTIONS AS DIRECTED BY THE ENGINEER.
- DD) IN THE EVENT A TIE-IN CANNOT BE MADE IN ONE DAY'S TIME, BRING THE TIE-IN AREA TO AN APPROPRIATE ROADWAY ELEVATION AS DETERMINED BY THE ENGINEER. PLACE BLACK ON ORANGE "LOOSE GRAVEL" SIGNS (W8-7) AND BLACK ON ORANGE "PAVEMENT ENDS" SIGNS (W8-3) [LENGTH] AND [LENGTH] RESPECTIVELY IN ADVANCE OF THE UNEVEN AREAS. USE DRUMS TO DELINEATE THE EDGE OF ROADWAY ALONG UNPAVED AREAS.
- EE) CONTRACTOR SHALL MAINTAIN SIDEWALK ACCESS AT ALL TIMES AS STATED IN THE PHASING. CONTRACTOR SHALL BE RESPONSIBLE TO PROVIDE TEMPORARY SIDEWALKS (CONCRETE, ASPHALT, OR OTHER SUITABLE MATERIAL AS APPROVED BY THE ENGINEER) AT ALL LOCATIONS WHERE THE OPEN PEDESTRIAN TRAVELWAY HAS BEEN REMOVED FOR CONSTRUCTION OPERATIONS (UTILITIES, DRAINAGE, ETC.).

LOCAL NOTE

- 1) ALL WATER MAIN INSTALLATION PROPOSED TO BE IN THE EXISTING ROADWAY SHALL BE PERFORMED BETWEEN THE HOURS OF 9 PM AND 6 AM. CONTRACTOR SHALL COORDINATE WITH CITY OF SANFORD AND NCDOT TO SCHEDULE WORK.

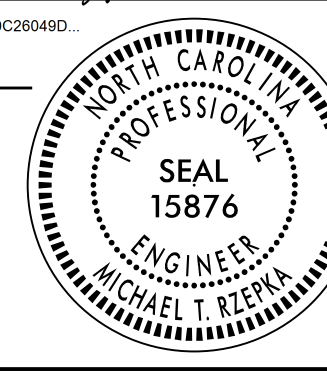
APPROVED: 
DATE: 7/12/2022
SEAL

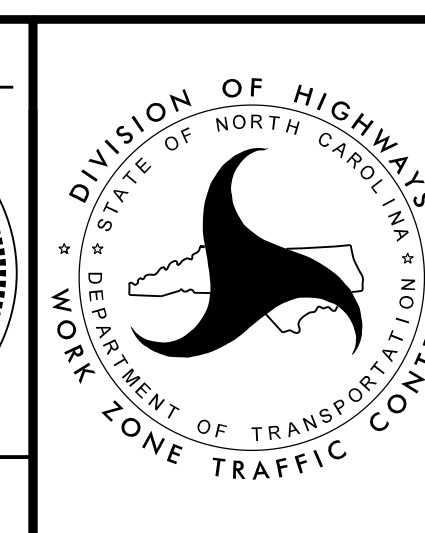
DOCUMENT NOT CONSIDERED FINAL UNLESS ALL SIGNATURES COMPLETED



TRANSPORTATION
OPERATIONS PLAN
(SHEET 2 OF 2)

PLOT DRIVER: NCDOT_pdf_mono_eng_50uplt
 USER: WRZEPKA
 DATE: 7/12/2022
 TIME: 1:03:11 PM
 FILE: p:\p\h\p\users\01\h\us_east_01\Documents\3322\10002133\10279033\6_0_CAD_BITMAP_6_2_WIP\Traffic\TrafficControl\CPAR3830_TC_TMP-01BC.dgn

REVISIONS

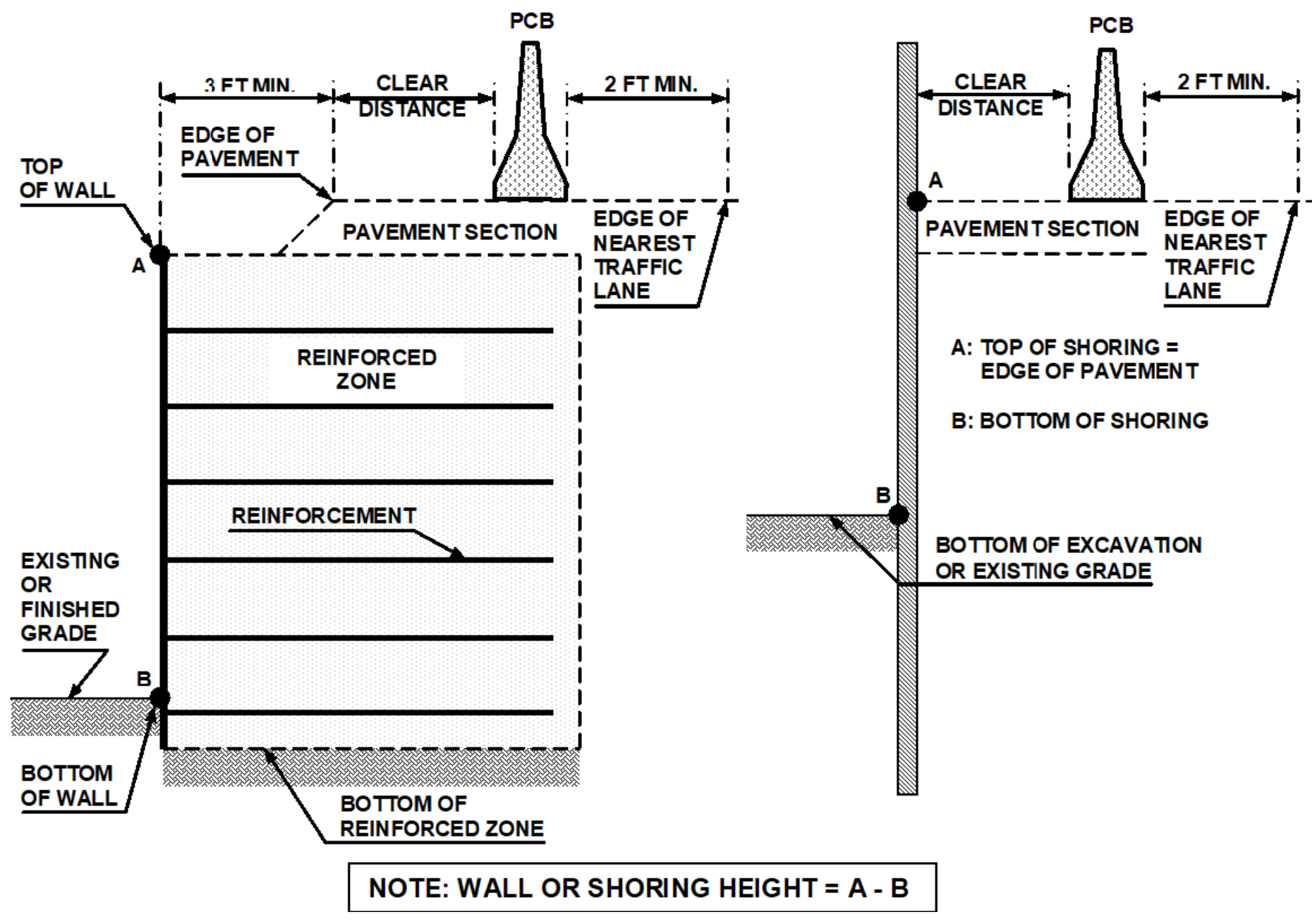

FIGURE A

NOTES

- REFER TO THE TRAFFIC CONTROL PLANS FOR TEMPORARY SHORING LOCATIONS AND NOTES.
- REFER TO THE "TEMPORARY SHORING" PROJECT SPECIAL PROVISION FOR INFORMATION ABOUT TEMPORARY SHORING AND PORTABLE CONCRETE BARRIER (PCB).
- PCB IS REQUIRED IF TEMPORARY SHORING IS LOCATED WITHIN THE CLEAR ZONE IN ACCORDANCE WITH THE AASHTO ROADSIDE DESIGN GUIDE. DO NOT PLACE BARRIER DIRECTLY ON ANY SURFACE OTHER THAN ASPHALT OR CONCRETE. (CONTACT NCDOT PAVEMENT MANAGEMENT UNIT FOR APPLICABLE PAVEMENT DESIGN).
- BASED ON THE CLEAR DISTANCE, OFFSET, DESIGN SPEED AND PAVEMENT TYPE, CHOOSE AN UNANCHORED OR ANCHORED PCB FROM THE TABLE SHOWN IN FIGURE B. CLEAR DISTANCE IS DEFINED AS SHOWN IN FIGURE A AND OFFSET IS DEFINED AS SHOWN IN FIGURE B.
- AT THE CONTRACTOR'S OPTION OR IF THE MINIMUM REQUIRED CLEAR DISTANCE IS NOT AVAILABLE, SET PCB NEXT TO AND UP AGAINST THE TRAFFIC SIDE OF THE TEMPORARY SHORING EXCEPT FOR BARRIER ABOVE TEMPORARY WALLS. PCB WITH THE MINIMUM REQUIRED CLEAR DISTANCE IS REQUIRED ABOVE TEMPORARY WALLS.
- USE NCDOT PORTABLE CONCRETE BARRIER (PCB) IN ACCORDANCE WITH ROADWAY STANDARD DRAWING NO. 1170.01 AND SECTION 1170 OF THE STANDARD SPECIFICATIONS.
- PCB REQUIREMENTS FOR TEMPORARY WALLS APPLY TO TEMPORARY MECHANICALLY STABILIZED EARTH (MSE) WALLS AND TEMPORARY SOIL NAIL WALLS.
- SET PCB WITH A MINIMUM HORIZONTAL DISTANCE OF 2 FT BETWEEN THE FRONT FACE OF THE BARRIER AND THE EDGE OF THE NEAREST TRAFFIC LANE AS SHOWN IN FIGURE A UNLESS OTHERWISE SHOWN IN THE PLANS AND OR AS APPROVED BY THE ENGINEER.
- FOR PCB ABOVE AND BEHIND TEMPORARY WALLS, PROVIDE A MINIMUM DISTANCE OF 3 FT BETWEEN THE EDGE OF PAVEMENT AND THE WALL FACE AS SHOWN IN FIGURE A. IF THESE MINIMUM REQUIRED DISTANCES ARE NOT AVAILABLE, CONTACT THE ENGINEER.
- TABLE SHOWN IN FIGURE B IS BASED ON NCDOT RESEARCH PROJECT NO. 2005-010 WITH VEHICLE TYPE USED FOR NCHRP 350 CRASH TESTS. BARRIER DEFLECTIONS AND RESULTING MINIMUM REQUIRED CLEAR DISTANCES MIGHT VARY SIGNIFICANTLY FOR LARGER HEAVIER VEHICLES, RUNS OF BARRIER LESS THAN 200 FT IN LENGTH AND WET OR DRY PAVEMENT.

MINIMUM REQUIRED CLEAR DISTANCE, inches

Barrier Type	Pavement Type	Offset * ft	Design Speed, mph					
			<30	31-40	41-50	51-60	61-70	71-80
Unanchored PCB	Asphalt	<8	24	26	29	32	36	40
		8-14	26	28	31	35	38	42
		14-20	27	29	34	36	39	43
		20-26	28	31	35	38	40	44
		26-32	29	32	36	39	42	45
		32-38	30	34	38	41	43	46
		38-44	31	34	41	43	45	48
		44-50	31	35	41	43	46	49
	Concrete	50-56	32	36	42	44	47	50
		>56	32	36	42	45	47	51
		<8	17	18	21	22	25	26
		8-14	19	20	23	25	26	29
		14-20	22	22	24	26	28	31
		20-26	23	24	26	27	30	34
		26-32	24	25	27	28	32	35
		32-38	24	26	27	30	33	36
Anchored PCB	Asphalt	All Offsets	24 for All Design Speeds					
			12 for All Design Speeds					

* See Figure Below

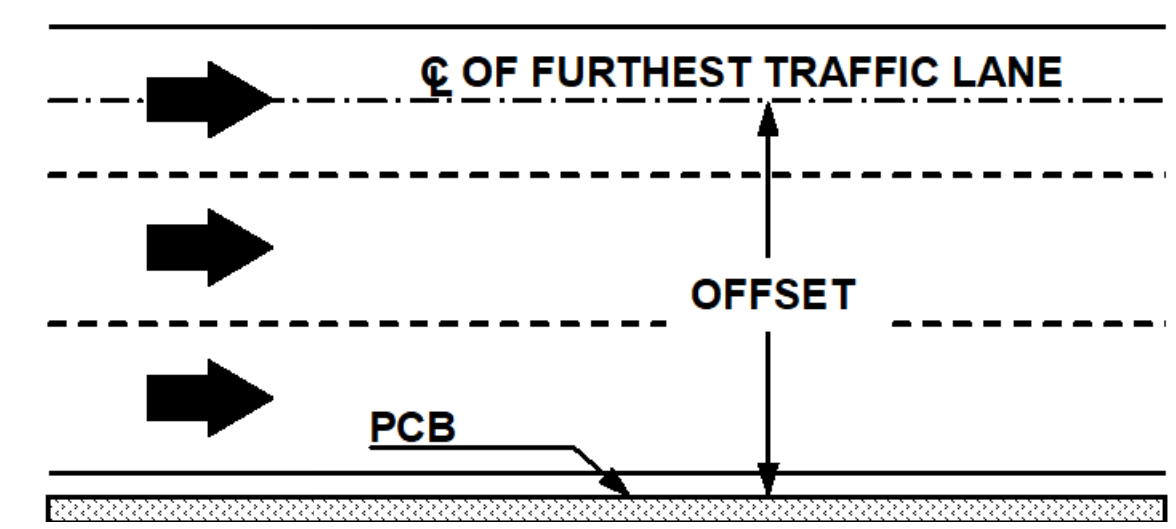
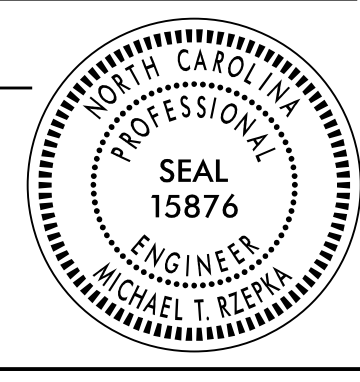



FIGURE B

PLOT DRIVER: NCDOT_pdf_color_eng_50.pit
 USER: CHARNDEN
 DATE: 5/4/2022
 FILE: p:\pwhdr\users\01\hdr\US_East\01\Documents\3322\10002133\10279033\6_0_CAD.BIM\6.2.WIP\Traffic\TrafficControl\TCP\R3830_TC_TMP-02.dgn
 REVISIONS

APPROVED: <i>Michael T. Repka</i> DATE: 7/12/2022 SEAL 		PORTABLE CONCRETE BARRIER AT TEMPORARY SHORING LOCATIONS
DOCUMENT NOT CONSIDERED FINAL UNLESS ALL SIGNATURES COMPLETED		

TEMPORARY SHORING DATA

PROJ. REFERENCE NO.	SHEET NO.
R-3830	TMP-2A
 HDR Engineering, Inc. of the Carolinas 555 Fayetteville St, Suite 900 Raleigh, N.C. 27601 N.C.B.E.L.S. License Number: F-0116	

TEMPORARY SHORING LOCATION NO. 1 (SEE TMP-4.01 & 4.02)

FOR TEMPORARY SHORING AND POSITIVE PROTECTION FOR TEMPORARY SHORING, SEE PLANS AND TEMPORARY SHORING PROVISION.

DESIGN TEMPORARY SHORING FROM STATION 23+00 +/- -L-, 37 FT. RT. TO STATION 27+70 +/- -L-, 37 FT. RT. FOR THE FOLLOWING ASSUMED SOIL PARAMETERS AND GROUNDWATER ELEVATION:

- UNIT WEIGHT OF SOIL ABOVE WATER TABLE, $\gamma = 120$ PCF
- UNIT WEIGHT OF SOIL BELOW WATER TABLE, $\gamma' = 60$ PCF
- FRICTION ANGLE, $\phi = 30$
- COHESION, $c = 0$ PSF
- GROUNDWATER ELEVATION = 433 FT.

BEFORE BEGINNING TEMPORARY SHORING DESIGN OR CONSTRUCTION, SURVEY EXISTING GROUND ELEVATIONS IN THE VICINITY OF SHORING LOCATIONS TO DETERMINE ACTUAL SHORING HEIGHTS.

LIMITED SUBSURFACE INFORMATION IS AVAILABLE IN THE VICINITY OF TEMPORARY SHORING FROM STATION 23+00 +/- -L-, 37 FT. RT. TO STATION 27+70 +/- -L-, 37 FT. RT. THE INFORMATION PROVIDED FOR TEMPORARY SHORING DESIGN WAS ASSUMED AND MAY NOT BE APPLICABLE TO THE ACTUAL SITE CONDITIONS ENCOUNTERED DURING CONSTRUCTION.

AT THE CONTRACTOR'S OPTION, USE STANDARD TEMPORARY SHORING FOR TEMPORARY SHORING FROM STATION 23+00 +/- -L-, 37 FT. RT. TO STATION 27+70 +/- -L-, 37 FT. RT. SEE GEOTECHNICAL STANDARD DETAIL NO. 1801.01 FOR STANDARD TEMPORARY SHORING.

TEMPORARY SHORING LOCATION NO. 2 (SEE TMP-5.01 & 5.02)

FOR TEMPORARY SHORING AND POSITIVE PROTECTION FOR TEMPORARY SHORING, SEE PLANS AND TEMPORARY SHORING PROVISION.

DESIGN TEMPORARY SHORING FROM STATION 170+00 +/- -L-, 7.5 FT. LT., TO STATION 174+00 +/- -L-, 7.0 FT. LT., FOR THE FOLLOWING ASSUMED SOIL PARAMETERS AND GROUNDWATER ELEVATION:

- UNIT WEIGHT OF SOIL ABOVE WATER TABLE, $\gamma = 120$ PCF
- UNIT WEIGHT OF SOIL BELOW WATER TABLE, $\gamma' = 60$ PCF
- FRICTION ANGLE, $\phi = 30$
- COHESION, $c = 0$ PSF
- GROUNDWATER ELEVATION = 404 FT.

BEFORE BEGINNING TEMPORARY SHORING DESIGN OR CONSTRUCTION, SURVEY EXISTING GROUND ELEVATIONS IN THE VICINITY OF SHORING LOCATIONS TO DETERMINE ACTUAL SHORING HEIGHTS.

LIMITED SUBSURFACE INFORMATION IS AVAILABLE IN THE VICINITY OF TEMPORARY SHORING FROM STATION 170+00 +/- -L-, 7.5 FT. LT., TO STATION 174+00 +/- -L-, 7.0 FT. LT. THE INFORMATION PROVIDED FOR TEMPORARY SHORING DESIGN WAS ASSUMED AND MAY NOT BE APPLICABLE TO THE ACTUAL SITE CONDITIONS ENCOUNTERED DURING CONSTRUCTION.

AT THE CONTRACTOR'S OPTION, USE A STANDARD TEMPORARY WALL FOR TEMPORARY SHORING FROM STATION 170+00 +/- -L-, 7.5 FT. LT., TO STATION 174+00 +/- -L-, 7.0 FT. LT. SEE GEOTECHNICAL STANDARD DETAIL NO. 1801.02 FOR STANDARD TEMPORARY WALLS.

TEMPORARY SHORING LOCATION NO. 3 (SEE TMP-5.01)

FOR TEMPORARY SHORING AND POSITIVE PROTECTION FOR TEMPORARY SHORING, SEE PLANS AND TEMPORARY SHORING PROVISION.

DESIGN TEMPORARY SHORING FROM STATION 170+50 +/- -L-, 7.7 FT. LT. TO STATION 171+65 +/- -L-, 6.6 FT. LT. FOR THE FOLLOWING ASSUMED SOIL PARAMETERS AND GROUNDWATER ELEVATION:

- UNIT WEIGHT OF SOIL ABOVE WATER TABLE, $\gamma = 120$ PCF
- UNIT WEIGHT OF SOIL BELOW WATER TABLE, $\gamma' = 60$ PCF
- FRICTION ANGLE, $\phi = 30$
- COHESION, $c = 0$ PSF
- GROUNDWATER ELEVATION = 404 FT.

BEFORE BEGINNING TEMPORARY SHORING DESIGN OR CONSTRUCTION, SURVEY EXISTING GROUND ELEVATIONS IN THE VICINITY OF SHORING LOCATIONS TO DETERMINE ACTUAL SHORING HEIGHTS.

LIMITED SUBSURFACE INFORMATION IS AVAILABLE IN THE VICINITY OF TEMPORARY SHORING FROM STATION 170+50 +/- -L-, 7.7 FT. LT. TO STATION 171+65 +/- -L-, 6.6 FT. LT. THE INFORMATION PROVIDED FOR TEMPORARY SHORING DESIGN WAS ASSUMED AND MAY NOT BE APPLICABLE TO THE ACTUAL SITE CONDITIONS ENCOUNTERED DURING CONSTRUCTION.

AT THE CONTRACTOR'S OPTION, USE STANDARD TEMPORARY SHORING FOR TEMPORARY SHORING FROM STATION 170+50 +/- -L-, 7.7 FT. LT. TO STATION 171+65 +/- -L-, 6.6 FT. LT. SEE GEOTECHNICAL STANDARD DETAIL NO. 1801.01 FOR STANDARD TEMPORARY SHORING.

TEMPORARY SHORING LOCATION NO. 4 (SEE TMP-6.12)

FOR TEMPORARY SHORING AND POSITIVE PROTECTION FOR TEMPORARY SHORING, SEE PLANS AND TEMPORARY SHORING PROVISION.

DESIGN TEMPORARY SHORING FROM STATION 186+00 +/- -L-, 5.4 FT. LT. TO STATION 194+00 +/- -L-, 3.4 FT. LT. FOR THE FOLLOWING ASSUMED SOIL PARAMETERS AND GROUNDWATER ELEVATION:

- UNIT WEIGHT OF SOIL ABOVE WATER TABLE, $\gamma = 120$ PCF
- UNIT WEIGHT OF SOIL BELOW WATER TABLE, $\gamma' = 60$ PCF
- FRICTION ANGLE, $\phi = 30$
- COHESION, $c = 0$ PSF
- GROUNDWATER ELEVATION = 402 FT.

BEFORE BEGINNING TEMPORARY SHORING DESIGN OR CONSTRUCTION, SURVEY EXISTING GROUND ELEVATIONS IN THE VICINITY OF SHORING LOCATIONS TO DETERMINE ACTUAL SHORING HEIGHTS.

LIMITED SUBSURFACE INFORMATION IS AVAILABLE IN THE VICINITY OF TEMPORARY SHORING FROM STATION 186+00 +/- -L-, 5.4 FT. LT. TO STATION 194+00 +/- -L-, 3.4 FT. LT. THE INFORMATION PROVIDED FOR TEMPORARY SHORING DESIGN WAS ASSUMED AND MAY NOT BE APPLICABLE TO THE ACTUAL SITE CONDITIONS ENCOUNTERED DURING CONSTRUCTION.

AT THE CONTRACTOR'S OPTION, USE A STANDARD TEMPORARY WALL FOR TEMPORARY SHORING FROM STATION 186+00 +/- -L-, 5.4 FT. LT. TO STATION 194+00 +/- -L-, 3.4 FT. LT. SEE GEOTECHNICAL STANDARD DETAIL NO. 1801.02 FOR STANDARD TEMPORARY WALLS.

TEMPORARY SHORING LOCATION NO. 5 (SEE TMP-6.12)

FOR TEMPORARY SHORING AND POSITIVE PROTECTION FOR TEMPORARY SHORING, SEE PLANS AND TEMPORARY SHORING PROVISION.

DESIGN TEMPORARY SHORING FROM STATION 189+50 +/- -L-, 5.3 FT. LT., TO STATION 190+70 +/- -L-, 5.1 FT. LT., FOR THE FOLLOWING ASSUMED SOIL PARAMETERS AND GROUNDWATER ELEVATION:

- UNIT WEIGHT OF SOIL ABOVE WATER TABLE, $\gamma = 120$ PCF
- UNIT WEIGHT OF SOIL BELOW WATER TABLE, $\gamma' = 60$ PCF
- FRICTION ANGLE, $\phi = 30$
- COHESION, $c = 0$ PSF
- GROUNDWATER ELEVATION = 402 FT.

BEFORE BEGINNING TEMPORARY SHORING DESIGN OR CONSTRUCTION, SURVEY EXISTING GROUND ELEVATIONS IN THE VICINITY OF SHORING LOCATIONS TO DETERMINE ACTUAL SHORING HEIGHTS.

LIMITED SUBSURFACE INFORMATION IS AVAILABLE IN THE VICINITY OF TEMPORARY SHORING FROM STATION 189+50 +/- -L-, 5.3 FT. LT., TO STATION 190+70 +/- -L-, 5.1 FT. LT. THE INFORMATION PROVIDED FOR TEMPORARY SHORING DESIGN WAS ASSUMED AND MAY NOT BE APPLICABLE TO THE ACTUAL SITE CONDITIONS ENCOUNTERED DURING CONSTRUCTION.

AT THE CONTRACTOR'S OPTION, USE A STANDARD TEMPORARY SHORING FOR TEMPORARY SHORING FROM STATION 189+50 +/- -L-, 5.3 FT. LT., TO STATION 190+70 +/- -L-, 5.1 FT. LT. SEE GEOTECHNICAL STANDARD DETAIL NO. 1801.01 FOR STANDARD TEMPORARY SHORING.

TEMPORARY SHORING LOCATION NO. 6 (SEE TMP-6.13)

FOR TEMPORARY SHORING AND POSITIVE PROTECTION FOR TEMPORARY SHORING, SEE PLANS AND TEMPORARY SHORING PROVISION.

DESIGN TEMPORARY SHORING FROM STATION 203+00 +/- -L-, 0.4 FT. LT. TO STATION 210+00 +/- -L-, CENTERLINE, FOR THE FOLLOWING ASSUMED SOIL PARAMETERS AND GROUNDWATER ELEVATION:

- UNIT WEIGHT OF SOIL ABOVE WATER TABLE, $\gamma = 120$ PCF
- UNIT WEIGHT OF SOIL BELOW WATER TABLE, $\gamma' = 60$ PCF
- FRICTION ANGLE, $\phi = 30$
- COHESION, $c = 0$ PSF
- GROUNDWATER ELEVATION = 407 FT.

BEFORE BEGINNING TEMPORARY SHORING DESIGN OR CONSTRUCTION, SURVEY EXISTING GROUND ELEVATIONS IN THE VICINITY OF SHORING LOCATIONS TO DETERMINE ACTUAL SHORING HEIGHTS.

LIMITED SUBSURFACE INFORMATION IS AVAILABLE IN THE VICINITY OF TEMPORARY SHORING FROM STATION 203+00 +/- -L-, 0.4 FT. LT. TO STATION 210+00 +/- -L-, CENTERLINE. THE INFORMATION PROVIDED FOR TEMPORARY SHORING DESIGN WAS ASSUMED AND MAY NOT BE APPLICABLE TO THE ACTUAL SITE CONDITIONS ENCOUNTERED DURING CONSTRUCTION.

AT THE CONTRACTOR'S OPTION, USE STANDARD TEMPORARY WALL FOR TEMPORARY SHORING FROM STATION 203+00 +/- -L-, 0.4 FT. LT. TO STATION 210+00 +/- -L-, CENTERLINE. SEE GEOTECHNICAL STANDARD DETAIL NO. 1801.02 FOR STANDARD TEMPORARY WALLS.

TEMPORARY SHORING LOCATION NO. 7 (SEE TMP-6.13)

FOR TEMPORARY SHORING AND POSITIVE PROTECTION FOR TEMPORARY SHORING, SEE PLANS AND TEMPORARY SHORING PROVISION.

DESIGN TEMPORARY SHORING FROM STATION 205+00 +/- -L-, 1.3 FT. LT. TO STATION 206+00 +/- -L-, 0.8 FT. LT. FOR THE FOLLOWING ASSUMED SOIL PARAMETERS AND GROUNDWATER ELEVATION:

- UNIT WEIGHT OF SOIL ABOVE WATER TABLE, $\gamma = 120$ PCF
- UNIT WEIGHT OF SOIL BELOW WATER TABLE, $\gamma' = 60$ PCF
- FRICTION ANGLE, $\phi = 30$
- COHESION, $c = 0$ PSF
- GROUNDWATER ELEVATION = 407 FT.

BEFORE BEGINNING TEMPORARY SHORING DESIGN OR CONSTRUCTION, SURVEY EXISTING GROUND ELEVATIONS IN THE VICINITY OF SHORING LOCATIONS TO DETERMINE ACTUAL SHORING HEIGHTS.

LIMITED SUBSURFACE INFORMATION IS AVAILABLE IN THE VICINITY OF TEMPORARY SHORING FROM STATION 205+00 +/- -L-, 1.3 FT. LT. TO STATION 206+00 +/- -L-, 0.8 FT. LT. THE INFORMATION PROVIDED FOR TEMPORARY SHORING DESIGN WAS ASSUMED AND MAY NOT BE APPLICABLE TO THE ACTUAL SITE CONDITIONS ENCOUNTERED DURING CONSTRUCTION.

AT THE CONTRACTOR'S OPTION, USE A STANDARD TEMPORARY SHORING FOR TEMPORARY SHORING FROM STATION 205+00 +/- -L-, 1.3 FT. LT. TO STATION 206+00 +/- -L-, 0.8 FT. LT. SEE GEOTECHNICAL STANDARD DETAIL NO. 1801.01 FOR STANDARD TEMPORARY SHORING.

TEMPORARY SHORING LOCATION NO. 8 (SEE TMP-6.13)

FOR TEMPORARY SHORING AND POSITIVE PROTECTION FOR TEMPORARY SHORING, SEE PLANS AND TEMPORARY SHORING PROVISION.

DESIGN TEMPORARY SHORING FROM STATION 189+50 +/- -L-, 5.3 FT. LT., TO STATION 190+70 +/- -L-, 5.1 FT. LT., FOR THE FOLLOWING ASSUMED SOIL PARAMETERS AND GROUNDWATER ELEVATION:

- UNIT WEIGHT OF SOIL ABOVE WATER TABLE, $\gamma = 120$ PCF
- UNIT WEIGHT OF SOIL BELOW WATER TABLE, $\gamma' = 60$ PCF
- FRICTION ANGLE, $\phi = 30$
- COHESION, $c = 0$ PSF
- GROUNDWATER ELEVATION = 402 FT.

BEFORE BEGINNING TEMPORARY SHORING DESIGN OR CONSTRUCTION, SURVEY EXISTING GROUND ELEVATIONS IN THE VICINITY OF SHORING LOCATIONS TO DETERMINE ACTUAL SHORING HEIGHTS.

LIMITED SUBSURFACE INFORMATION IS AVAILABLE IN THE VICINITY OF TEMPORARY SHORING FROM STATION 189+50 +/- -L-, 5.3 FT. LT., TO STATION 190+70 +/- -L-, 5.1 FT. LT. THE INFORMATION PROVIDED FOR TEMPORARY SHORING DESIGN WAS ASSUMED AND MAY NOT BE APPLICABLE TO THE ACTUAL SITE CONDITIONS ENCOUNTERED DURING CONSTRUCTION.

AT THE CONTRACTOR'S OPTION, USE A STANDARD TEMPORARY SHORING FOR TEMPORARY SHORING FROM STATION 189+50 +/- -L-, 5.3 FT. LT., TO STATION 190+70 +/- -L-, 5.1 FT. LT. SEE GEOTECHNICAL STANDARD DETAIL NO. 1801.01 FOR STANDARD TEMPORARY SHORING.

TEMPORARY SHORING LOCATION NO. 9 (SEE TMP-6.13)

FOR TEMPORARY SHORING AND POSITIVE PROTECTION FOR TEMPORARY SHORING, SEE PLANS AND TEMPORARY SHORING PROVISION.

DESIGN TEMPORARY SHORING FROM STATION 203+00 +/- -L-, 0.4 FT. LT. TO STATION 210+00 +/- -L-, CENTERLINE, FOR THE FOLLOWING ASSUMED SOIL PARAMETERS AND GROUNDWATER ELEVATION:

- UNIT WEIGHT OF SOIL ABOVE WATER TABLE, $\gamma = 120$ PCF
- UNIT WEIGHT OF SOIL BELOW WATER TABLE, $\gamma' = 60$ PCF
- FRICTION ANGLE, $\phi = 30$
- COHESION, $c = 0$ PSF
- GROUNDWATER ELEVATION = 407 FT.



BEFORE BEGINNING TEMPORARY SHORING DESIGN OR CONSTRUCTION, SURVEY EXISTING GROUND ELEVATIONS IN THE VICINITY OF SHORING LOCATIONS TO DETERMINE ACTUAL SHORING HEIGHTS.

LIMITED SUBSURFACE INFORMATION IS AVAILABLE IN THE VICINITY OF TEMPORARY SHORING FROM STATION 203+00 +/- -L-, 0.4 FT. LT. TO STATION 210+00 +/- -L-, CENTERLINE. THE INFORMATION PROVIDED FOR TEMPORARY SHORING DESIGN WAS ASSUMED AND MAY NOT BE APPLICABLE TO THE ACTUAL SITE CONDITIONS ENCOUNTERED DURING CONSTRUCTION.

AT THE CONTRACTOR'S OPTION, USE STANDARD TEMPORARY WALL FOR TEMPORARY SHORING FROM STATION 203+00 +/- -L-, 0.4 FT. LT. TO STATION 210+00 +/- -L-, CENTERLINE. SEE GEOTECHNICAL STANDARD DETAIL NO. 1801.02 FOR STANDARD TEMPORARY WALLS.

THE TEMPORARY SHORING NOTES SHOWN ON THIS SHEET WERE PROVIDED THROUGH A SEALED DOCUMENT FROM THE GEOTECHNICAL ENGINEERING UNIT. THE DOCUMENT WAS SUBMITTED TO THE WZTCU ON 9-1-2021 AND SEALED BY A PROFESSIONAL ENGINEER, DAVID L. TEAGUE, PE, LICENSE #027869.

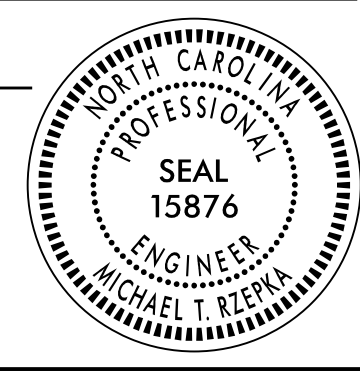
PLOT DRIVER: NCD01.pdf_color_eng_50.ppt
 USER: CHARNDEN
 FILE: p:\p\hdf\users\01\hdf\US_East_01\Documents\3322\10002133\10279033\6_0_CAD_BIM\6_2_WIP\Traffic\TrafficControl\CP\R3830_TC_TMP-02A.dgn
 REVISIONS
 PENTABLE: NCD01_tcp.tbl
 TIME: 10:44:51 AM
 DATE: 5/4/2022

APPROVED: <i>Michael T. Rzepka</i> DATE: 7/12/2022 SEAL 		TEMPORARY SHORING DATA
DOCUMENT NOT CONSIDERED FINAL UNLESS ALL SIGNATURES COMPLETED		

MESSAGE NO. 1	MESSAGE NO. 2
COX MILL CLSD AT BROADWAY	DETOUR USE US 421S
CHANGEABLE MESSAGE SIGN	
INSTALL CMS 1/2 MILE IN ADVANCE OF CLOSURE	

MESSAGE NO. 1	MESSAGE NO. 2
COX MILL CLSD AT BROADWAY	DETOUR USE US 421S
CHANGEABLE MESSAGE SIGN	
INSTALL CMS 1/2 MILE IN ADVANCE OF CLOSURE	

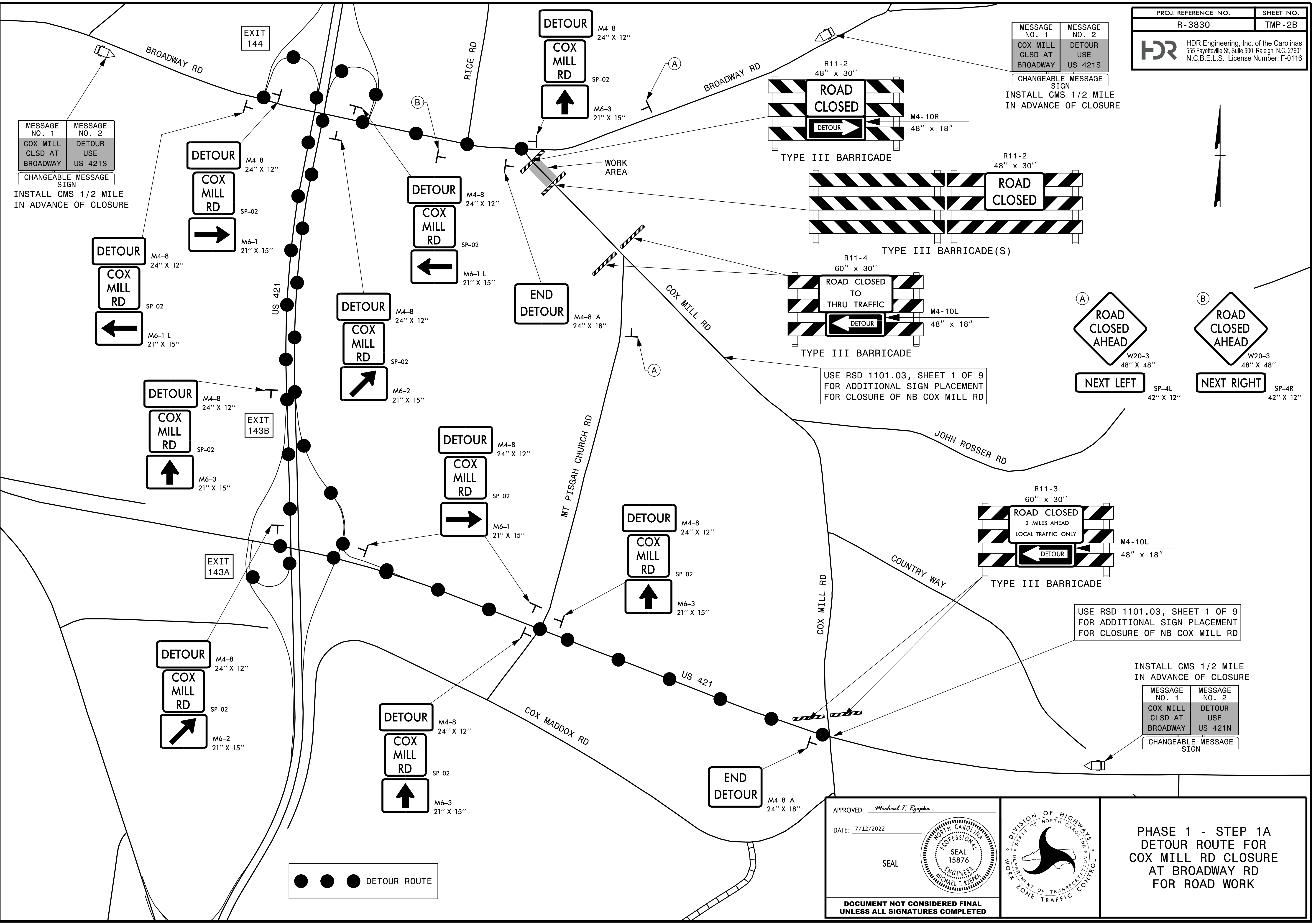

REVISIONS

PLOT DRIVER: NCDOT_pdf_color_eng_50.pit
 USER: CHARNDEN
 DATE: 5/4/2022
 FILE: p:\p\p\h\p\uses\01\h\p\US_East_01\Documents\3322\10002133\10279033\6_0_CAD.BIM\6.2.WIP\Traffic\TrafficControl\TCP\R3830_TC_TMP-02B.dgn

● ● ● DETOUR ROUTE

APPROVED: *Michael T. Rzepka*

DATE: 7/12/2022

SEAL

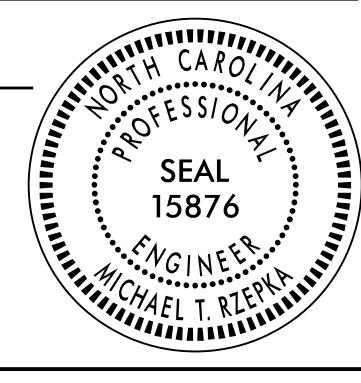

DOCUMENT NOT CONSIDERED FINAL UNLESS ALL SIGNATURES COMPLETED

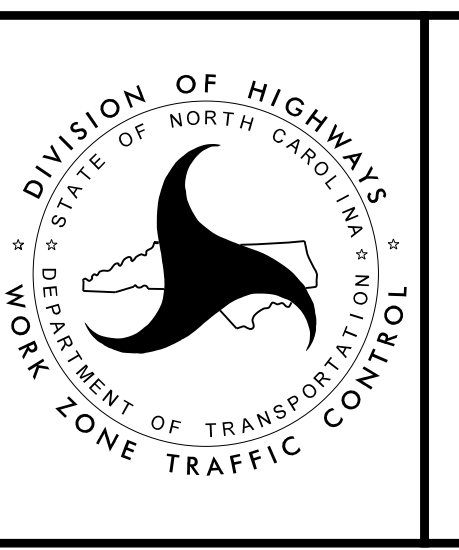

PHASE 1 - STEP 1A
 DETOUR ROUTE FOR
 COX MILL RD CLOSURE
 AT BROADWAY RD
 FOR ROAD WORK

(A) ROAD CLOSED AHEAD W20-3 48" X 48"

(B) ROAD CLOSED AHEAD W20-3 48" X 48"

NEXT LEFT SP-4L 42" X 12"

NEXT RIGHT SP-4R 42" X 12"

USE RSD 1101.03, SHEET 1 OF 9 FOR ADDITIONAL SIGN PLACEMENT FOR CLOSURE OF NB COX MILL RD

USE RSD 1101.03, SHEET 1 OF 9 FOR ADDITIONAL SIGN PLACEMENT FOR CLOSURE OF NB COX MILL RD

INSTALL CMS 1/2 MILE IN ADVANCE OF CLOSURE

MESSAGE NO. 1	MESSAGE NO. 2
COX MILL CLSD AT BROADWAY	DETOUR USE US 421N
CHANGEABLE MESSAGE SIGN	
INSTALL CMS 1/2 MILE IN ADVANCE OF CLOSURE	

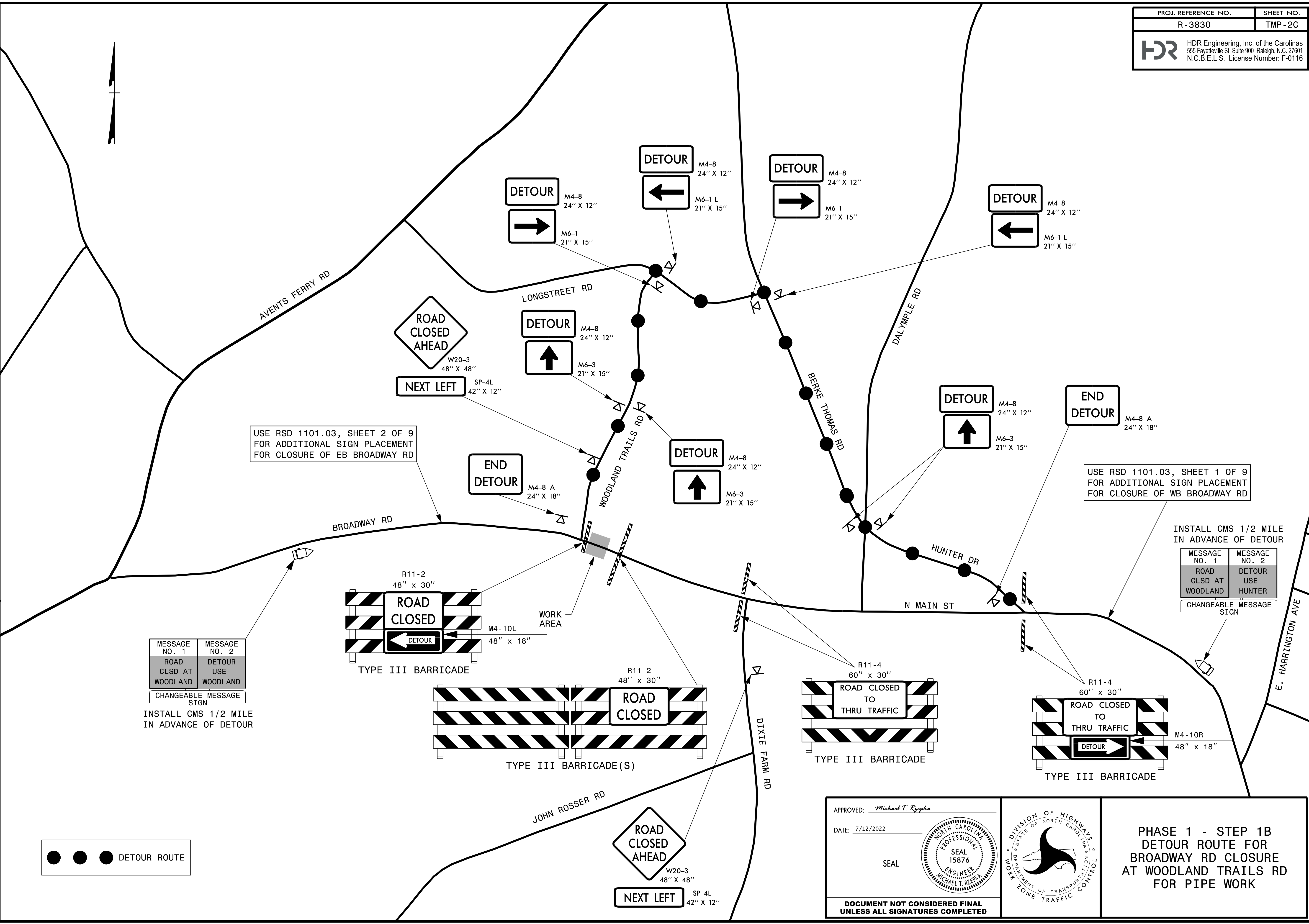

● ● ● DETOUR ROUTE

MESSAGE NO. 1	MESSAGE NO. 2
ROAD CLSD AT WOODLAND	DETOUR USE WOODLAND

CHANGEABLE MESSAGE SIGN

INSTALL CMS 1/2 MILE IN ADVANCE OF DETOUR

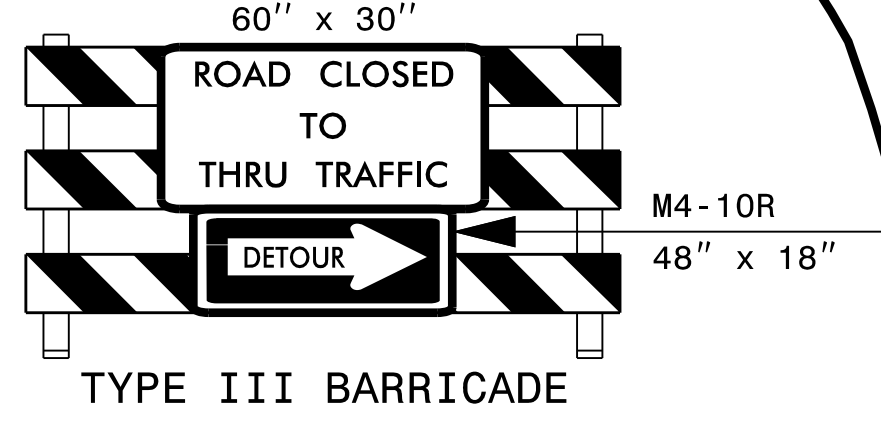
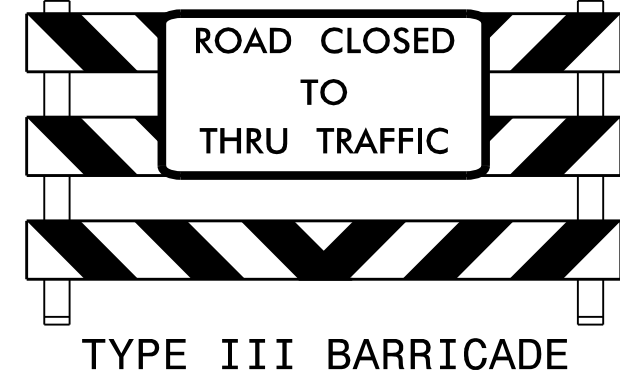
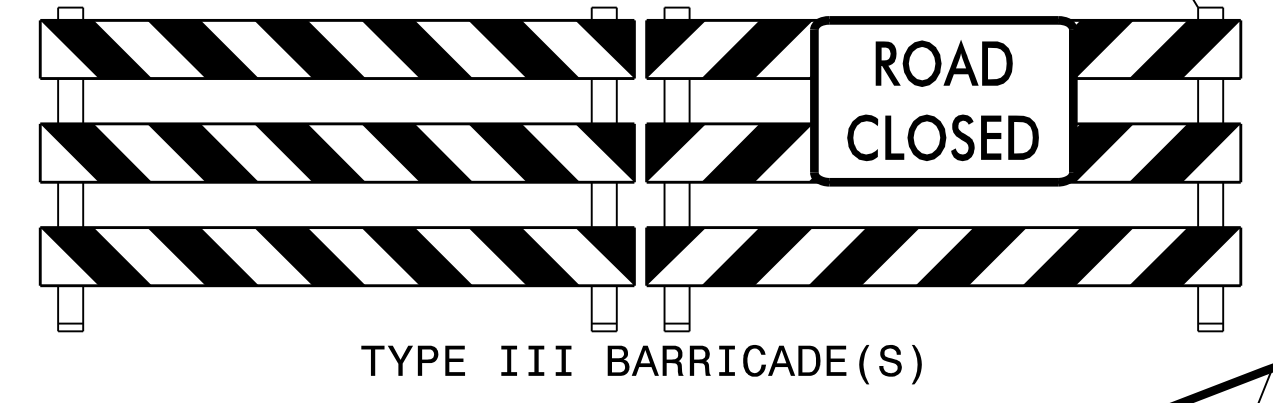
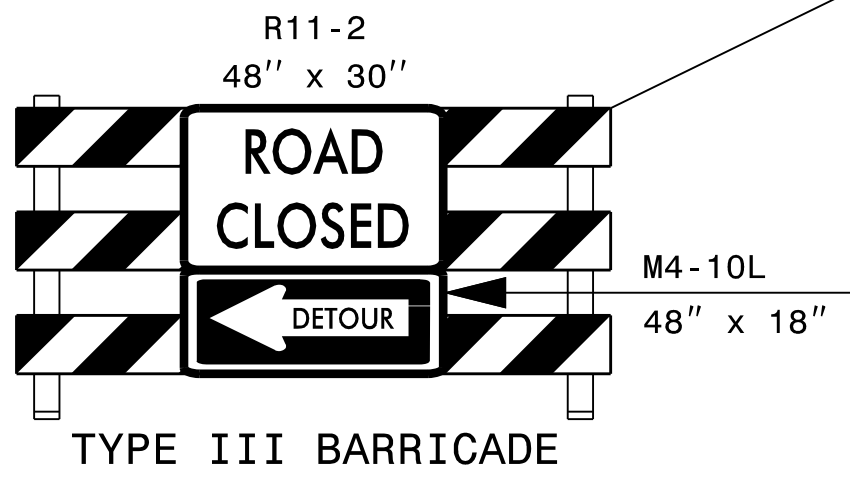

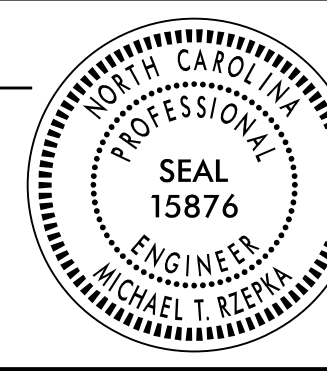
APPROVED: Michael T. Rzepka
DATE: 7/12/2022

SEAL
DOCUMENT NOT CONSIDERED FINAL UNLESS ALL SIGNATURES COMPLETED



**PHASE 1 - STEP 1B
DETOUR ROUTE FOR
BROADWAY RD CLOSURE
AT WOODLAND TRAILS RD
FOR PIPE WORK**

PLOT DRIVER: NCDOT_pdf_color_eng_50.pit PENTABLE: NCDOT_tcp.tbl
USER: CHARNDEN DATE: 5/4/2022 TIME: 10:45:07 AM
FILE: p:\p\h\p\usecases01\HDR_US_East_01\Documents\3322\10002133\10279033\6_0_CAD_BITMAP_6_2\IP\TrafficControl\CP\3830_TC_TMP-02C.dgn

REVISIONS

SIGN NUMBER: SP-02 **BACKG COLOR: Fluorescent Orange**
TYPE: STATIONARY **COPY COLOR: Black**
QUANTITY: SEE PLANS

SYMBOL	X	Y	WID	HT

SIGN WIDTH: 2'-6"
HEIGHT: 3'-0"
TOTAL AREA: 7.5 Sq.Ft.

BORDER TYPE: INSET
RECESS: 0.5"
WIDTH: 0.75"
RADII: 1.88"

MAT'L: 0.080" (2.0 mm) ALUMINUM

DESIGN BY: R Drayton **CHECKED BY: M Rzepka**
PROJECT ID: R-3830 **Sep 22, 2021**
DIV: 8

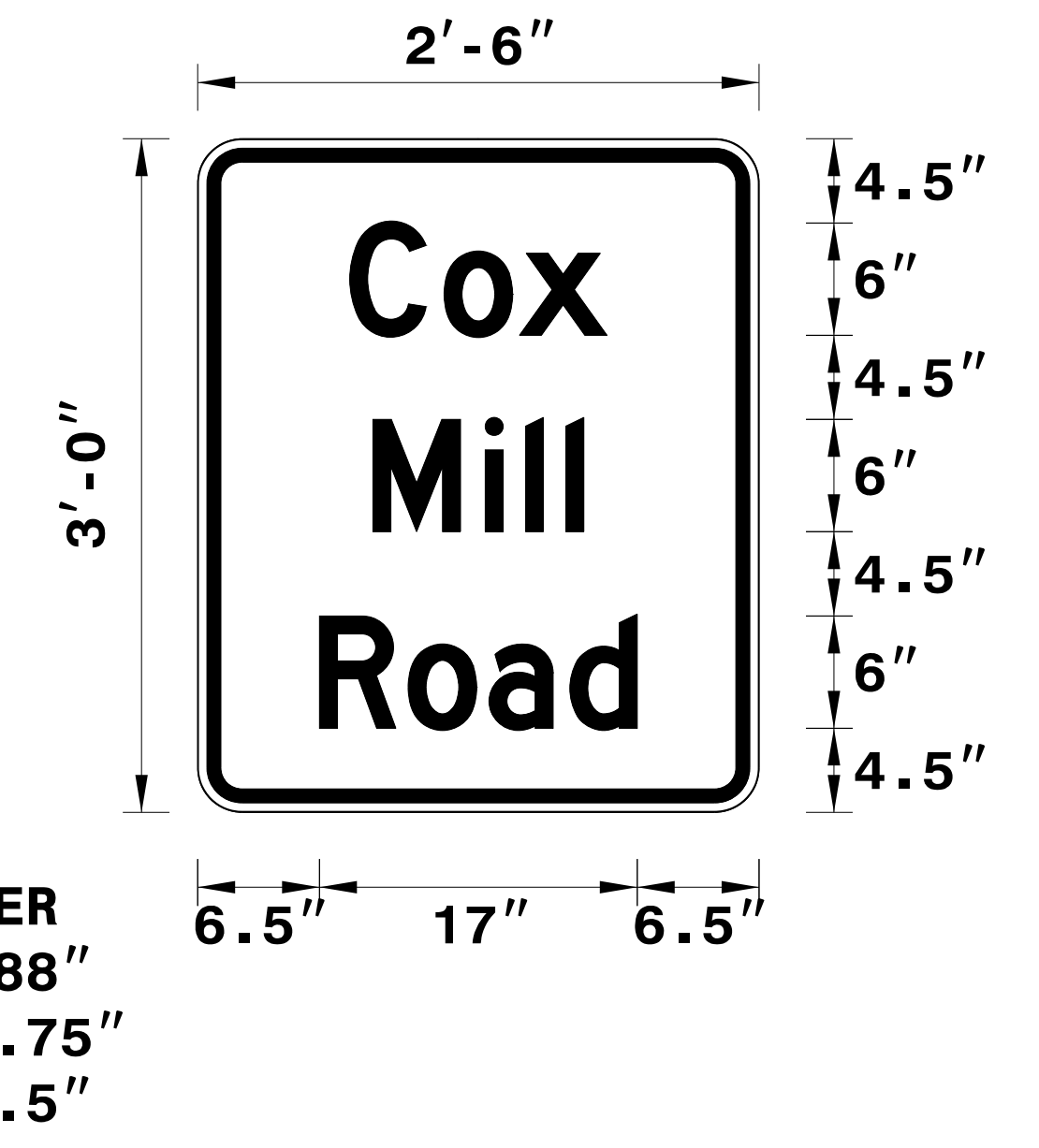

- USE NOTES: 1,2**
- 1. Legend and border shall be direct applied black non-reflective sheeting.
 - 2. Background shall be NC GRADE B fluorescent orange retroreflective sheeting.

Spacing Factor is 1 unless specified otherwise



LETTER POSITIONS

Letter spacings are to start of next letter								Series/Size
								Text Length
	C	o	x					D 2000
8.1	5	4	4.7	8.1				13.7
	M	i	l	l				D 2000
9.4	6	2.2	2.2	1	9.4			11.3
	R	o	a	d				D 2000
6.5	4.7	4.3	4.3	3.6	6.5			17

FILENAME: R3830_Sign_Designs

NORTH CAROLINA D.O.T. SIGN DETAIL

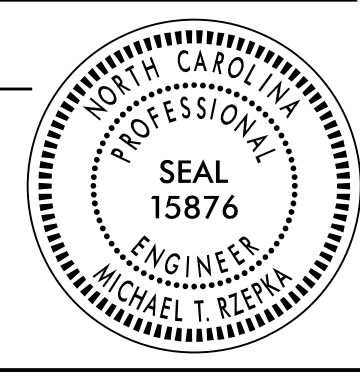
PLOT DRIVER: NCDOT_pdf_color_eng_50.pit PENTABLE: NCDOT_tcp.tbl
 USER: CHARNDEN DATE: 5/4/2022 TIME: 10:45:13 AM
 FILE: p:\pw\hdf\uses\01\HDF_US_East_01\Documents\3322\10002133\10279033\6_0_CAD_BITMAP\6.2.WIP\Traffic\TrafficControl\TCP\R3830_TC_TMP-02D.dgn

APPROVED: <i>Michael T. Rzepka</i> DATE: 7/12/2022 SEAL  DOCUMENT NOT CONSIDERED FINAL UNLESS ALL SIGNATURES COMPLETED		<p>SPECIAL SIGN DESIGN</p> <p>COX MILL RD</p>
--	---	---

PROJ. REFERENCE NO. R-3830	SHEET NO. TMP-4.01
 HDR Engineering, Inc. of the Carolinas 555 Fayetteville St, Suite 900 Raleigh, N.C. 27601 N.C.B.E.L.S. License Number: F-0116	

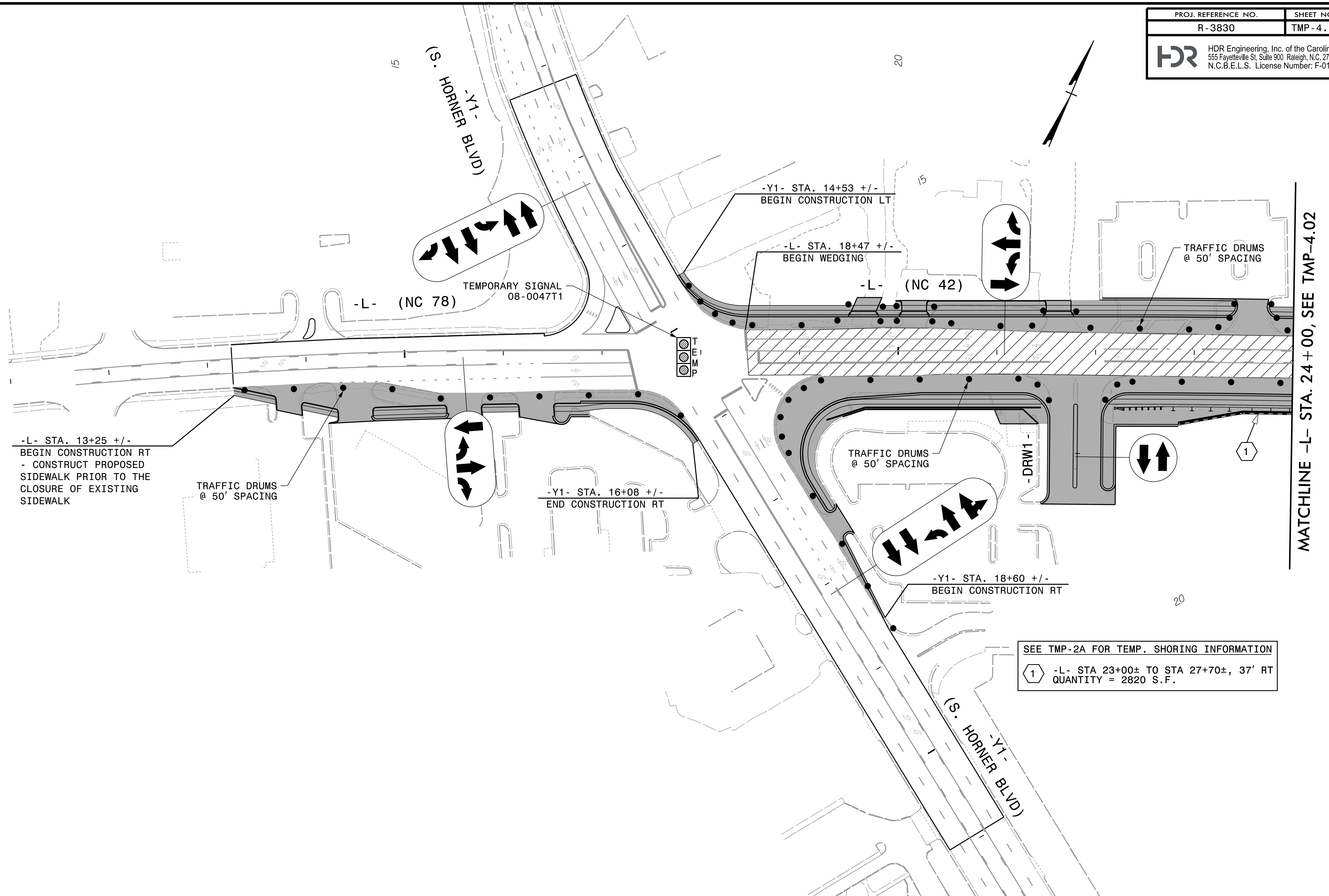

MATCHLINE -L- STA. 24+00, SEE TMP-4.02

-L- STA. 13+25 +/-
BEGIN CONSTRUCTION RT
- CONSTRUCT PROPOSED
SIDEWALK PRIOR TO THE
CLOSURE OF EXISTING
SIDEWALK

-Y1- STA. 14+53 +/-
BEGIN CONSTRUCTION LT

-L- STA. 18+47 +/-
BEGIN WEDGING

-L- (NC 42)



-Y1- STA. 16+08 +/-
END CONSTRUCTION RT

-Y1- STA. 18+60 +/-
BEGIN CONSTRUCTION RT

SEE TMP-2A FOR TEMP. SHORING INFORMATION
 1 -L- STA 23+00± TO STA 27+70±, 37' RT
 QUANTITY = 2820 S.F.

PLOT DRIVER: NCDOT_pdf_color_eng_50.plt
 USER: CHARNDEN
 DATE: 5/4/2022
 PENTABLE: NCDOT_tcp.tbl
 TIME: 10:45:27 AM
 FILE: p:\p\p\h\p\uses\01\h\p\us_e\ost_01\Documents\3322\10002133\10279033\6_0_CAD.BIM\6.2.WIP\TrafficControl\TCP\R3830_TC_TMP-04.01.dgn

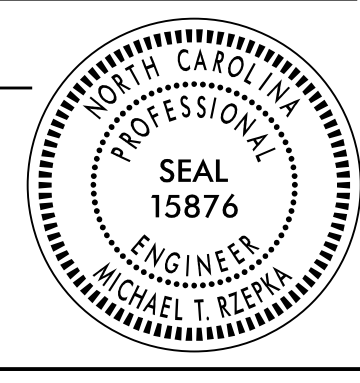
REVISIONS

APPROVED: <i>Michael T. Rzepka</i> DATE: 7/12/2022 SEAL			<p>PHASE 1 - STEP 1</p>
DOCUMENT NOT CONSIDERED FINAL UNLESS ALL SIGNATURES COMPLETED			

PROJ. REFERENCE NO. R - 3830	SHEET NO. TMP - 4.03
 HDR Engineering, Inc. of the Carolinas 555 Fayetteville St, Suite 900 Raleigh, N.C. 27601 N.C.B.E.L.S. License Number: F-0116	

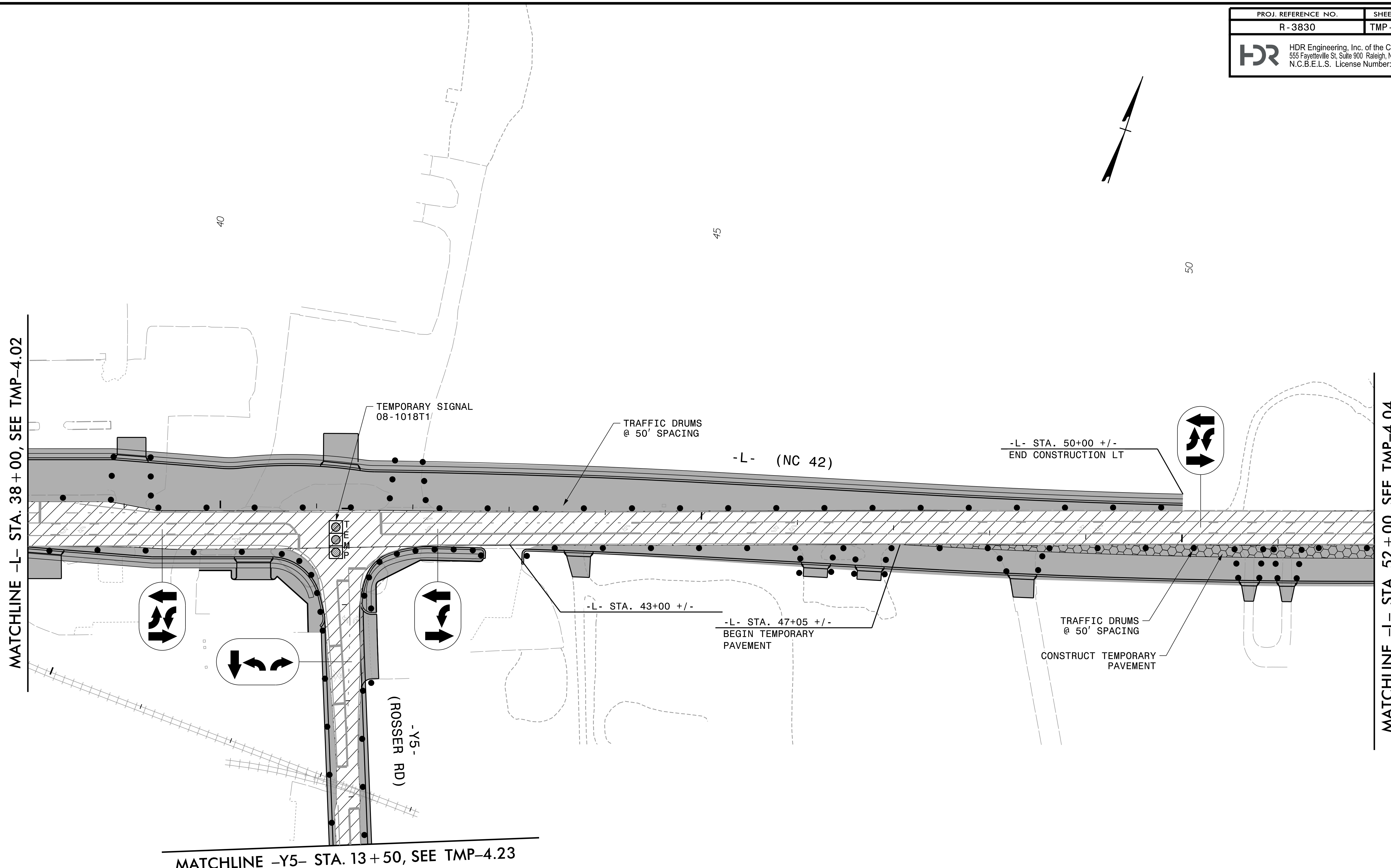
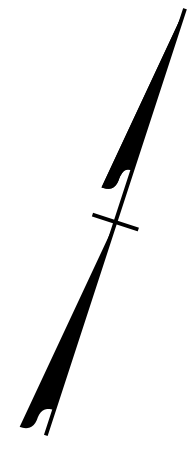

REVISIONS

PLOT DRIVER: NCDOT_pdf_color_eng_50.pit
 USER: CHARNDEN
 DATE: 5/4/2022
 TIME: 10:45:42 AM
 FILE: p:\p\h\p\users\charnden\us_east_01\Documents\3322\10002133\10279033\6_0_CAD_BIM\6.2_WIP\TrafficControl\CP\3830_TC_TMP-04.03.dgn

APPROVED: *Michael T. Rzepka*

DATE: 7/12/2022

SEAL

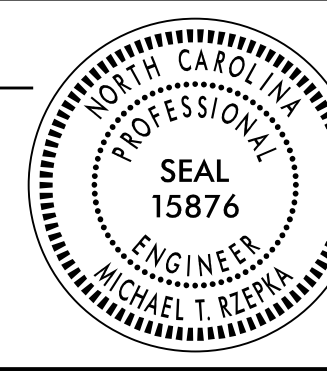

**DOCUMENT NOT CONSIDERED FINAL
UNLESS ALL SIGNATURES COMPLETED**

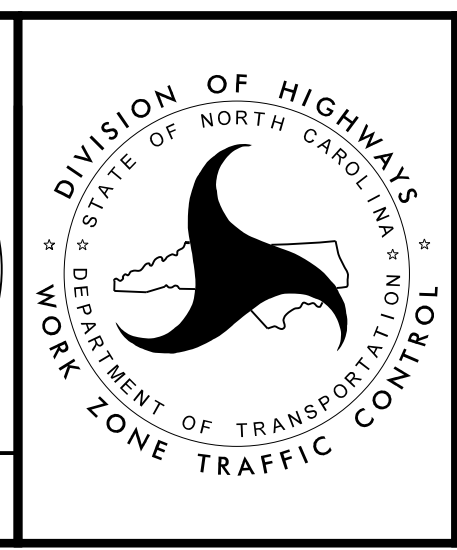

PHASE 1 - STEP 1

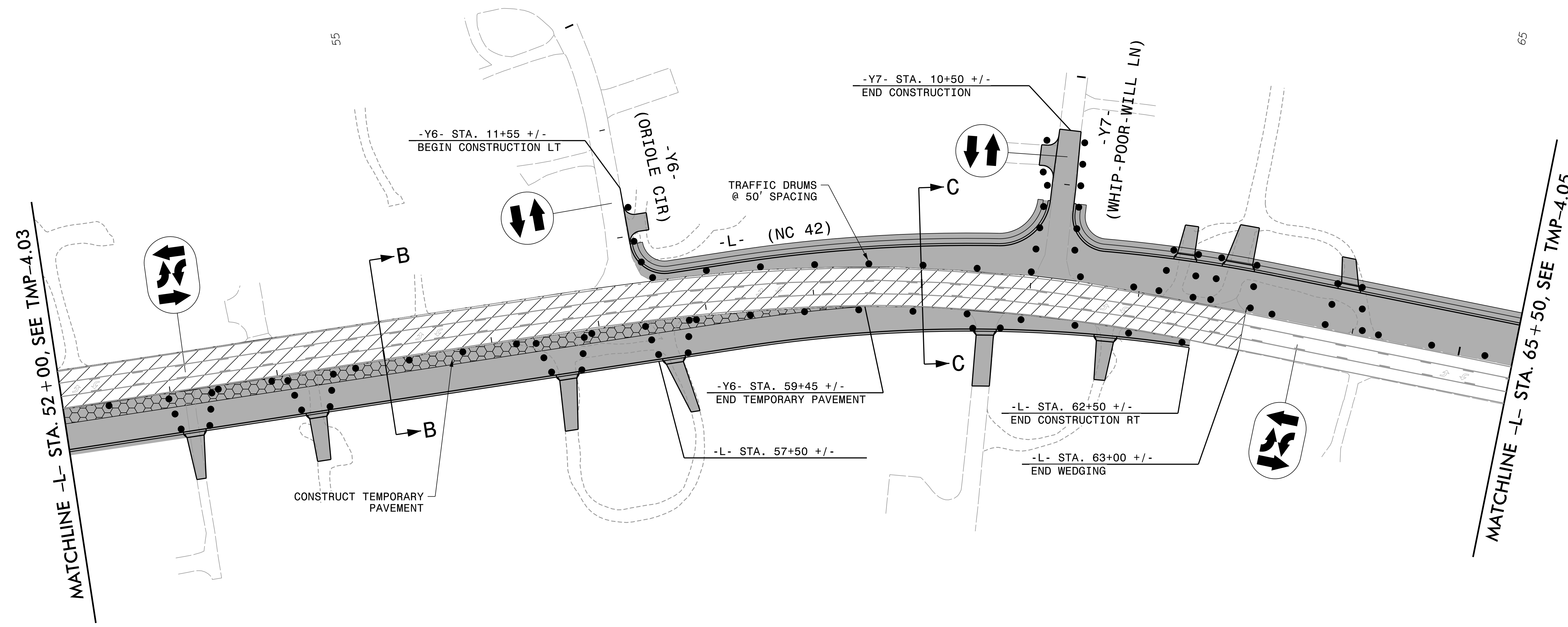
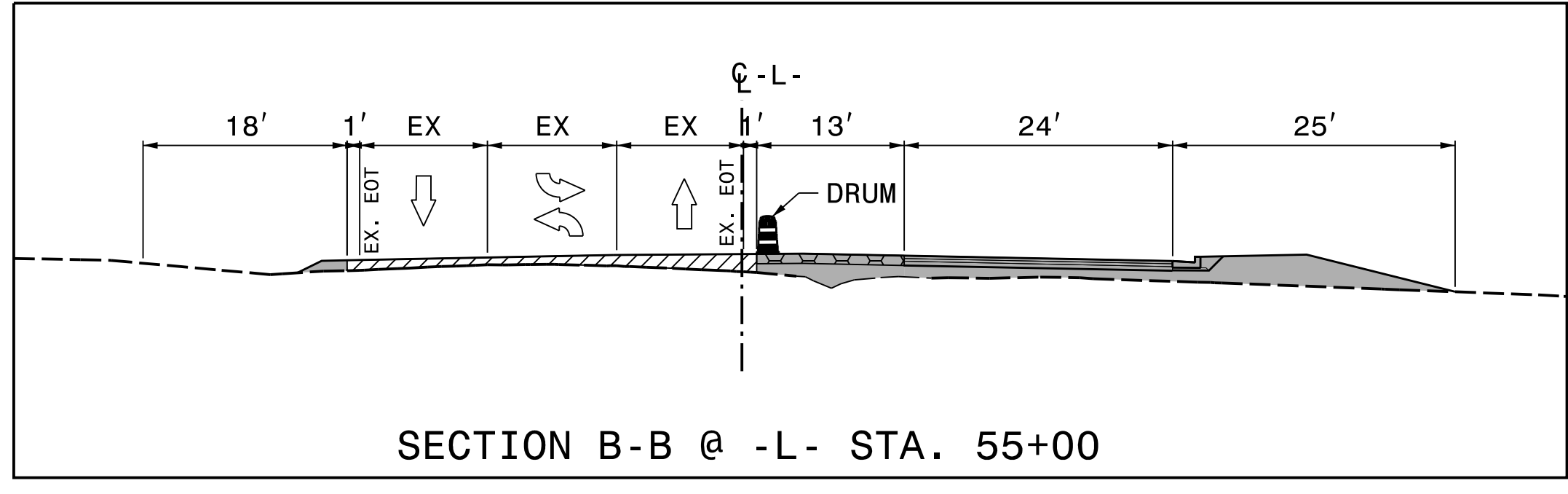
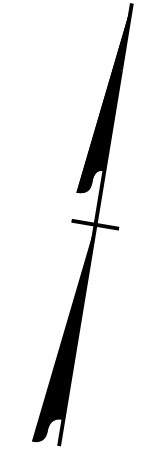

REVISIONS

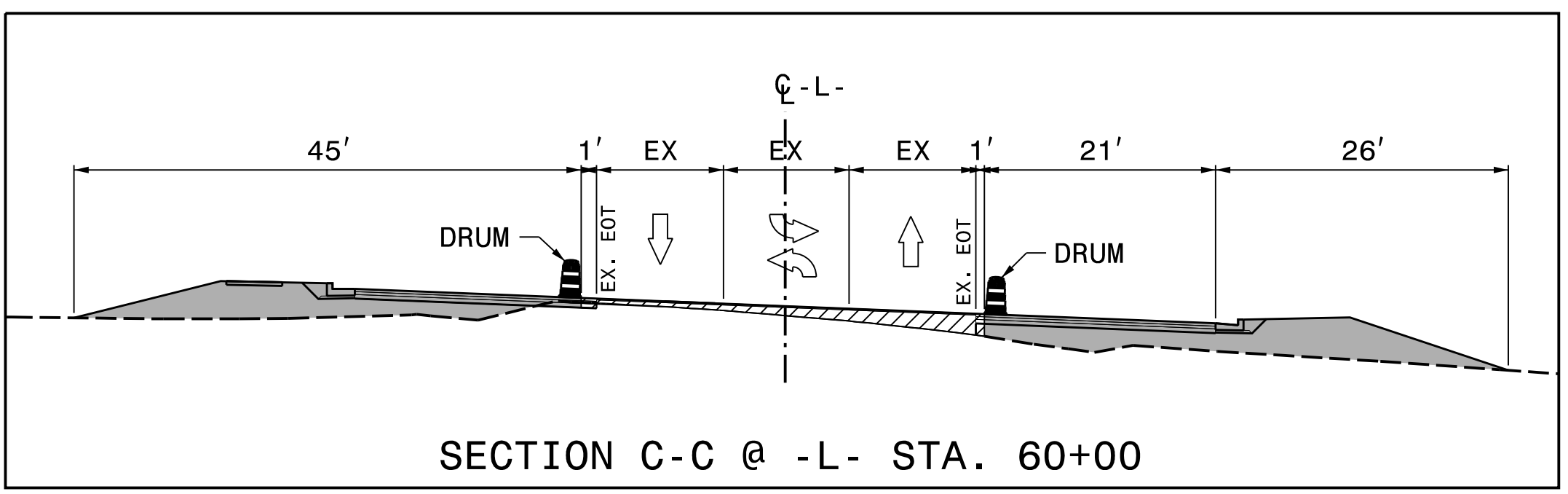

PLOT DRIVER: NCDOT_pdr_color_eng_50.plt
 USER: CHARNDEN
 DATE: 5/4/2022
 TIME: 10:45:49 AM
 FILE: p:\p\pdr\uses01\HDR_US_East_01\Documents\3322\10002133\10279033\6_0_CAD_BITMAP\6_2_WIP\Traffic/TrafficControl\TCP\R3830_TC_TMP-04.dgn

APPROVED: Michael T. Rzepka

DATE: 7/12/2022

SEAL

PROFESSIONAL SEAL 15876
 ENGINEER
 MICHAEL T. RZEPKA

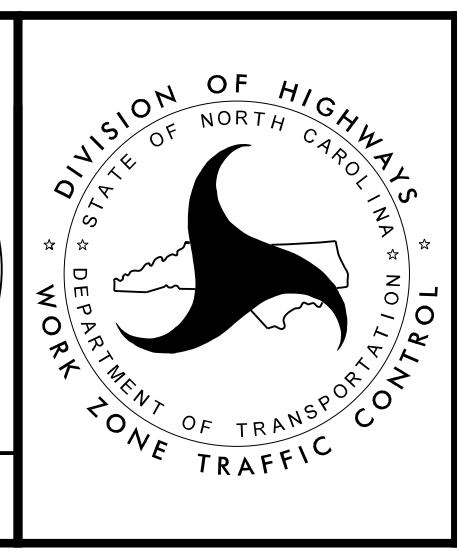

PHASE 1 - STEP 1

DOCUMENT NOT CONSIDERED FINAL
 UNLESS ALL SIGNATURES COMPLETED

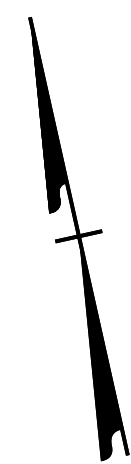

PLOT DRIVER: NCDOT_pdf_color_eng_50.plt PENTABLE: NCDOT_tcp.tbl
 USER: CHARNDEN DATE: 5/4/2022 TIME: 10:45:57 AM
 FILE: p:\pwhdr\users\01\HDR-US-East_01\Documents\3322\10002133\10279033\6_0_CAD_BIM\6.2_WIP\Traffic\TrafficControl\CP\3830_TC_TMP-04.05.dgn

REVISIONS

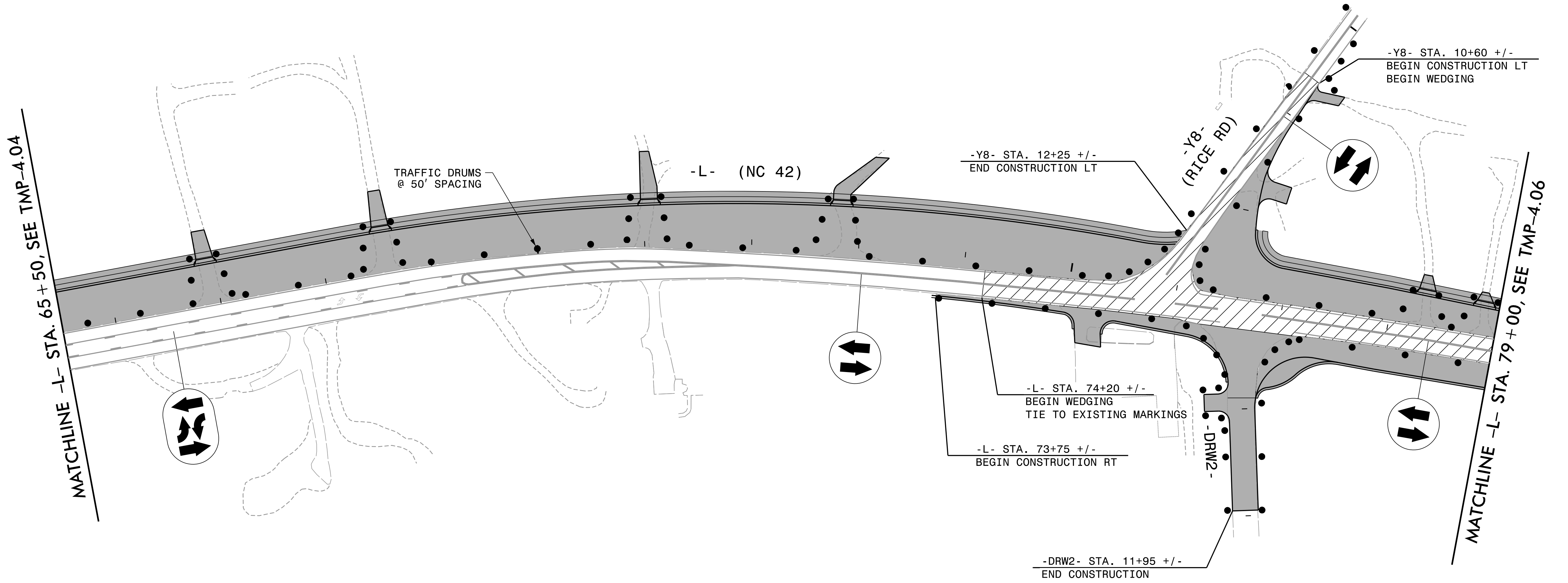

APPROVED: Michael T. Respha
 DATE: 7/12/2022
 SEAL

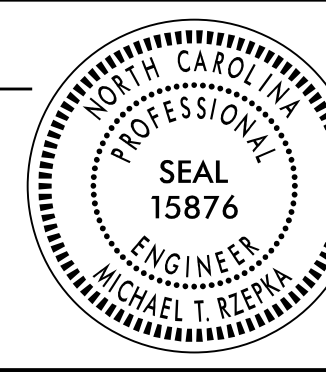
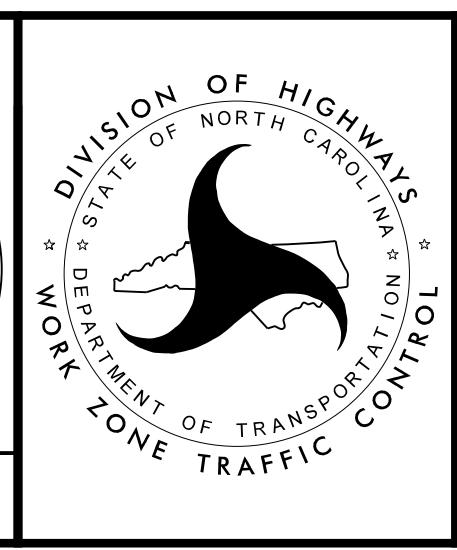



PHASE 1 - STEP 1

**DOCUMENT NOT CONSIDERED FINAL
UNLESS ALL SIGNATURES COMPLETED**

PLOT DRIVER: NCDOT_pdf_color_eng_50.pit
PENTABLE: NCDOT_tcp.tbl
USER: CHARNDEN
DATE: 5/4/2022
TIME: 10:46:05 AM
FILE: p:\p\hndr\users\charnd\us_east_01\Documents\3322\10002133\10279033\6_0_CAD_BITMAP\6.2_WIP\Traffic\TrafficControl\TCP\R3830_TC_TMP-04.dgn

REVISIONS

PROJ. REFERENCE NO. R - 3830	SHEET NO. TMP - 4.06
 HDR Engineering, Inc. of the Carolinas 555 Fayetteville St, Suite 900 Raleigh, N.C. 27601 N.C.B.E.L.S. License Number: F-0116	

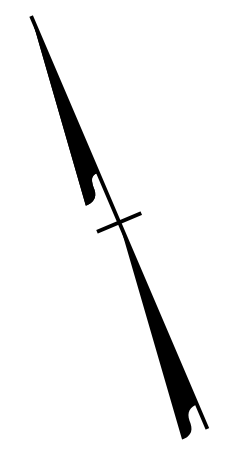

MATCHLINE -L- STA. 79 + 00, SEE TMP-4.05

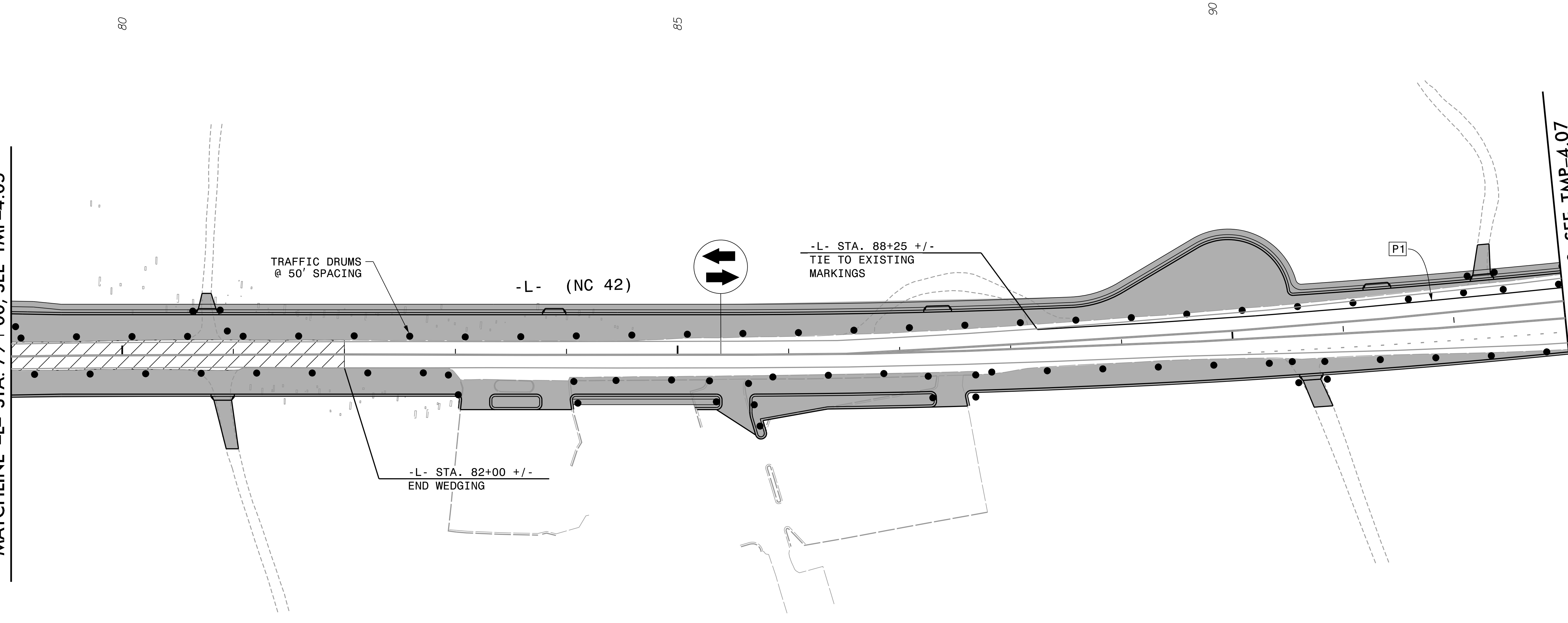

MATCHLINE -L- STA. 93 + 00, SEE TMP-4.07

APPROVED: *Michael T. Rzepka*

DATE: 7/12/2022

SEAL

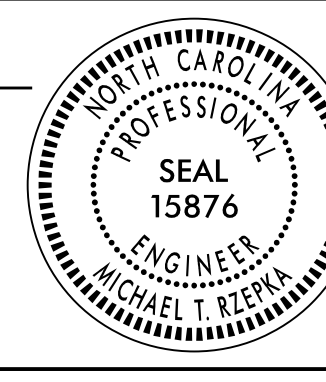

**DOCUMENT NOT CONSIDERED FINAL
UNLESS ALL SIGNATURES COMPLETED**

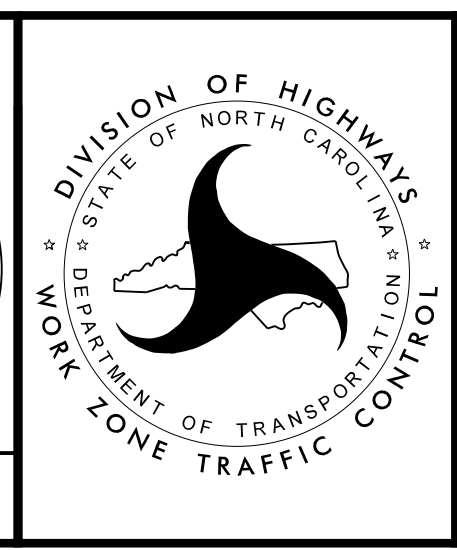

PHASE 1 - STEP 1

PROJ. REFERENCE NO. R-3830	SHEET NO. TMP-4.07
 HDR Engineering, Inc. of the Carolinas 555 Fayetteville St., Suite 900 Raleigh, N.C. 27601 N.C.B.E.L.S. License Number: F-0116	

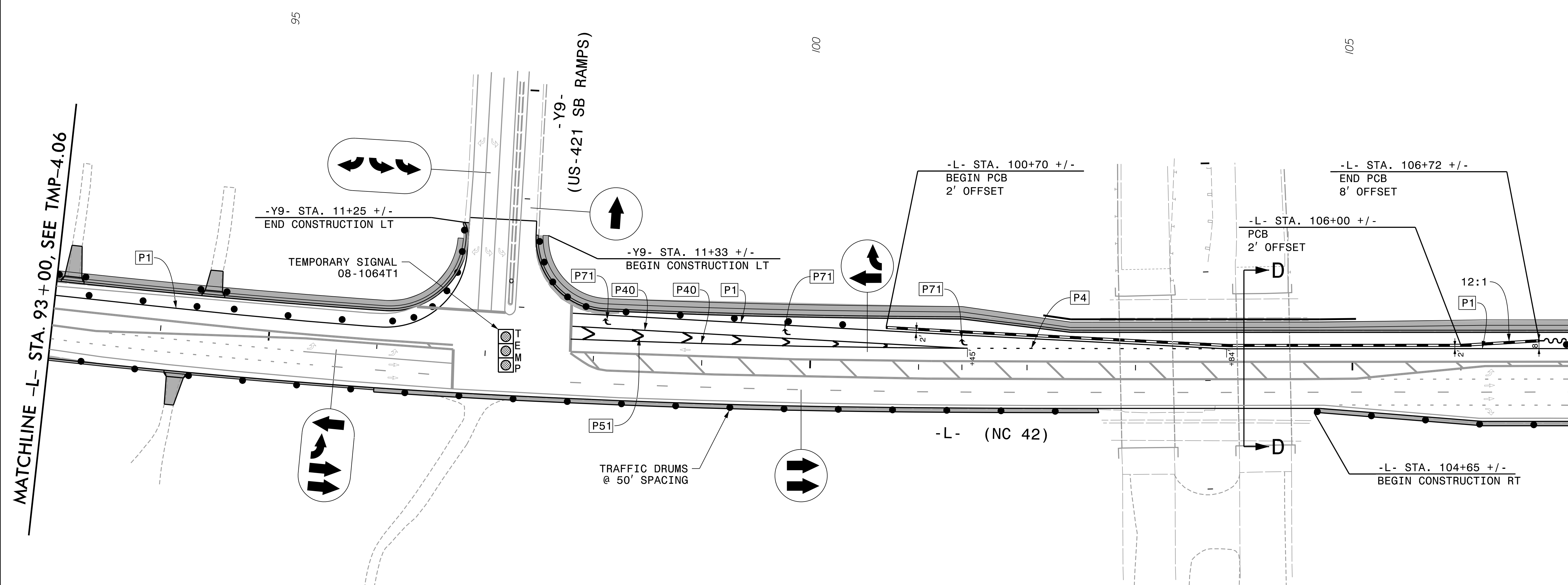
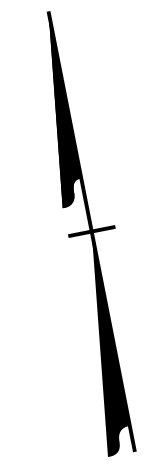

REVISIONS

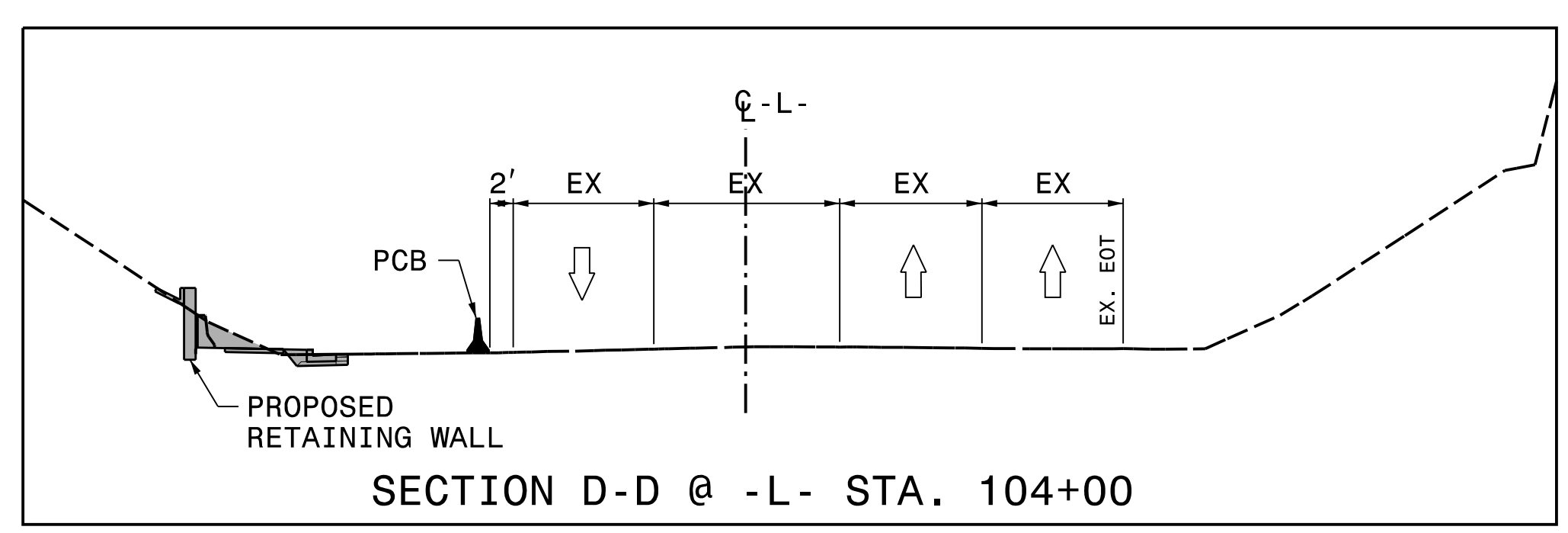

PLOT DRIVER: NCDOT_color_eng_50.plt
 USER: CHARNDEN
 DATE: 5/4/2022
 PENTABLE: NCDOT_color.tbl
 TIME: 10:46:13 AM
 FILE: p:\p\pdr\users\charnden\US_East_01\Documents\3322\10002133\10279033\6_0_CAD.BIM\6.2.WIP\TrafficControl\CPA\3830_TC_TMP-04.07.dgn

APPROVED: *Michael T. Ryopha*
 DATE: 7/12/2022

SEAL

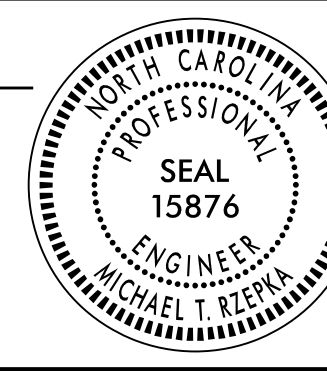

PHASE 1 - STEP 1

DOCUMENT NOT CONSIDERED FINAL
 UNLESS ALL SIGNATURES COMPLETED

PLOT DRIVER: NCDOT_pdf_color_eng_50.pit
 USER: CHARNDEN
 DATE: 5/4/2022
 TIME: 10:46:21 AM
 FILE: p:\pw\hdf\users\charnd\US_East_01\Documents\3322\10002133\10279033\6_0_CAD_BITMAP\6.2_WIP\TrafficControl\TCP\R3830_TC_TMP-04.dgn

REVISIONS

PROJ. REFERENCE NO.	SHEET NO.
---------------------	-----------

R-3830	TMP-4.08
--------	----------



HDR Engineering, Inc. of the Carolinas
 555 Fayetteville St, Suite 900 Raleigh, N.C. 27601
 N.C.B.E.L.S. License Number: F-0116

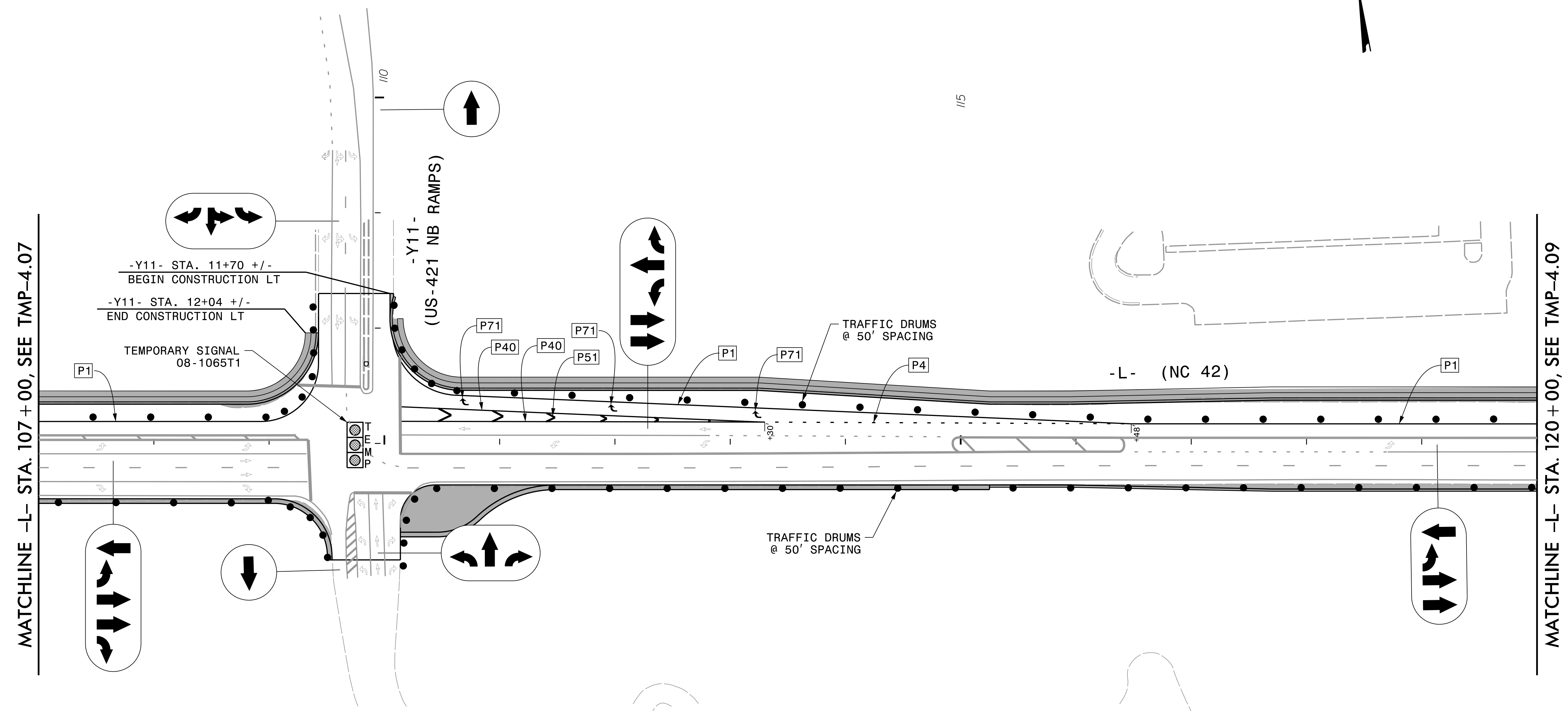

PENTABLE: NCDOT_tcp.tbl
 TIME: 10:46:21 AM

APPROVED: *Michael T. Riepha*

DATE: 7/12/2022

SEAL

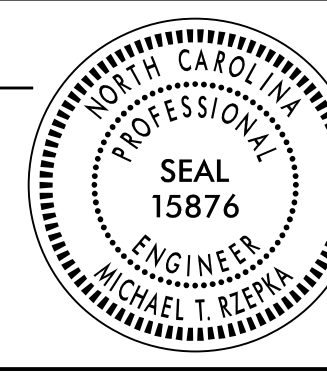

DOCUMENT NOT CONSIDERED FINAL UNLESS ALL SIGNATURES COMPLETED

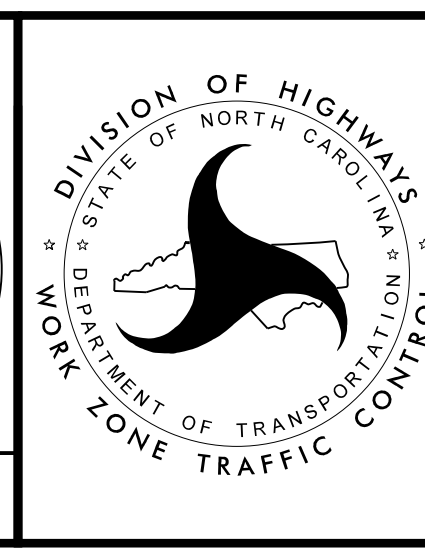

PHASE 1 - STEP 1

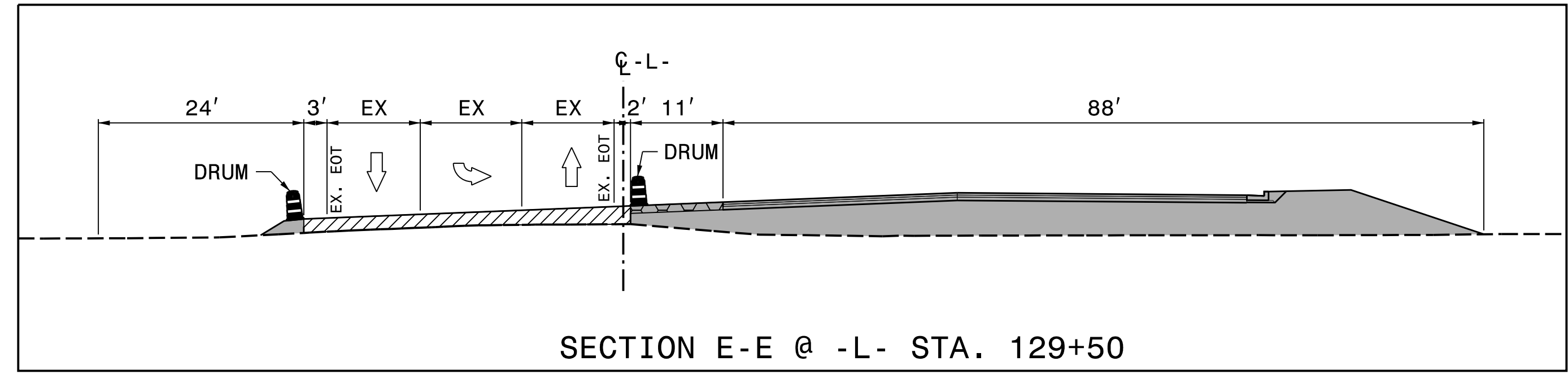
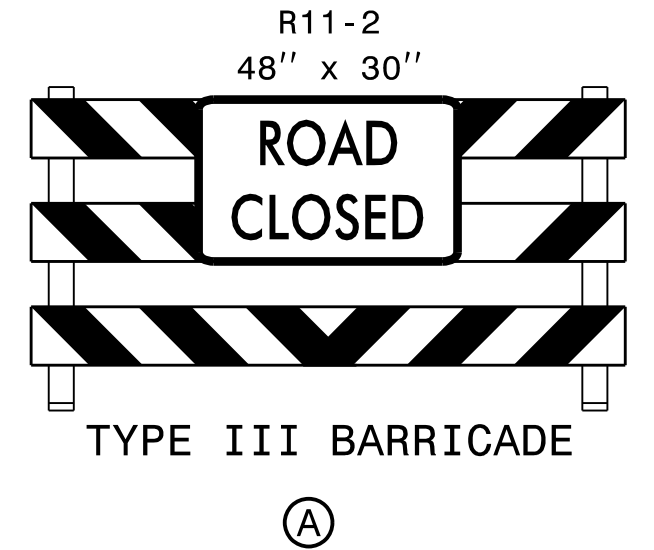
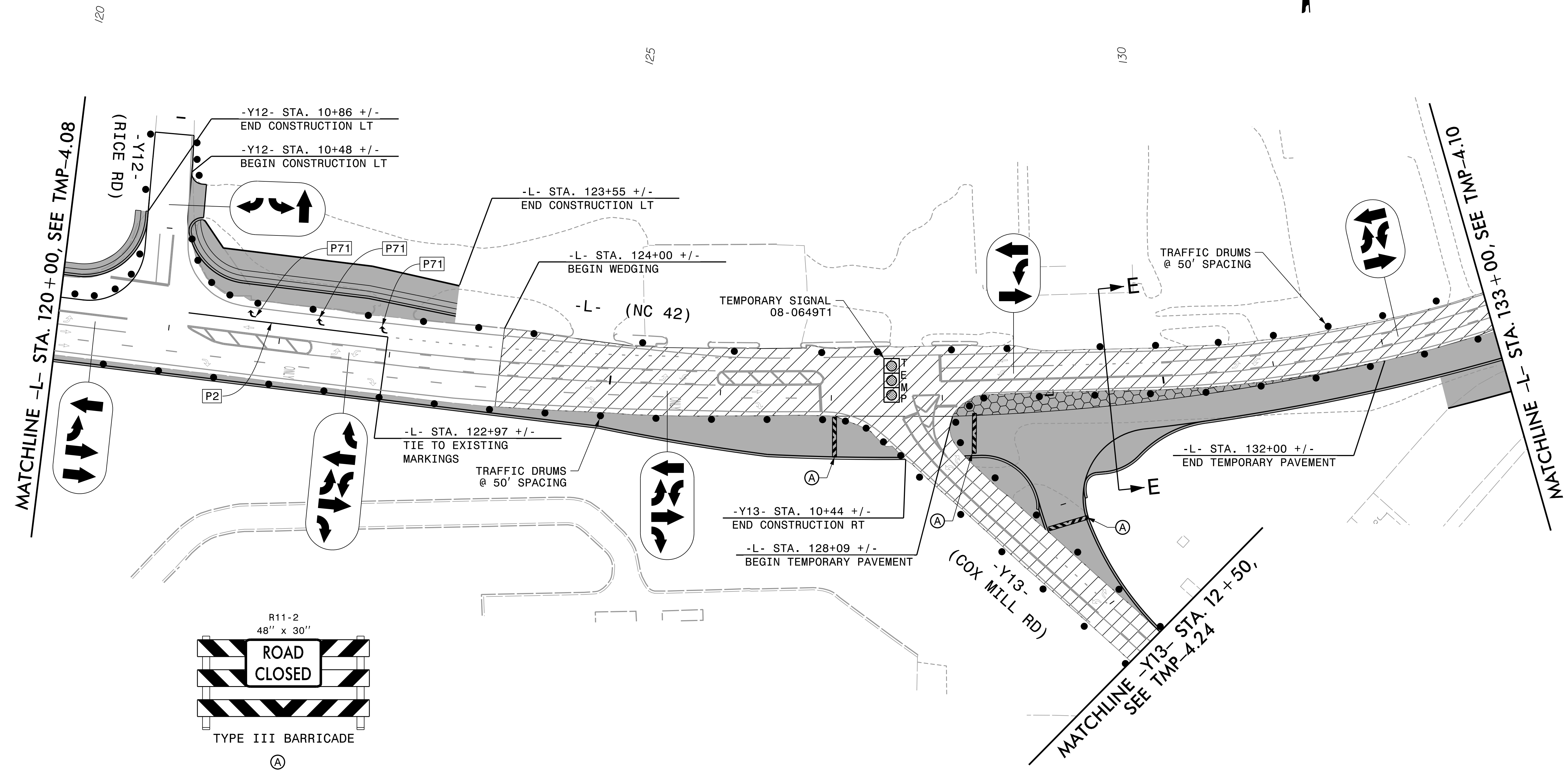

APPROVED: *Michael T. Rzepka*

DATE: 7/12/2022

SEAL

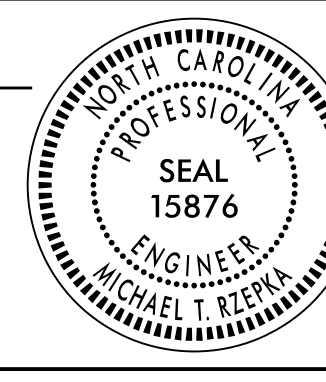

**DOCUMENT NOT CONSIDERED FINAL
UNLESS ALL SIGNATURES COMPLETED**



PHASE 1 - STEP 1

PLOT DRIVER: NCDOT_pdf_color_eng_50.plt
 USER: CHARNDEN
 DATE: 5/4/2022
 TIME: 10:46:29 AM
 FILE: p:\p\h\p\users\01\h\p\us\East_01\Documents\3322\10002133\10279033\6_0_CAD_BITMAP\6.2_WIP\TrafficControl\TCP\R3830_TC_TMP-04_09.dgn

REVISIONS

PROJ. REFERENCE NO.	SHEET NO.
R - 3830	TMP - 4.10
 HDR Engineering, Inc. of the Carolinas 555 Fayetteville St, Suite 900 Raleigh, N.C. 27601 N.C.B.E.L.S. License Number: F-0116	

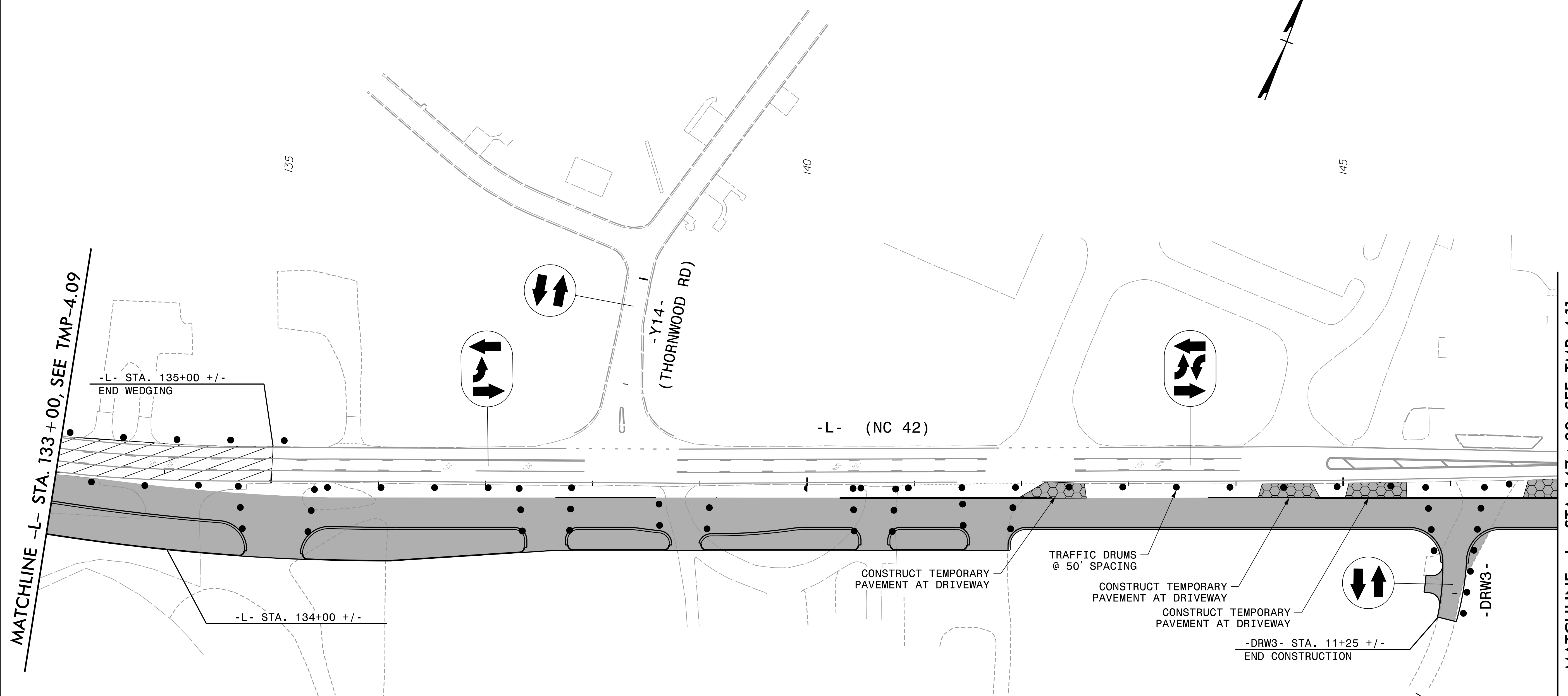

REVISIONS

PLOT DRIVER: NCDOT_pdf_color_eng_50.pit
 USER: CHARNDEN
 DATE: 5/4/2022
 TIME: 10:46:37 AM
 FILE: p:\pwhdr\uses01\HDR_US_East_01\Documents\3322\10002133\10279033\6_0_CAD_BIM\6.2_WIP\Traffic\TrafficControl\CPA\R3830_TC_TMP-04.10.dgn

APPROVED: *Michael T. Rzepka*

DATE: 7/12/2022

SEAL

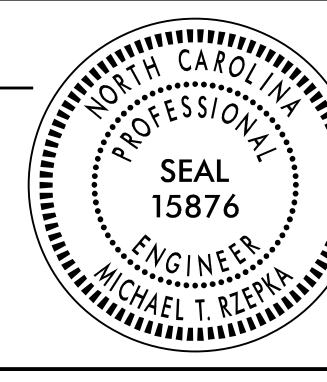

**DOCUMENT NOT CONSIDERED FINAL
UNLESS ALL SIGNATURES COMPLETED**



SEAL

PHASE 1 - STEP 1

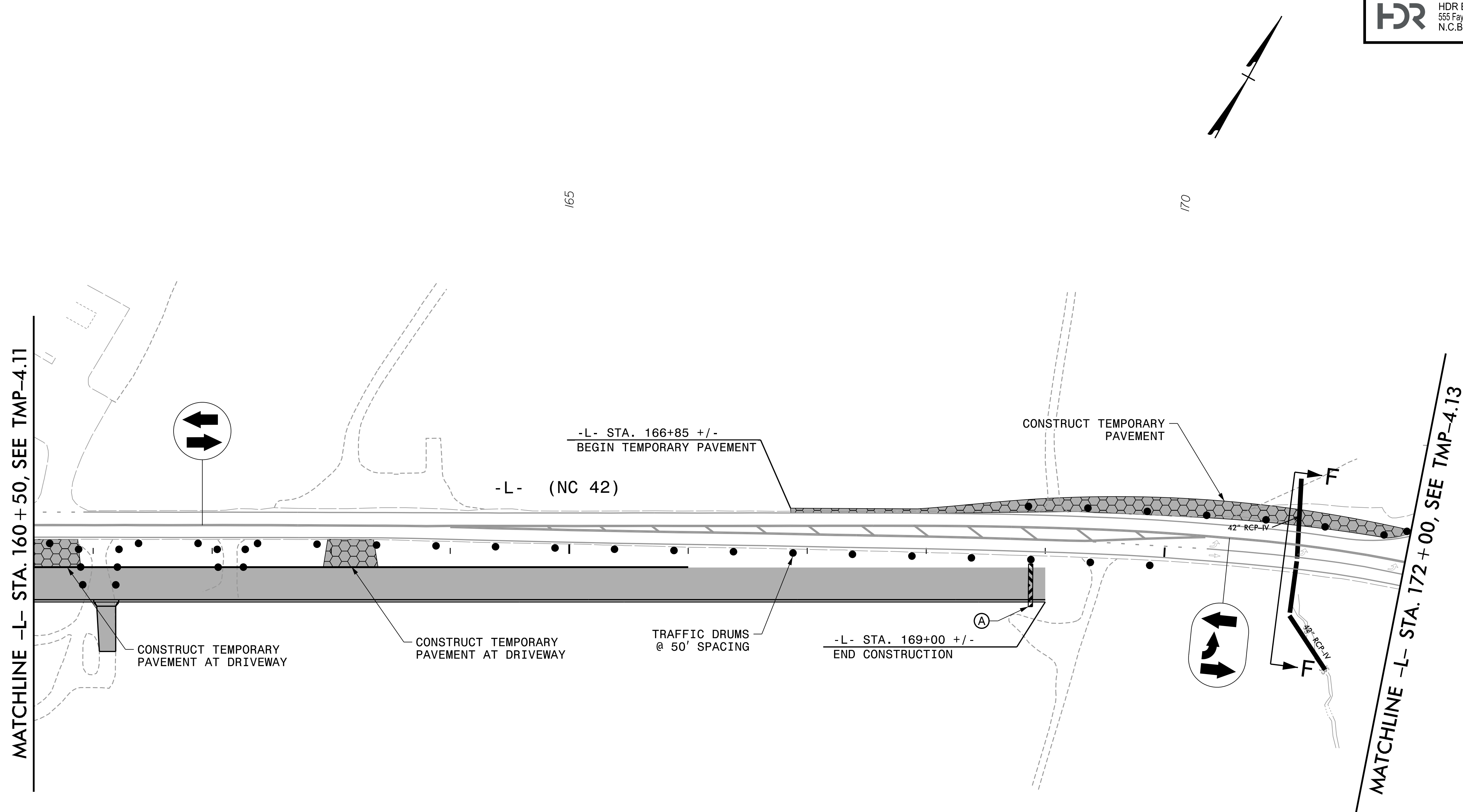

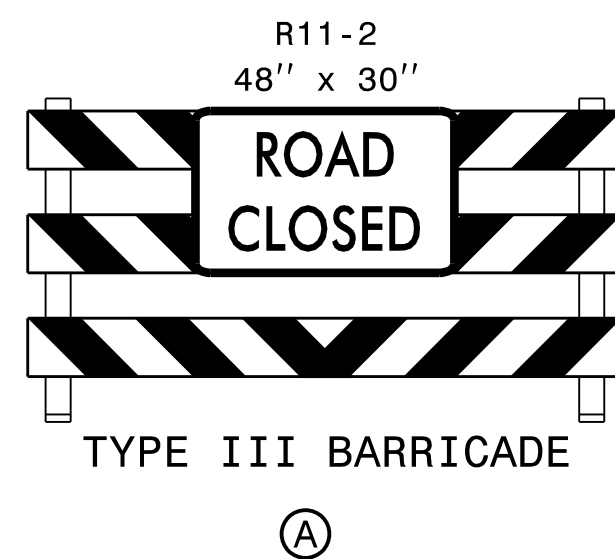
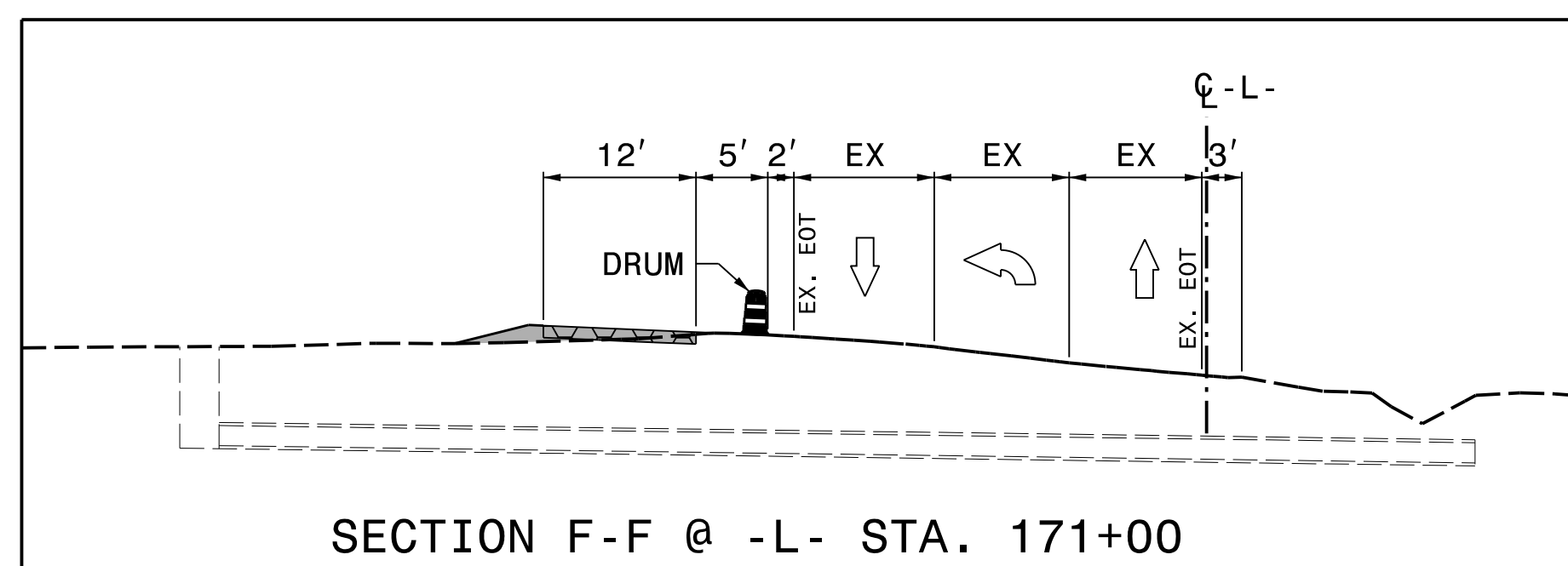

REVISIONS

PLOT DRIVER: NCDOT_pdf_color_eng_50.pit
 USER: CHARNDEN
 DATE: 5/4/2022
 PENTABLE: NCDOT_tcp.tbl
 TIME: 10:46:52 AM
 FILE: pw:\pwhdr\usecase01\HDR_US_Eost.01\Documents\3322\10002133\10279033\6_0_CAD.BITM\6.2.WIP\TrafficControl\TCP\3830_TC_TMP-04.12.dgn

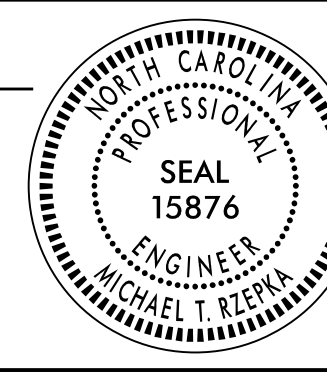

APPROVED: *Michael T. Rzepka*
 DATE: 7/12/2022
 SEAL





PHASE 1 - STEP 1



**DOCUMENT NOT CONSIDERED FINAL
UNLESS ALL SIGNATURES COMPLETED**

PLOT DRIVER: NCDOT_pdf_color_eng_50.pit
 USER: CHARNDEN
 DATE: 5/4/2022
 PENTABLE: NCDOT_tcp.tbl
 TIME: 10:47:01 AM
 FILE: p:\pwhdr\users\01\hfr_us_east_01\Documents\3322\10002133\10279033\6_0_CAD.BIM\6.2.WIP\Traffic\TrafficControl\TCP\R3830_TC_TMP-04.13.dgn

REVISIONS

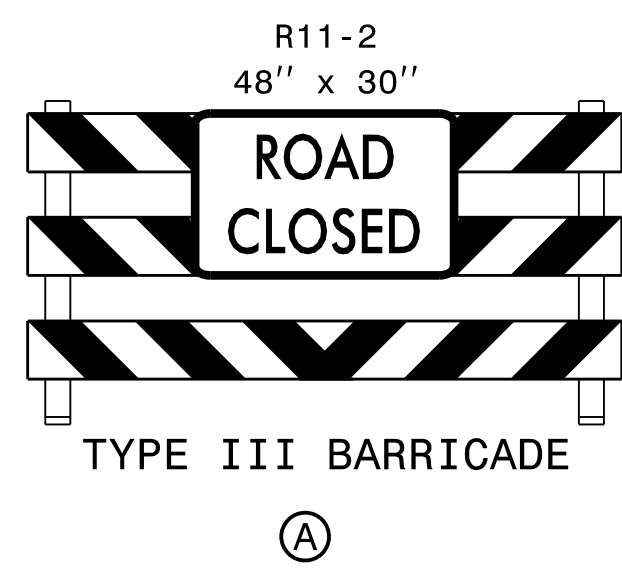
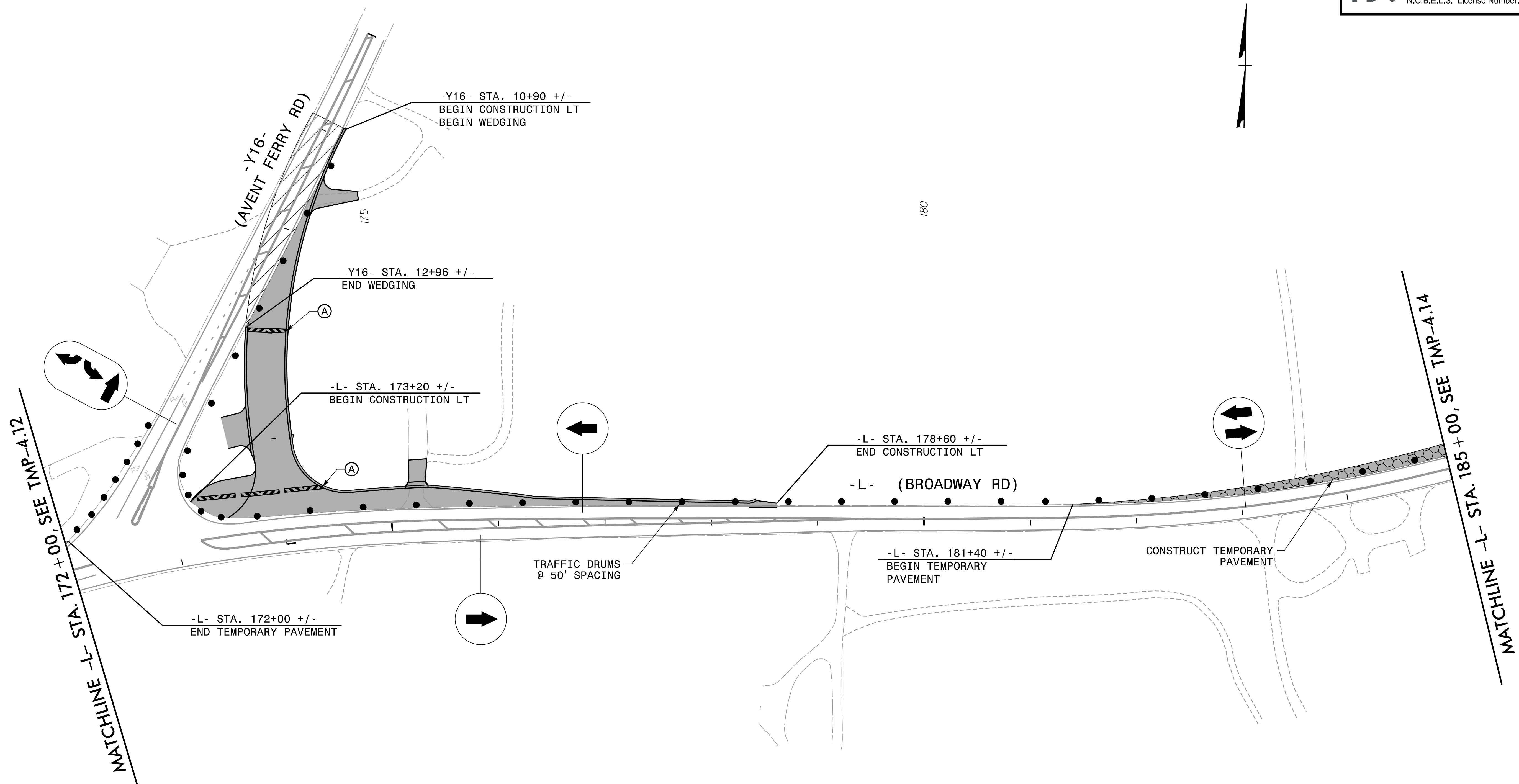
PROJ. REFERENCE NO.	SHEET NO.
R-3830	TMP-4.13
 HDR Engineering, Inc. of the Carolinas 555 Fayetteville St, Suite 900 Raleigh, N.C. 27601 N.C.B.E.L.S. License Number: F-0116	

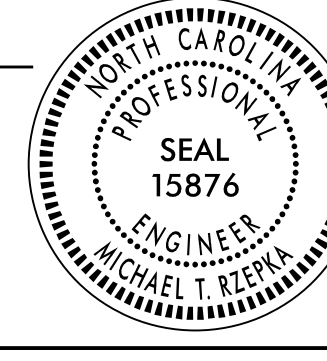

APPROVED: <i>Michael T. Ryepka</i>		
DATE: 7/12/2022		
<p>DOCUMENT NOT CONSIDERED FINAL UNLESS ALL SIGNATURES COMPLETED</p>		<p>PHASE 1 - STEP 1</p>

PROJ. REFERENCE NO. R - 3830	SHEET NO. TMP - 4.14
 HDR Engineering, Inc. of the Carolinas 555 Fayetteville St, Suite 900 Raleigh, N.C. 27601 N.C.B.E.L.S. License Number: F-0116	

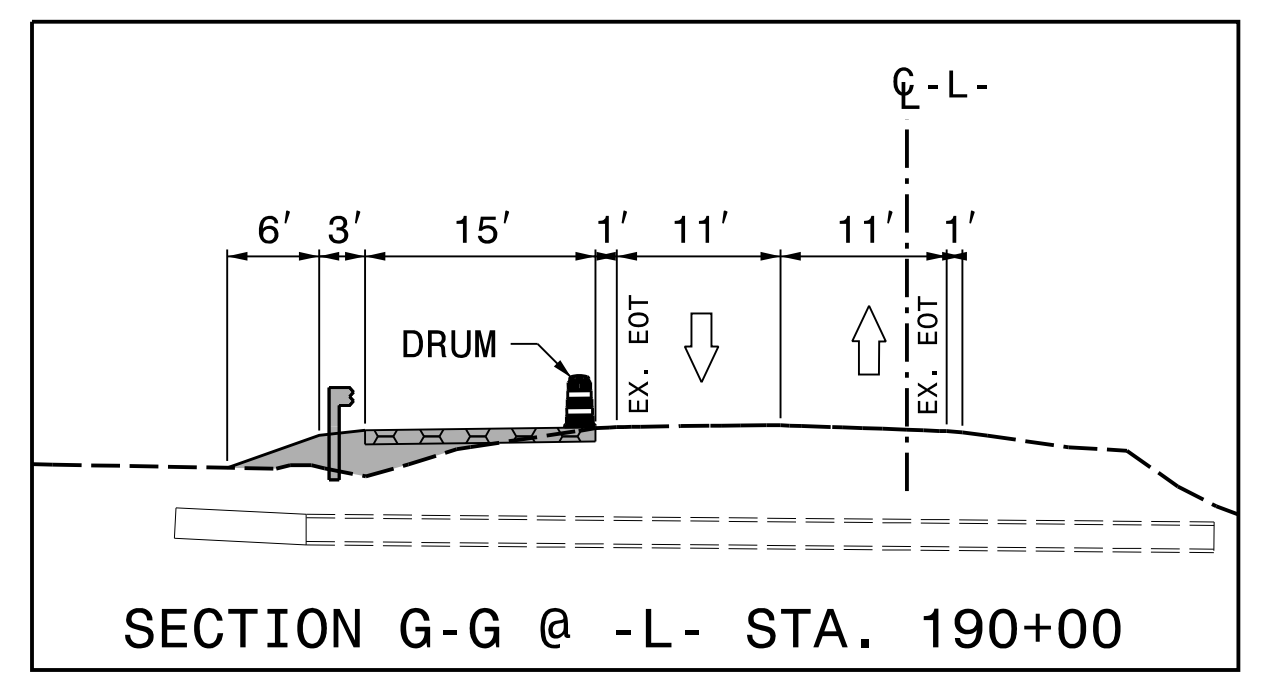
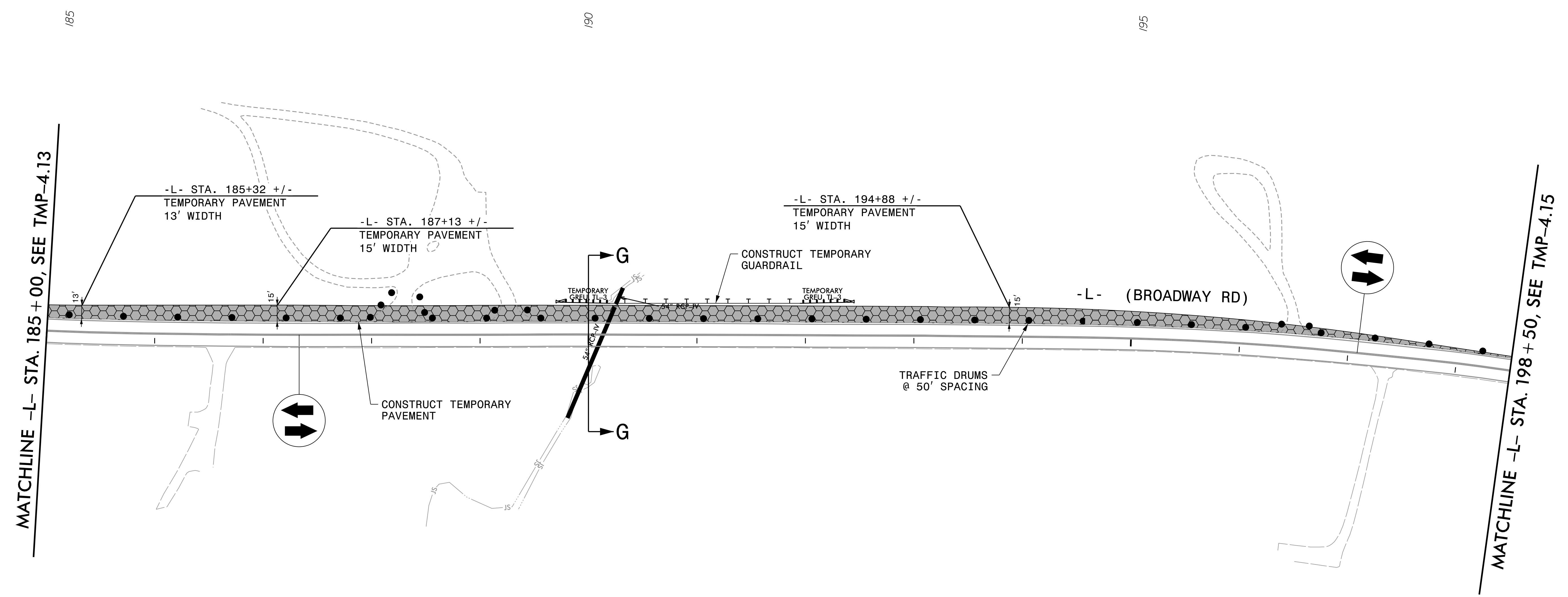
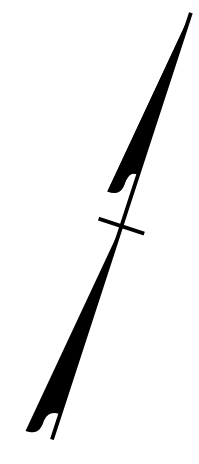

MATCHLINE -L- STA. 185+00, SEE TMP-4.13

MATCHLINE -L- STA. 198+50, SEE TMP-4.15

REVISIONS

PLOT DRIVER: NCDOT_pdf_color_eng_50.plt
 USER: CHARNDEN
 DATE: 5/4/2022
 TIME: 10:47:09 AM
 FILE: pw:\pwhdr\users\01\hdf-us-east\01\Documents\3322\10002133\10279033\6_0_CAD.BIM\6_2_WIP\TrafficControl\CP\R3830_TC_TMP-04.14.dgn

APPROVED: *Michael T. Rzepka*
 DATE: 7/12/2022
 SEAL

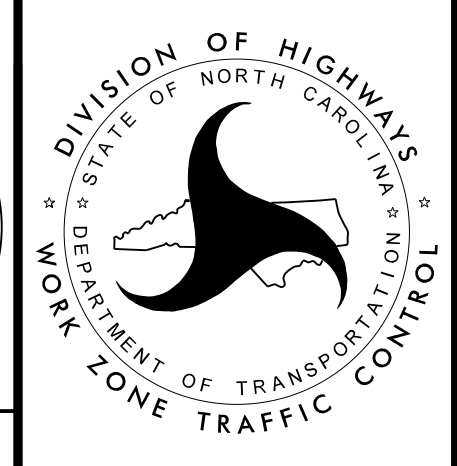
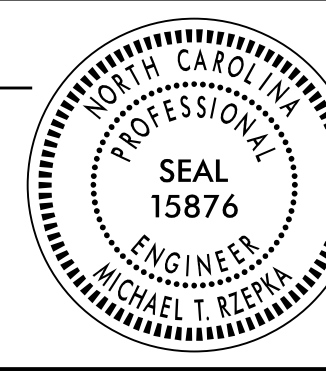

PHASE 1 - STEP 1

DOCUMENT NOT CONSIDERED FINAL
UNLESS ALL SIGNATURES COMPLETED

REVISIONS

PROJ. REFERENCE NO.	SHEET NO.
R - 3830	TMP - 4.16
 HDR Engineering, Inc. of the Carolinas 555 Fayetteville St, Suite 900 Raleigh, N.C. 27601 N.C.B.E.L.S. License Number: F-0116	

MATCHLINE -L- STA. 212 + 00, SEE TMP-4.15

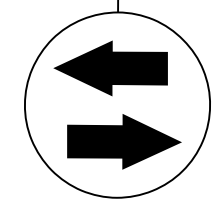

-L- STA. 214+00 +/-
END TEMPORARY PAVEMENT



-L- (BROADWAY RD)

-L- STA. 214+00 +/-
BEGIN CONSTRUCTION RT
BEGIN WEDGING

TRAFFIC DRUMS
@ 50' SPACING

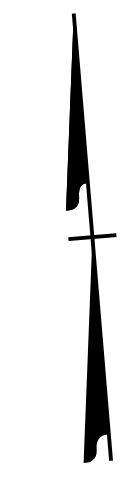
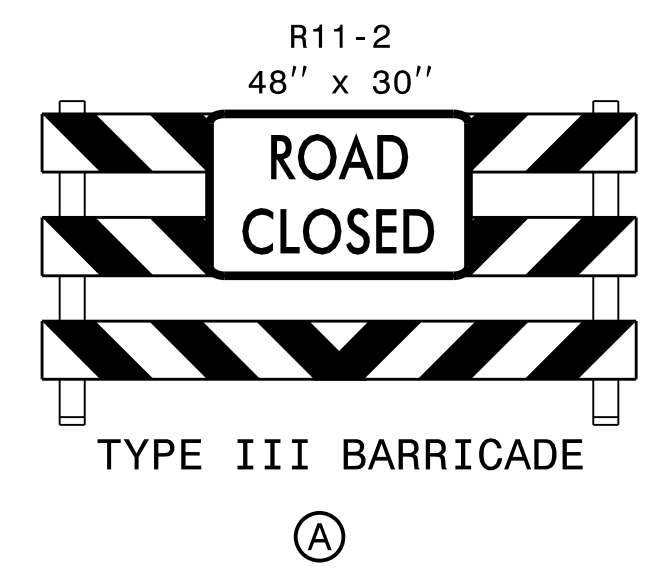
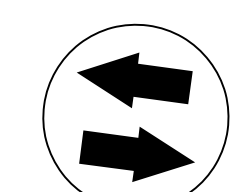
MATCHLINE -L- STA. 225 + 50, SEE TMP-4.17

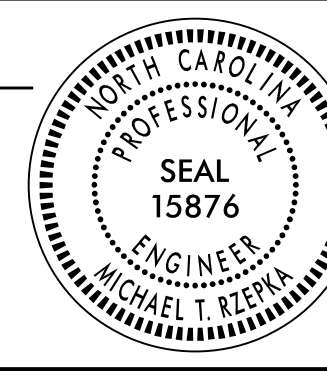

APPROVED: <u>Michael T. Rzepka</u> DATE: <u>7/12/2022</u> SEAL 		PHASE 1 - STEP 1
DOCUMENT NOT CONSIDERED FINAL UNLESS ALL SIGNATURES COMPLETED		

PHASE 1 STEP 1B
INSTALL 72" CROSS PIPE USING ROAD CLOSURE WITH OFFSITE DETOUR AND WEEKEND ICT.
SEE SHEET TMP-2C FOR DETOUR.

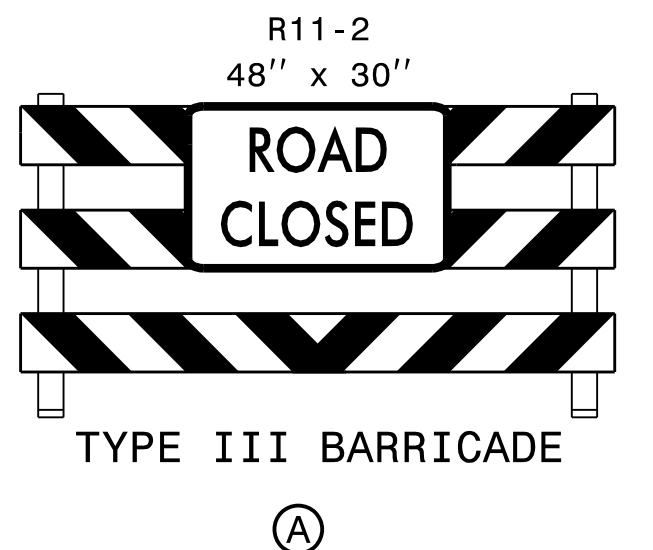
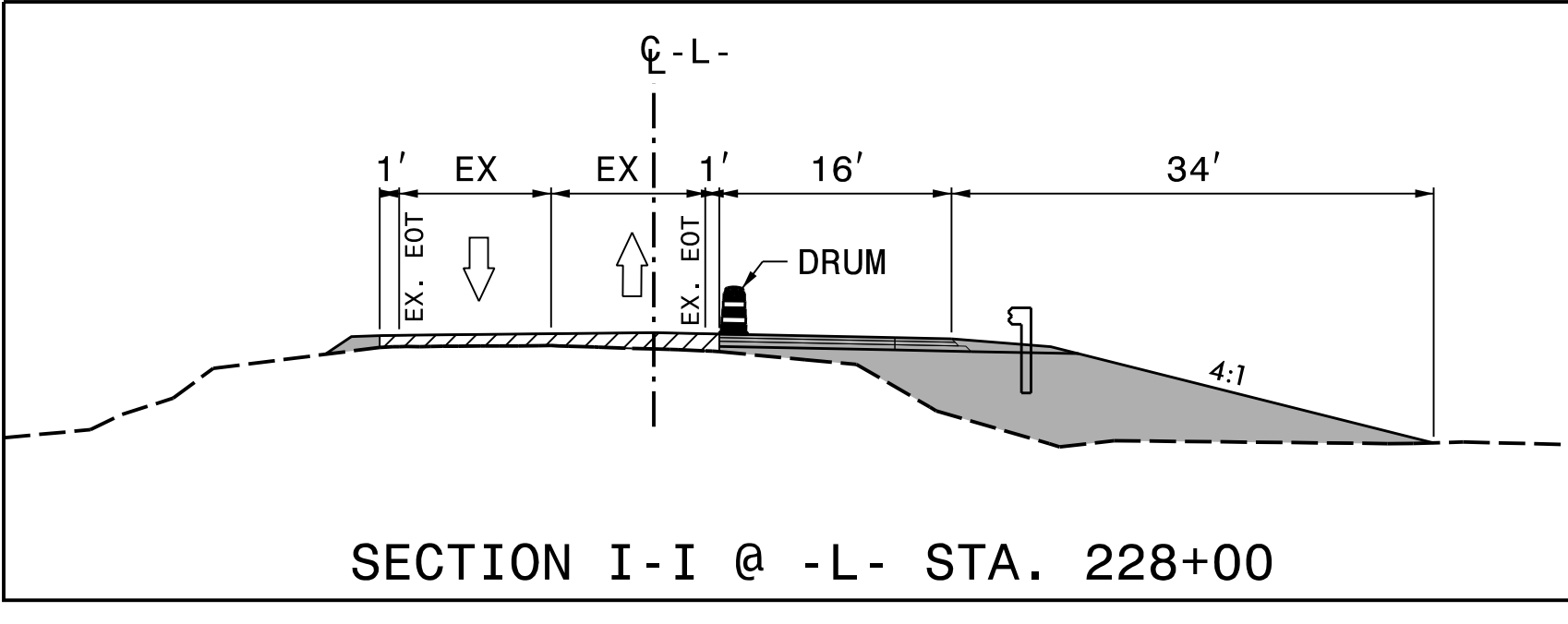
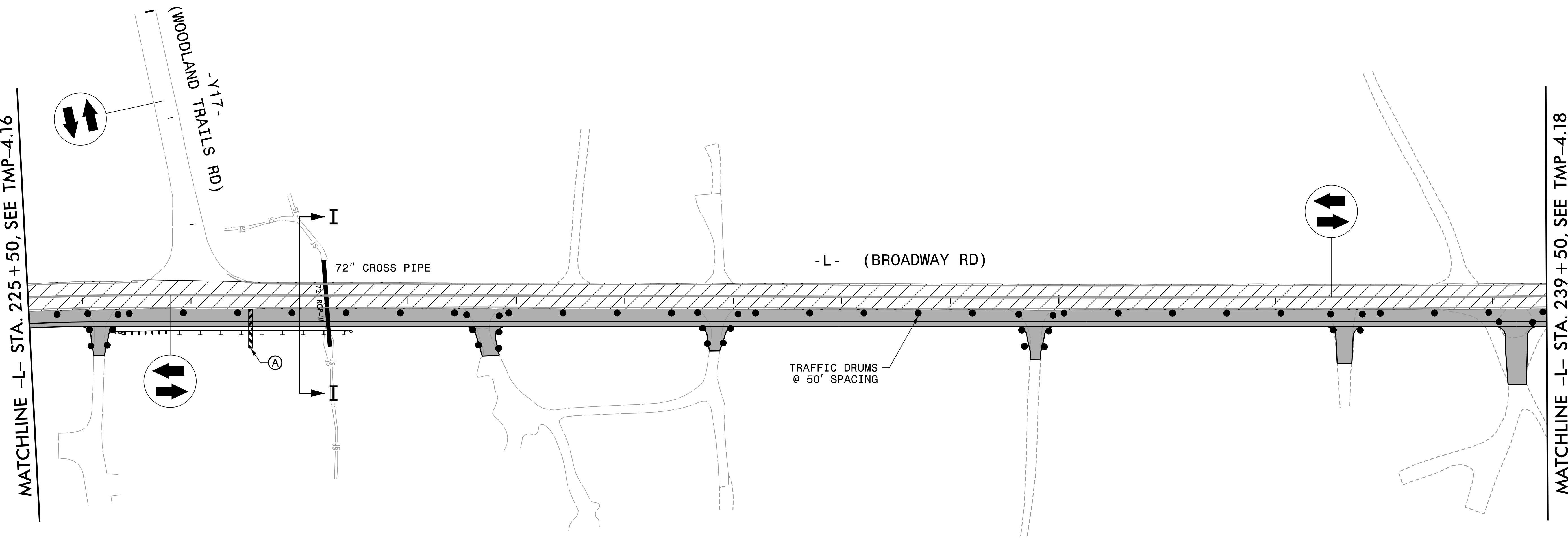

APPROVED: *Michael T. Rzepka*

DATE: 7/12/2022

SEAL

**DOCUMENT NOT CONSIDERED FINAL
UNLESS ALL SIGNATURES COMPLETED**

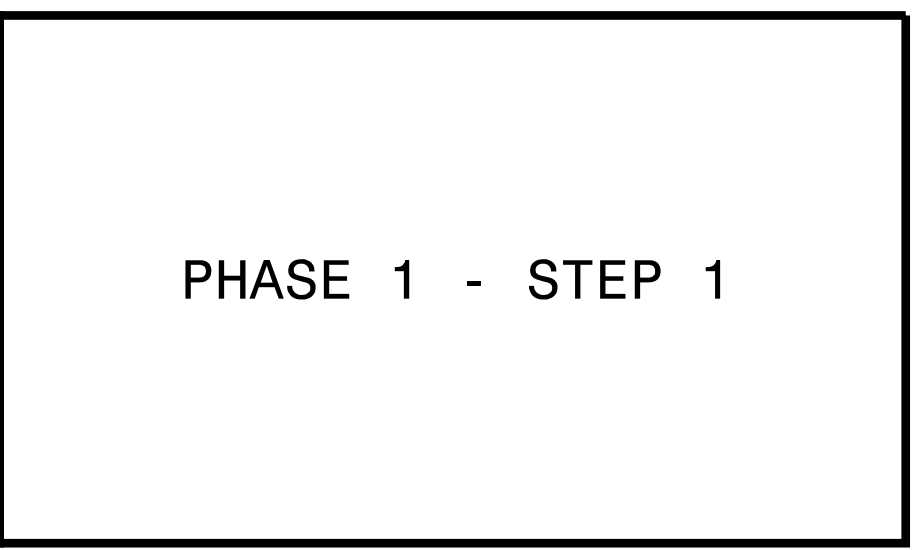



PLOT DRIVER: NCDOT_pdf_color_eng_50.pit
PENTABLE: NCDOT_tcp.tbl
USER: CHARNDEN
DATE: 5/31/2022
TIME: 5:11:43 PM
FILE: p:\p\pdr\uses\01\HDR_US_East_01\Documents\3322\10002133\10279033\6_0_CAD_BIM\6.2_WIP\TrafficControl\TCP\R3830_TC_TMP-04.17.dgn

REVISIONS

PLOT DRIVER: NCDOT_pdf_color_eng_50.plt
 USER: CHARNDEN
 DATE: 5/4/2022
 TIME: 10:47:44 AM
 FILE: p:\pw\hdf\uses\01\hdf-us-east-01\documents\3322\10002133\10279033\6_0_CAD_BITMAP\6.2\IP\TrafficControl\TCP\3830_TC_TMP-04.18.dgn

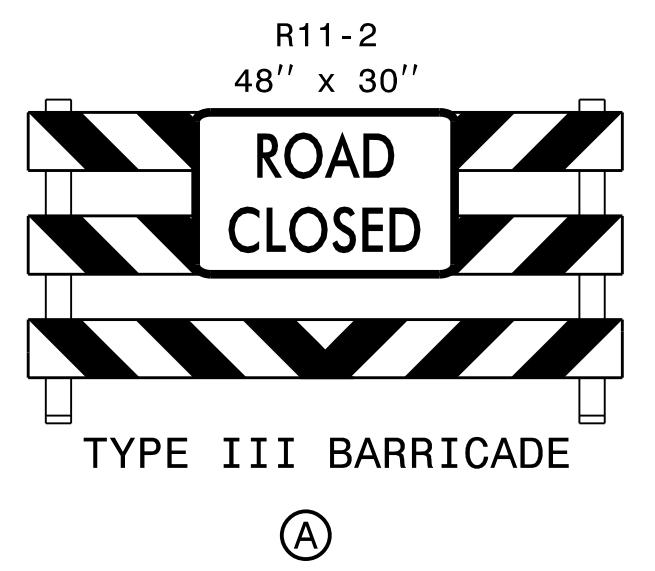
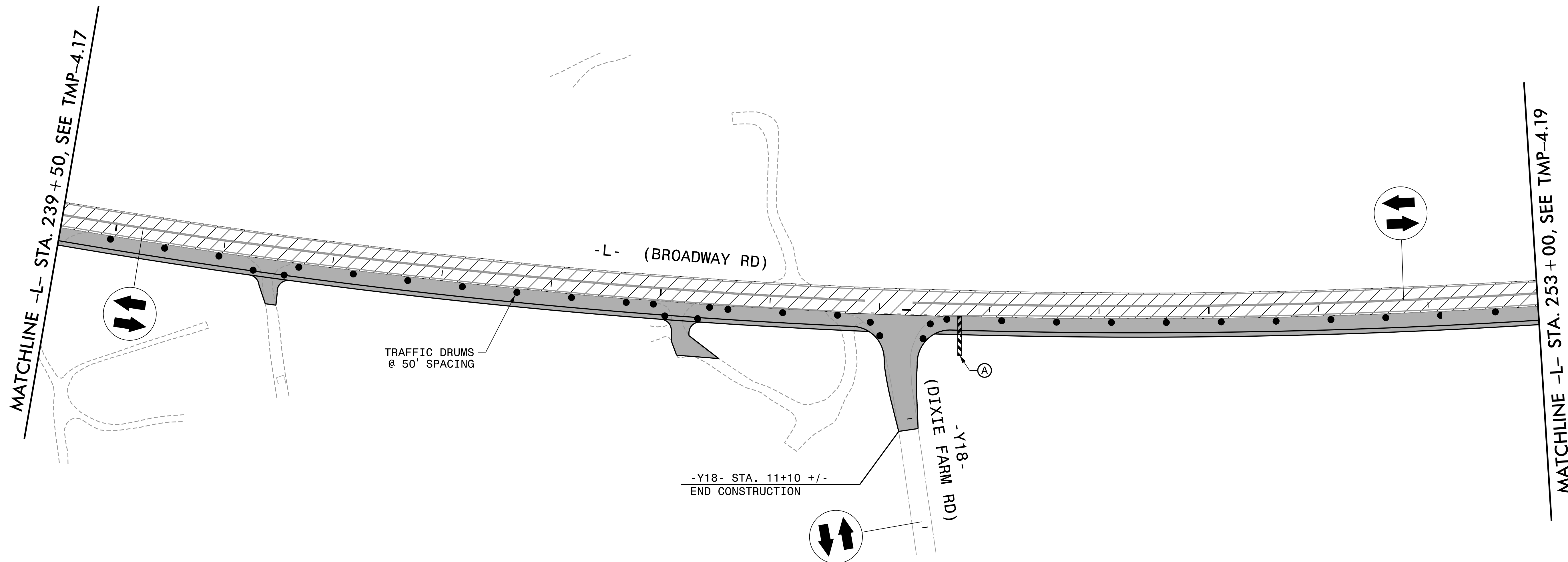
REVISIONS

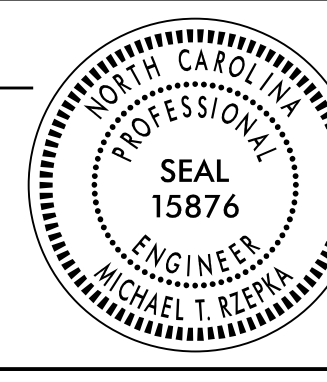

APPROVED: <i>Michael T. Rzepka</i> DATE: 7/12/2022 SEAL 		PHASE 1 - STEP 1
DOCUMENT NOT CONSIDERED FINAL UNLESS ALL SIGNATURES COMPLETED		

PLOT DRIVER: NCDOT_pdf_color_eng_50.pit
USER: CHARNDEN
FILE: p:\pwhdr\users\01\HDR_US_East_01\Documents\3322\10002133\10279033\6_0_CAD_BIM\6.2_WIP\TrafficControl\TCP\3830_TC_TMP-04.19.dgn

PENTABLE: NCDOT_tcp.tbl
DATE: 5/4/2022
TIME: 10:47:53 AM

REVISIONS

PROJ. REFERENCE NO.	SHEET NO.
R-3830	TMP-4.19
HDR Engineering, Inc. of the Carolinas 555 Fayetteville St., Suite 900 Raleigh, N.C. 27601 N.C.B.E.L.S. License Number: F-0116	

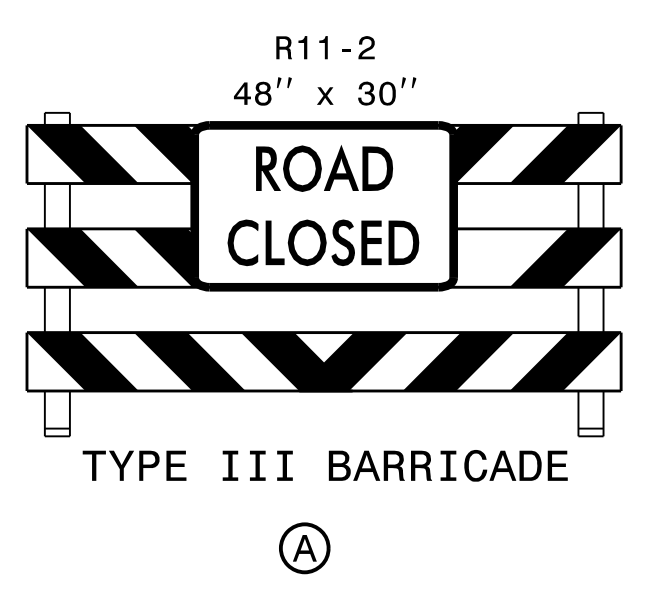
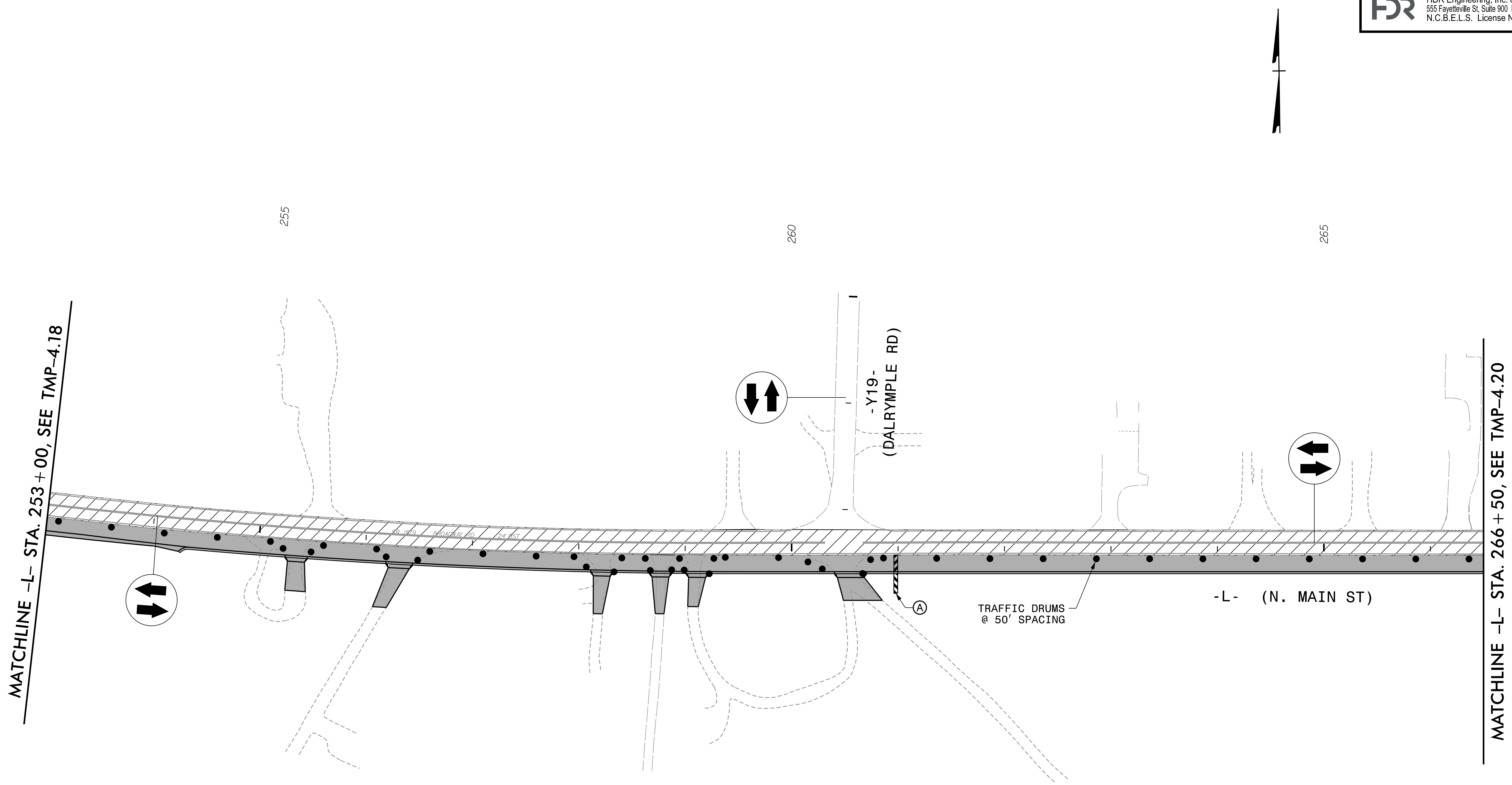

APPROVED: <i>Michael T. Rzepka</i>			PHASE 1 - STEP 1
DATE: 7/12/2022			
<p>DOCUMENT NOT CONSIDERED FINAL UNLESS ALL SIGNATURES COMPLETED</p>			

MATCHLINE -L- STA. 266 + 50, SEE TMP-4.19

MATCHLINE -L- STA. 280 + 50, SEE TMP-4.21

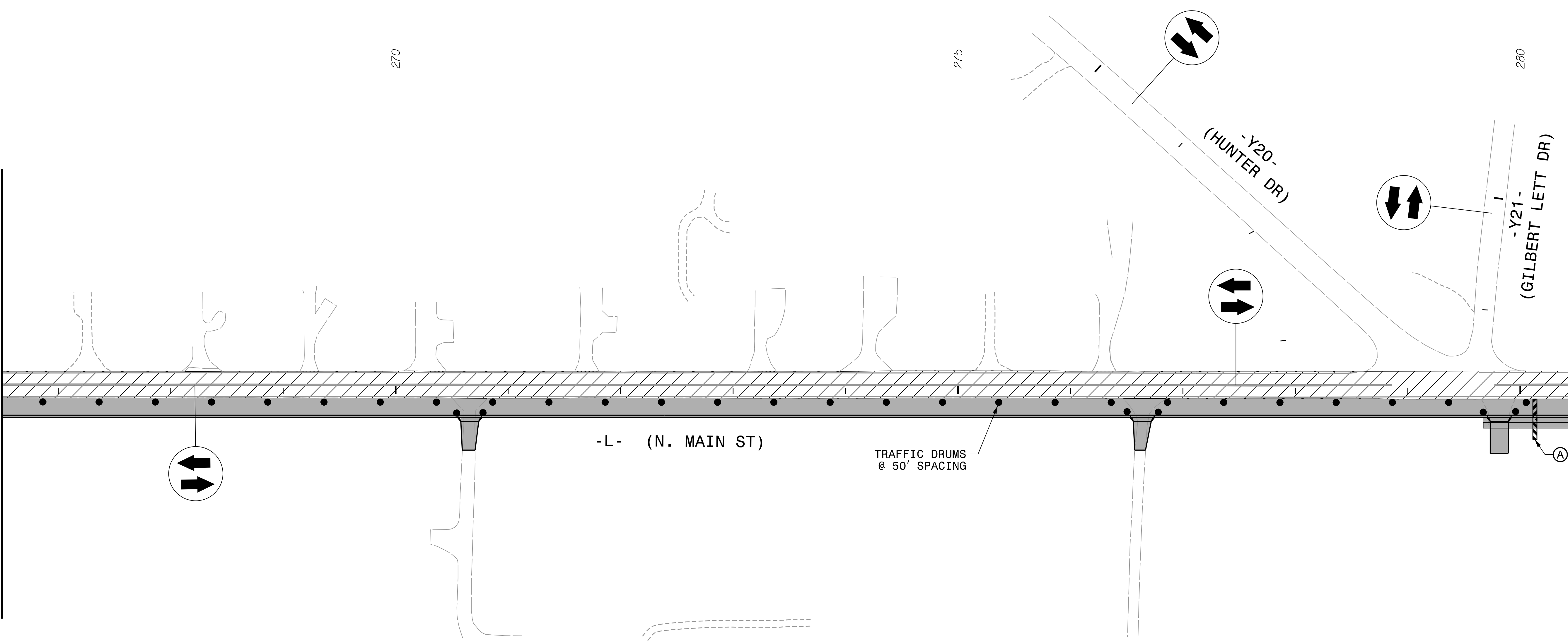

REVISIONS

PLOT DRIVER: NCDOT_pdf_color_eng_50.pit
 USER: CHARNDEN
 DATE: 5/4/2022
 TIME: 10:48:01 AM
 FILE: p:\p\hndr\usesd01\HDR_US_East_01\Documents\3322\10002133\10279033\6_0_CAD_BITMAP\6.2_WIP\TrafficControl\TCP\R3830_TC_TMP-04.20.dgn

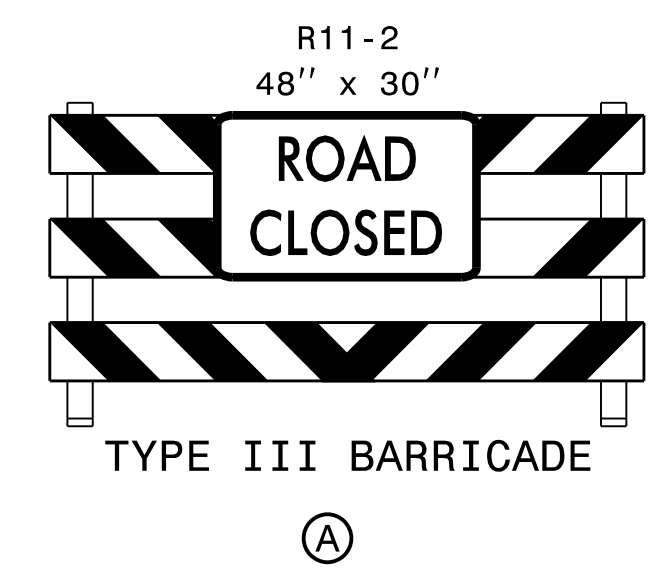
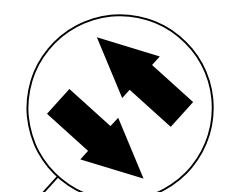
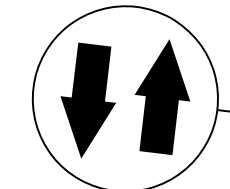
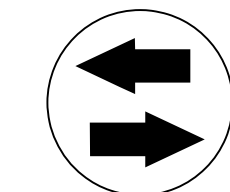
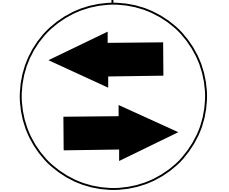

TRAFFIC DRUMS
@ 50' SPACING

APPROVED: *Michael T. Rzepka*

DATE: 7/12/2022

SEAL

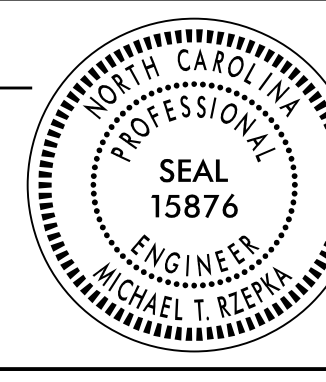

**DOCUMENT NOT CONSIDERED FINAL
UNLESS ALL SIGNATURES COMPLETED**

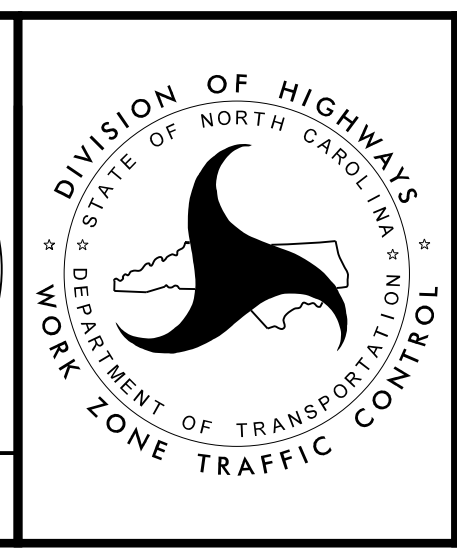

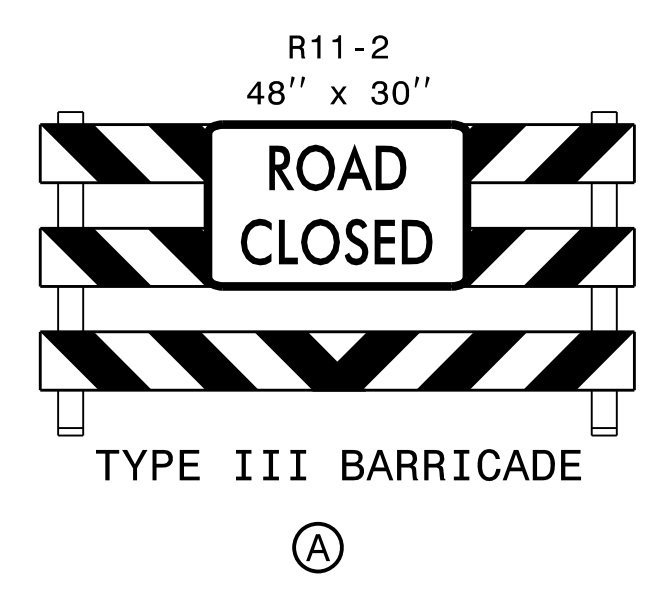
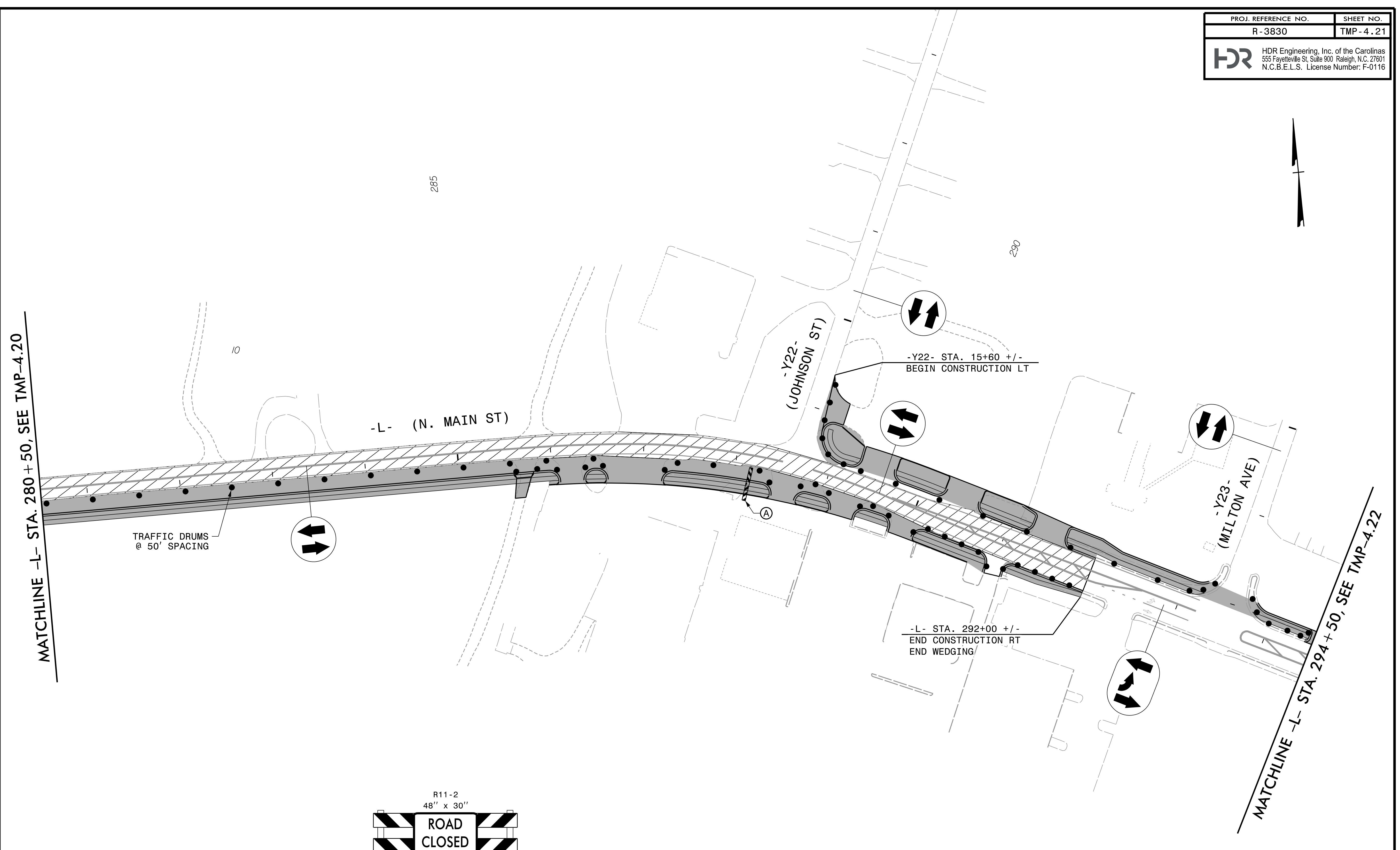
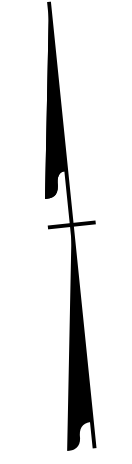

PHASE 1 - STEP 1

PROJ. REFERENCE NO. R-3830	SHEET NO. TMP-4.21
 HDR Engineering, Inc. of the Carolinas 555 Fayetteville St., Suite 900 Raleigh, N.C. 27601 N.C.B.E.L.S. License Number: F-0116	

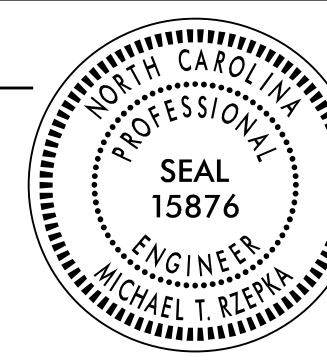

REVISIONS

PLOT DRIVER: NCDOT_pdf_color_eng_50.pit PENTABLE: NCDOT_tcp.tbl
 USER: CHARNDEN DATE: 5/4/2022 TIME: 10:48:11 AM
 FILE: p:\p\h\p\uses\04\HDR_US_East_01\Documents\3322\10002133\10279033\6_0_CAD\BIM\6.2\IP\Traffic\TrafficControl\TCP\R3830_TC_TMP-04.21.dgn

APPROVED: <i>Michael T. Rzepka</i> DATE: 7/12/2022 SEAL			PHASE 1 - STEP 1
DOCUMENT NOT CONSIDERED FINAL UNLESS ALL SIGNATURES COMPLETED			

PROJ. REFERENCE NO.	SHEET NO.
R - 3830	TMP - 4.22

HDR HDR Engineering, Inc. of the Carolinas
 555 Fayetteville St, Suite 900 Raleigh, N.C. 27601
 N.C.B.E.L.S. License Number: F-0116

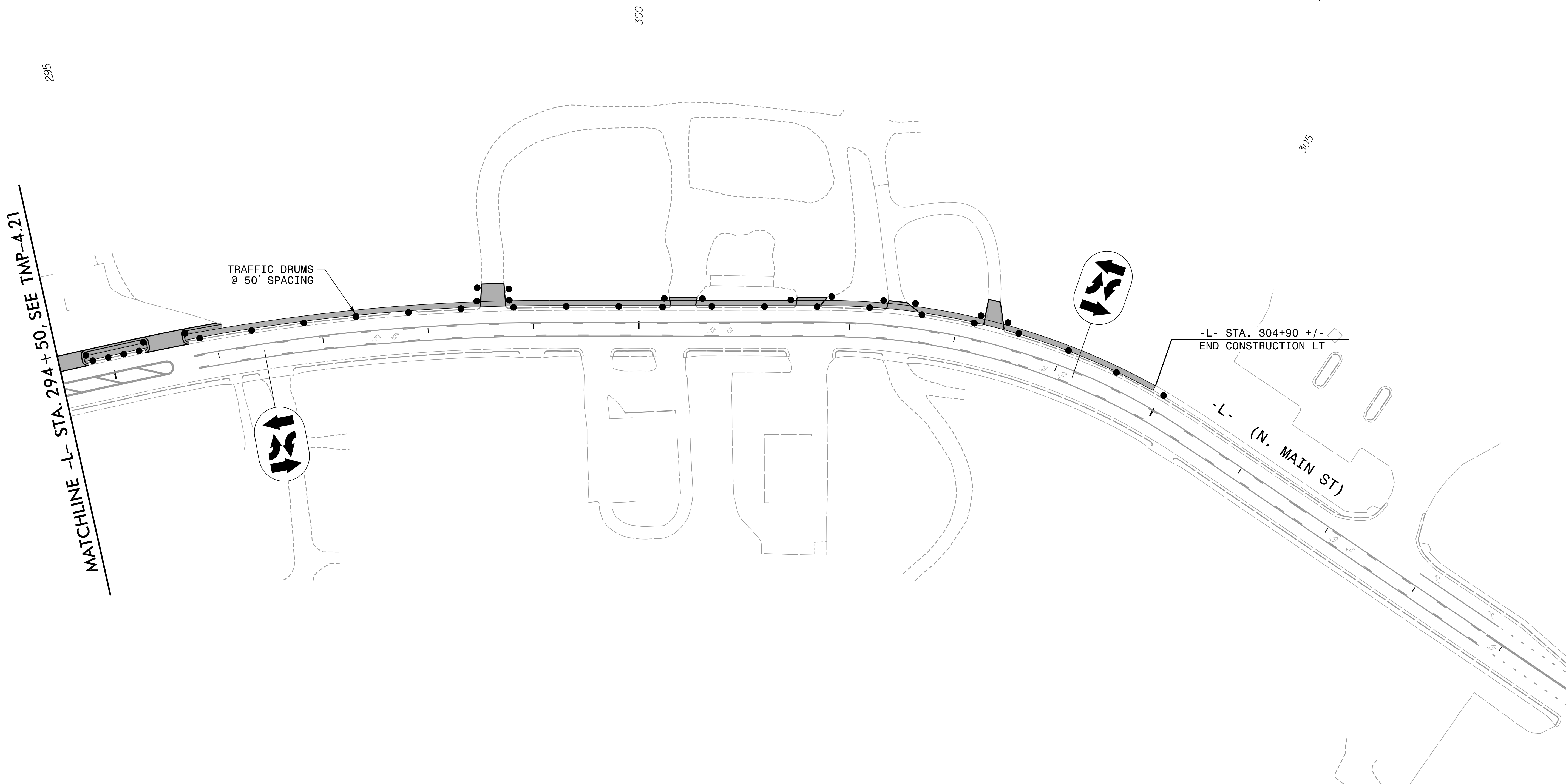

REVISIONS

PLOT DRIVER: NCDOT_pdf_color_eng_50.plt PENTABLE: NCDOT_tcp.tbl
 USER: CHARNDEN DATE: 5/4/2022 TIME: 10:48:21 AM
 FILE: p:\pw\hdr\users\01\hdr_us_east_01\Documents\3322\10002133\10279033\6_0_CAD.BIM\6.2.WIP\Traffic\TrafficControl\TCP\R3830_TC_TMP-04.22.dgn

APPROVED: <i>Michael T. Ryepka</i>			PHASE 1 - STEP 1
DATE: 7/12/2022			
<p>SEAL</p>		<p>DOCUMENT NOT CONSIDERED FINAL UNLESS ALL SIGNATURES COMPLETED</p>	

PROJ. REFERENCE NO.	SHEET NO.
R - 3830	TMP - 4.23
 HDR Engineering, Inc. of the Carolinas 555 Fayetteville St, Suite 900 Raleigh, N.C. 27601 N.C.B.E.L.S. License Number: F-0116	

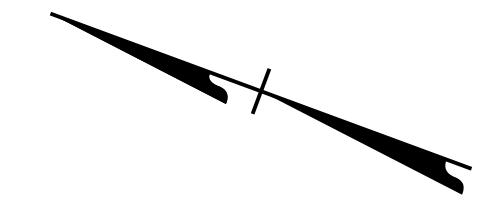

MATCHLINE -Y5- STA. 13 +50, SEE TMP-4.03

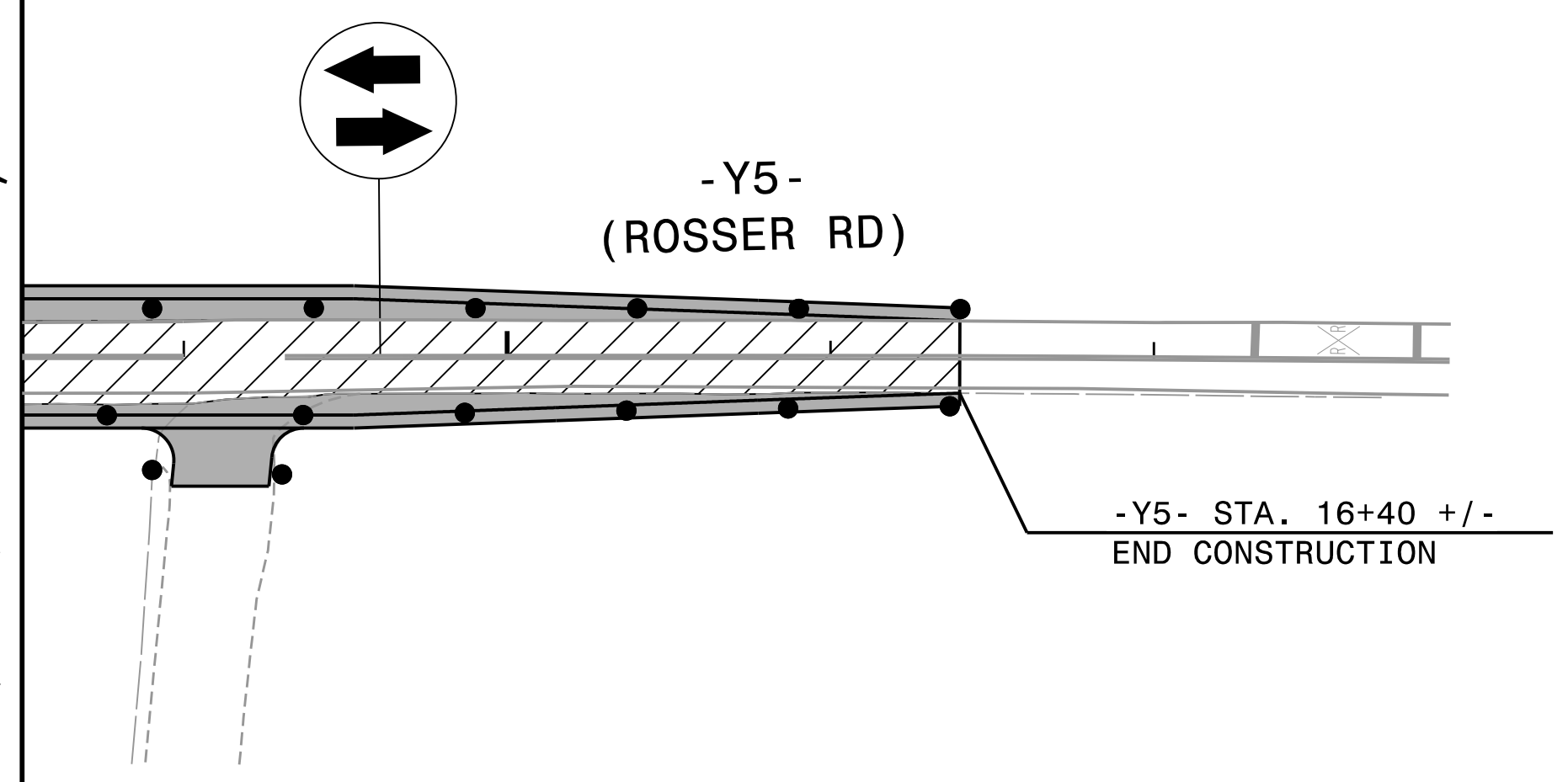

REVISIONS

PLOT DRIVER: NCDOT_pdf_color_eng_50.plt
 USER: CHARNDEN
 FILE: p:\p\hdmr\uses01\hdr\US_East_01\Documents\3322\10002133\10279033\6_0_CAD_BITMAP\6.2_WIP\TrafficControl\TCP\3830_TC_TMP-04.23.dgn

PENTABLE: NCDOT_tcp.tbl
 DATE: 5/4/2022
 TIME: 10:48:29 AM

APPROVED: *Michael T. Rzepka*

DATE: 7/12/2022

SEAL

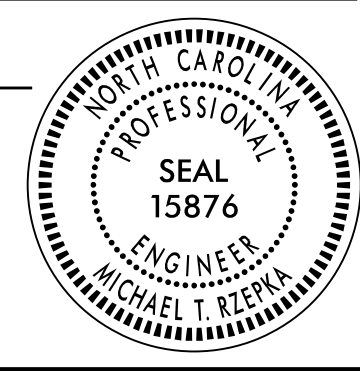

**DOCUMENT NOT CONSIDERED FINAL
UNLESS ALL SIGNATURES COMPLETED**

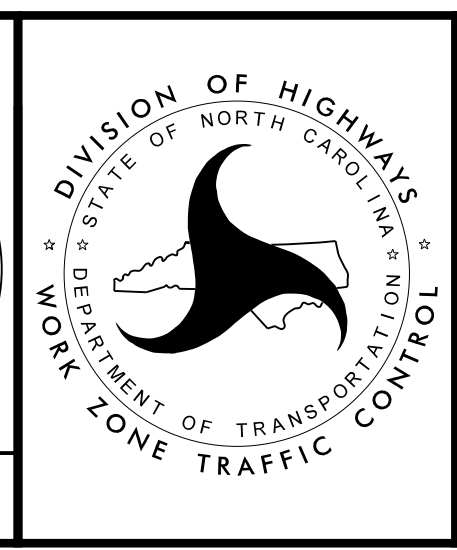

PHASE 1 - STEP 1

PROJ. REFERENCE NO.	SHEET NO.
R - 3830	TMP - 4.24
 HDR Engineering, Inc. of the Carolinas 555 Fayetteville St, Suite 900 Raleigh, N.C. 27601 N.C.B.E.L.S. License Number: F-0116	

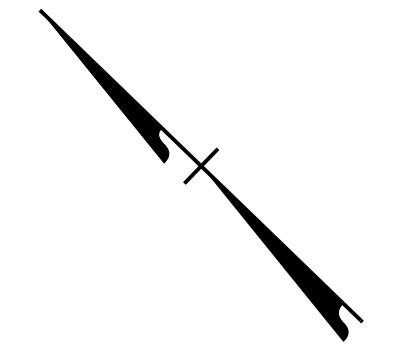

MATCHLINE -Y13- STA. 12 + 50, SEE TMP-4.09

-Y13-
(COX MILL RD)

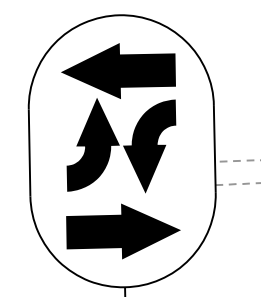

-Y13- STA. 16+25 +/-
END CONSTRUCTION
END WEDGING

REVISIONS

PLOT DRIVER: NCDOT_pdf_color_eng_50.plt PENTABLE: NCDOT_tcp.tbl
 USER: CHARNDEN DATE: 5/4/2022 TIME: 10:48:37 AM
 FILE: p:\p\h\p\users\01\h\h\US_East_01\Documents\3322\10002133\10279033\6_0_CAD.BIM\6.2.WIP\Traffic\TrafficControl\TCP\R3830_TC_TMP-04.24.dgn

APPROVED: *Michael T. Rzepka*

DATE: 7/12/2022

SEAL

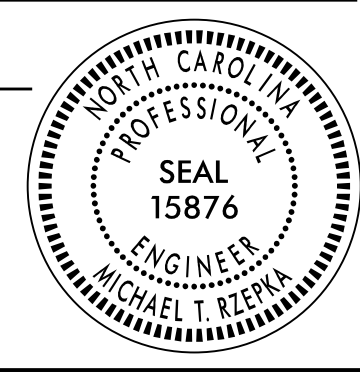

**DOCUMENT NOT CONSIDERED FINAL
UNLESS ALL SIGNATURES COMPLETED**

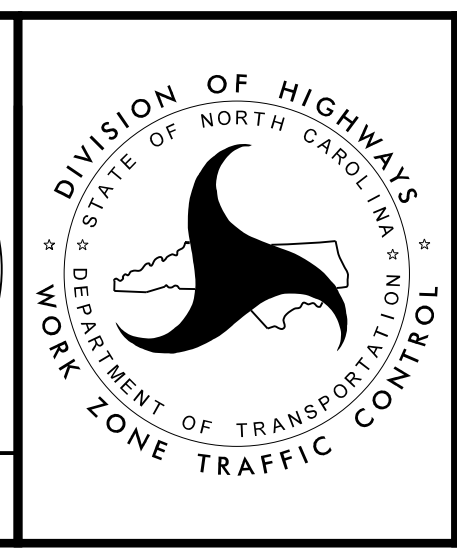

PHASE 1 - STEP 1



CLOSE EASTBOUND RIGHT TURN LANE AND WESTBOUND LEFT TURN LANE ALONG -L- APPROACHING -Y13- WHEN -Y13- IS CLOSED FOR CONSTRUCTION. COVER WESTBOUND LEFT TURN SIGNAL HEAD. RESTORE TRAFFIC ALONG -L- WHEN -Y13- CONSTRUCTION IS COMPLETED AND -Y13- IS OPEN TO TRAFFIC.

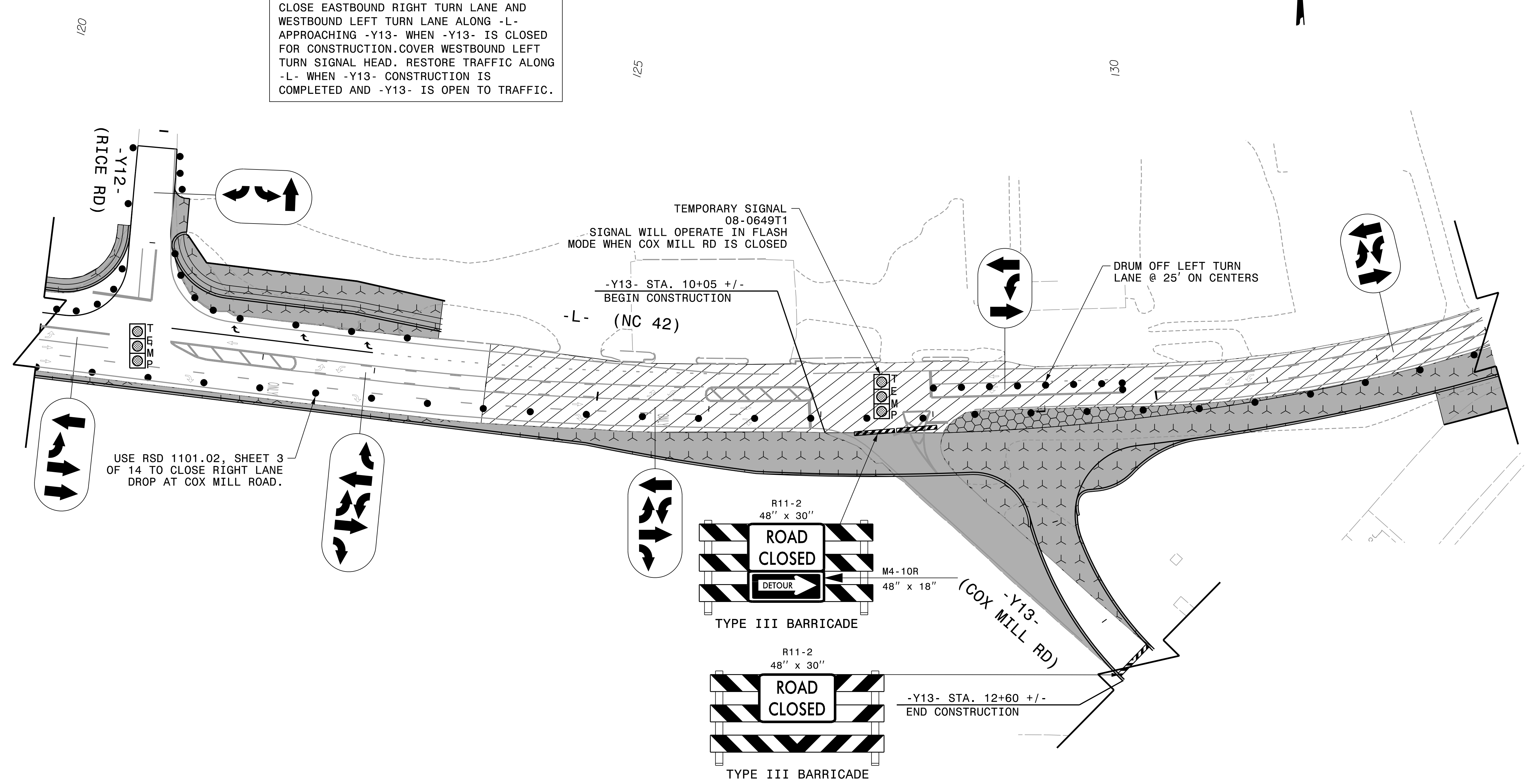

REVISIONS

PLOT DRIVER: NCDOT_pdf_color_eng_50.plt
 USER: CHARNDEN
 DATE: 5/4/2022
 PENTABLE: NCDOT_tcp.tbl
 TIME: 10:48:45 AM
 FILE: p:\pwhdr\users\charnden\Documents\3322\10002133\10279033\6_0_CAD_BITMAP\6.2_WIP\TrafficControl\TCP\R3830_TC_TMP-04.25.dgn

APPROVED: *Michael T. Rzepka*
 DATE: 7/12/2022
 SEAL



PHASE 1 - STEP 1A

DOCUMENT NOT CONSIDERED FINAL UNLESS ALL SIGNATURES COMPLETED

PROJ. REFERENCE NO.	SHEET NO.
R - 3830	TMP - 4.26

HDR HDR Engineering, Inc. of the Carolinas
555 Fayetteville St, Suite 900 Raleigh, N.C. 27601
N.C.B.E.L.S. License Number: F-0116

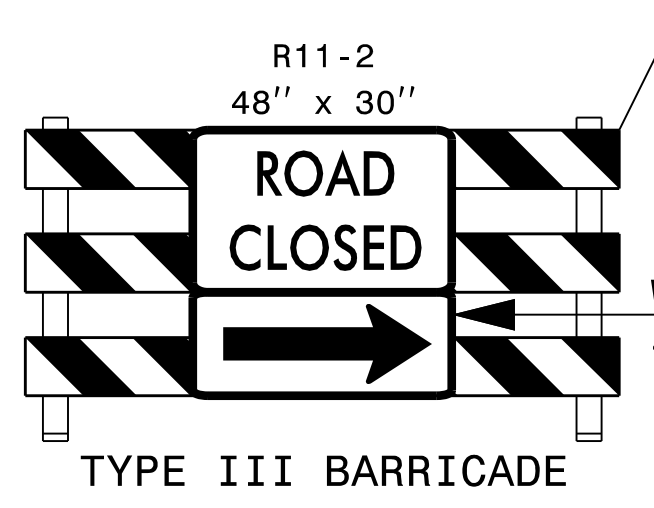
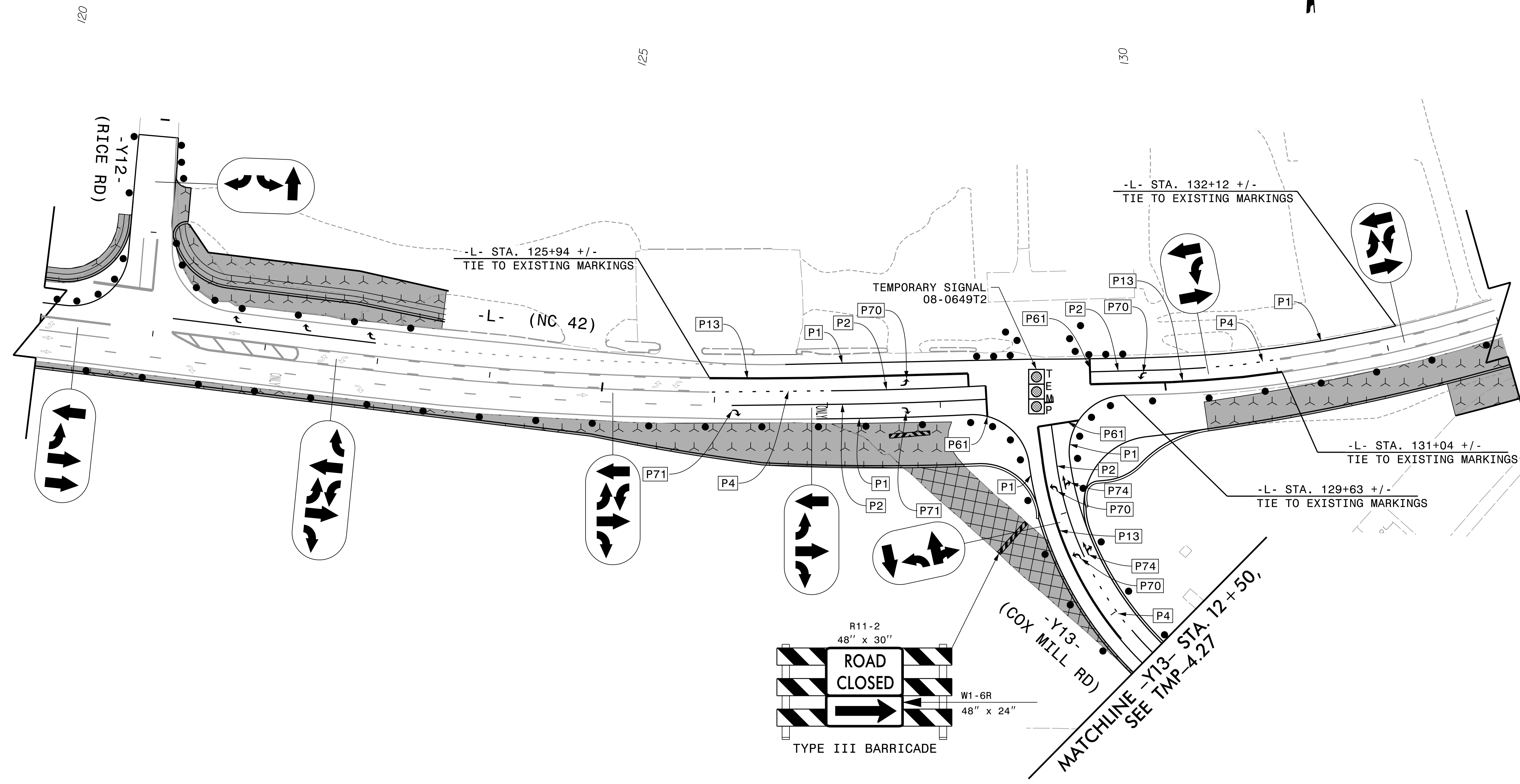

REVISIONS

PLOT DRIVER: NCDOT_pdf_color_eng_50.pit
PENTABLE: NCDOT_tcp.tbl
USER: CHARNDEN DATE: 5/4/2022 TIME: 10:48:54 AM
FILE: p:\pvhdr\users\01\Documents\3322\10002133\10279033\6.0\CAD\BITM\6.2.WIP\TrafficControl\TCP\3830_TC_TMP-04.26.dgn

APPROVED: *Michael T. Respha*

DATE: 7/12/2022

SEAL

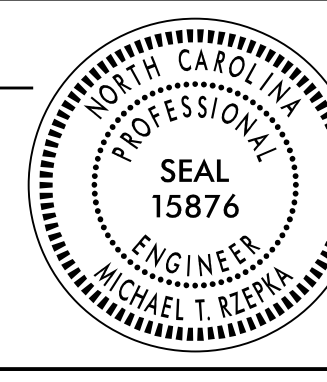

**DOCUMENT NOT CONSIDERED FINAL
UNLESS ALL SIGNATURES COMPLETED**

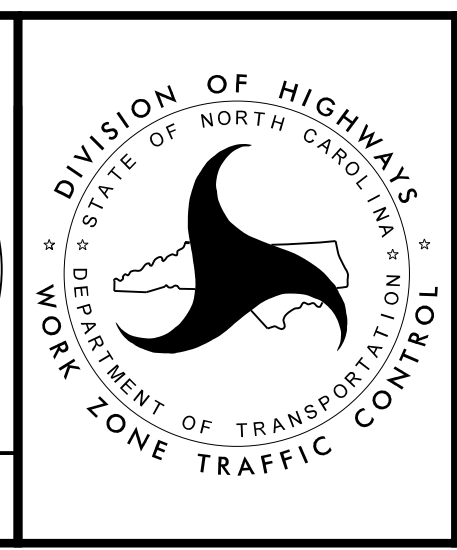

PHASE 1 - STEP 1A

PROJ. REFERENCE NO.	SHEET NO.
R - 3830	TMP - 4.27
 HDR Engineering, Inc. of the Carolinas 555 Fayetteville St, Suite 900 Raleigh, N.C. 27601 N.C.B.E.L.S. License Number: F-0116	

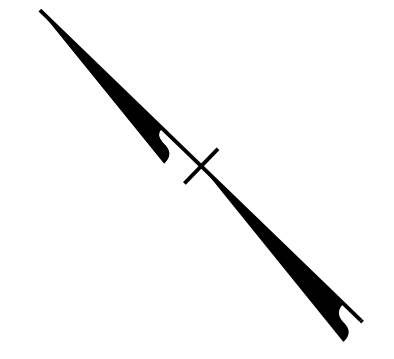

MATCHLINE -Y13- STA. 12 + 50, SEE TMP-4.26

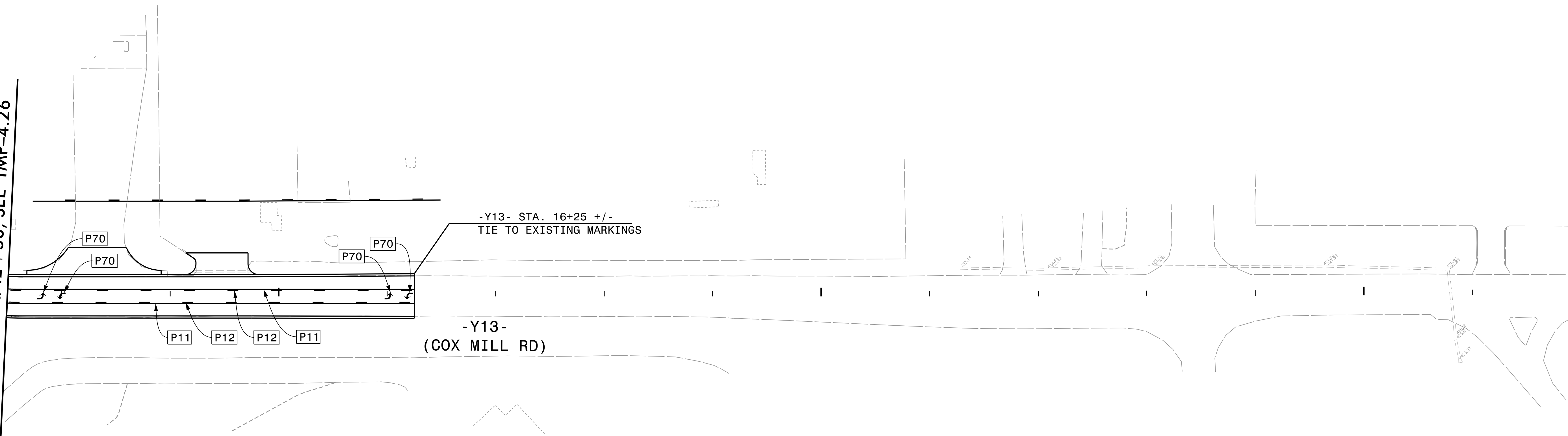

REVISIONS

PLOT DRIVER: NCDOT_pdf_color_eng_50.plt PENTABLE: NCDOT_tcp.tbl
 USER: CHARNDEN DATE: 5/4/2022 TIME: 10:49:03 AM
 FILE: p:\p\h\p\users\01\h\p\US_East_01\Documents\3322\10002133\10279033\6_0_CAD_BITMAP\6.2_WIP\TrafficControl\CP\3830_TC_TMP-04.27.dgn

APPROVED: *Michael T. Rzepka*

DATE: 7/12/2022

SEAL

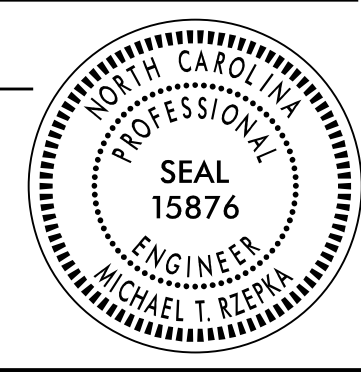

**DOCUMENT NOT CONSIDERED FINAL
UNLESS ALL SIGNATURES COMPLETED**

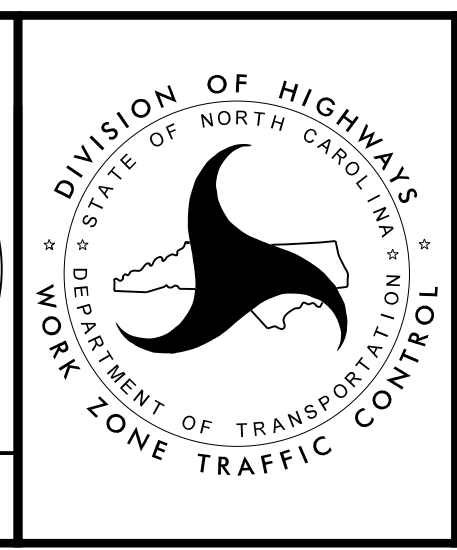

PHASE 1 - STEP 1A

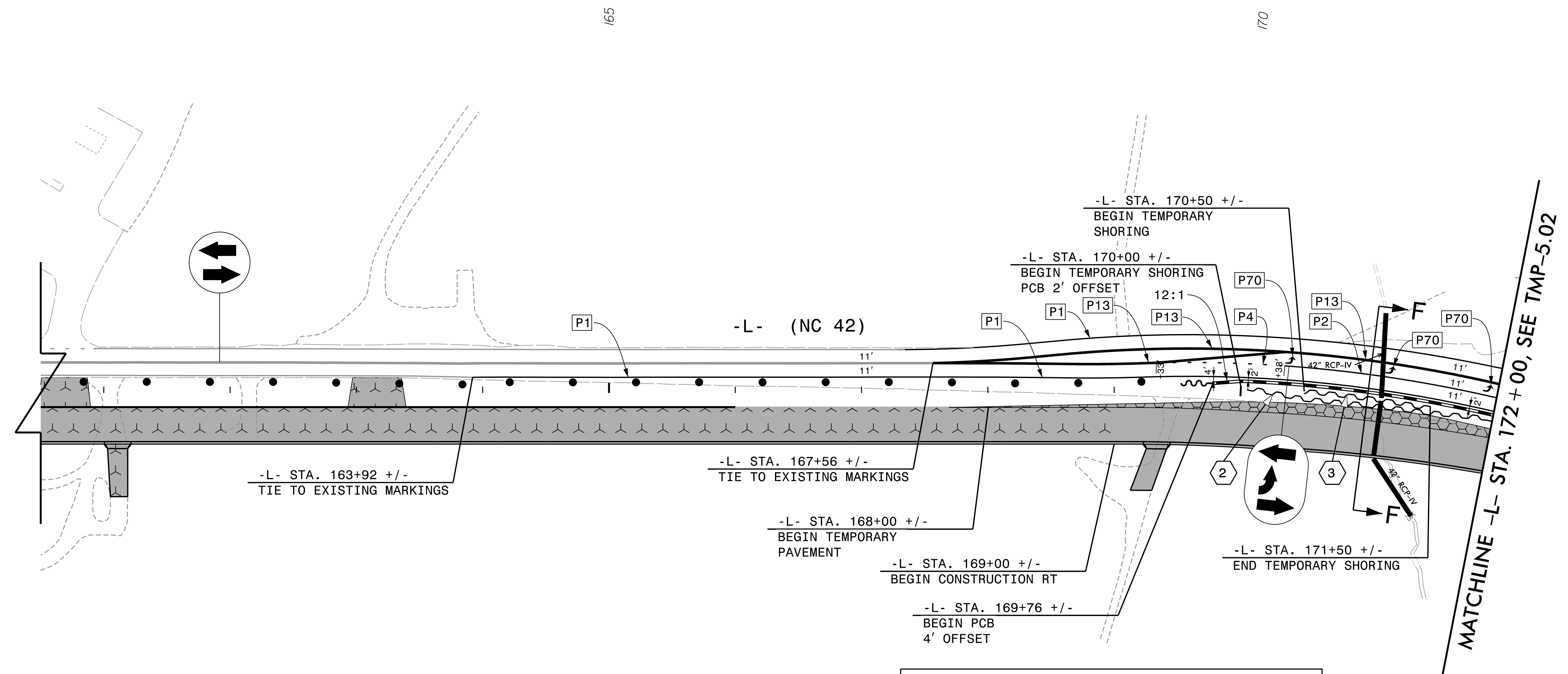
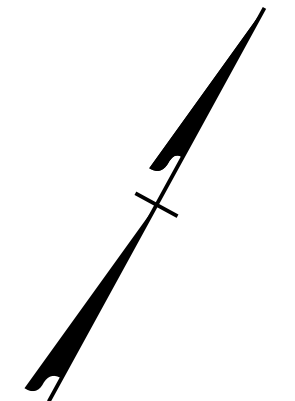

- SEE TMP-2A FOR TEMP. SHORING INFORMATION
- ② -L- STA 170+00± 7.5' LT TO STA 174+00±, 7.0' LT
QUANTITY = 1600 S.F.
 - ③ -L- STA 170+50± 7.7' LT TO STA 171+65±, 6.6' LT
QUANTITY = 690 S.F.

REVISIONS

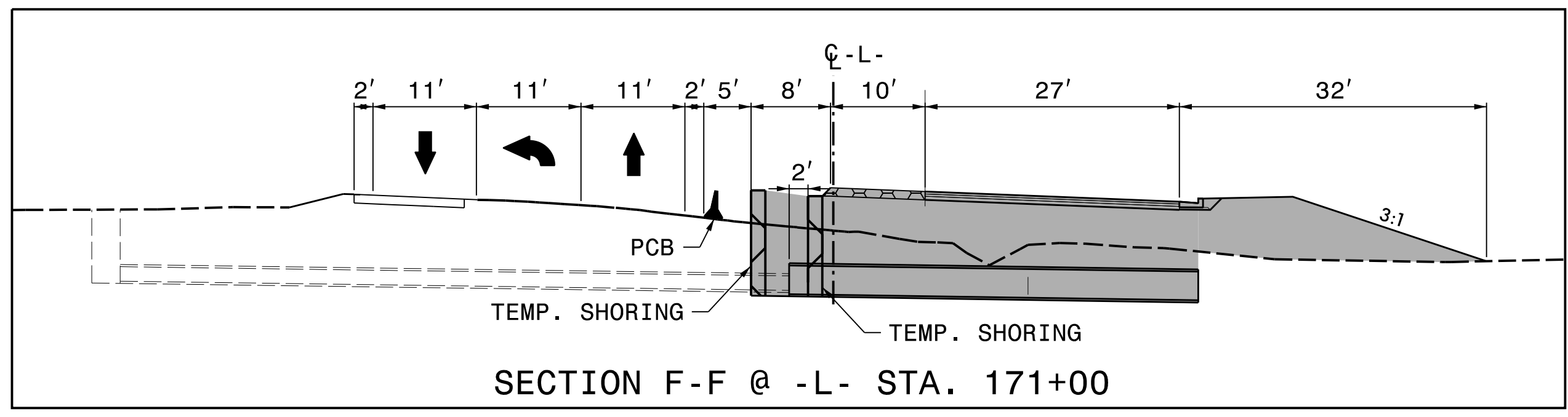

PLOT DRIVER: NCDOT_pdf_color_eng_50.pit PENTABLE: NCDOT_tcp.tbl
USER: CHARNDEN DATE: 5/4/2022 TIME: 10:49:12 AM
FILE: p:\p\h\users\charnd\us\documents\3322\10002133\10279033\6_0_CAD.BITM\6_2.WIP\TrafficControl\CP\3830_TC_TMP-05.01.dgn

APPROVED: *Michael T. Rzepka*

DATE: 7/12/2022

SEAL

PROFESSIONAL ENGINEER
MICHAEL T. RZEPKA
15876

DOCUMENT NOT CONSIDERED FINAL
UNLESS ALL SIGNATURES COMPLETED

DIVISION OF HIGHWAYS
NORTH CAROLINA
STATE OF NORTH CAROLINA
DEPARTMENT OF TRANSPORTATION
WORK ZONE TRAFFIC CONTROL

PHASE 1 - STEP 2

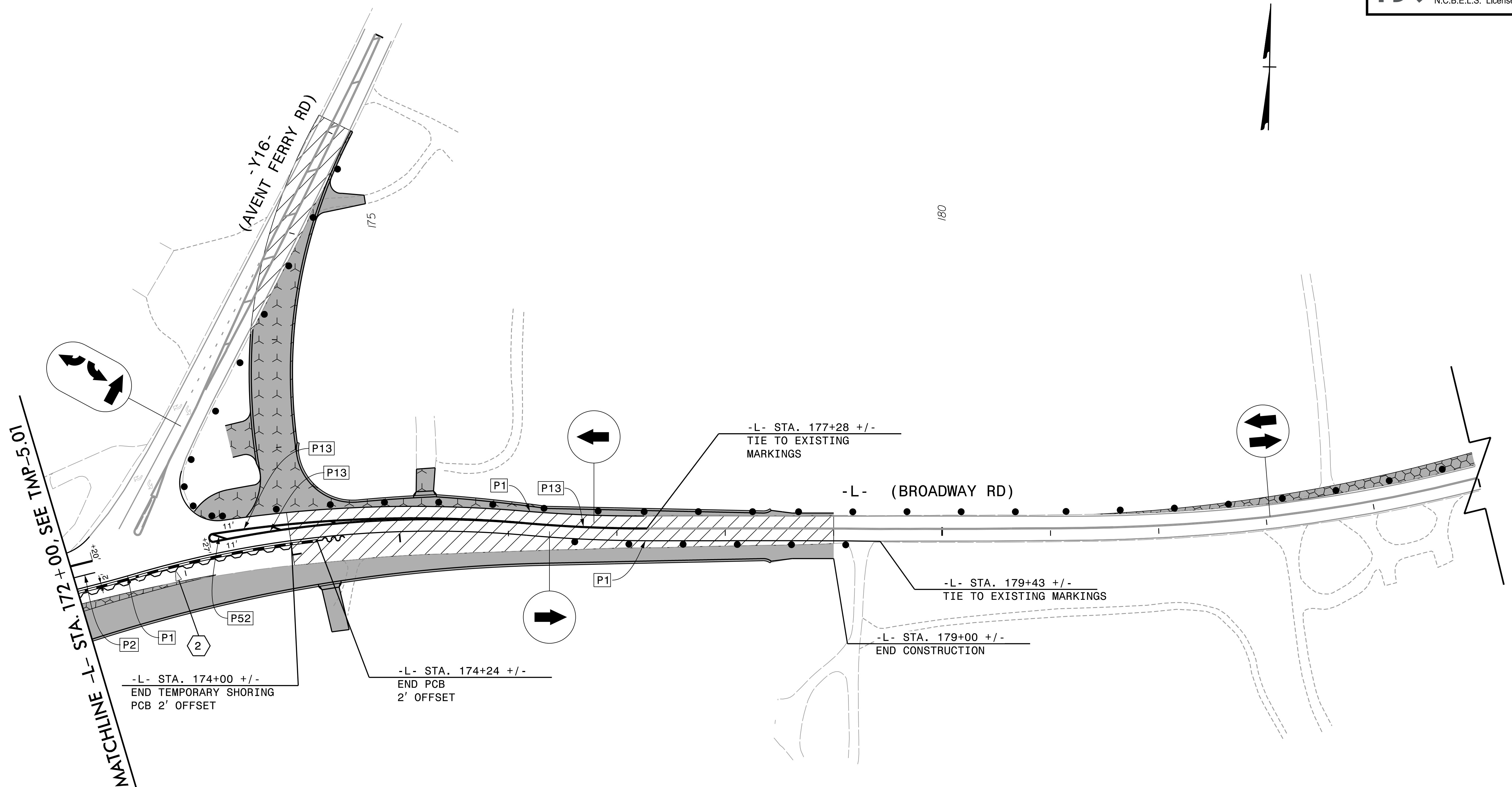

REVISIONS

SEE TMP-2A FOR TEMP. SHORING INFORMATION

② -L- STA 170+00± 7.5' LT TO STA 174+00±, 7.0' LT
 QUANTITY = 1600 S.F.

PLOT DRIVER: NCDOT_pdf_color_eng_50.plt
 USER: CHARNDEN
 FILE: p:\p\h\p\uses\01\HDR_US_East_01\Documents\3322\10002133\10279033\6_0_CAD_BIM\6.2_WIP\Traffic\TrafficControl\TCP\R3830_TC_TMP-05.02.dgn

PENTABLE: NCDOT_tcp.tbl
 DATE: 5/4/2022
 TIME: 10:49:21 AM

APPROVED: *Michael T. Rzepka*

DATE: 7/12/2022

SEAL

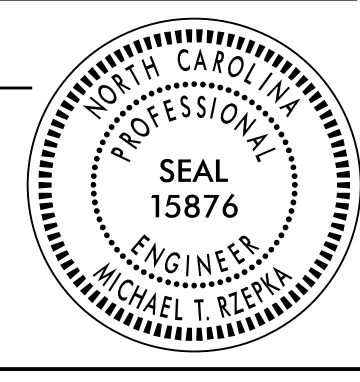

DOCUMENT NOT CONSIDERED FINAL
 UNLESS ALL SIGNATURES COMPLETED



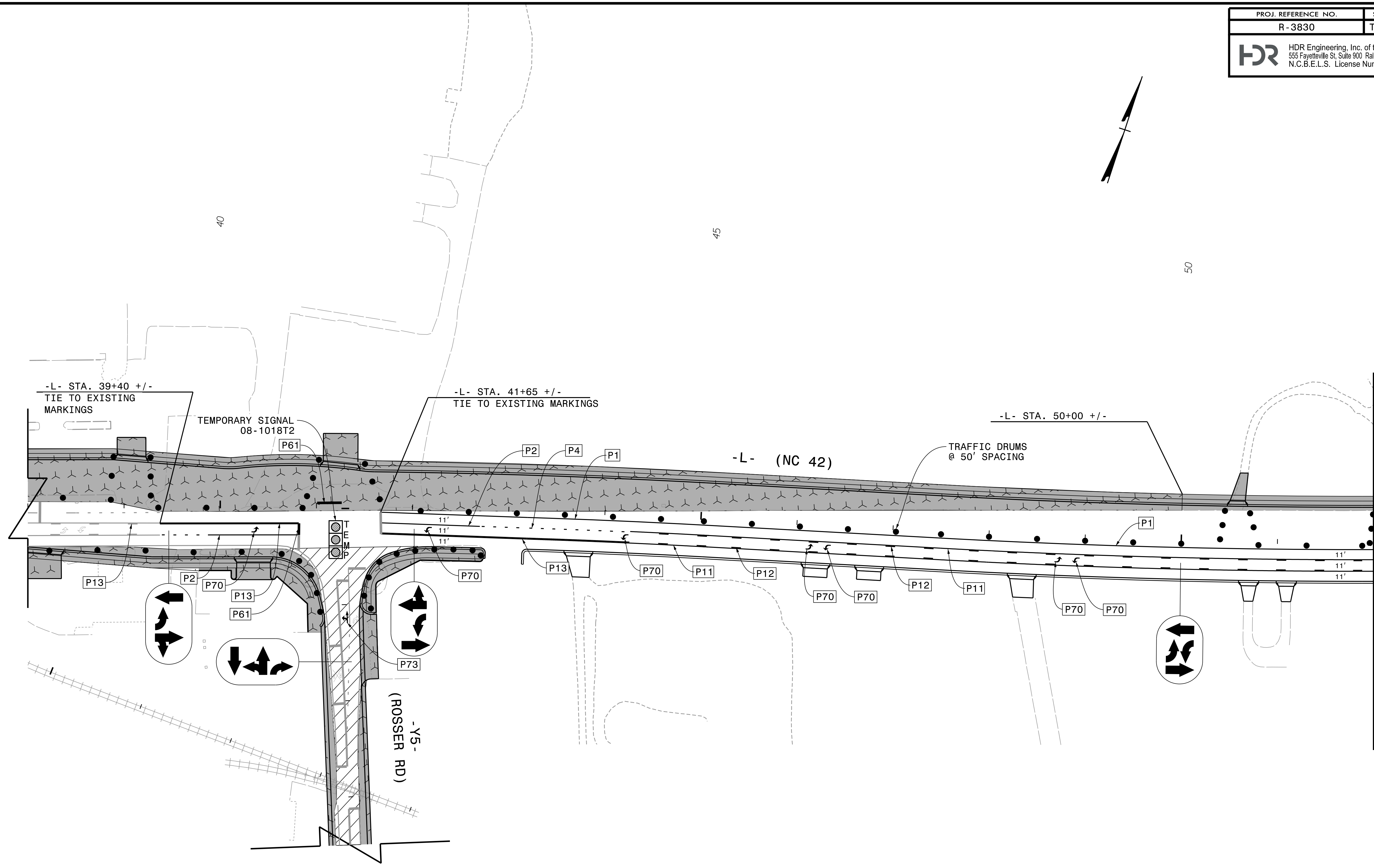
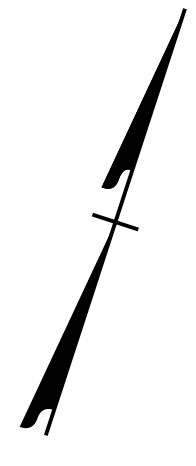

PHASE 1 - STEP 2

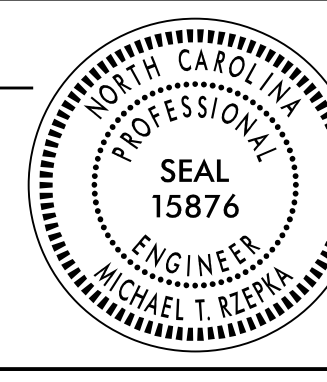

REVISIONS

PLOT DRIVER: NCDOT_color_eng_50.plt PENTABLE: NCDOT_tcp.tbl
 USER: CHARNDEN DATE: 5/4/2022 TIME: 10:49:30 AM
 FILE: p:\p\h\dr\users\01\h\dr\us_east_01\documents\3322\10002133\10279033\6.0_CAD.BIM\6.2.WIP\TrafficControl\CP\3830_TC_TMP-06.01.dgn

APPROVED: <i>Michael T. Ryepka</i>			PHASE 2 - STEP 1
DATE: 7/12/2022			
DOCUMENT NOT CONSIDERED FINAL UNLESS ALL SIGNATURES COMPLETED			

PROJ. REFERENCE NO. R - 3830	SHEET NO. TMP - 6.02
 HDR Engineering, Inc. of the Carolinas 555 Fayetteville St., Suite 900 Raleigh, N.C. 27601 N.C.B.E.L.S. License Number: F-0116	

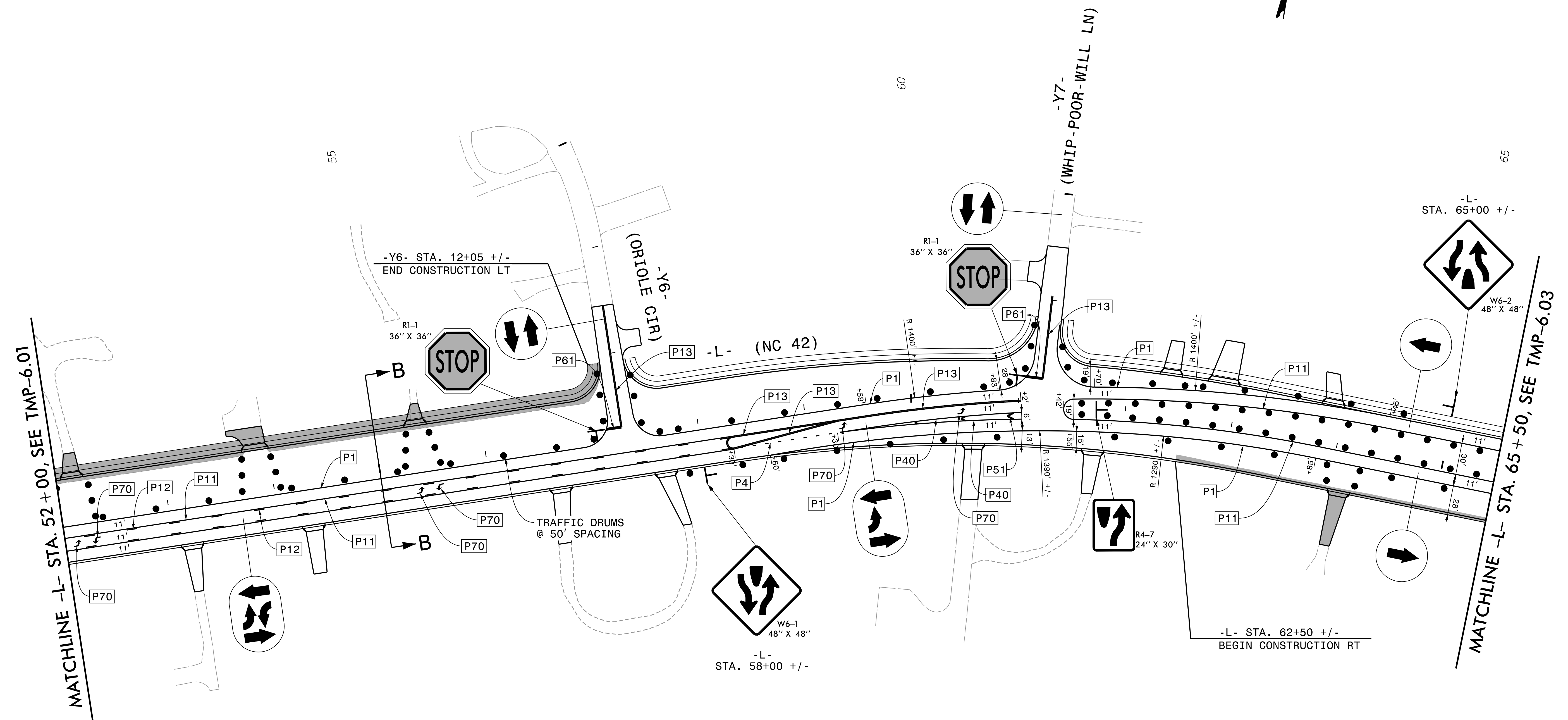
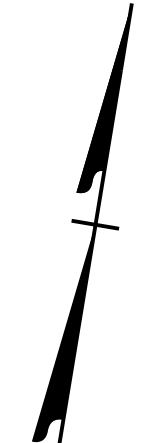

REVISIONS

PLOT DRIVER: NCDOT_pdf_color_eng_50.pit
 USER: CHARNDEN
 PENTABLE: NCDOT_tcp.tbl
 DATE: 5/4/2022
 TIME: 10:49:39 AM
 FILE: p:\p\p\h\p\users\charnden\Documents\3322\10002133\10279033\6_0_CAD_BITMAP6.2.WIP\TrafficControl\TCP\R3830_TC_TMP-06.02.dgn

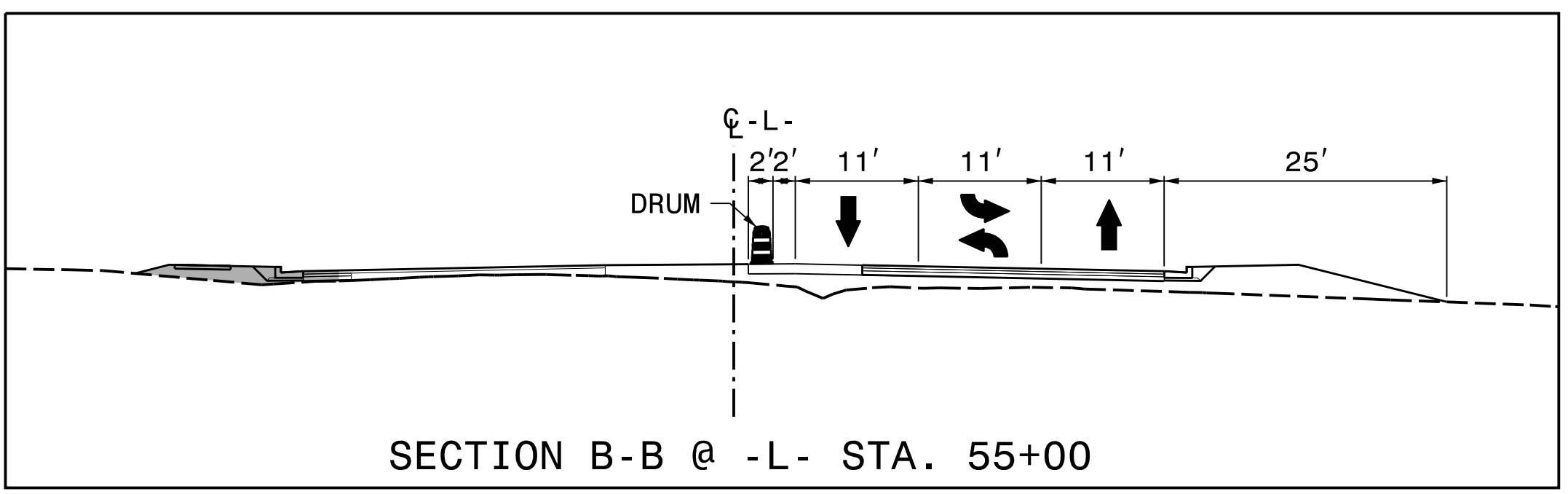

APPROVED: *Michael T. Ryepka*

DATE: 7/12/2022

SEAL

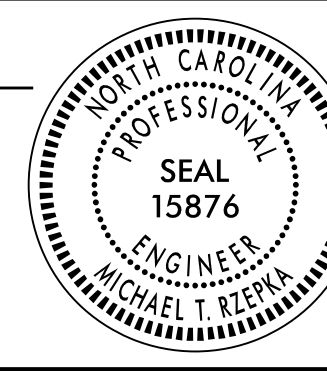

**DOCUMENT NOT CONSIDERED FINAL
UNLESS ALL SIGNATURES COMPLETED**



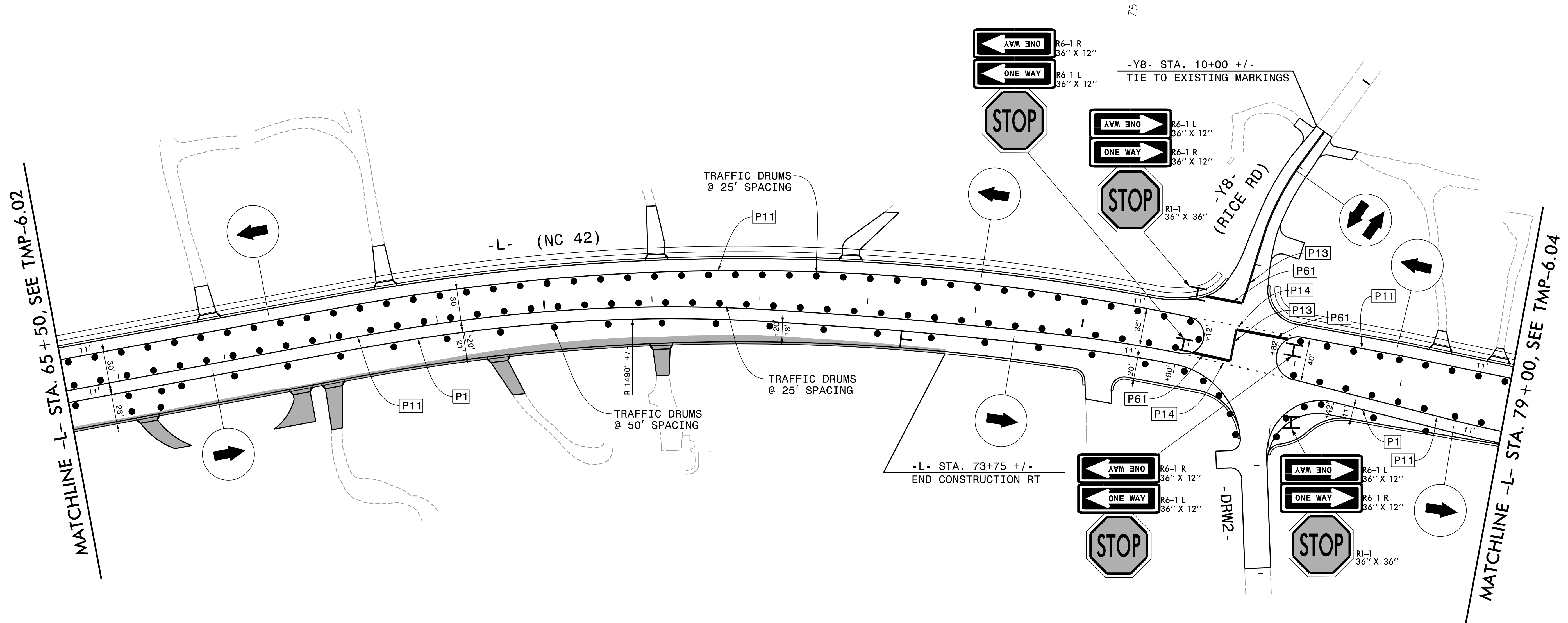

PHASE 2 - STEP 1



REVISIONS

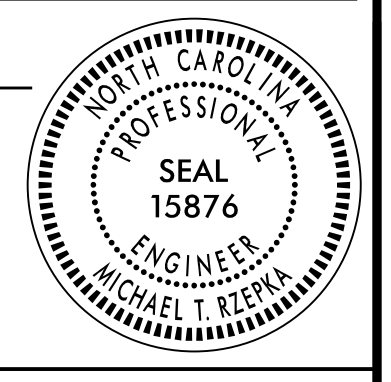

PLOT DRIVER: NCDOT_pdf_color_eng_50.plt
 USER: CHARNDEN
 DATE: 5/4/2022
 FILE: p:\pwhdr\users\charnden\US_East_01\Documents\3322\10002133\10279033\6_0_CAD_BIM\6_2_WIP\TrafficControl\CP\R3830_TC_TMP-06.03.dgn

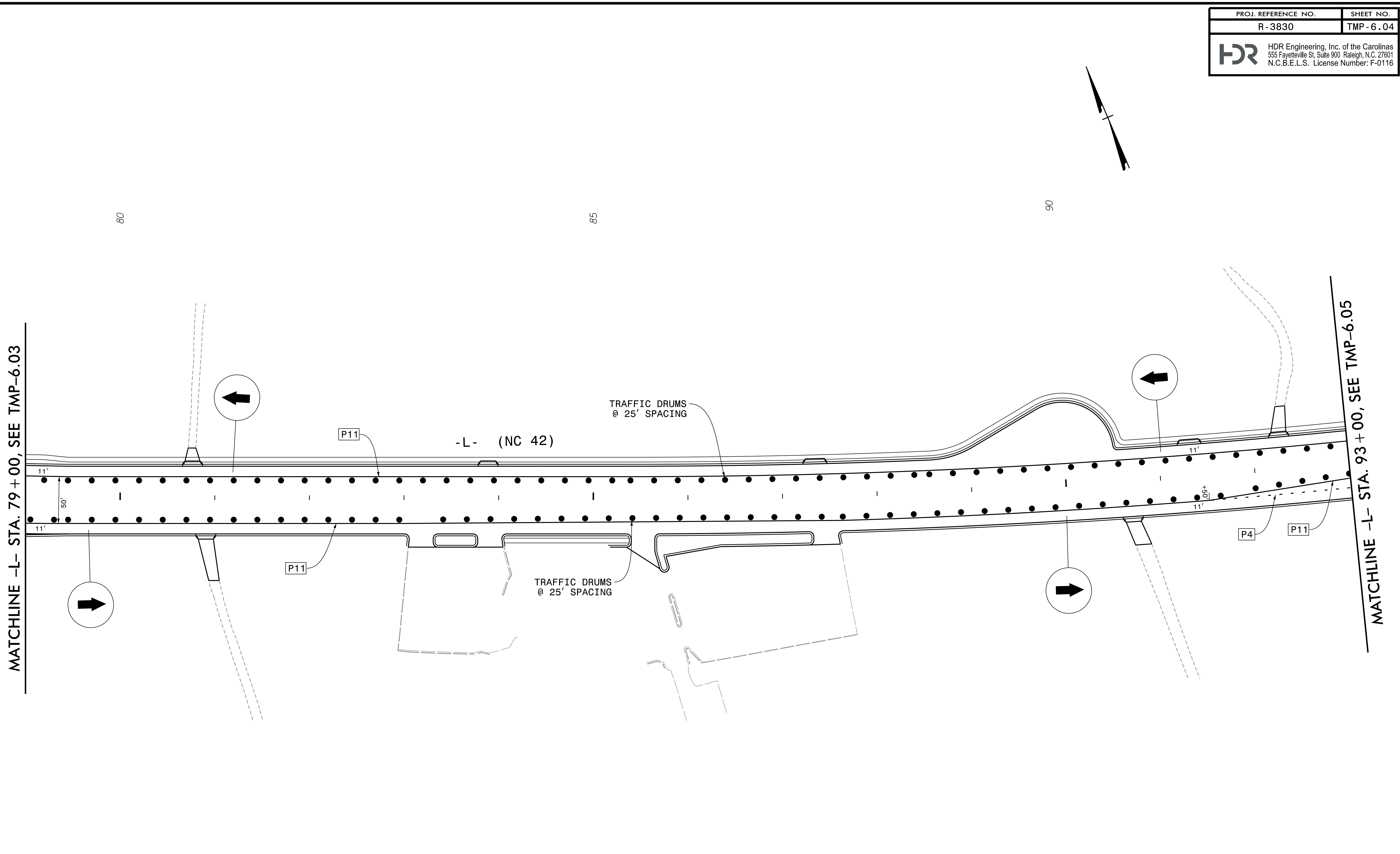
APPROVED: <i>Michael T. Rzepka</i> DATE: 7/12/2022 SEAL 		PHASE 2 - STEP 1
DOCUMENT NOT CONSIDERED FINAL UNLESS ALL SIGNATURES COMPLETED		

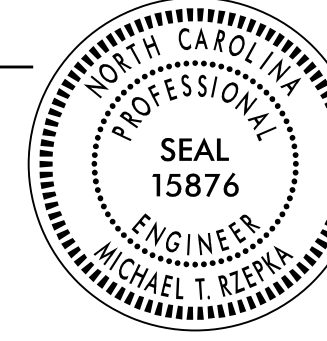

PLOT DRIVER: NCDOT_pdf_color_eng_50.plt PENTABLE: NCDOT_tcp.tbl
 USER: CHARNDEN DATE: 5/4/2022 TIME: 10:49:56 AM
 FILE: p:\pwhdr\users\charnden\Documents\3322\10002133\10279033\6_0_CAD_BIM\6.2_WIP\TrafficControl\CPN\3830_TC_TMP-06.dgn

REVISIONS

APPROVED: <i>Michael T. Rzepka</i> DATE: 7/12/2022 SEAL 		PHASE 2 - STEP 1
DOCUMENT NOT CONSIDERED FINAL UNLESS ALL SIGNATURES COMPLETED		

PLOT DRIVER: NCDOT_pdf_color_eng_50.pit PENTABLE: NCDOT_tcp.tbl
 USER: CHARNDEN DATE: 5/4/2022 TIME: 10:50:05 AM
 FILE: pw:\pwhdr\users\01\HDR_US_East_01\Documents\3322\10002133\10279033\6_0_CAD_BITMAP_6.2.WIP\TrafficControl\CP\R3830_TC_TMP-06_05.dgn

REVISIONS

PROJ. REFERENCE NO.	SHEET NO.
R - 3830	TMP - 6.05
HDR Engineering, Inc. of the Carolinas 555 Fayetteville St, Suite 900 Raleigh, N.C. 27601 N.C.B.E.L.S. License Number: F-0116	

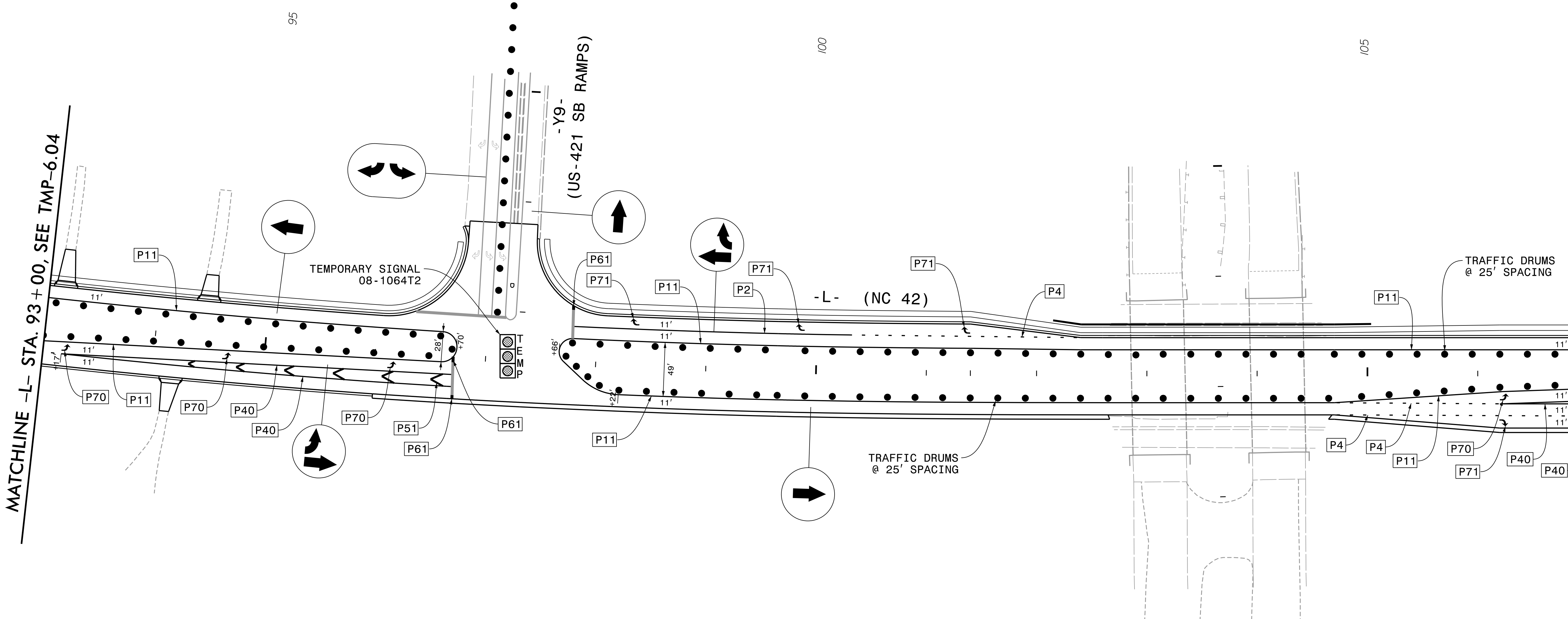
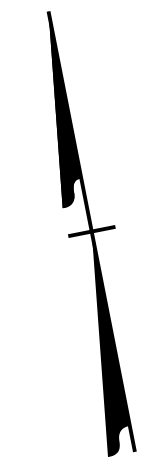

APPROVED: <i>Michael T. Rzepka</i> DATE: 7/12/2022 SEAL		<p style="font-size: small; text-align: center;">NORTH CAROLINA DEPARTMENT OF TRANSPORTATION WORK ZONE TRAFFIC CONTROL</p>	<h2 style="margin: 0;">PHASE 2 - STEP 1</h2>
DOCUMENT NOT CONSIDERED FINAL UNLESS ALL SIGNATURES COMPLETED			

PLOT DRIVER: NCDOT_pdr_color_eng_50.plt PENTABLE: NCDOT_tcp.tbl
 USER: CHARNDEN DATE: 5/4/2022 TIME: 10:50:14 AM
 FILE: p:\pwhdr\uses01\HDR_US_East_01\Documents\3322\10002133\10279033\6_0_CAD.BIM\6.2.WIP\TrafficControl\TCP\3830_TC_TMP-06.dgn

REVISIONS

PROJ. REFERENCE NO.	SHEET NO.
R - 3830	TMP - 6.06
 HDR Engineering, Inc. of the Carolinas 555 Fayetteville St, Suite 900 Raleigh, N.C. 27601 N.C.B.E.L.S. License Number: F-0116	

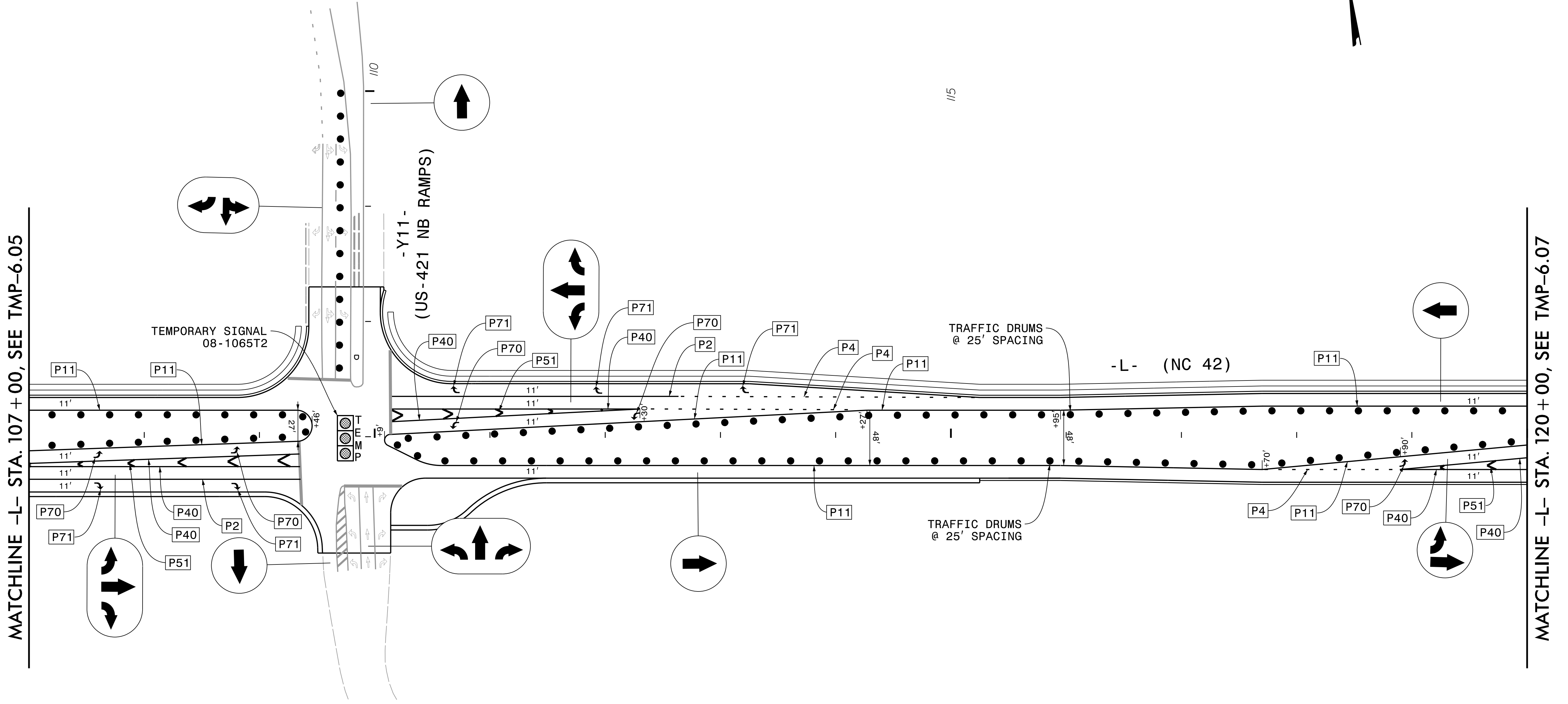
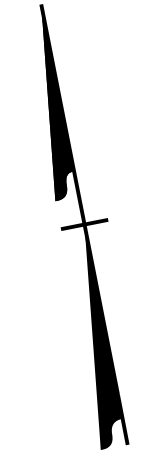

APPROVED: Michael T. Reppa
 DATE: 7/12/2022
 SEAL

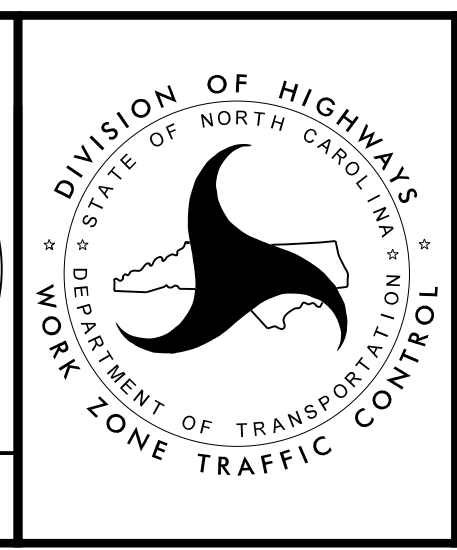
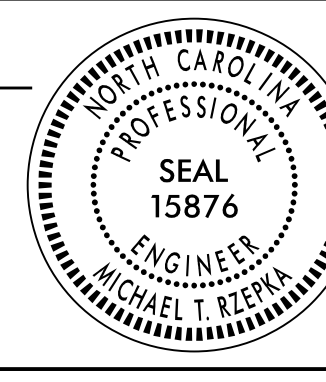

PHASE 2 - STEP 1

**DOCUMENT NOT CONSIDERED FINAL
 UNLESS ALL SIGNATURES COMPLETED**

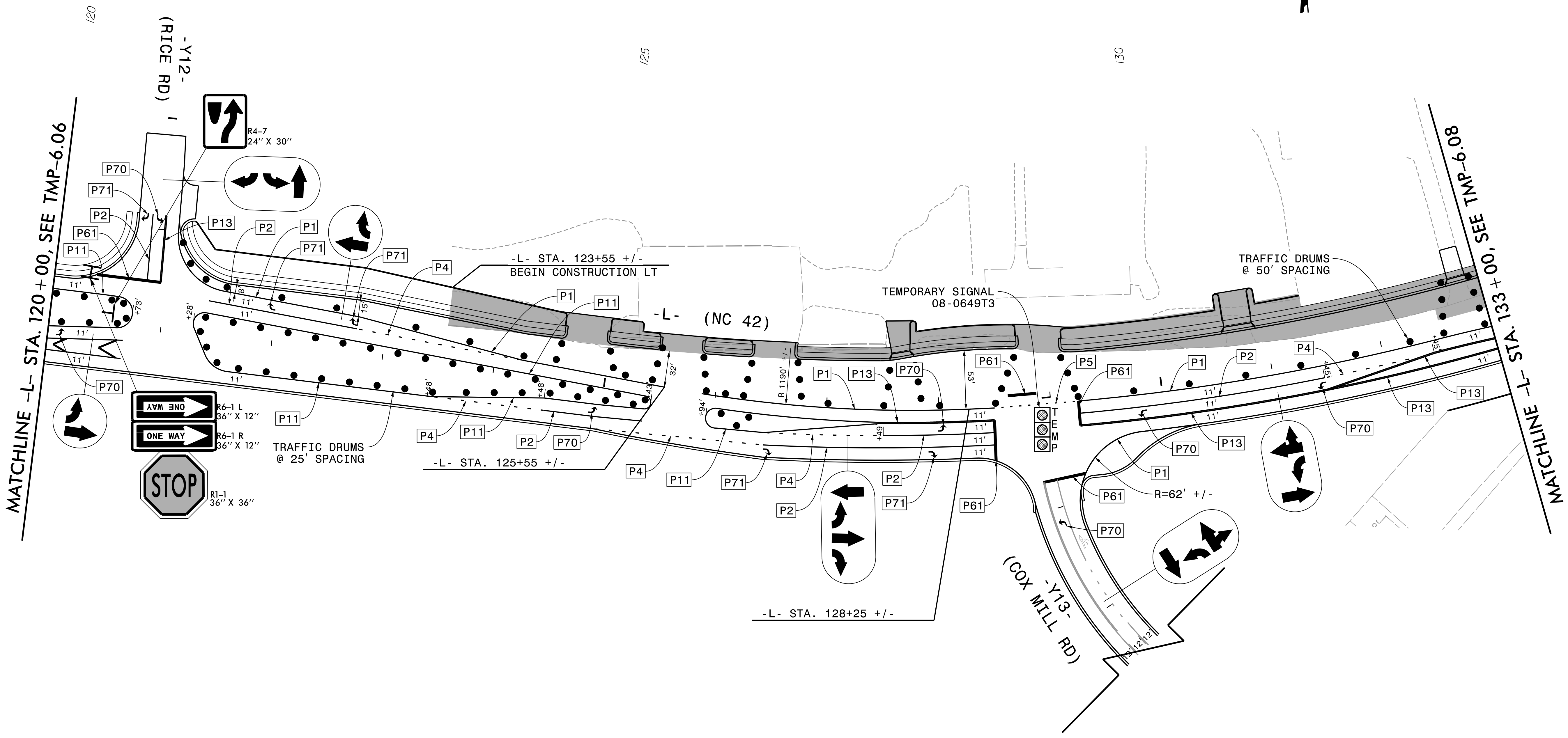
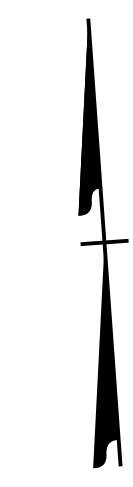

REVISIONS

PLOT DRIVER: NCDOT_pdf_color_eng_50.plt PENTABLE: NCDOT_tcp.tbl
 USER: CHARNDEN DATE: 5/4/2022 TIME: 10:50:23 AM
 FILE: p:\p\hdm\usesas01\hdm\us_east_01\documents\3322\10002133\10279033\6_0_CAD.BIM\6.2.WIP\Traffic\TrafficControl\CP\R3830_TC_TMP-06.07.dgn

APPROVED: *Michael T. Reppa*
 DATE: 7/12/2022

SEAL

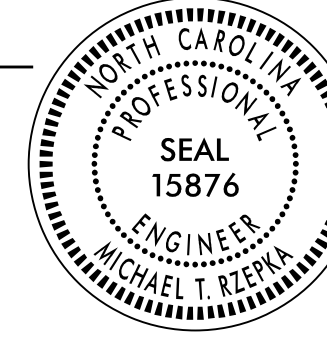

DOCUMENT NOT CONSIDERED FINAL
UNLESS ALL SIGNATURES COMPLETED



PHASE 2 - STEP 1

PLOT DRIVER: NCDOT_pdr_color_eng_50.pit
PENTABLE: NCDOT_tcp.tbl
USER: CHARNDEN
DATE: 5/4/2022
TIME: 10:50:32 AM
FILE: p:\p\pndr\users01\hdf_us_east_01\Documents\3322\10002133\10279033\6_0_CAD_BITMAP6.2\IP\TrafficControl\TCR3830_TC_TMP-06.dgn

REVISIONS

PROJ. REFERENCE NO.	SHEET NO.
R - 3830	TMP - 6.08
HDR Engineering, Inc. of the Carolinas 555 Fayetteville St., Suite 900 Raleigh, N.C. 27601 N.C.B.E.L.S. License Number: F-0116	

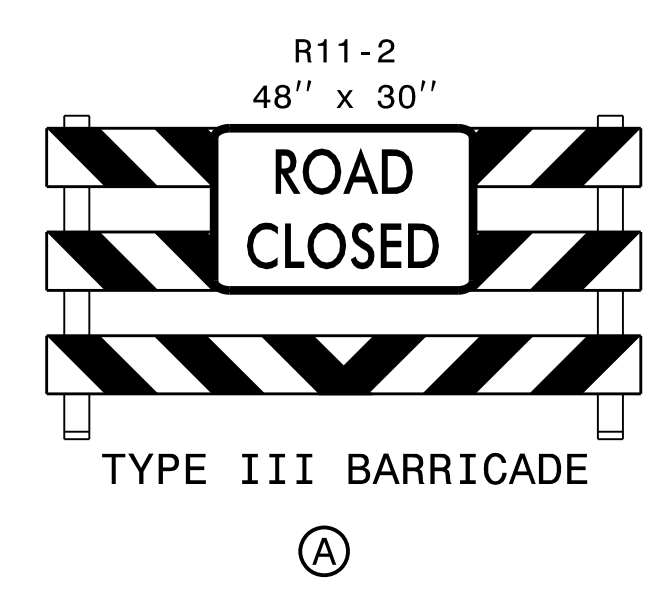
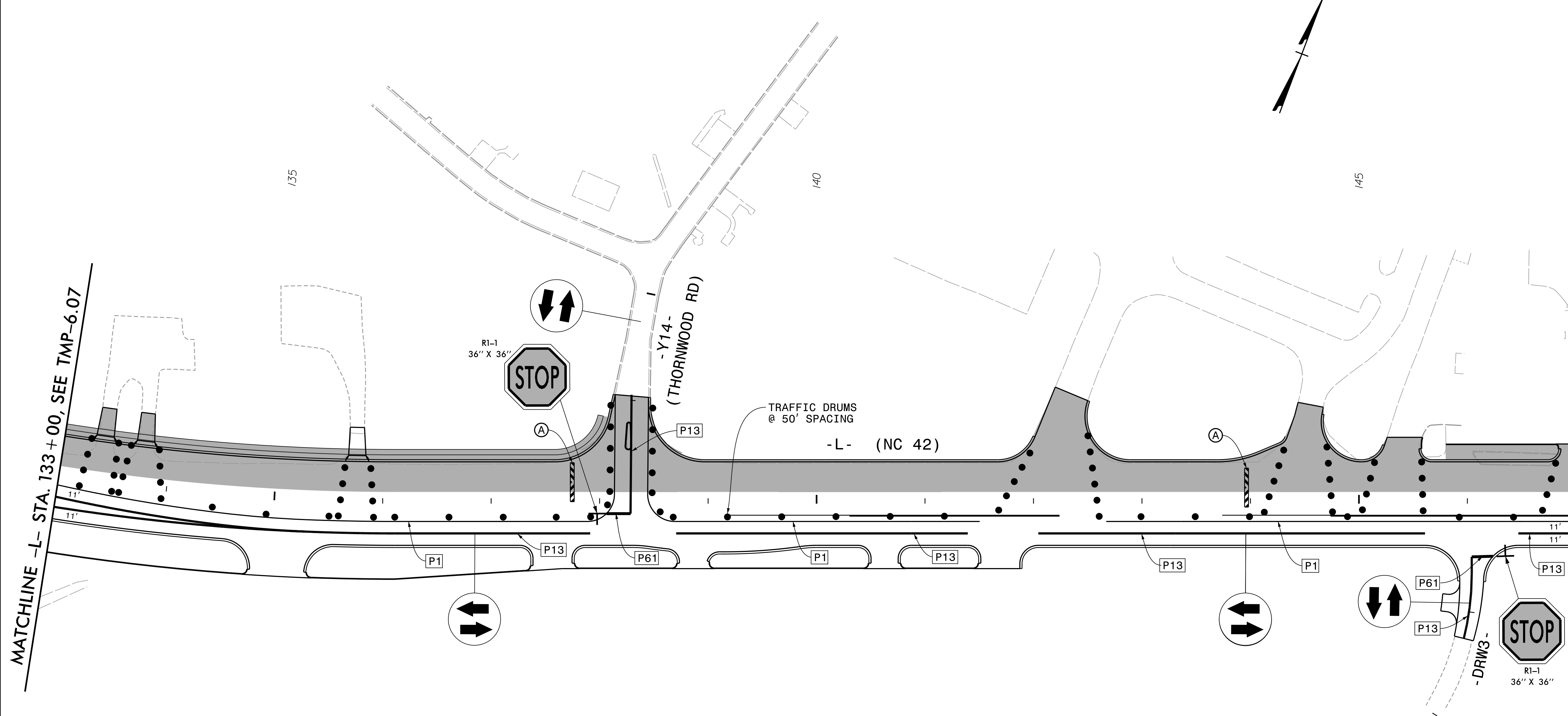

APPROVED: *Michael T. Reppa*
DATE: 7/12/2022
SEAL
NORTH CAROLINA
PROFESSIONAL ENGINEER
SEAL 15876
MICHAEL T. REPPA
ENGINEER



PHASE 2 - STEP 1

DOCUMENT NOT CONSIDERED FINAL
UNLESS ALL SIGNATURES COMPLETED

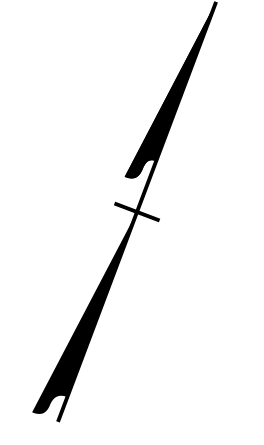

PLOT DRIVER: NCDOT_pdf_color_eng_50.plt
PENTABLE: NCDOT_tcp.tbl
USER: CHARNDEN DATE: 5/4/2022 TIME: 10:50:41 AM
FILE: p:\p\hndr\users\01\hndr_us_east_01\Documents\3322\10002133\10279033\6_0_CAD_BITMAP\6.2_WIP\TrafficControl\TCP\R3830_TC_TMP-06.dgn

REVISIONS

PROJ. REFERENCE NO. R - 3830	SHEET NO. TMP - 6.09
 HDR Engineering, Inc. of the Carolinas 555 Fayetteville St, Suite 900 Raleigh, N.C. 27601 N.C.B.E.L.S. License Number: F-0116	

MATCHLINE -L- STA. 147 + 00, SEE TMP-6.08

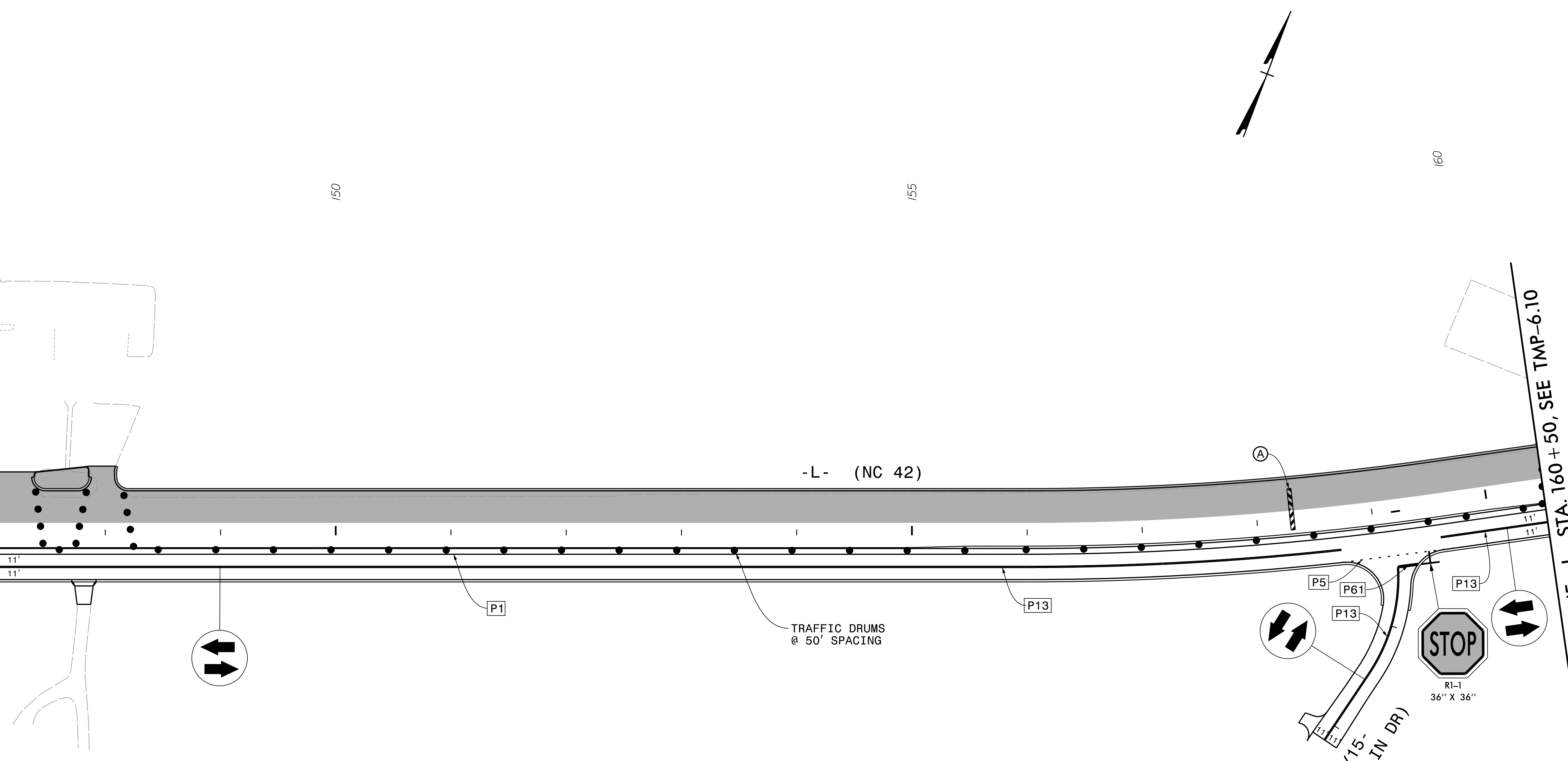

MATCHLINE -L- STA. 160 + 50, SEE TMP-6.10

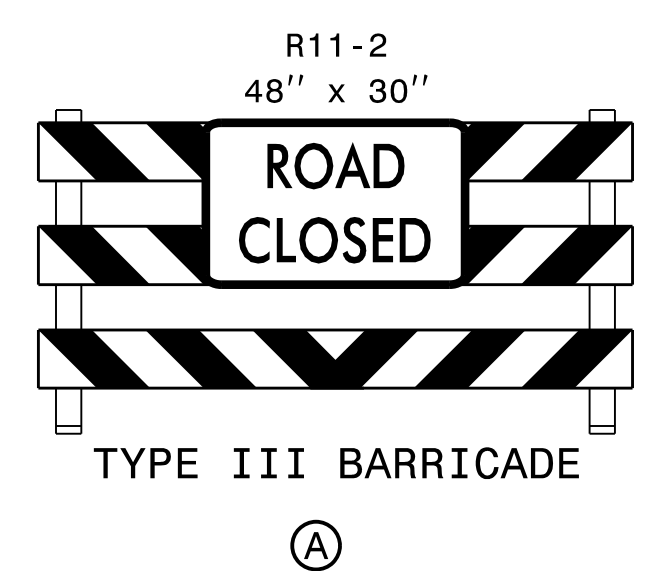

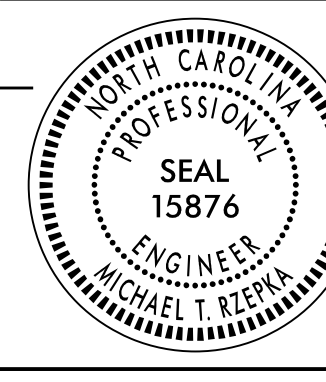
APPROVED: *Michael T. Rzepka*
 DATE: 7/12/2022
 SEAL

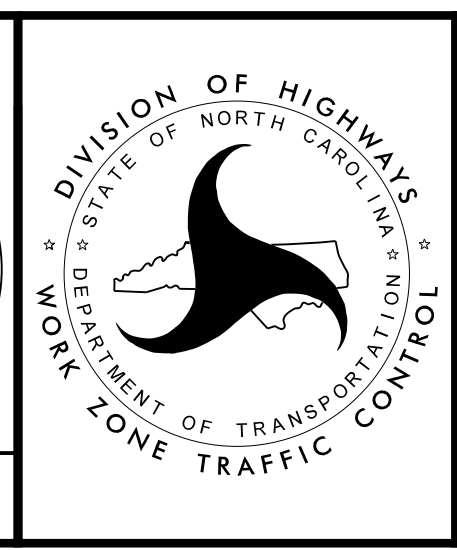

PHASE 2 - STEP 1

PROJ. REFERENCE NO.	SHEET NO.
R-3830	TMP-6.11

HDR HDR Engineering, Inc. of the Carolinas
 555 Fayetteville St., Suite 900 Raleigh, N.C. 27601
 N.C.B.E.L.S. License Number: F-0116

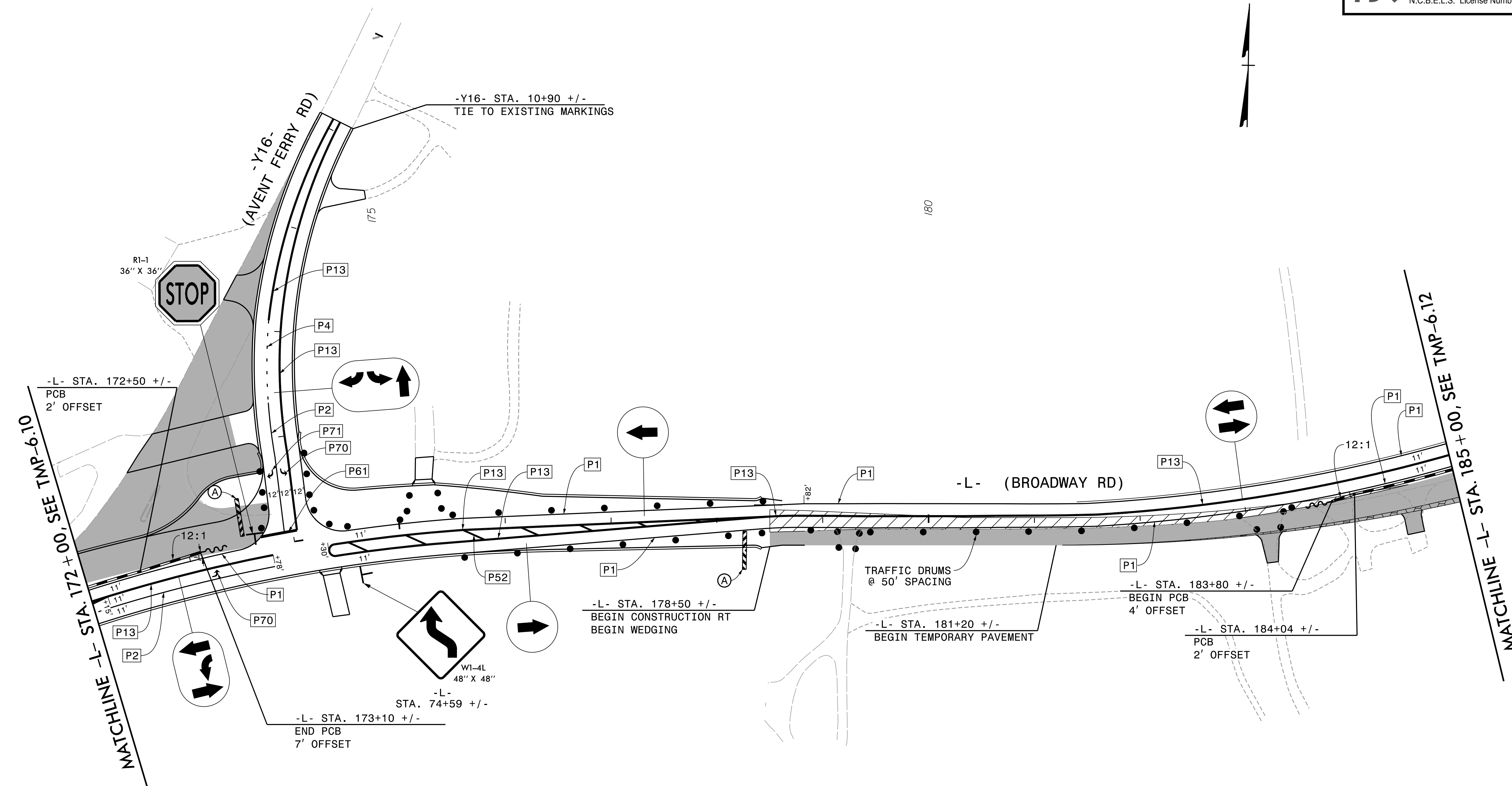

REVISIONS

PLOT DRIVER: NCDOT_pdf_color_eng_50.pit
 USER: CHARNDEN
 DATE: 5/4/2022
 PENTABLE: NCDOT_tcp.tbl
 TIME: 10:50:59 AM
 FILE: p:\pwhdr\users\charnden\us_east\01\Documents\3322\10002133\10279033\6.0_CAD\BIM\6.2_WIP\Traffic\TrafficControl\CP\3830_TC_TMP-06.11.dgn

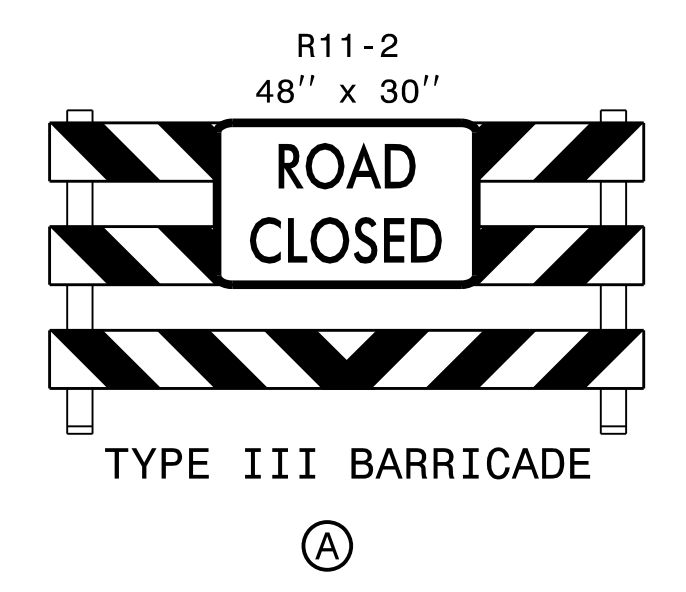

APPROVED: *Michael T. Rzepka*
 DATE: 7/12/2022
 SEAL

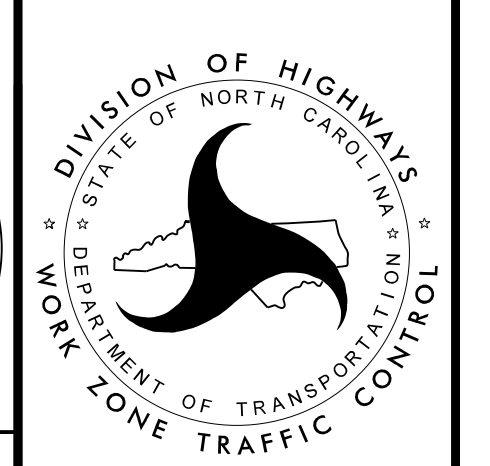
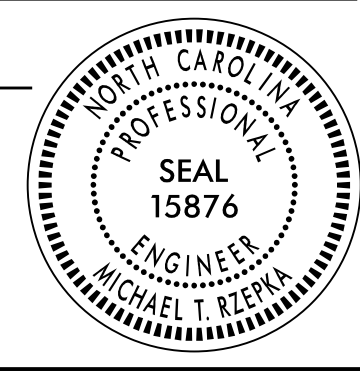

PHASE 2 - STEP 1

DOCUMENT NOT CONSIDERED FINAL
 UNLESS ALL SIGNATURES COMPLETED

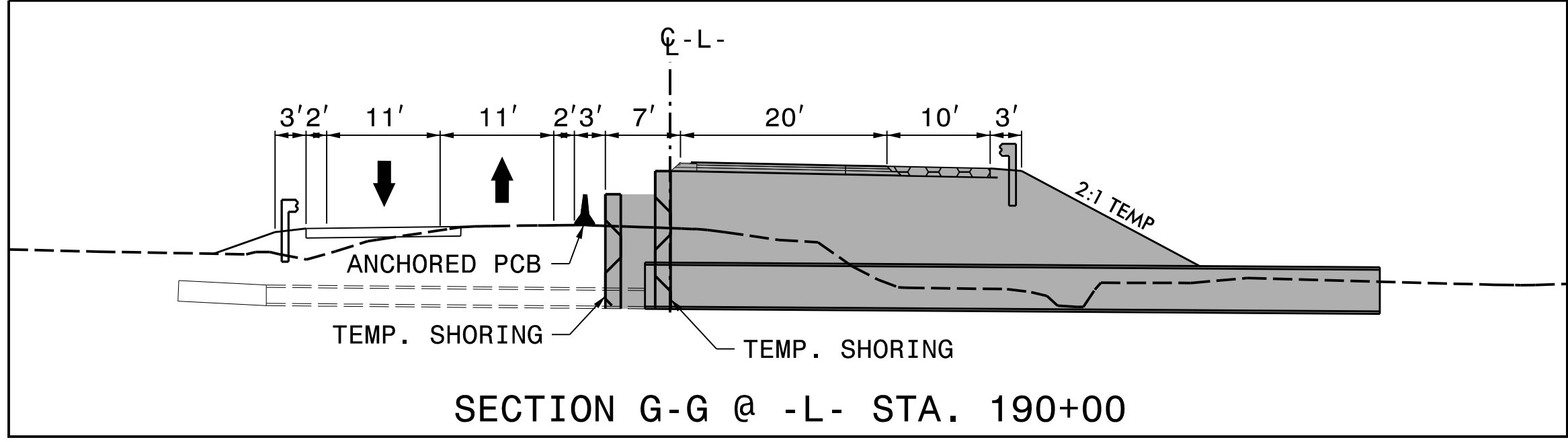
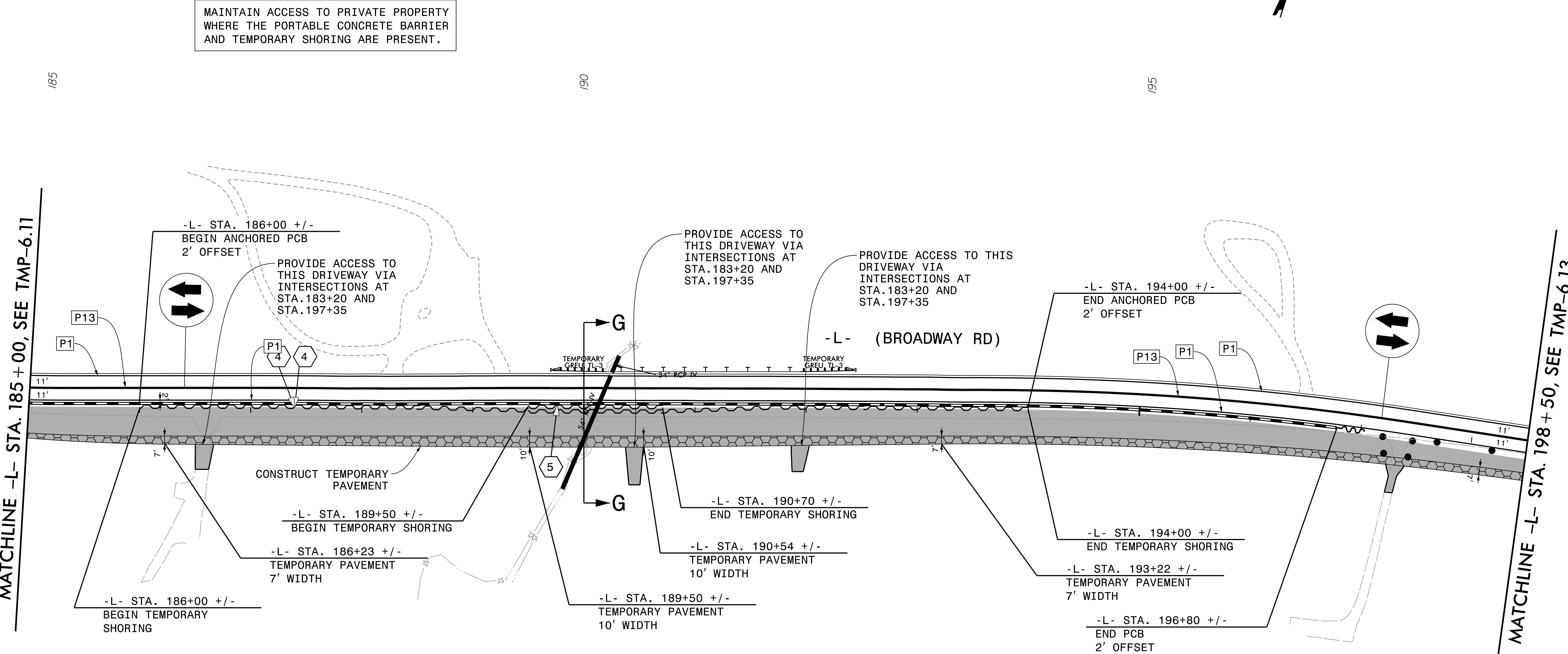

APPROVED: <i>Michael T. Reppke</i> DATE: 7/12/2022 SEAL			PHASE 2 - STEP 1
DOCUMENT NOT CONSIDERED FINAL UNLESS ALL SIGNATURES COMPLETED			

PLOT DRIVER: NCDOT_pdf_color_eng_50.pit
 USER: CHARNDEN
 DATE: 5/4/2022
 FILE: p:\pdr\users\charnden\Documents\3322\10002133\10279033\6.CAD.BIM\6.2.WIP\Traffic\TrafficControl\CPA\R3830_TC_TMP-06.12.dgn

REVISONS

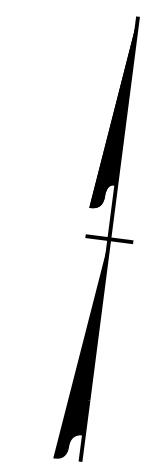



MATCHLINE -L- STA. 198 + 50, SEE TMP-6.12

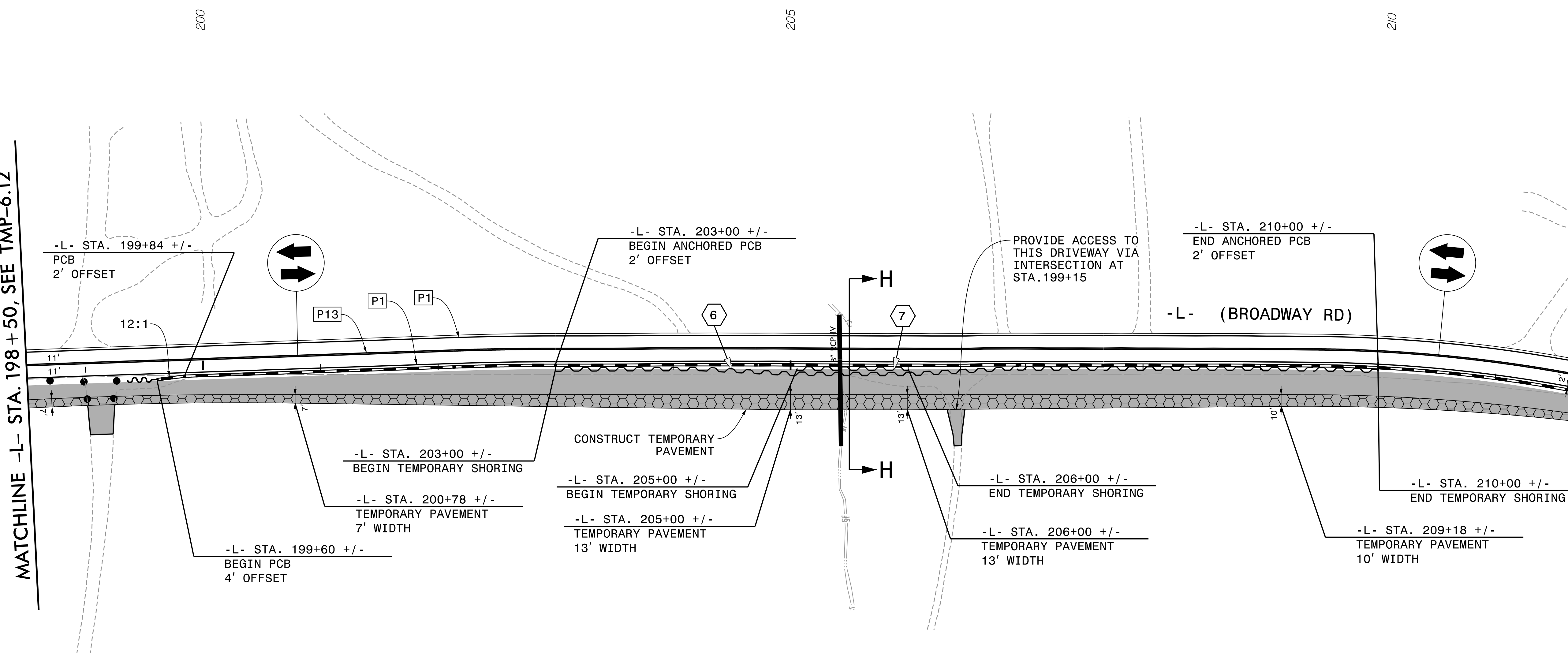

MATCHLINE -L- STA. 212 + 00, SEE TMP-6.14

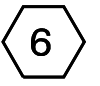

SEE TMP-2A FOR TEMP. SHORING INFORMATION

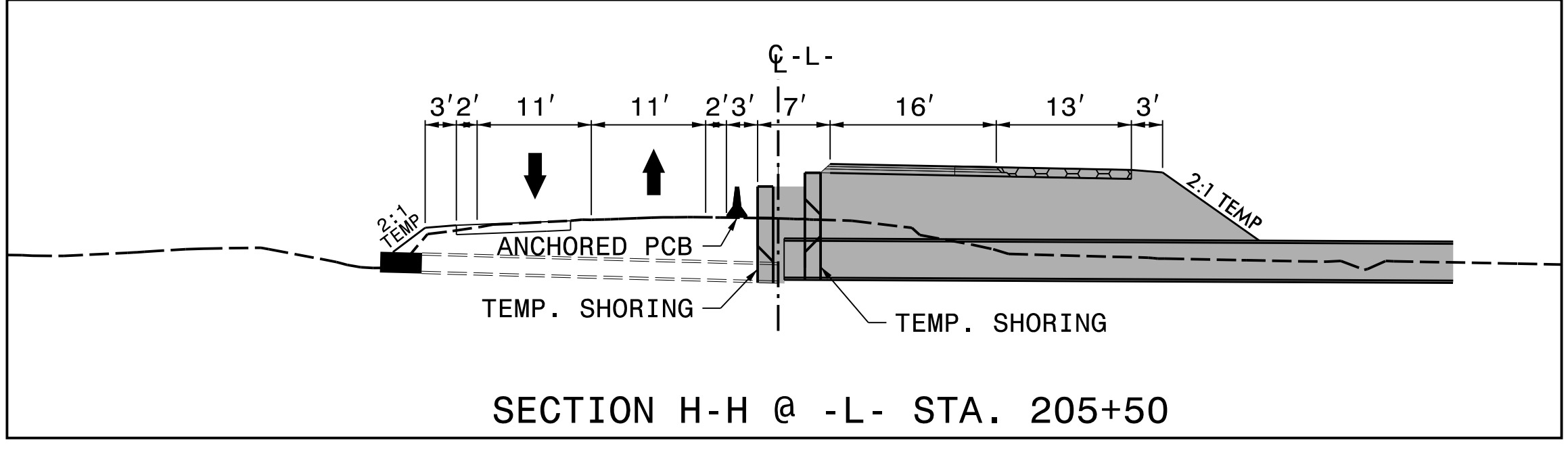
	-L- STA 203+00± 0.4' LT TO STA 210+00±, CENTERLINE QUANTITY = 3500 S.F.
	-L- STA 205+00± 1.3' LT TO STA 206+00±, 0.8' LT QUANTITY = 400 S.F.

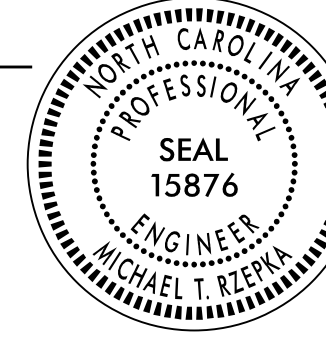

APPROVED: <i>Michael T. Rzepka</i>			<p>PHASE 2 - STEP 1</p>
DATE: 7/12/2022			
<p>DOCUMENT NOT CONSIDERED FINAL UNLESS ALL SIGNATURES COMPLETED</p>			

PLOT DRIVER: NCDOT_pdf_color_eng_50.pit
 USER: CHARNDEN
 DATE: 5/31/2022 TIME: 5:11:50 PM
 FILE: pw:\pndr\usesd01\HDR_US_East.01\Documents\3322\10002133\0279033\6_0_CAD_BITMAP\6.2_WIP\TrafficControl\CP\R3830_TC_TMP-06.13.dgn

REVISONS

10

15

20

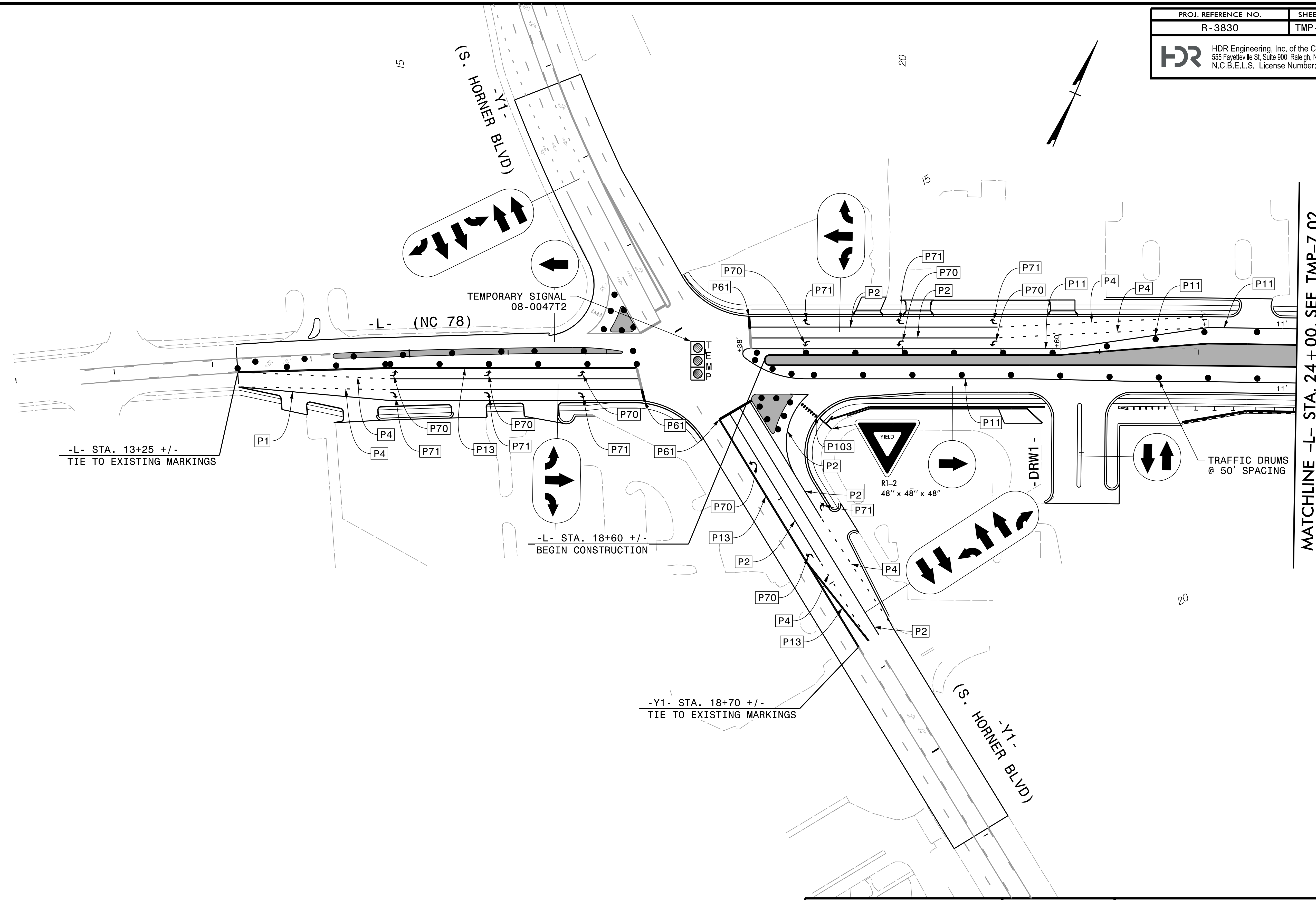
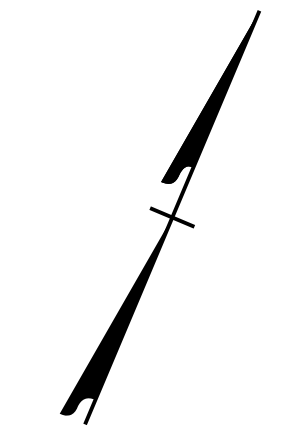

-L- STA. 13+25 +/-
TIE TO EXISTING MARKINGS

TEMPORARY SIGNAL
08-0047T2

-L- STA. 18+60 +/-
BEGIN CONSTRUCTION

-Y1- STA. 18+70 +/-
TIE TO EXISTING MARKINGS

TRAFFIC DRUMS
@ 50' SPACING

MATCHLINE -L- STA. 24+00, SEE TMP-7.02

REVISIONS

PLOT DRIVER: NCDOT_pdf_color_eng_50.pit
 USER: CHARNDEN
 DATE: 5/4/2022
 TIME: 10:51:38 AM
 FILE: p:\w\p\h\p\users\01\HDR_US_East_01\Documents\3322\10002133\10279033\6_0_CAD_BITMAP\6.2_WIP\TrafficControl\TCP\R3830_TC_TMP-07.01.dgn

APPROVED: *Michael T. Rzepka*
 DATE: 7/12/2022
 SEAL
 DOCUMENT NOT CONSIDERED FINAL
 UNLESS ALL SIGNATURES COMPLETED

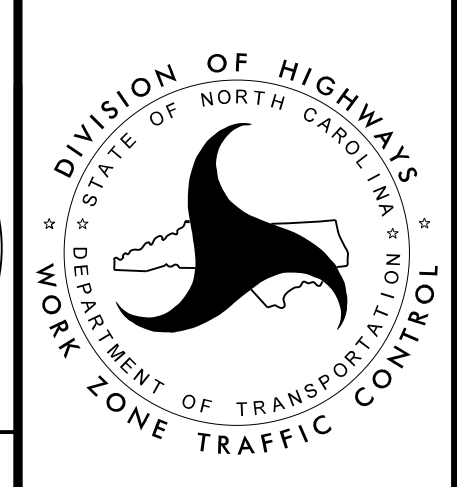
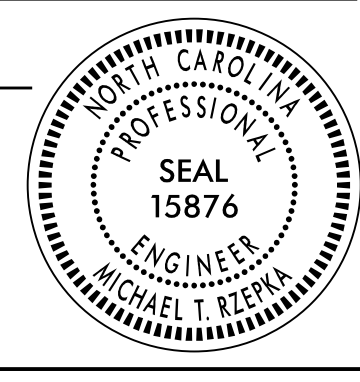

PHASE 3 - STEP 1

PROJ. REFERENCE NO. R - 3830	SHEET NO. TMP - 7.02
 HDR Engineering, Inc. of the Carolinas 555 Fayetteville St., Suite 900 Raleigh, N.C. 27601 N.C.B.E.L.S. License Number: F-0116	

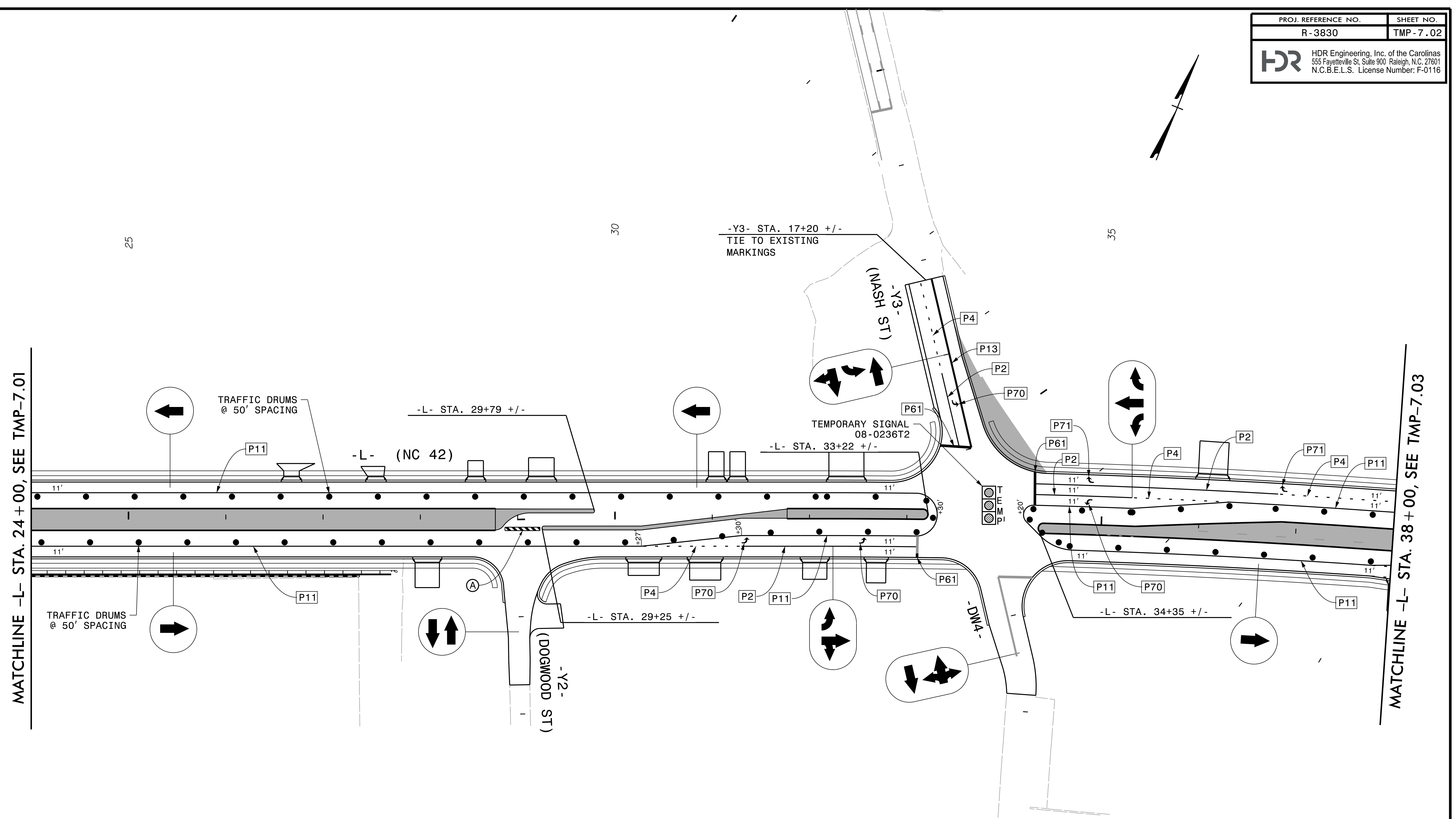

MATCHLINE -L- STA. 24 + 00, SEE TMP-7.01

MATCHLINE -L- STA. 38 + 00, SEE TMP-7.03

25

30

35

-Y3- STA. 17+20 +/-
TIE TO EXISTING
MARKINGS

-L- STA. 29+79 +/-

TEMPORARY SIGNAL
08-0236T2
-L- STA. 33+22 +/-

-L- (NC 42)

-L- STA. 29+25 +/-

-L- STA. 34+35 +/-

TRAFFIC DRUMS
@ 50' SPACING

TRAFFIC DRUMS
@ 50' SPACING

-Y2-
(DOGWOOD ST)

-DM4-

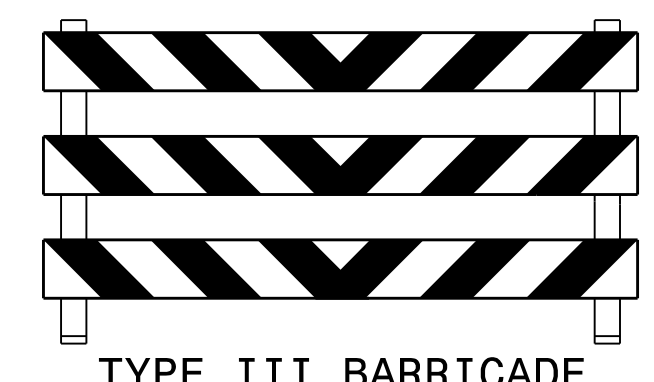

TYPE III BARRICADE

(A)

APPROVED: *Michael T. Reppa*

DATE: 7/12/2022

SEAL

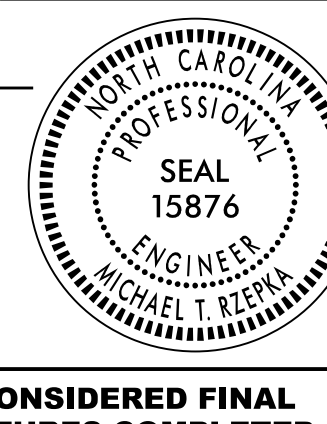

**DOCUMENT NOT CONSIDERED FINAL
UNLESS ALL SIGNATURES COMPLETED**

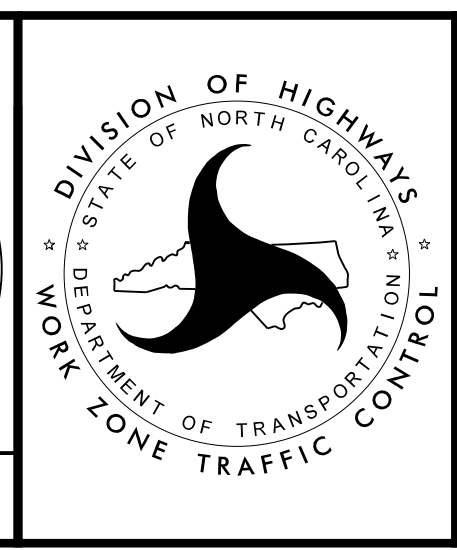

PHASE 3 - STEP 1

REVISIONS

PLOT DRIVER: NCDOT_pdf_color_eng_50.pit PENTABLE: NCDOT_tcp.tbl
 USER: CHARNDEN DATE: 5/4/2022 TIME: 10:51:48 AM
 FILE: p:\p\pwhdr\usesd01\HDR_US_East_01\Documents\3322\10002133\10279033\6_0_CAD.BIM\6.2.WIP\Traffic\TrafficControl\TCP\R3830_TC_TMP-07.dgn

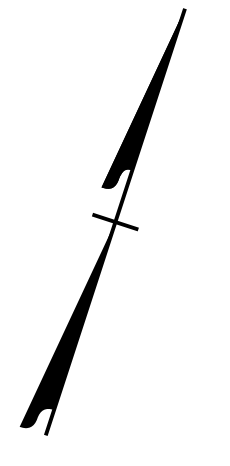

40

45

50

MATCHLINE -L- STA. 38 + 00, SEE TMP-7.02

MATCHLINE -L- STA. 52 + 00, SEE TMP-7.04

MATCHLINE -Y5- STA. 13 + 50, SEE TMP-7.22

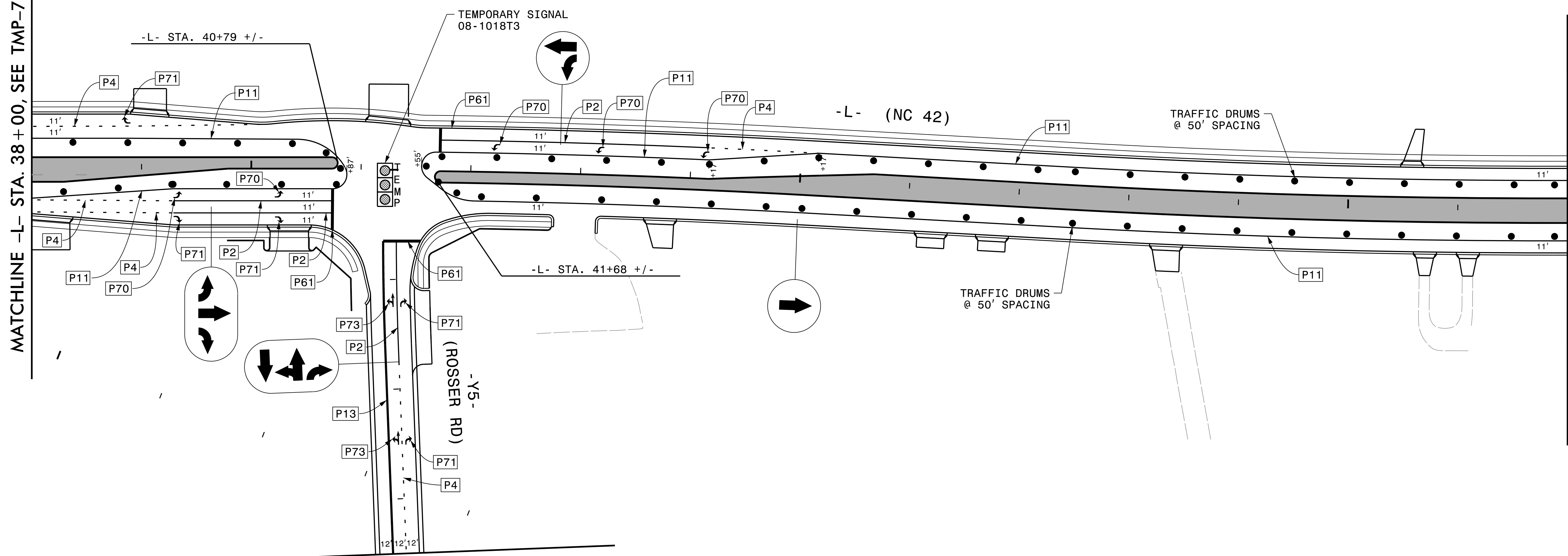

REVISIONS

PLOT DRIVER: NCDOT_pdf_color_eng_50.pit
 USER: CHARNDEN
 DATE: 5/4/2022
 TIME: 10:51:58 AM
 FILE: p:\p\h\dr\uses\01\HDR-US-East-01\Documents\3322\10002133\10279033\6.0.CAD.BIM\6.2.WIP\TrafficControl\CPAR3830_TC_TMP-07.03.dgn

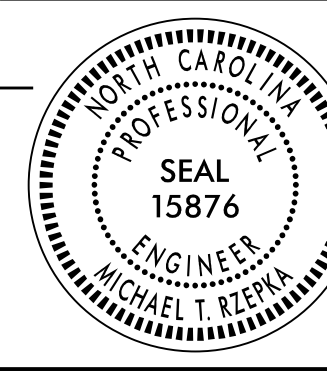
APPROVED: *Michael T. Rzepka*
 DATE: 7/12/2022
 SEAL

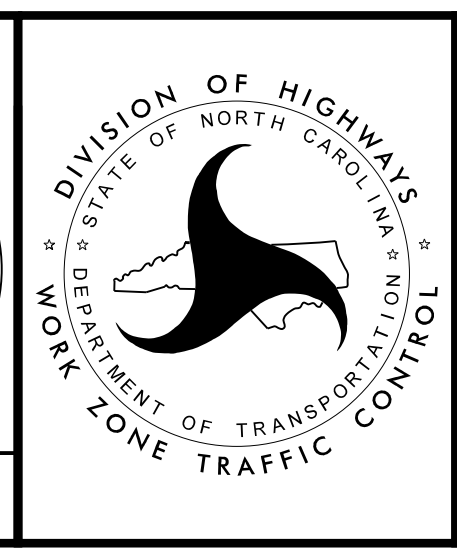

PHASE 3 - STEP 1

DOCUMENT NOT CONSIDERED FINAL UNLESS ALL SIGNATURES COMPLETED

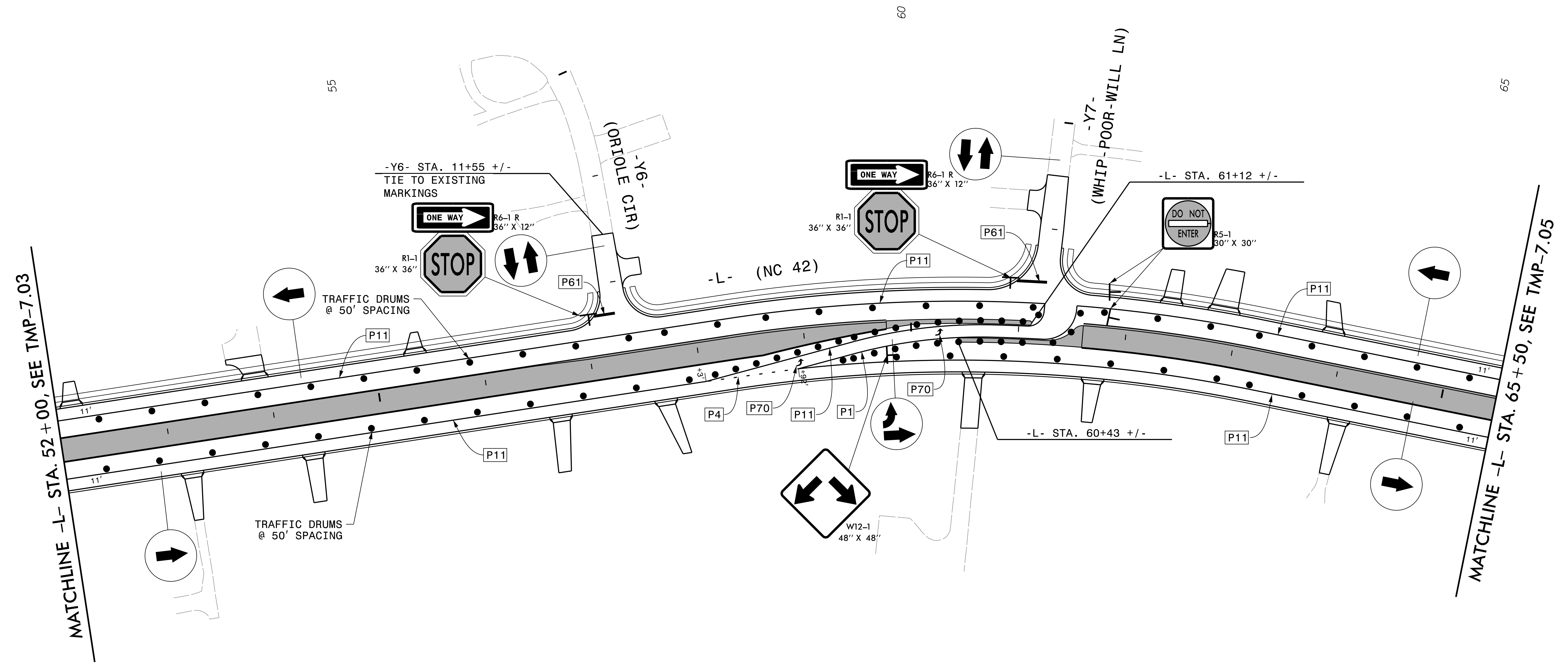
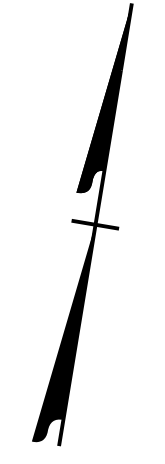

PLOT DRIVER: NCDOT_pdf_color_eng_50.plt
 USER: CHARNDEN
 DATE: 5/4/2022
 TIME: 10:52:08 AM
 FILE: p:\pwhdr\users\charnden\us_east_01\Documents\3322\10002133\10279033\6_0_CAD_BIM\6.2_WIP\Traffic\TrafficControl\TCP\R3830_TC_TMP-07.04.dgn

REVISIONS

APPROVED: *Michael T. Rzepka*

DATE: 7/12/2022

SEAL

**DOCUMENT NOT CONSIDERED FINAL
UNLESS ALL SIGNATURES COMPLETED**

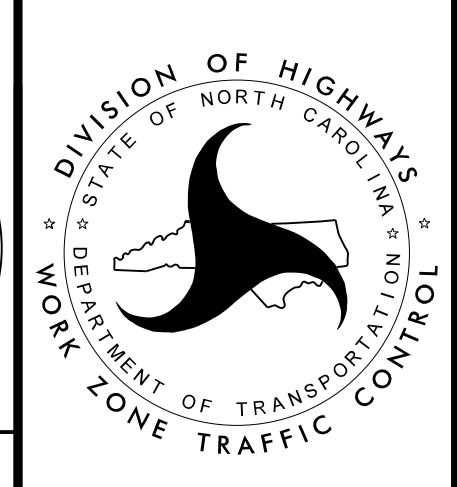
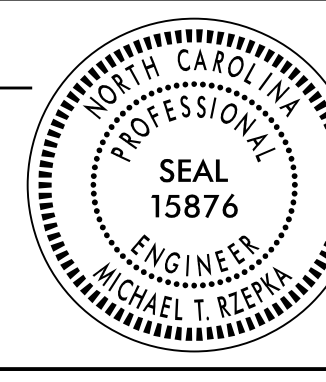

PHASE 3 - STEP 1

PROJ. REFERENCE NO. R - 3830	SHEET NO. TMP - 7.05
 HDR Engineering, Inc. of the Carolinas 555 Fayetteville St, Suite 900 Raleigh, N.C. 27601 N.C.B.E.L.S. License Number: F-0116	

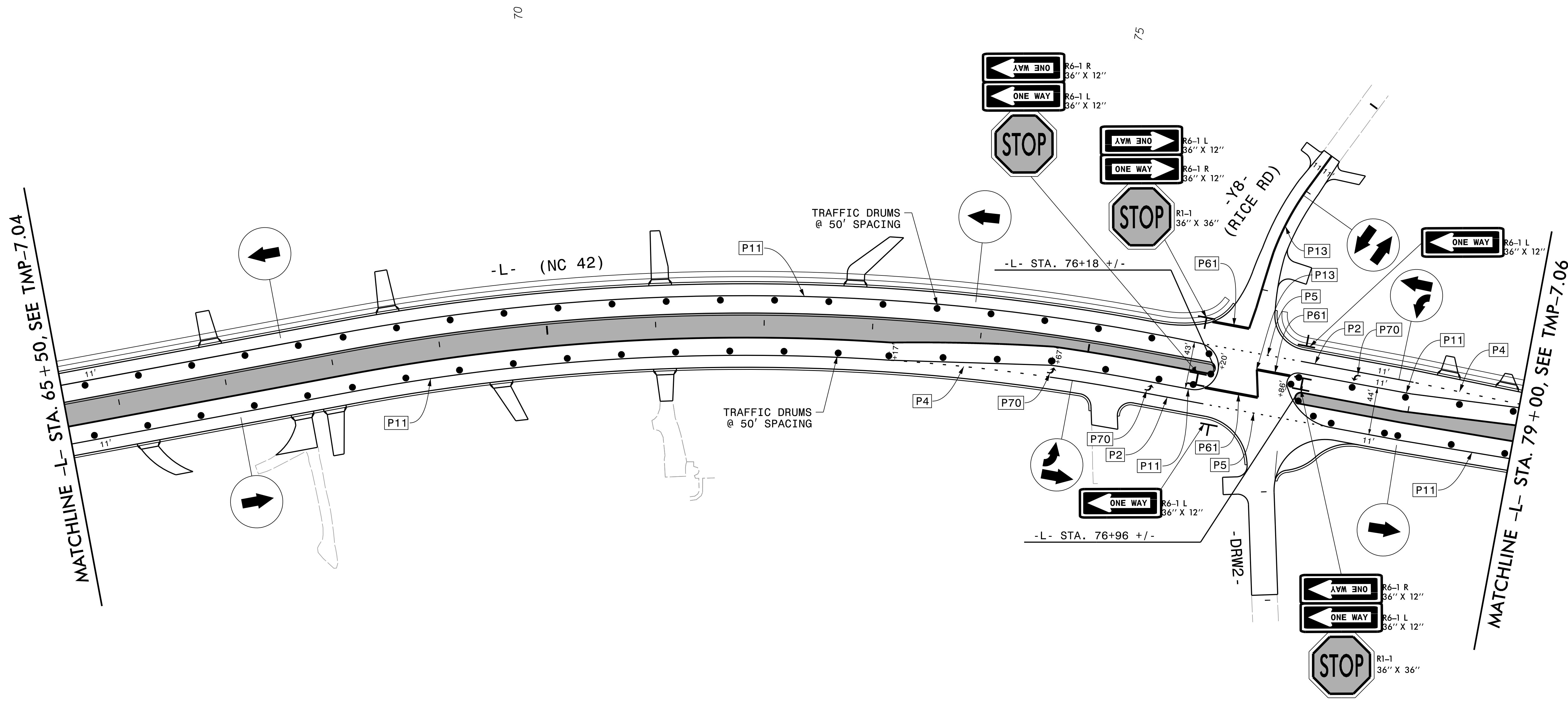
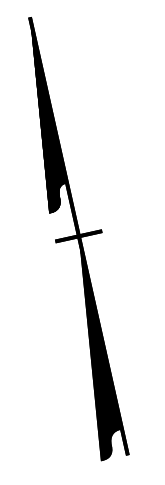

REVISIONS

PLOT DRIVER: NCDOT_pdf_color_eng_50.pit
 USER: CHARNDEN
 DATE: 5/4/2022
 PENTABLE: NCDOT_tcp.tbl
 TIME: 10:52:18 AM
 FILE: p:\p\hndr\users\charnden\Documents\3322\10002133\10279033\6_0_CAD_BIM\6_2_WIP\Traffic\TrafficControl\TCP\R3830_TC_TMP-07_05.dgn

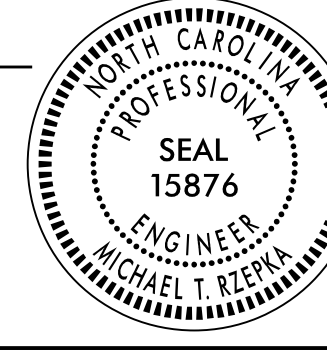
APPROVED: *Michael T. Respha*
 DATE: 7/12/2022
 SEAL

 DOCUMENT NOT CONSIDERED FINAL
 UNLESS ALL SIGNATURES COMPLETED

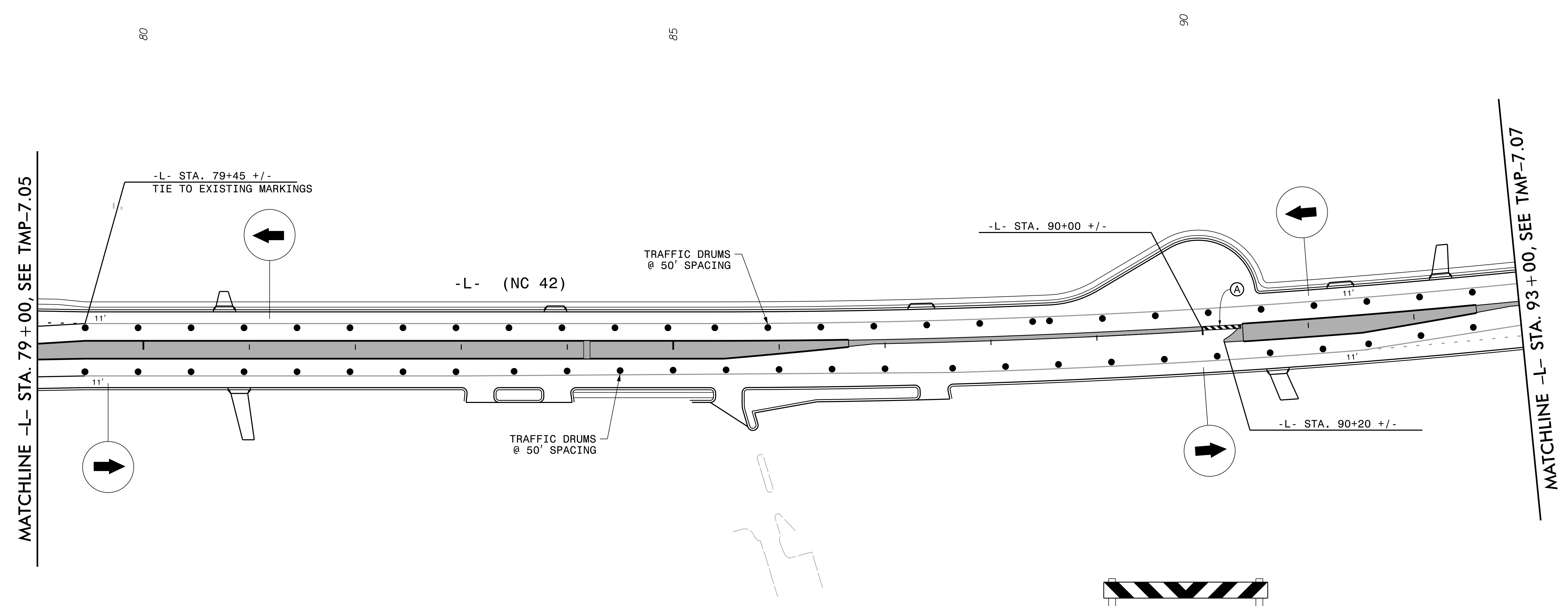
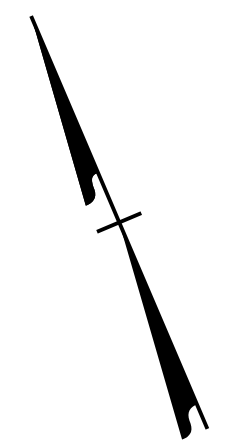

PHASE 3 - STEP 1

PROJ. REFERENCE NO.	SHEET NO.
R - 3830	TMP - 7.06
 HDR Engineering, Inc. of the Carolinas 555 Fayetteville St, Suite 900 Raleigh, N.C. 27601 N.C.B.E.L.S. License Number: F-0116	



REVISIONS

PLOT DRIVER: NCDOT_pdf_color_eng_50.plt
 USER: CHARNDEN
 DATE: 5/4/2022
 TIME: 10:52:29 AM
 FILE: p:\pwhdr\users\charnden\Documents\3322\10002133\10279033\6_0_CAD.BIM\6.2.WIP\TrafficControl\CPN\3830_TC_TMP-07.06.dgn

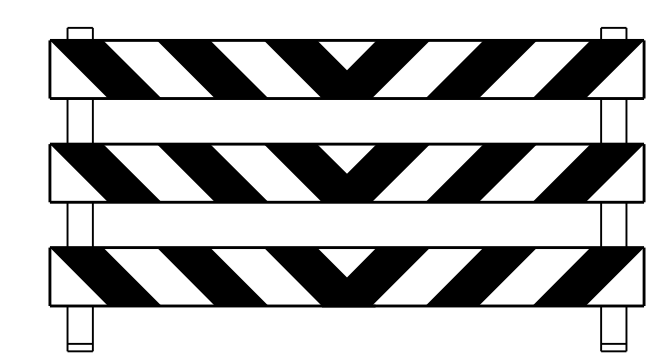

TYPE III BARRICADE

(A)

APPROVED: *Michael T. Rzepka*
 DATE: 7/12/2022
 SEAL

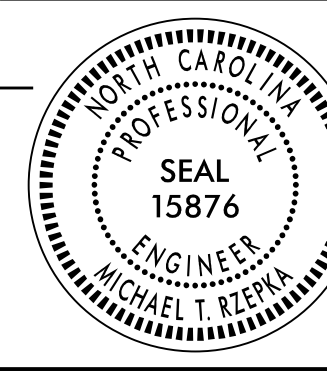
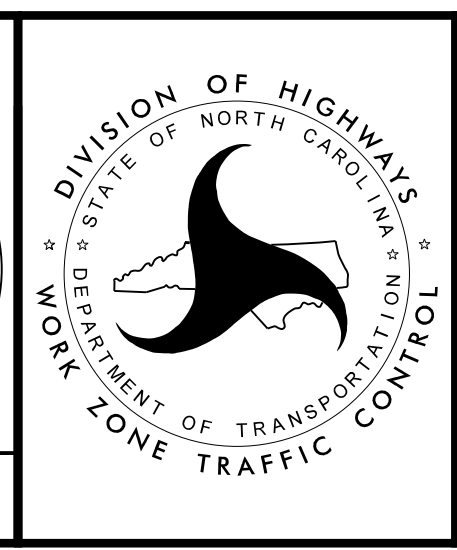
PHASE 3 - STEP 1

DOCUMENT NOT CONSIDERED FINAL
 UNLESS ALL SIGNATURES COMPLETED

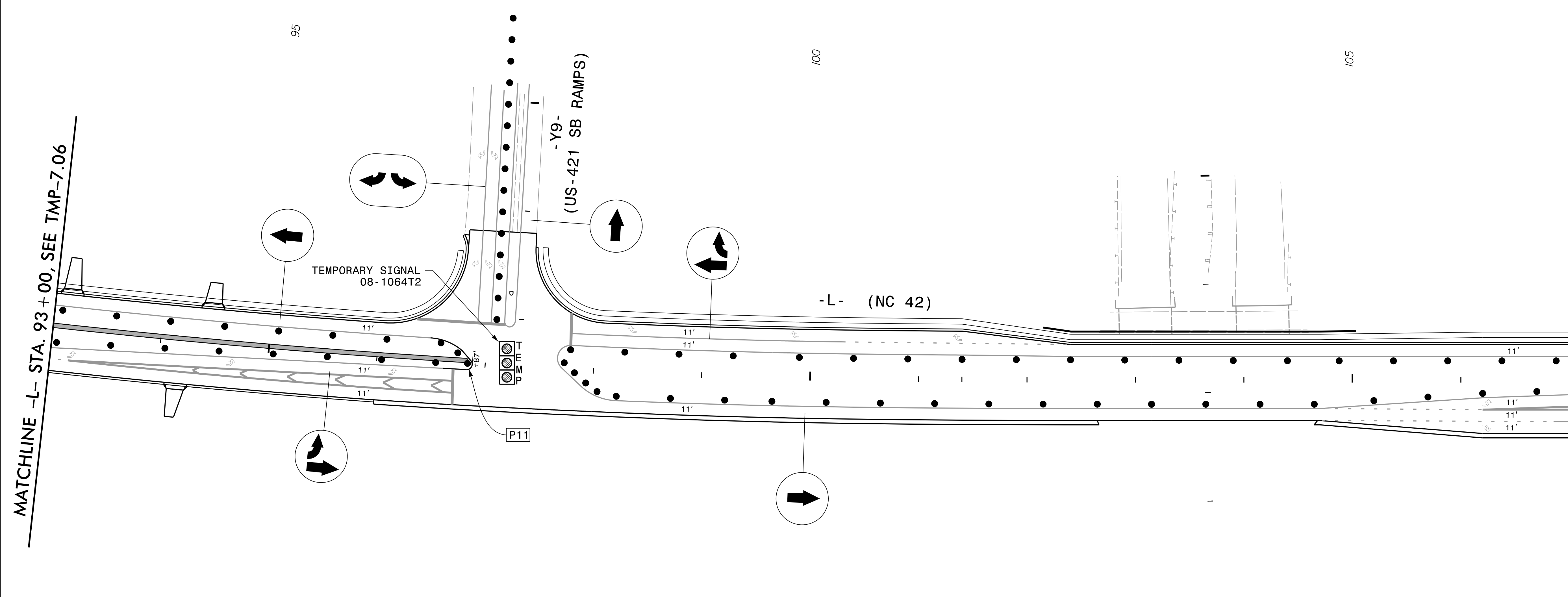
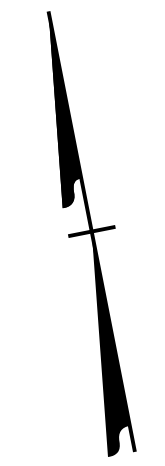

REVISIONS

PLOT DRIVER: NCDOT_pdf_color_eng_50.plt
 USER: CHARNDEN
 DATE: 5/4/2022
 PENTABLE: NCDOT_tcp.tbl
 TIME: 10:52:39 AM
 FILE: p:\p\h\p\users\charnd\us_east_01\Documents\3322\10002133\10279033\6_0_CAD_BITMAP\6.2_WIP\TrafficControl\CP\R3830_TC_TMP-07.dgn

APPROVED: *Michael T. Rzepka*
 DATE: 7/12/2022
 SEAL

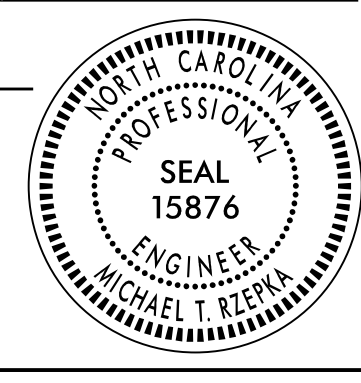

PHASE 3 - STEP 1

**DOCUMENT NOT CONSIDERED FINAL
 UNLESS ALL SIGNATURES COMPLETED**

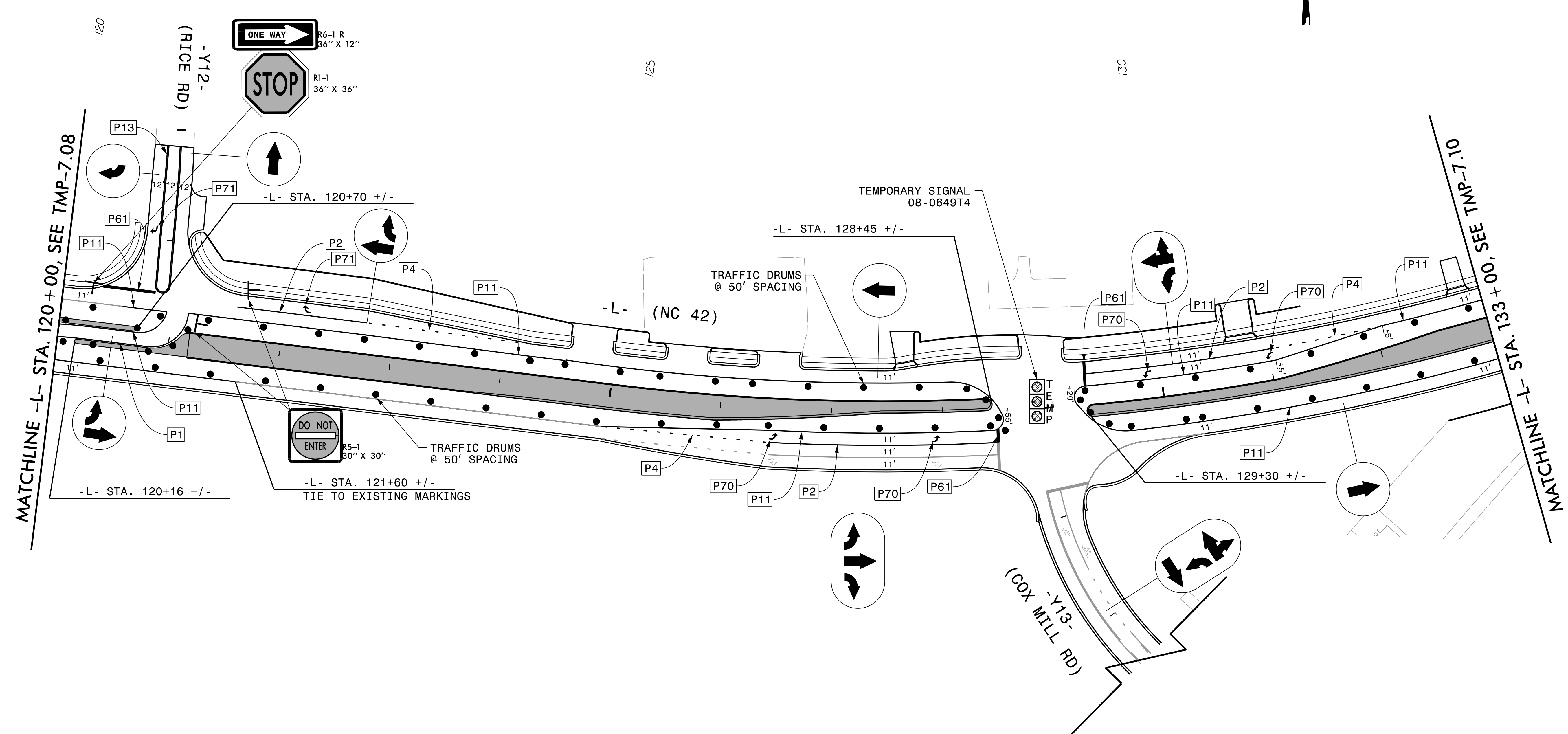
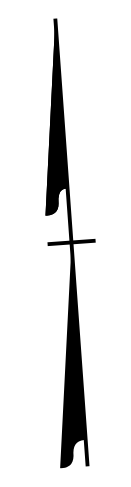

REVISIONS

PLOT DRIVER: NCDOT_pdf_color_eng_50.plt
USER: CHARNDEN
FILE: p:\p\hndr\usesds01\hnr-us-east-01\documents\3322\10002133\10279033\6_0_CAD_BITMAP\6.2_WIP\TrafficControl\CP\R3830_TC_TMP-07.09.dgn
PENTABLE: NCDOT_tcp.tbl
DATE: 5/4/2022
TIME: 10:53:00 AM

APPROVED: *Michael T. Respha*
DATE: 7/12/2022
SEAL
NORTH CAROLINA PROFESSIONAL ENGINEER SEAL 15876
MICHAEL T. RESPHA

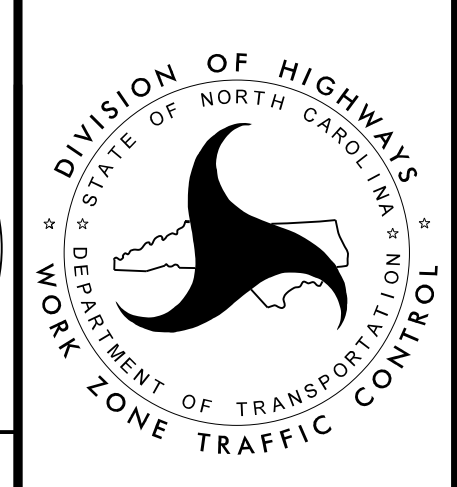

PHASE 3 - STEP 1
DOCUMENT NOT CONSIDERED FINAL
UNLESS ALL SIGNATURES COMPLETED

PROJ. REFERENCE NO.	SHEET NO.
R-3830	TMP-7.10

HDR HDR Engineering, Inc. of the Carolinas
 555 Fayetteville St, Suite 900 Raleigh, N.C. 27601
 N.C.B.E.L.S. License Number: F-0116

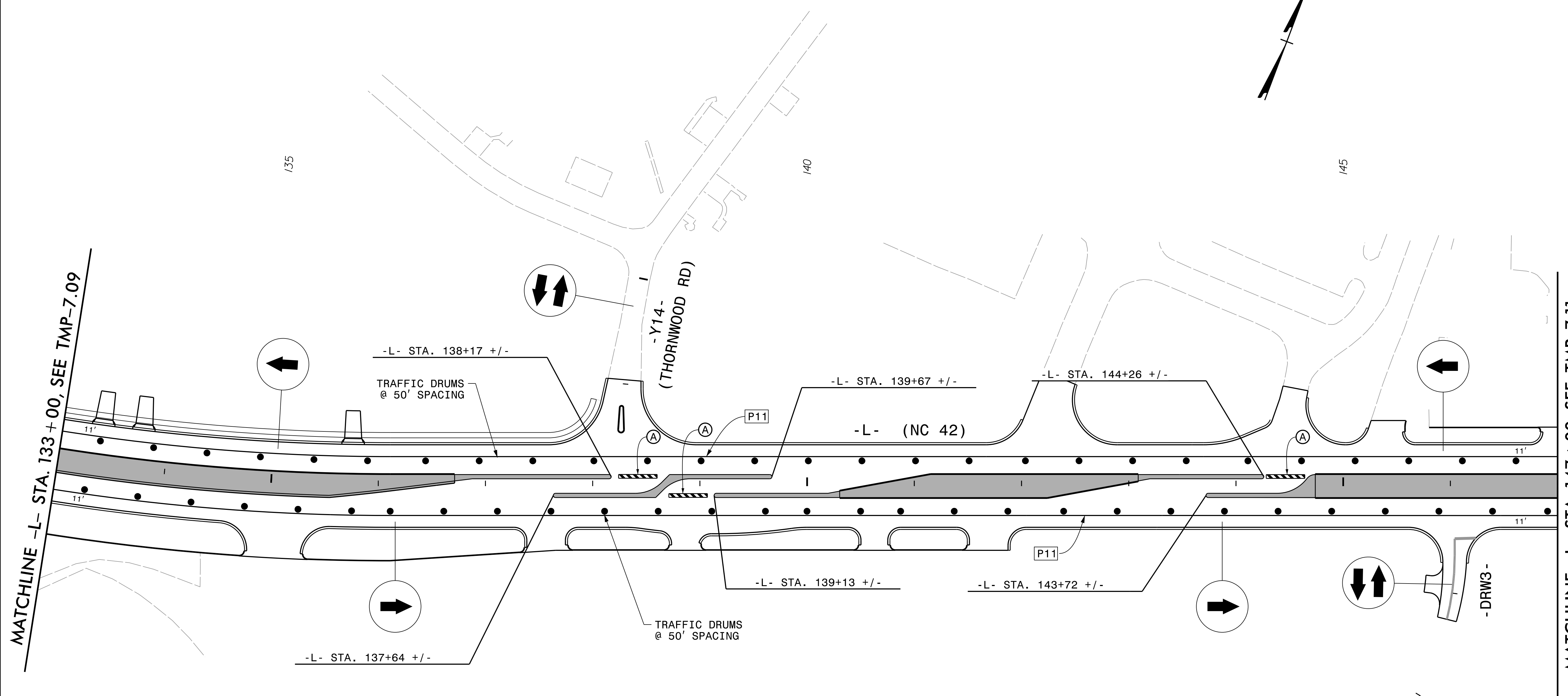
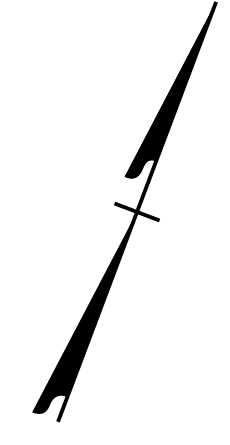

REVISIONS

PLOT DRIVER: NCDOT_pdf_color_eng_50.plt
 USER: CHARNDEN
 DATE: 5/4/2022
 PENTABLE: NCDOT_tcp.tbl
 TIME: 10:53:11 AM
 FILE: p:\p\h\p\users\charnden\us_east\01\Documents\3322\10002133\10279033\6_0_CAD_BITMAP\6.2.WIP\TrafficControl\CPAR3830_TC_TMP-07.10.dgn

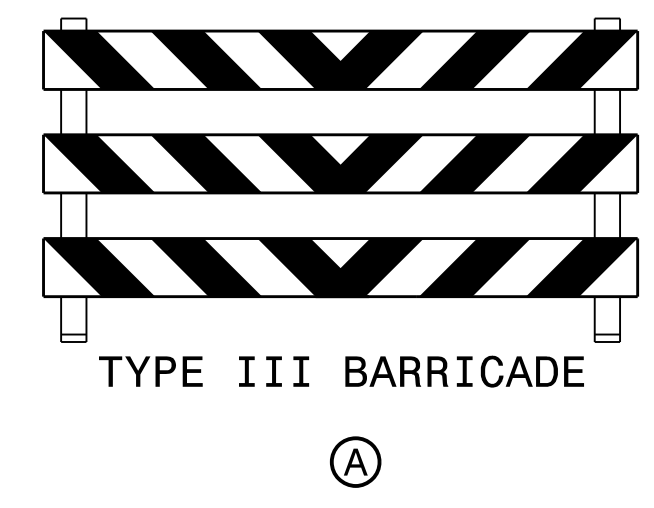

APPROVED: *Michael T. Reppa*
 DATE: 7/12/2022

SEAL

**DOCUMENT NOT CONSIDERED FINAL
UNLESS ALL SIGNATURES COMPLETED**

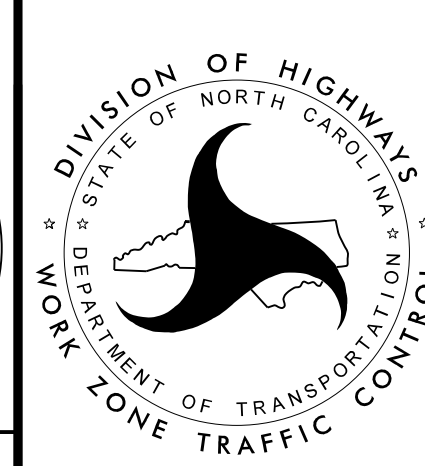

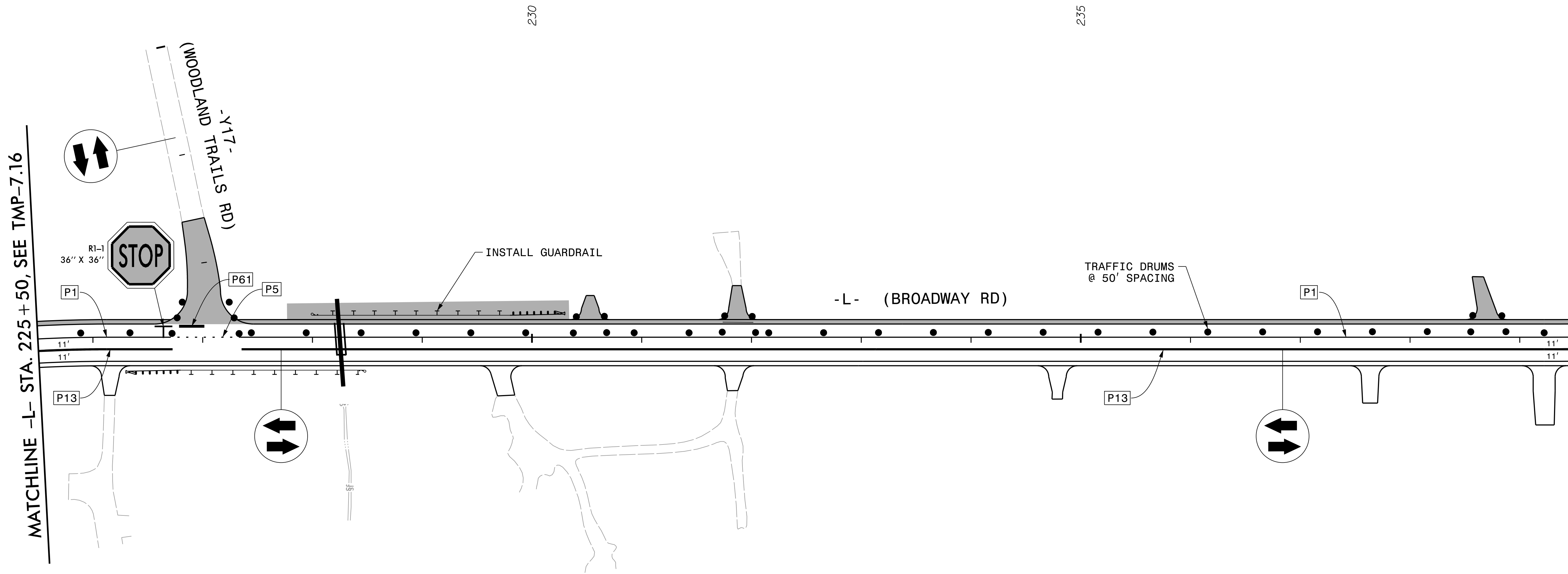
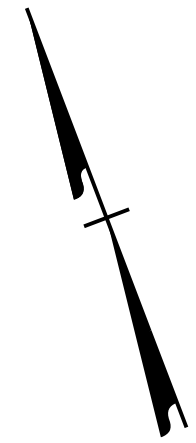

PHASE 3 - STEP 1

PROJ. REFERENCE NO. R - 3830	SHEET NO. TMP - 7.17
 HDR Engineering, Inc. of the Carolinas 555 Fayetteville St, Suite 900 Raleigh, N.C. 27601 N.C.B.E.L.S. License Number: F-0116	

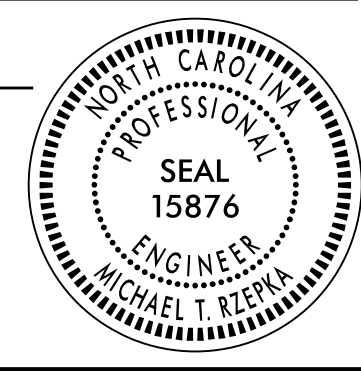

PLOT DRIVER: NCDOT_pdf_color_eng_50.pit
 USER: CHARNDEN
 DATE: 5/4/2022
 FILE: p:\pwhdr\users\01\HDR_US_East_01\Documents\3322\10002133\10279033\6_0_CAD_BITMAP\6.2_WIP\TrafficControl\CPA\R3830_TC_TMP-07.17.dgn

REVISIONS

APPROVED: <i>Michael T. Rzepka</i> DATE: 7/12/2022 SEAL 		PHASE 3 - STEP 1
DOCUMENT NOT CONSIDERED FINAL UNLESS ALL SIGNATURES COMPLETED		