

**EDI MODEL 2018ECL-NC CONFLICT MONITOR**  
**PROGRAMMING DETAIL**  
*(remove jumpers and set switches as shown)*

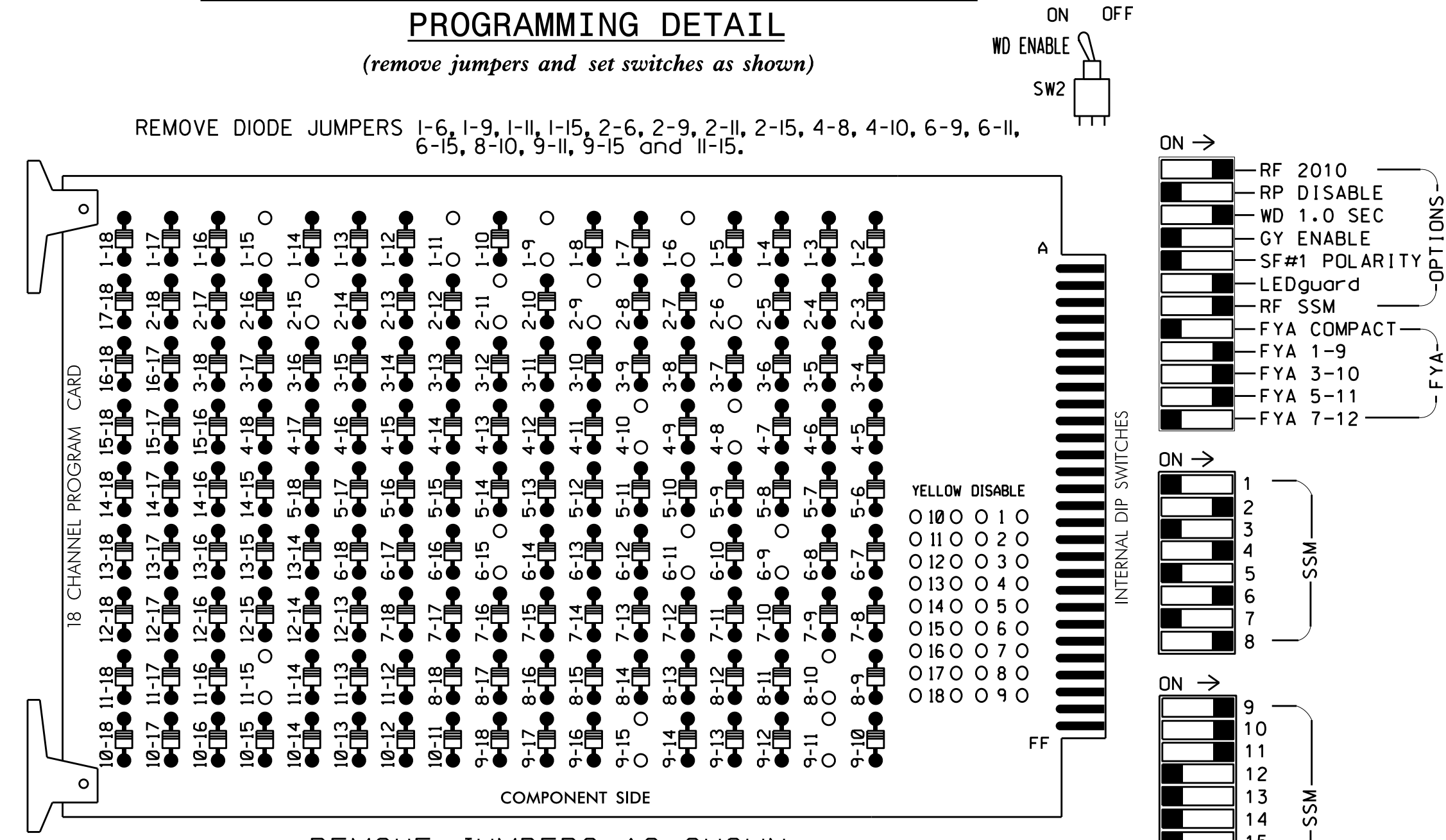

**NOTES**

- To prevent "flash-conflict" problems, insert red flash program blocks for all unused vehicle load switches in the output file. The installer shall verify that signal heads flash in accordance with the Signal Plans.
- Program phases 4 and 8 for Dual Entry.
- Enable Simultaneous Gap-Out for all Phases.
- Program phases 2 and 6 for Variable Initial and Gap Reduction.
- Program phases 2 and 6 for Startup In Green.
- Program phase 6 for Startup Ped Call.
- Program phases 2 and 6 for Yellow Flash, and overlaps 1 and 2 as Wag Overlaps.
- If this signal will be managed by an ATMS software, enable controller and detector logging for all detectors used at this location.
- The cabinet and controller are part of Signal System 10823.

**EQUIPMENT INFORMATION**

CONTROLLER.....2070  
 CABINET.....332 W/ AUX  
 SOFTWARE.....ECONOLITE OASIS  
 CABINET MOUNT.....BASE  
 OUTPUT FILE POSITIONS...18 WITH AUX. OUTPUT FILE  
 LOAD SWITCHES USED.....S1,S2,S5,S8,S9,S11,AUXS1,  
 AUXS2,AUXS4  
 PHASES USED.....1,2,4,6,6PED,8  
 OVERLAP "A".....1+2  
 OVERLAP "B".....4  
 OVERLAP "C".....6  
 OVERLAP "D".....NOT USED

**SIGNAL HEAD HOOK-UP CHART**

LOAD SWITCH NO.	S1	S2	S3	S4	S5	S6	S7	S8	S9	S10	S11	S12	AUX S1	AUX S2	AUX S3	AUX S4	AUX S5	AUX S6
CMU CHANNEL NO.	1	2	13	3	4	14	5	6	15	7	8	16	9	10	17	11	12	18
PHASE	1	2	2PED	3	4	4PED	5	6	6PED	7	8	8PED	OLA	OLB	SPARE	OLC	OLD	SPARE
SIGNAL HEAD NO.	11★	22,23	NU	NU	41,42	NU	NU	61,62	P61, P62	NU	82,83, 84	NU	11★	81★	NU	21★	NU	NU
RED		128			101			134			107							
YELLOW	*	129			102			135			108							
GREEN		130			103			136			109							
RED ARROW													A121	A124		A114		
YELLOW ARROW													A122	A125		A115		
FLASHING YELLOW ARROW													A123	A126		A116		
GREEN ARROW	127																	
Hand																		
Person																		

NU = Not Used  
 \* Denotes install load resistor. See load resistor installation detail this sheet.  
 ★ See pictorial of head wiring in detail this sheet.

**INPUT FILE POSITION LAYOUT**

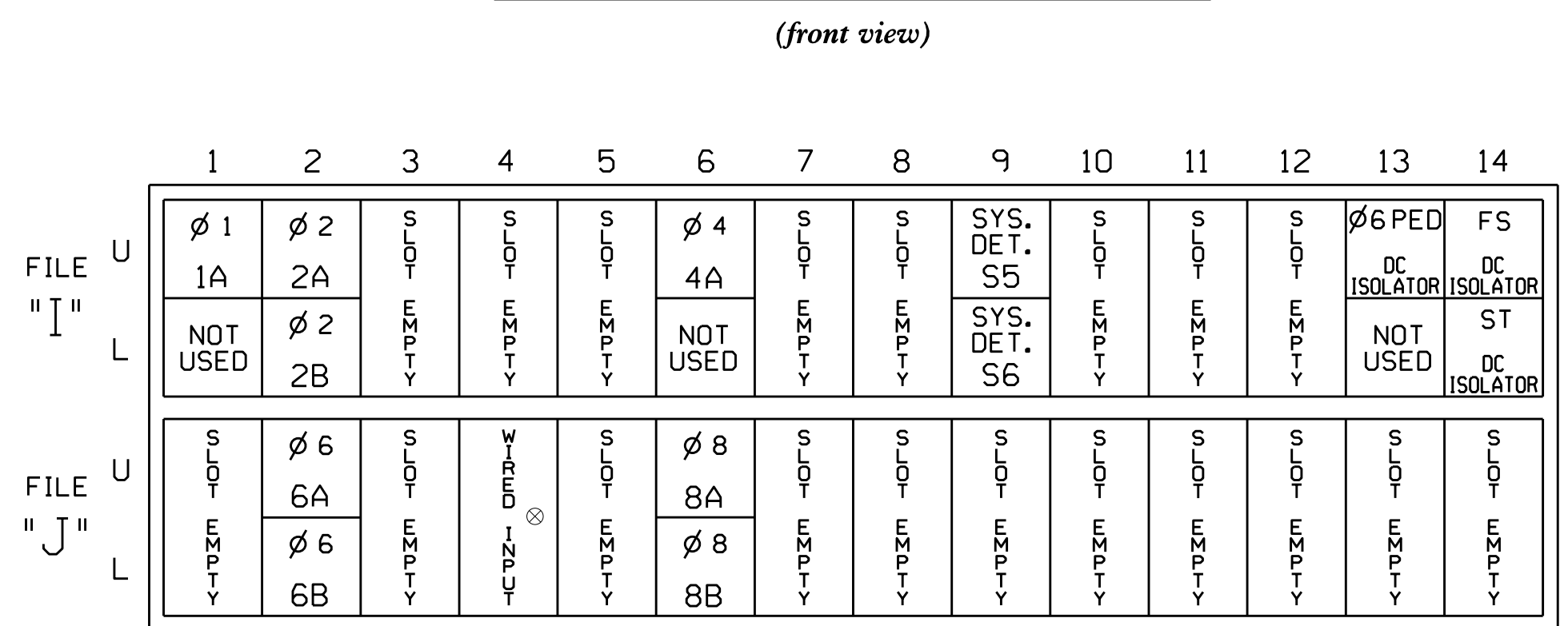

EX.: 1A, 2A, ETC. = LOOP NO.'S  
 FS = FLASH SENSE  
 ST = STOP TIME  
 ⊗ Wired Input - Do not populate slot with detector card

**INPUT FILE CONNECTION & PROGRAMMING CHART**

LOOP NO.	LOOP TERMINAL	INPUT FILE POS.	PIN NO.	INPUT ASSIGNMENT NO.	DETECTOR NO.	NEMA PHASE	CALL	EXTEND	FULL TIME DELAY	STRETCH TIME	DELAY TIME
1A <sup>1</sup>	TB2-1,2	I1U	56	18	1	1	Y	Y			15
	-	J4U	48	10★	26	6	Y	Y	Y		3
2A	TB2-5,6	I2U	39	1	2	2	Y	Y			
2B	TB2-7,8	I2L	43	5	12	2	Y	Y			
2C	TB2-9,10	I3U	63	25	32	2	Y	Y			3
4A	TB4-9,10	I6U	41	3	4	4	Y	Y			10
6A	TB3-5,6	J2U	40	2	6	6	Y	Y			
6B	TB3-7,8	J2L	44	6	16	6	Y	Y			
8A	TB5-9,10	J6U	42	4	8	8	Y	Y			3
8B	TB5-11,12	J6L	46	8	18	8	Y	Y			10
* S5	TB6-9,10	I9U	60	22	11	SYS					
* S6	TB6-11,12	I9L	62	24	13	SYS					
PED PUSH BUTTONS											
P61,P62	TB8-7,9	I13U	68	30	PED 6	6 PED					

- <sup>1</sup>Add jumper from I1-W to J4-W. on rear of input file.  
 ★ See Input Page Assignment programming details on sheet 3.  
 \* System detector only. Remove the vehicle phase assigned to this detector in the default programming.

**LOAD RESISTOR INSTALLATION DETAIL**

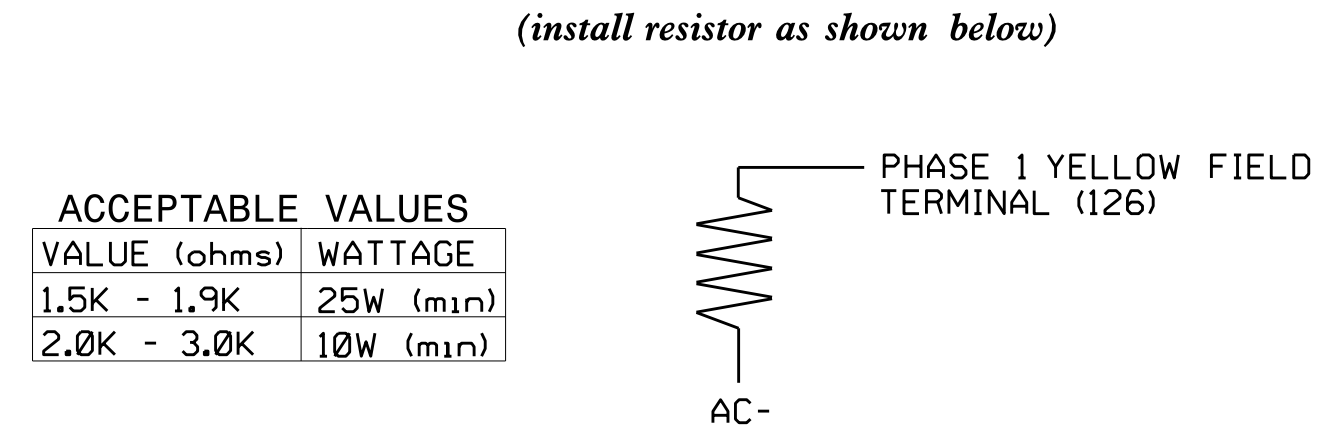

**INPUT FILE POSITION LEGEND:**

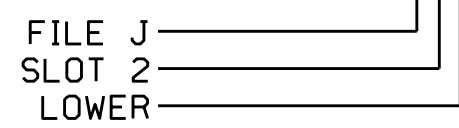

**FYA SIGNAL WIRING DETAIL**

(wire signal heads as shown)

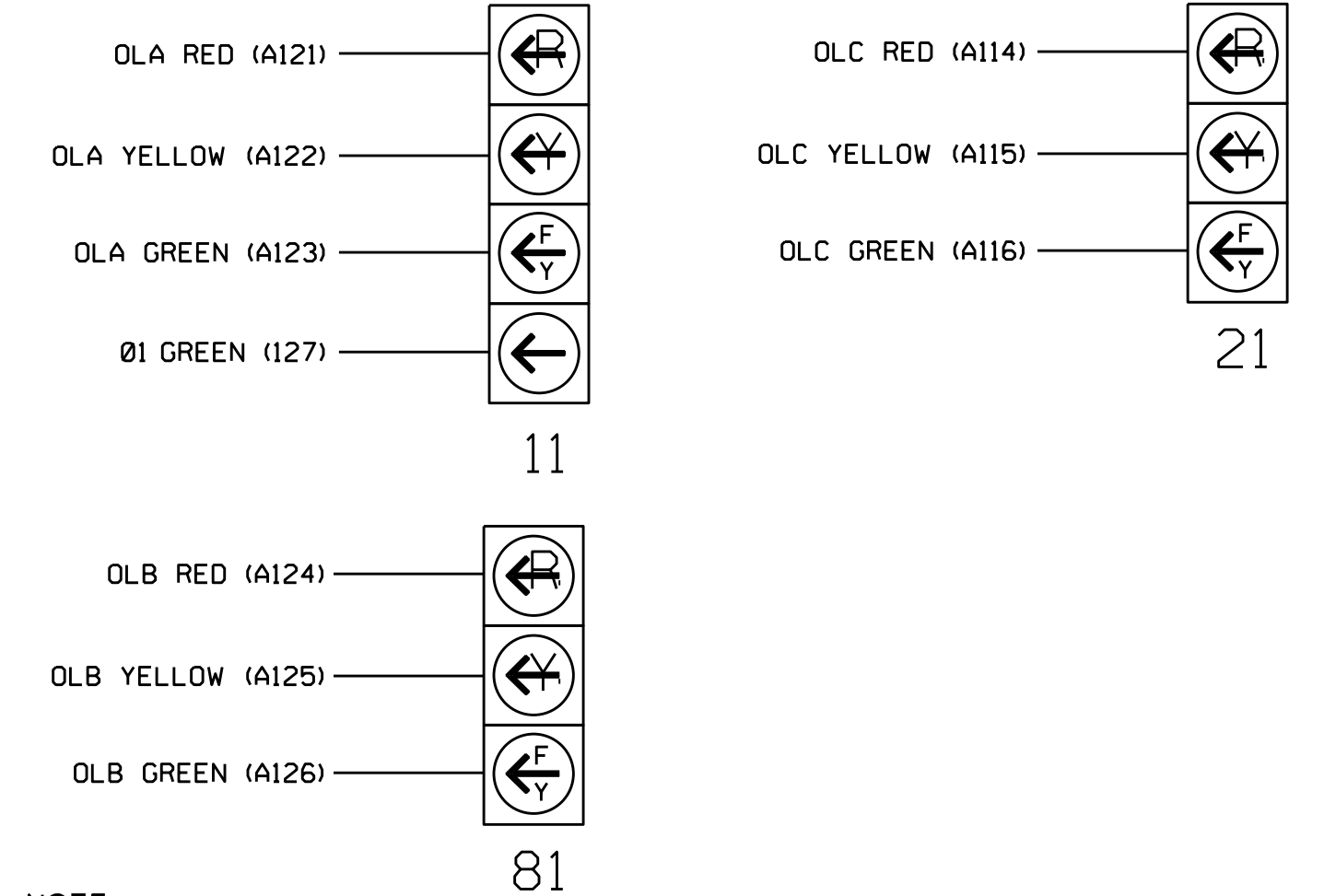

NOTE  
 The sequence display for signal head 11 requires special logic programming. See sheet 2 for programming instructions.

THIS ELECTRICAL DETAIL IS FOR THE SIGNAL DESIGN: 08-0649  
 DESIGNED: MARCH 2022  
 SEALED: 4/20/2022  
 REVISED: N/A

Final Design  
 Electrical Detail - Sheet 1 of 4

DOCUMENT NOT CONSIDERED FINAL UNLESS ALL SIGNATURES COMPLETED

ELECTRICAL AND PROGRAMMING DETAILS FOR:

Prepared for the Offices of:  

 NC 42 (Broadway Road) at SR 1529 (Cox Mill Road) and Bill's Body Shop  
 Division 8 Lee County Sanford

PLAN DATE: April 2022 REVIEWED BY: Todd Joyce  
 PREPARED BY: Keith M. Mims REVIEWED BY: -

REVISIONS	INIT.	DATE

750 N. Greenfield Pkwy, Corner, NC 27529

SEAL  

 Keith M. Mims 04/21/2022  
 DATE

SIG. INVENTORY NO. 08-0649

21-APR-2022 14:25  
 S:\PROJECTS\LINKS\SIGNAL\WORKGROUPS\519 Mon#Projects From Signal Design\Mch1ive Projects\Wlme\In-house\08-0649\080649-sm-le-xxxxxx.dgn  
 kmm/mms