

EDI MODEL 2018ECL-NC CONFLICT MONITOR PROGRAMMING DETAIL

(remove jumpers and set switches as shown)

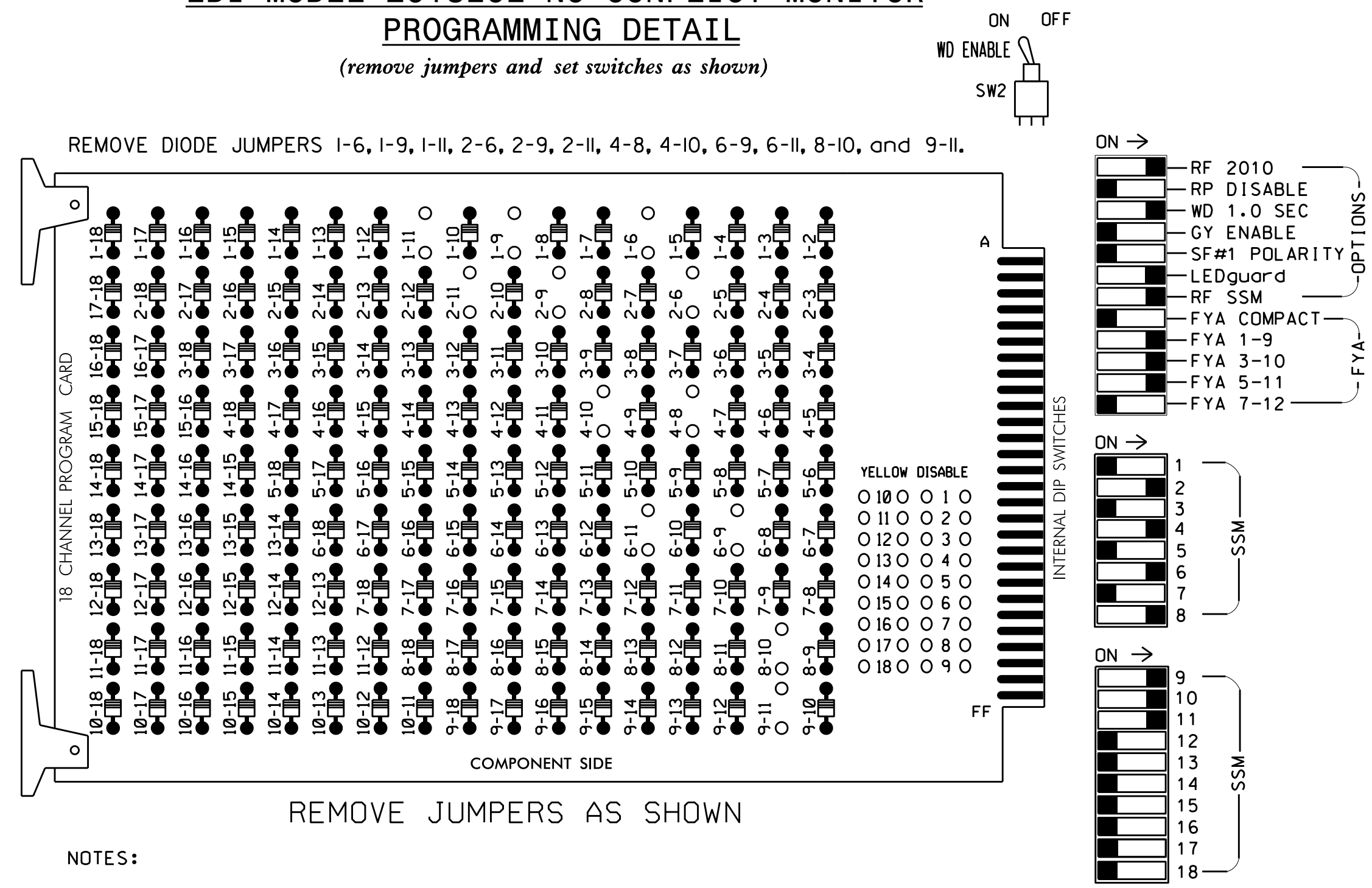

NOTES:

- Card is provided with all diode jumpers in place. Removal of any jumper allows its channels to run concurrently.
- Ensure jumpers SEL2-SEL5 and SEL9 are present on the monitor board.
- Ensure that Red Enable is active at all times during normal operation.
- Connect serial cable from conflict monitor to comm. port 1 of 2070 controller. Ensure conflict monitor communicates with 2070.

NOTES

- To prevent "flash-conflict" problems, insert red flash program blocks for all unused vehicle load switches in the output file. The installer shall verify that signal heads flash in accordance with the Signal Plans.
- Program phases 4 and 8 for Dual Entry.
- Enable Simultaneous Gap-Out for all Phases.
- Program phases 2 and 6 for Variable Initial and Gap Reduction.
- Program phases 2 and 6 for Startup In Green.
- Program phases 2 and 6 for Yellow Flash, and overlaps 1 and 2 as Wag Overlaps.
- If this signal will be managed by an ATMS software, enable controller and detector logging for all detectors used at this location.

EQUIPMENT INFORMATION

CONTROLLER.....2070
 CABINET.....332 W/ AUX
 SOFTWARE.....ECONOLITE OASIS
 CABINET MOUNT.....BASE
 OUTPUT FILE POSITIONS...18 WITH AUX. OUTPUT FILE
 LOAD SWITCHES USED.....S1,S2,S5,S8,S11,AUXS1,AUXS2,AUXS4
 PHASES USED.....1,2,4,6,8
 OVERLAP "A".....1+2
 OVERLAP "B".....4
 OVERLAP "C".....6
 OVERLAP "D".....NOT USED

SIGNAL HEAD HOOK-UP CHART

LOAD SWITCH NO.	S1	S2	S3	S4	S5	S6	S7	S8	S9	S10	S11	S12	AUX S1	AUX S2	AUX S3	AUX S4	AUX S5	AUX S6
CMU CHANNEL NO.	1	2	13	3	4	14	5	6	15	7	8	16	9	10	17	11	12	18
PHASE	1	2	2 PED	3	4	4 PED	5	6	6 PED	7	8	8 PED	OLA	OLB	SPARE	OLC	OLD	SPARE
SIGNAL HEAD NO.	11	22,23	NU	NU	41,42	NU	NU	61,62	NU	NU	82,83 84	NU	11	81	NU	21	NU	NU
RED		128			101			134			107							
YELLOW	*	129			102			135			108							
GREEN		130			103			136			109							
RED ARROW													A121	A124				A114
YELLOW ARROW													A122	A125				A115
FLASHING YELLOW ARROW													A123	A126				A116
GREEN ARROW	127																	

NU = Not Used
 * Denotes install load resistor. See load resistor installation detail this sheet.
 ★ See pictorial of head wiring in detail this sheet.

FYA SIGNAL WIRING DETAIL

(wire signal heads as shown)

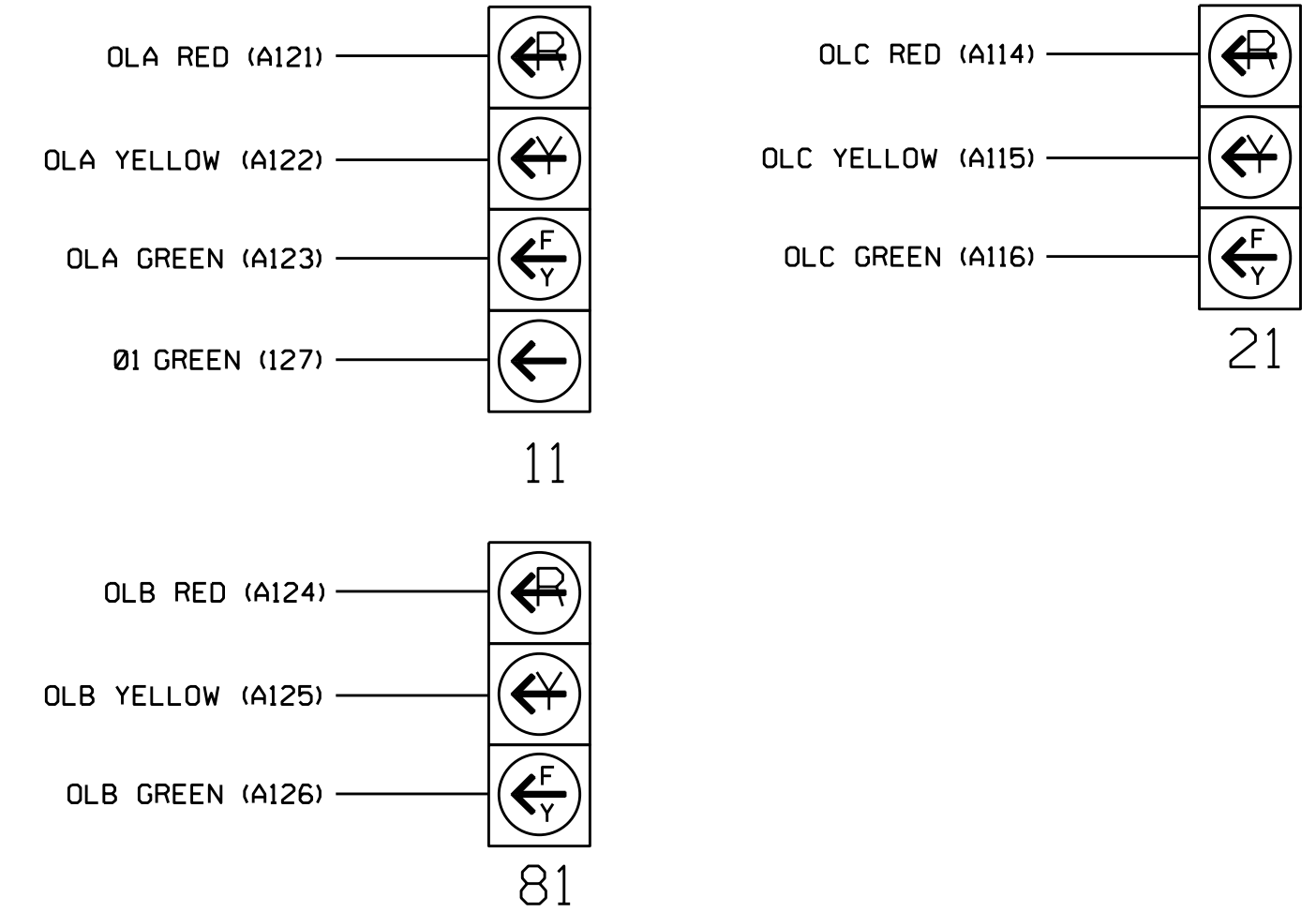

NOTE

The sequence display for signal head 11 requires special logic programming. See sheet 2 for programming instructions.

INPUT FILE POSITION LAYOUT

(front view)

FILE	U	1	2	3	4	5	6	7	8	9	10	11	12	13	14	
"I"	U	∅ 1	-ORS	-ORS	-ORS	-ORS	-ORS	-ORS	-ORS	-ORS	-ORS	-ORS	-ORS	-ORS	-ORS	FS
	L	1A	-ORS	-ORS	-ORS	-ORS	-ORS	-ORS	-ORS	-ORS	-ORS	-ORS	-ORS	-ORS	-ORS	DC ISOLATOR
"J"	U	NOT USED	-ORS	-ORS	-ORS	-ORS	-ORS	-ORS	-ORS	-ORS	-ORS	-ORS	-ORS	-ORS	-ORS	ST
	L	-ORS	-ORS	-ORS	-ORS	-ORS	-ORS	-ORS	-ORS	-ORS	-ORS	-ORS	-ORS	-ORS	-ORS	DC ISOLATOR

EX.: 1A, 2A, ETC. = LOOP NO.'S
 FS = FLASH SENSE
 ST = STOP TIME
 ⊗ Wired Input - Do not populate slot with detector card

INPUT FILE CONNECTION & PROGRAMMING CHART

LOOP NO.	LOOP TERMINAL	INPUT FILE POS.	PIN NO.	INPUT ASSIGNMENT NO.	DETECTOR NO.	NEMA PHASE	CALL	EXTEND	FULL TIME DELAY	STRETCH TIME	DELAY TIME
1A ¹	TB2-1,2	I1U	56	18	1	1	Y	Y			15
	-	J4U	48	10★	26	6	Y	Y	Y		3
	-	I1U	56	18★	51	1	Y	Y			3

¹Add jumper from I1-W to J4-W, on rear of input file.
 ★ See Input Page Assignment programming details on sheet 3.

INPUT FILE POSITION LEGEND: J2L

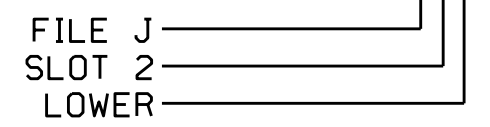

DETECTOR NOTES

- For all loops install a video detection system for vehicle detection. Perform installation according to manufacturer's directions and NCDOT engineer-approved mounting locations to accomplish the detection schemes shown on the Signal Design Plans.
- For loop 1A, detector card placement and slot reserved for wired input are typical for a NCDOT installation. Input associated with this slot are compatible with time of day instructions located on sheet 3 of this electrical detail.

LOAD RESISTOR INSTALLATION DETAIL

(install resistor as shown below)

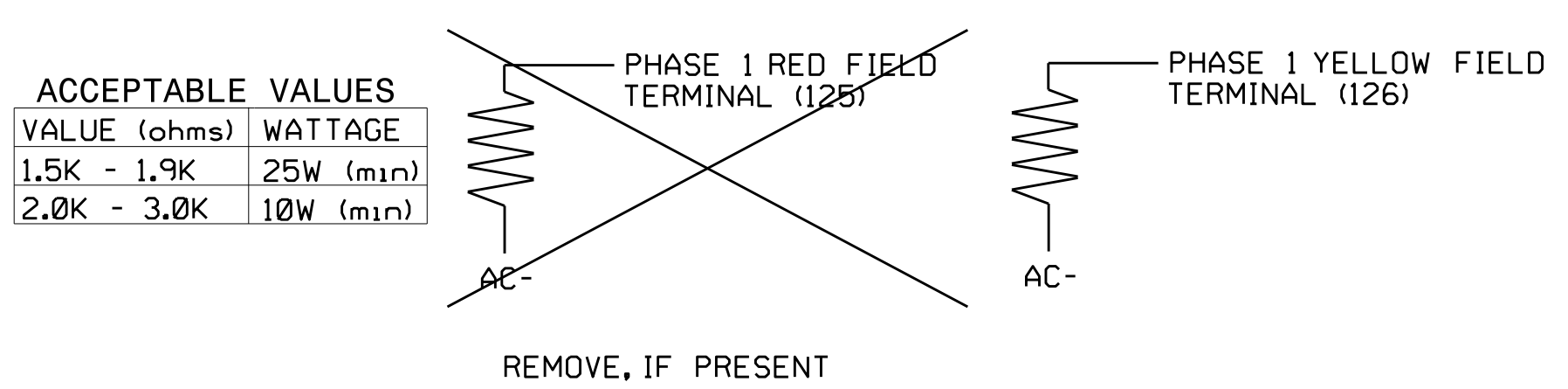

THIS ELECTRICAL DETAIL IS FOR THE SIGNAL DESIGN: 08-0649T2
 DESIGNED: JANUARY 2022
 SEALED: 4/20/2022
 REVISED: N/A

Temporary Design 2 - (TMP Phase I)
 Electrical Detail - Sheet 1 of 4

DOCUMENT NOT CONSIDERED FINAL UNLESS ALL SIGNATURES COMPLETED

Electrical and Programming Details for:
 NC 42 (Broadway Road) at SR 1529 (Cox Mill Road) and Bill's Body Shop
 Division 8 Lee County Sanford
 PLAN DATE: April 2022 REVIEWED BY: Todd Joyce
 PREPARED BY: Keith M. Mims REVIEWED BY: -
 REVISIONS: INIT. DATE
 SEAL: NORTH CAROLINA PROFESSIONAL ENGINEER KEITH M. MIMS 036880
 Signature: Keith M. Mims 04/21/2022
 SIG. INVENTORY NO. 08-0649T2

21-APR-2022 13:58 S:\TAS\UMTS\Sig\018\Workgroups\4519\Mon\Projects From Signal Design\Mch1ive\Project\mim\house\08-0649\080649-sm-le-12-xxxxx.dgn km/mms