

UTILITIES BY OTHERS

ALL PROPOSED UTILITY WORK SHOWN ON THIS SHEET WILL BE DONE BY OTHERS. NO PAYMENT WILL BE MADE TO THE CONTRACTOR FOR PROPOSED UTILITY WORK SHOWN ON THIS SHEET.

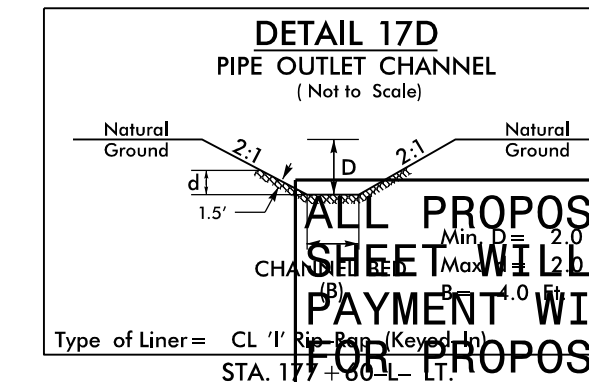
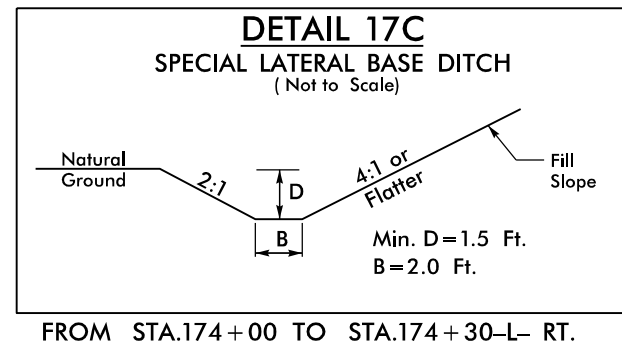
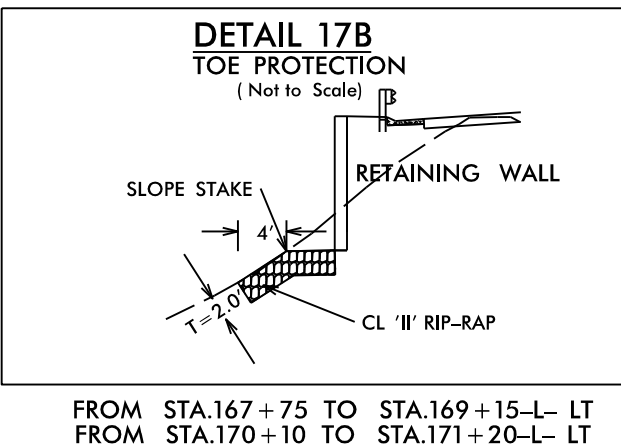
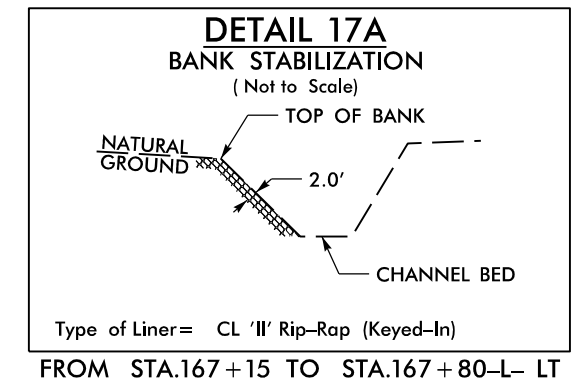
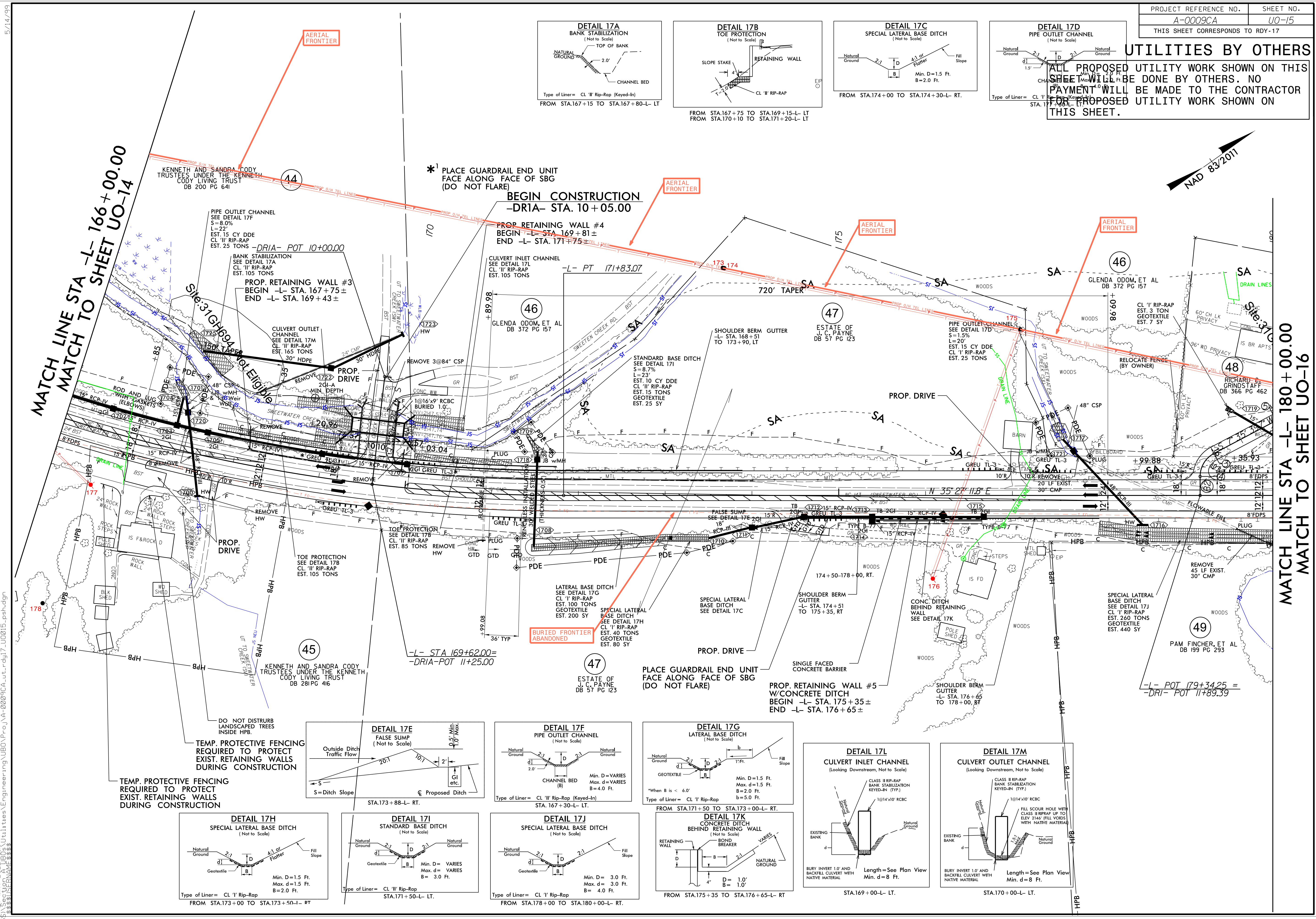

MATCH LINE STA -L- 166+00.00
MATCH TO SHEET UO-14

MATCH LINE STA -L- 180+00.00
MATCH TO SHEET UO-16

*1 PLACE GUARDRAIL END UNIT
FACE ALONG FACE OF SBG
(DO NOT FLARE)

BEGIN CONSTRUCTION
-DRIA- STA. 10+05.00

PROP. RETAINING WALL #4
BEGIN -L- STA. 169+81±
END -L- STA. 171+75±

PIPE OUTLET CHANNEL
SEE DETAIL 17F
S=8.0%
L=22'
EST. 15 CY DDE
CL '1' RIP-RAP
EST. 25 TONS

BANK STABILIZATION
SEE DETAIL 17A
CL '1' RIP-RAP
EST. 105 TONS

PROP. RETAINING WALL #3
BEGIN -L- STA. 167+75±
END -L- STA. 169+43±

CULVERT INLET CHANNEL
SEE DETAIL 17L
CL '1' RIP-RAP
EST. 105 TONS

GLENDA ODOM, ET AL
DB 372 PG 157

STANDARD BASE DITCH
SEE DETAIL 17I
S=8.7%
L=23'
EST. 10 CY DDE
CL '1' RIP-RAP
EST. 15 TONS
GEOTEXTILE
EST. 25 SY

ESTATE OF
J. C. PAYNE
DB 57 PG 123

PIPE OUTLET CHANNEL
SEE DETAIL 17D
S=1.5%
L=20'
EST. 15 CY DDE
CL '1' RIP-RAP
EST. 25 TONS

GLENDA ODOM, ET AL
DB 372 PG 157

CL '1' RIP-RAP
EST. 3 TON
GEOTEXTILE
EST. 7 SY

RELOCATE FENCE
(BY OWNER)

RICHARD C.
GRINDSTAFF
DB 366 PG 462

PROP. DRIVE

REMOVE 3@84" CSP

REMOVE 2@16" RBCB
BURIED 1.0'

REMOVE 1@16" RBCB
BURIED 1.0'

REMOVE 1@16" RBCB
BURIED 1.0'

REMOVE 1@16" RBCB
BURIED 1.0'

REMOVE 1@16" RBCB
BURIED 1.0'

REMOVE 1@16" RBCB
BURIED 1.0'

REMOVE 1@16" RBCB
BURIED 1.0'

REMOVE 1@16" RBCB
BURIED 1.0'

REMOVE 1@16" RBCB
BURIED 1.0'

REMOVE 1@16" RBCB
BURIED 1.0'

REMOVE 1@16" RBCB
BURIED 1.0'

REMOVE 1@16" RBCB
BURIED 1.0'

REMOVE 1@16" RBCB
BURIED 1.0'

REMOVE 1@16" RBCB
BURIED 1.0'

REMOVE 1@16" RBCB
BURIED 1.0'

REMOVE 1@16" RBCB
BURIED 1.0'

REMOVE 1@16" RBCB
BURIED 1.0'

REMOVE 1@16" RBCB
BURIED 1.0'

REMOVE 1@16" RBCB
BURIED 1.0'

REMOVE 1@16" RBCB
BURIED 1.0'

REMOVE 1@16" RBCB
BURIED 1.0'

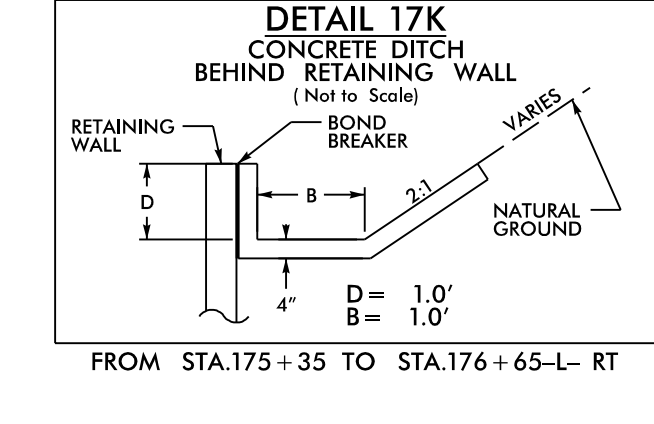
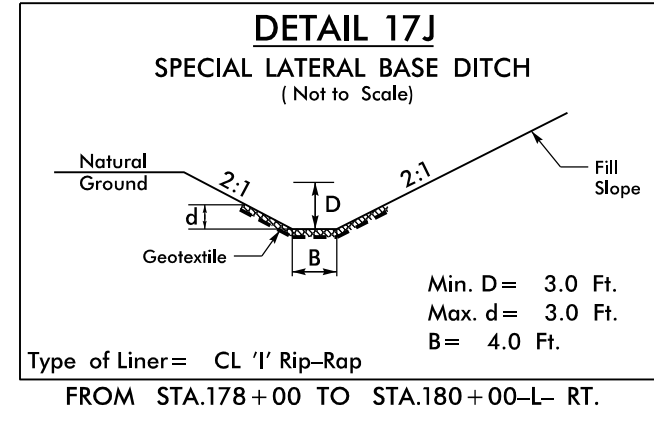
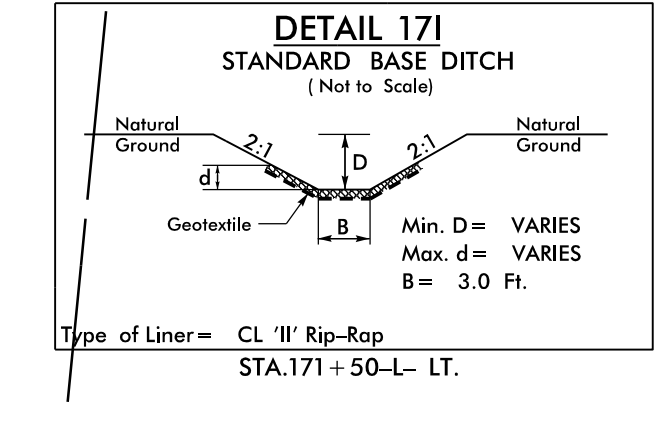
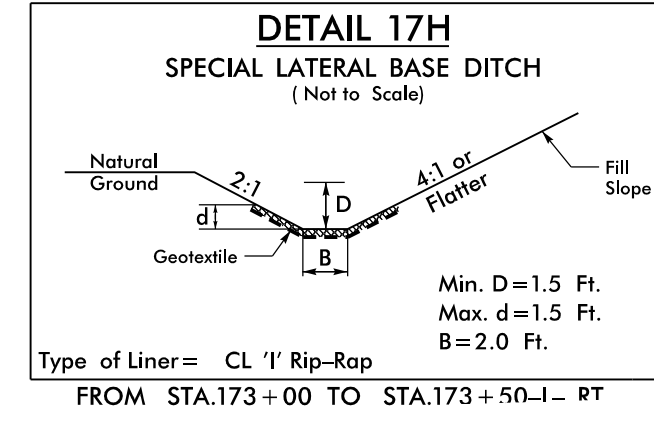
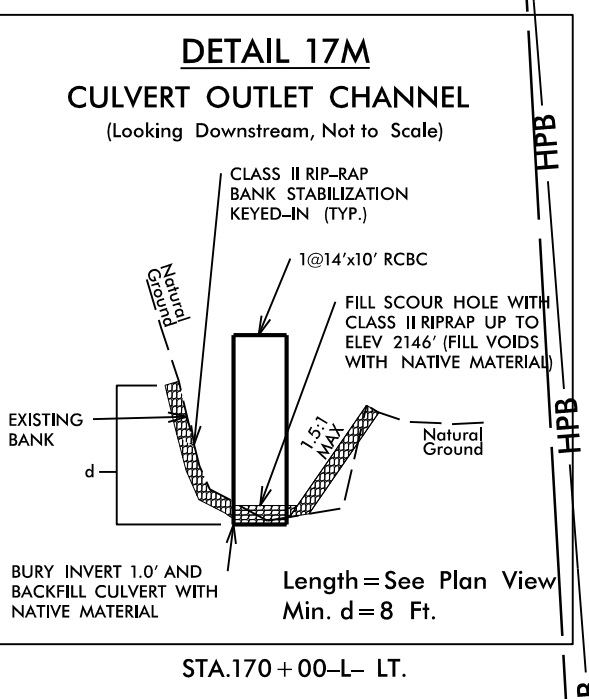
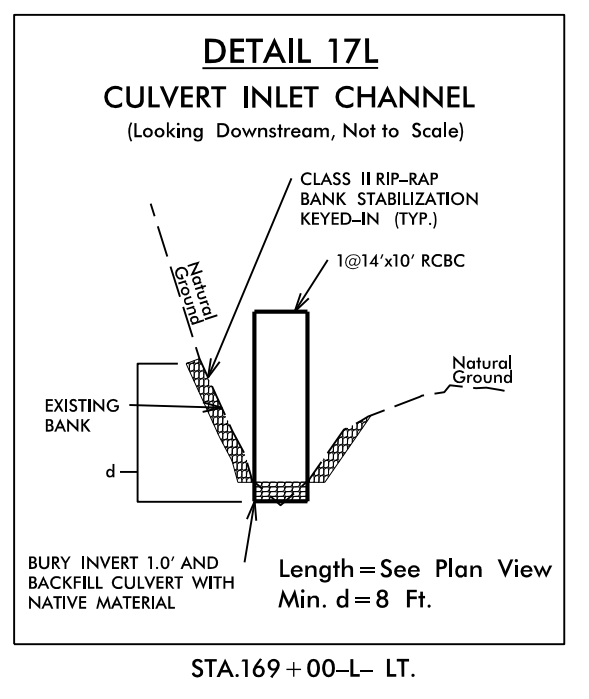
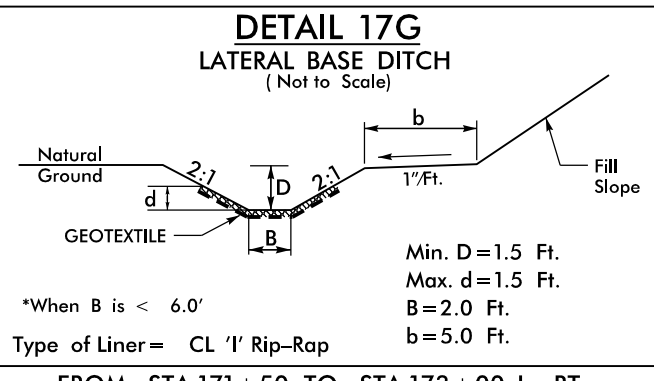
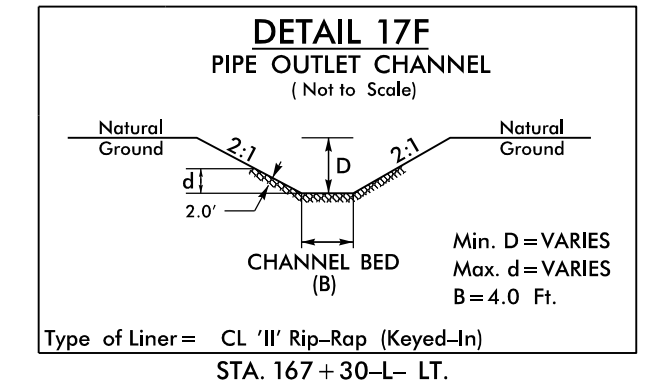
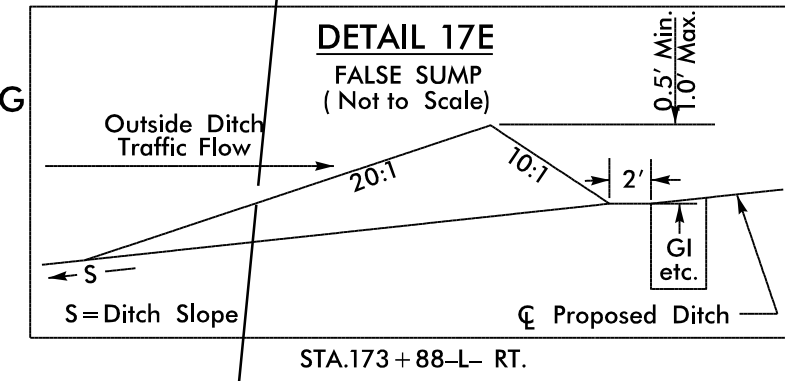

TEMP. PROTECTIVE FENCING
REQUIRED TO PROTECT
EXIST. RETAINING WALLS
DURING CONSTRUCTION

TEMP. PROTECTIVE FENCING
REQUIRED TO PROTECT
EXIST. RETAINING WALLS
DURING CONSTRUCTION

DO NOT DISTURB
LANDSCAPED TREES
INSIDE HPB.

27 MAY 2022 16:40 Utilities\Engineering\UBO\Proj\A-0009CA_ut_r.dwg 17:00015_psh.dgn
90 (TGS)\Sector\Utilities\Engineering\UBO\Proj\A-0009CA_ut_r.dwg 17:00015_psh.dgn