

UTILITIES BY OTHERS

ALL PROPOSED UTILITY WORK SHOWN ON THIS SHEET WILL BE DONE BY OTHERS. NO PAYMENT WILL BE MADE TO THE CONTRACTOR FOR PROPOSED UTILITY WORK SHOWN ON THIS SHEET.

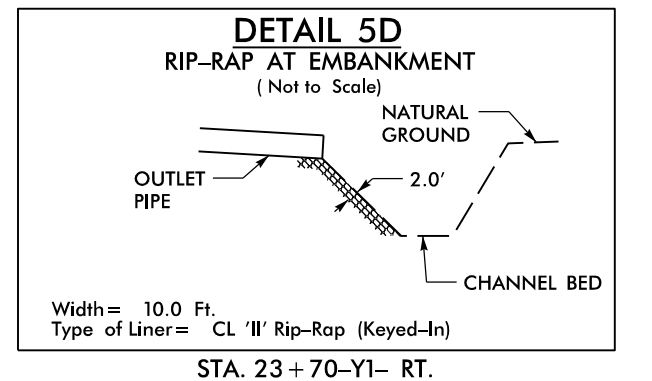

8	EDDIE R. BROOMS, JR. DB 335 PG 807
8A	CLARA BELLE SHULER HEIRS DB 52 PG 435 DB 53 PG 42

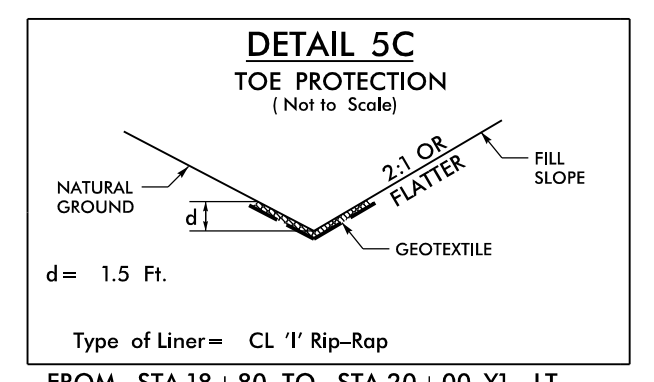
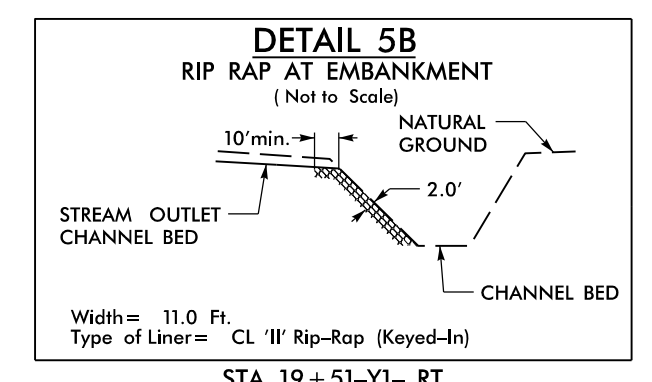
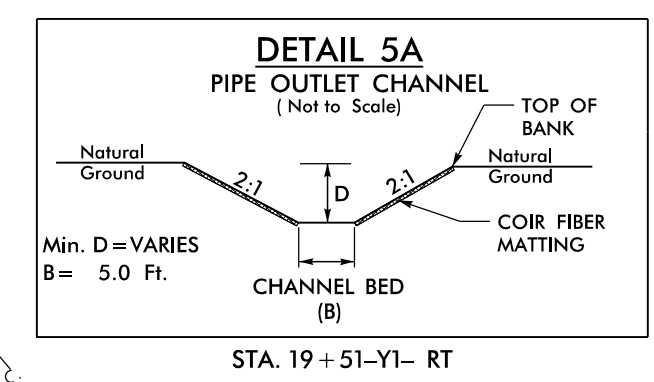
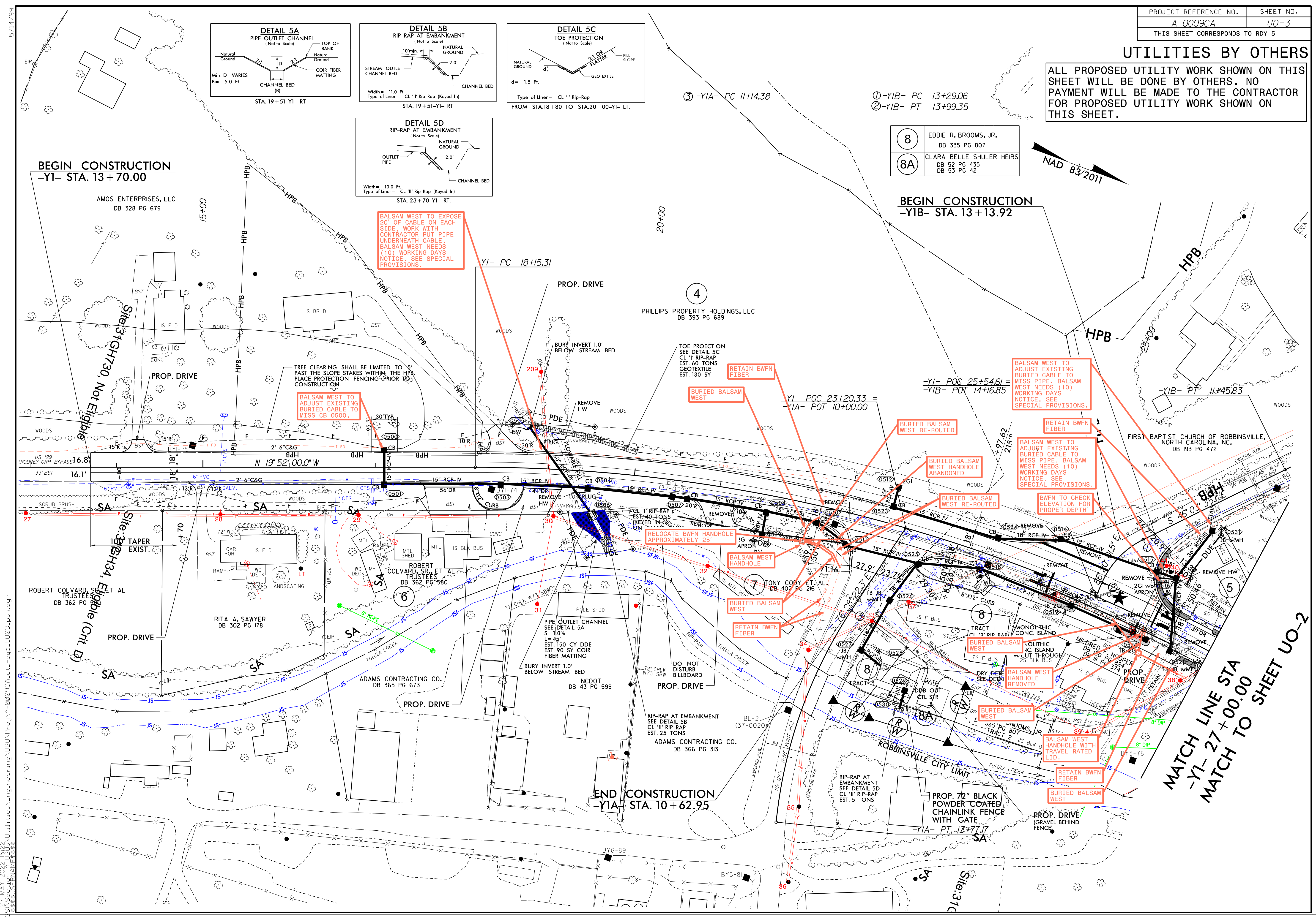
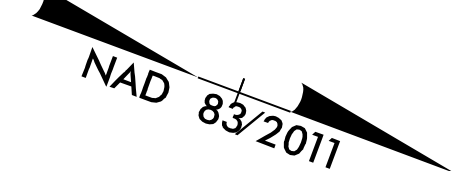

BEGIN CONSTRUCTION
-Y1- STA. 13+70.00

BEGIN CONSTRUCTION
-Y1B- STA. 13+13.92

END CONSTRUCTION
-Y1A- STA. 10+62.95

MATCH LINE STA
-Y1- 27+00.00
MATCH TO SHEET U0-2

27-MAY-2022 15:22 Utilities\Engineering\UBD\Pro\A-0009CA.ut_rdy5_U003_psh.dgn
 2022-05-27 15:22 Utilities\Engineering\UBD\Pro\A-0009CA.ut_rdy5_U003_psh.dgn