

8.17.799  
REVISONS  
5/20/2022  
C:\Projects\Roadway\Proj\A-0009CA\_Plan  
Sheets\A-0009CA\_Rdy\_psh\_17.dgn  
1/1/2022

MATCH LINE STA -L- 166+00.00  
MATCH TO SHEET NO. 16

MATCH LINE STA -L- 180+00.00  
MATCH TO SHEET NO. 18

**-L- CURVE DATA**  
 PI Sta 166+10.36  
 $\Delta = 35^\circ 44' 58.6" (LT)$   
 $D = 3^\circ 00' 56.0"$   
 $L = 1,185.50'$   
 $T = 612.76'$   
 $R = 1,900.00'$   
 $SE = 0.07$   
 $DS = 60 MPH$

**-DRI- CURVE DATA**  
 PI Sta 10+41.97  
 $\Delta = 48^\circ 49' 47.4" (RT)$   
 $D = 190^\circ 59' 09.4"$   
 $L = 25.57'$   
 $T = 13.62'$   
 $R = 30.00'$   
 ③ -DRI- PC 11+34.96  
 ④ -DRI- PT 11+67.50

PI Sta 11+53.03  
 $\Delta = 62^\circ 08' 27.9" (LT)$   
 $D = 190^\circ 59' 09.4"$   
 $L = 32.54'$   
 $T = 18.08'$   
 $R = 30.00'$

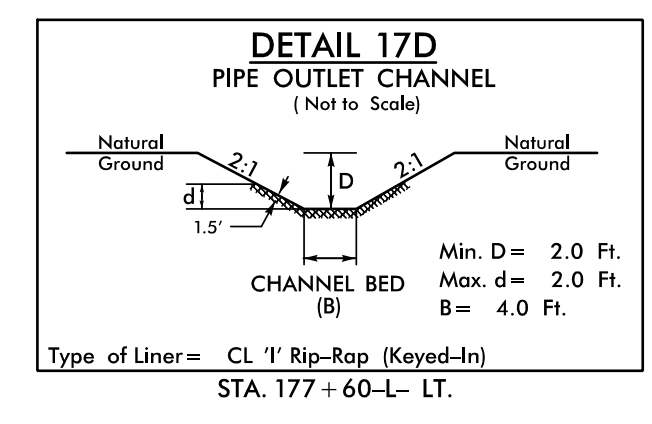
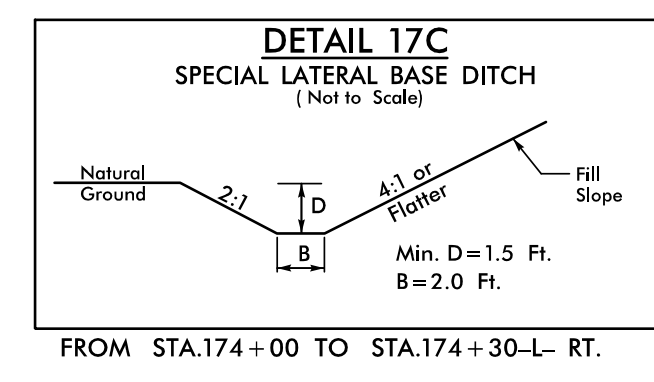
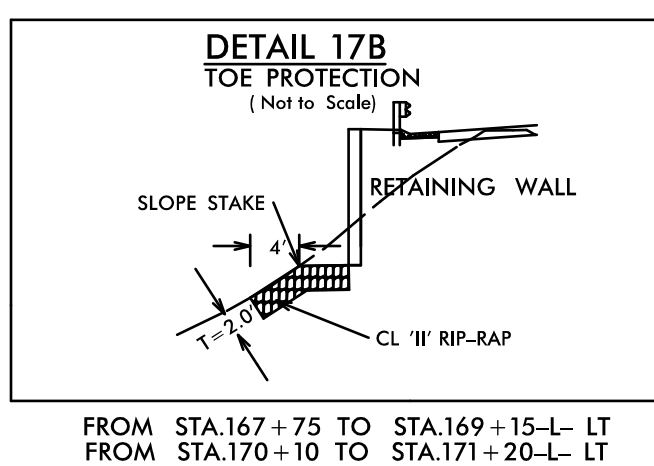
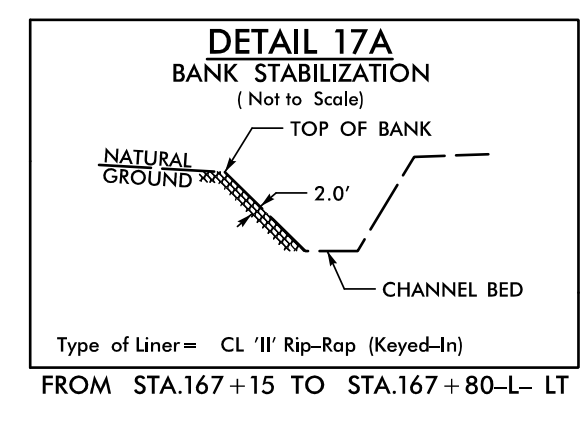

NOTE:  
ALL DRIVEWAYS ARE TO BE ASPHALT UNLESS OTHERWISE NOTED.  
END LOCATION OF DRIVEWAY ON PLANS REPRESENTS TIE-IN PER CROSS-SECTIONS, THE CONTRACTOR SHALL EXTEND THE DRIVES AND PAVE UP TO THE RIGHT OF WAY LINE FROM ROW POINT ON MATCH DRIVEWAY IN KIND, UNLESS OTHERWISE NOTED.

FOR CULVERT PLANS, SEE SHEET C7-1 THRU C7-8

NOTE:  
PRIOR TO COMMENCING WORK ON ANY TRENCHLESS INSTALLATION, PROVIDE A DESIGN FOR THE TRENCHLESS INSTALLATION CERTIFIED BY AN ENGINEER LICENSED BY THE STATE OF NORTH CAROLINA, AS REQUIRED BY SUBARTICLE 1550-3(B) OF THE STANDARD SPECIFICATIONS.

\* PLACE GUARDRAIL END UNIT FACE ALONG FACE OF SBG (DO NOT FLARE)

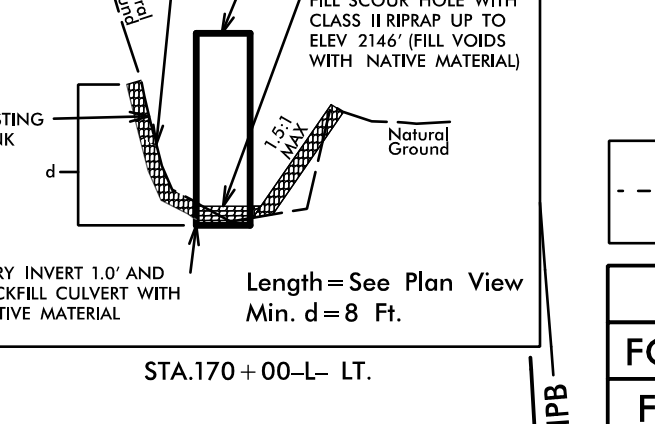
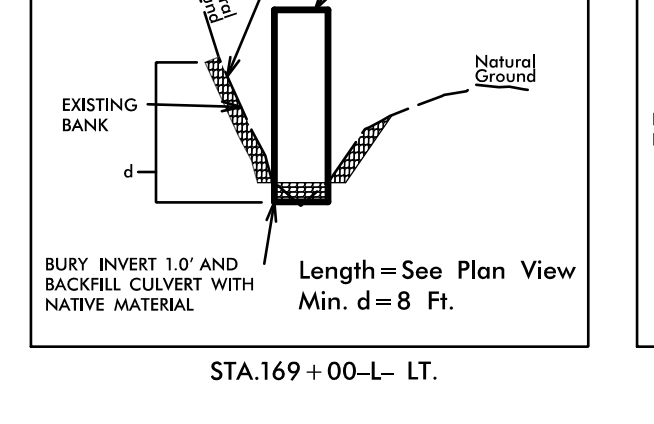
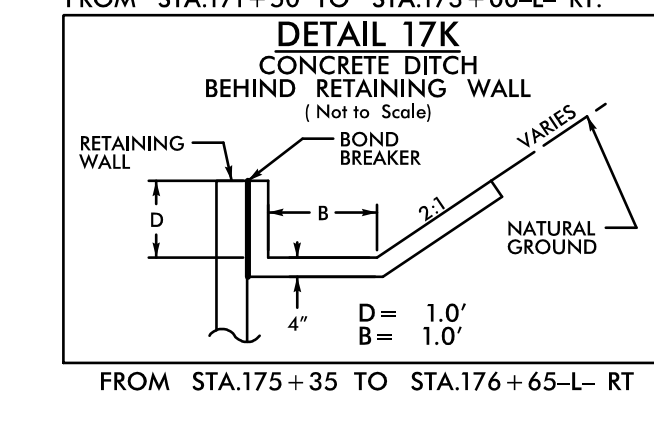
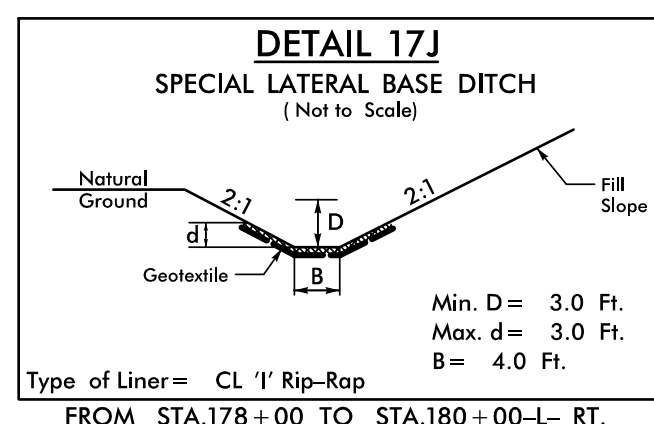
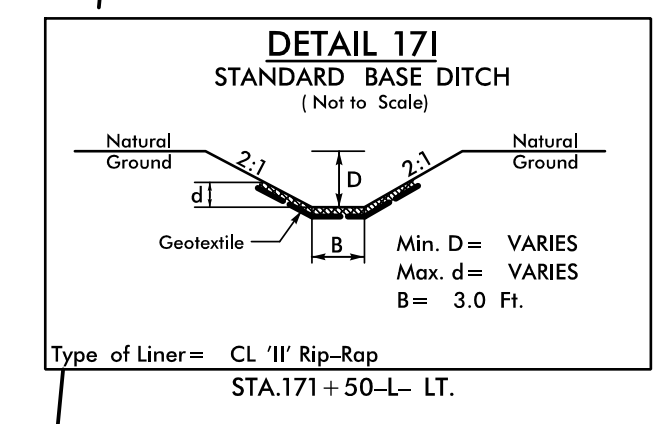
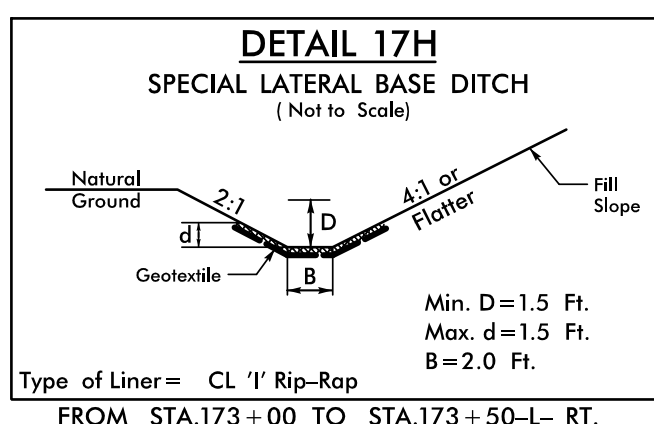
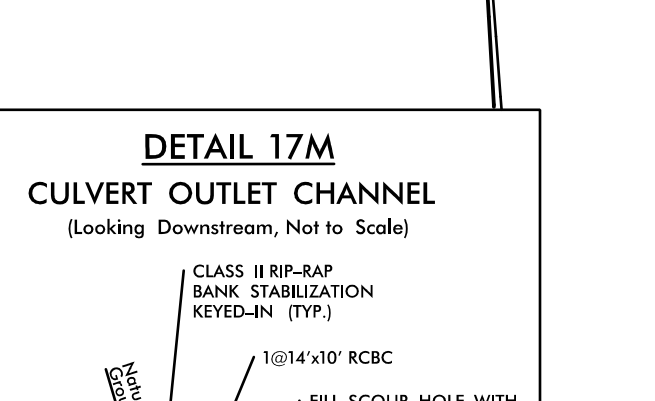
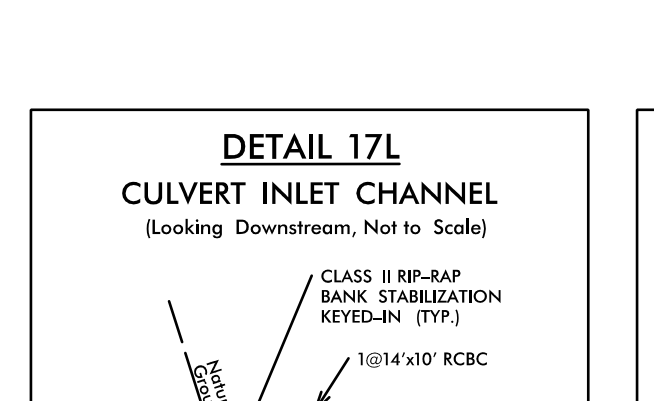
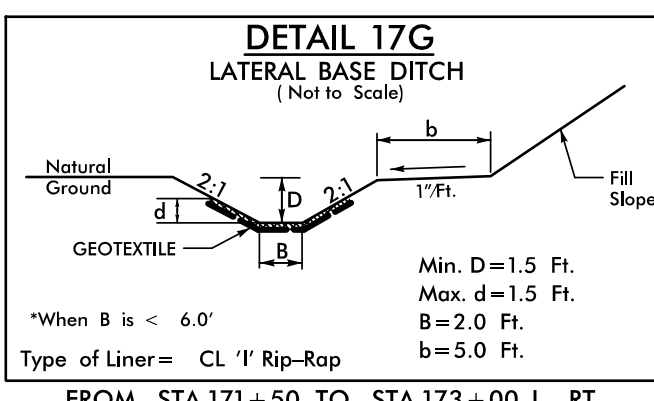
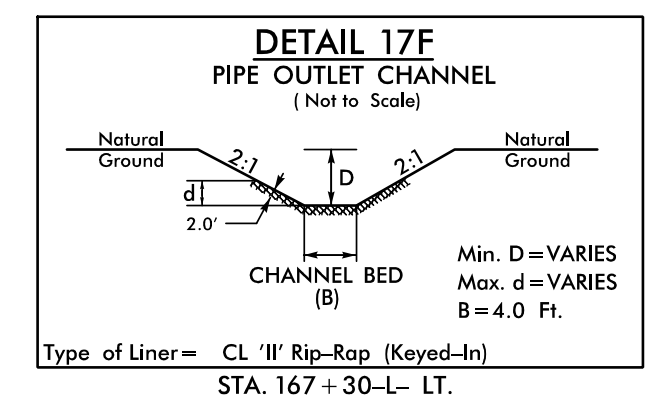
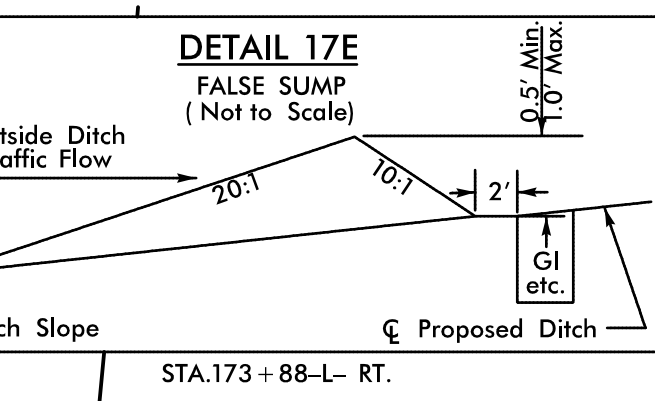
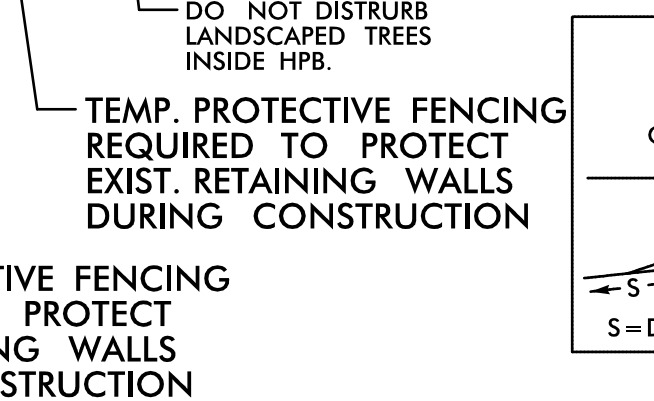
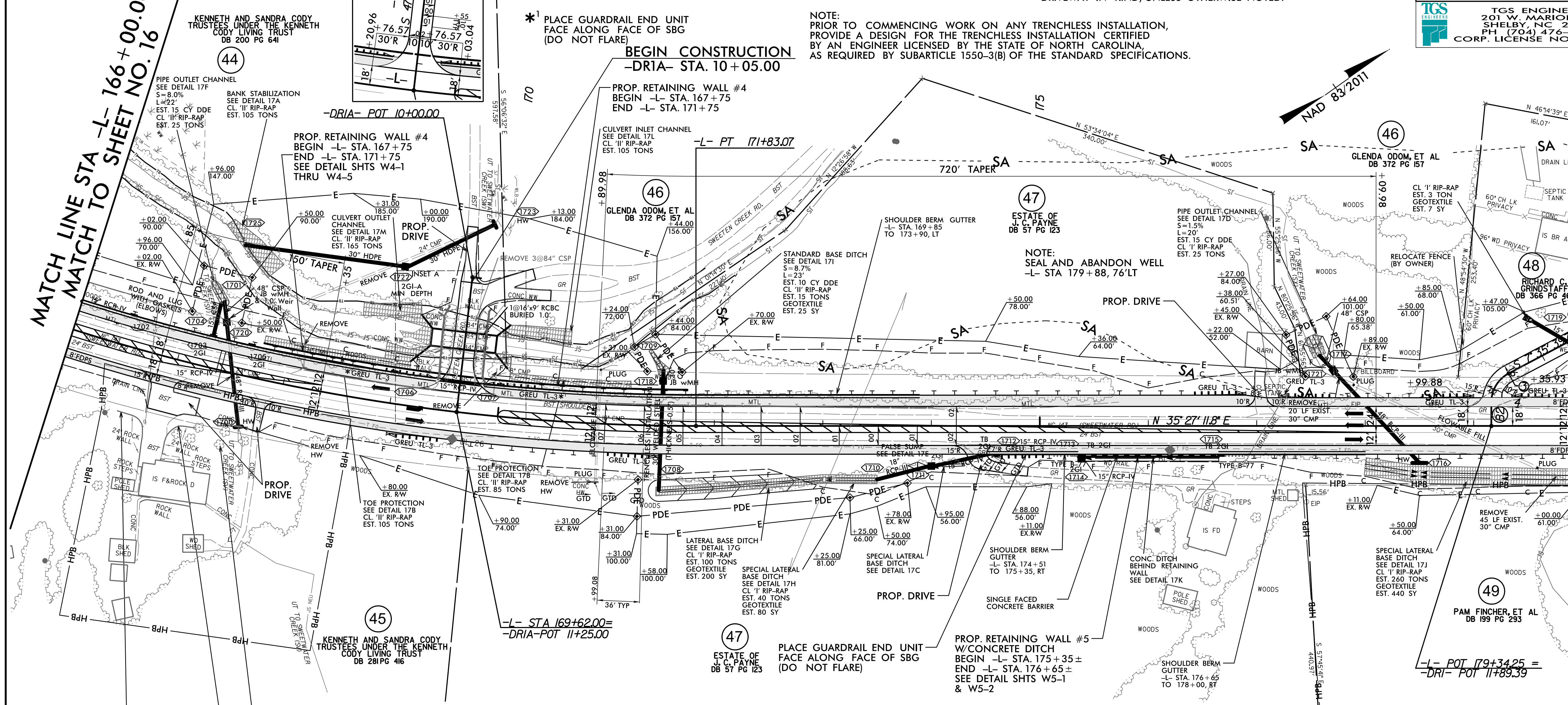

--- SA --- ELIGIBLE AND UNASSESSED SITES

FOR -L- PROFILE, SEE SHEET NO. 26  
 FOR -DRIA- PROFILE, SEE SHEET NO. 28  
 FOR -DRI- PROFILE, SEE SHEET NO. 28

PROJECT REFERENCE NO. A-0009CA	SHEET NO. 17
ROADWAY DESIGN ENGINEER TERRY J. HENNECK 35018 5/31/2022	HYDRAULICS ENGINEER TERRY J. HENNECK 044158 5/31/2022
DOCUMENT NOT CONSIDERED FINAL UNLESS ALL SIGNATURES COMPLETED	
TGS ENGINEERS 201 W. MARION ST SHELBY, NC 28150 PH (704) 476-0003 CORP. LICENSE NO.: C-0275	