

DRY DETENTION BASIN#1

SHEET 4 OF 4

PROJECT REFERENCE NO. A-0009CA	SHEET NO. 2D-8
RW SHEET NO.	
HYDRAULICS ENGINEER	
DOCUMENT NOT CONSIDERED FINAL UNLESS ALL SIGNATURES COMPLETED	

REBAR & ORIFICE TRASH RACKS (N.T.S.)

RISER TRASH RACK NOTES:

1. ALL JOINTS SHALL BE FULLY WELDED AROUND JOINT WITH A MINIMUM OF A 1/4" BEAD.
2. IF BOLTS ARE ANCHORED IN CONCRETE, FOLLOW STD. DWG. 862.03 AND 862.04 FOR ANCHORING PROCEDURE.
3. EYEBOLT FOR CHAIN CLOSURE SHALL BE INSTALLED BY THE SAME METHOD AS THE HINGE PLATE BOLTS.
4. RACK AND HARDWARE SHALL BE ALUMINUM OR REBAR AND GALVANIZED IN ACCORDANCE WITH ASTM A-153.

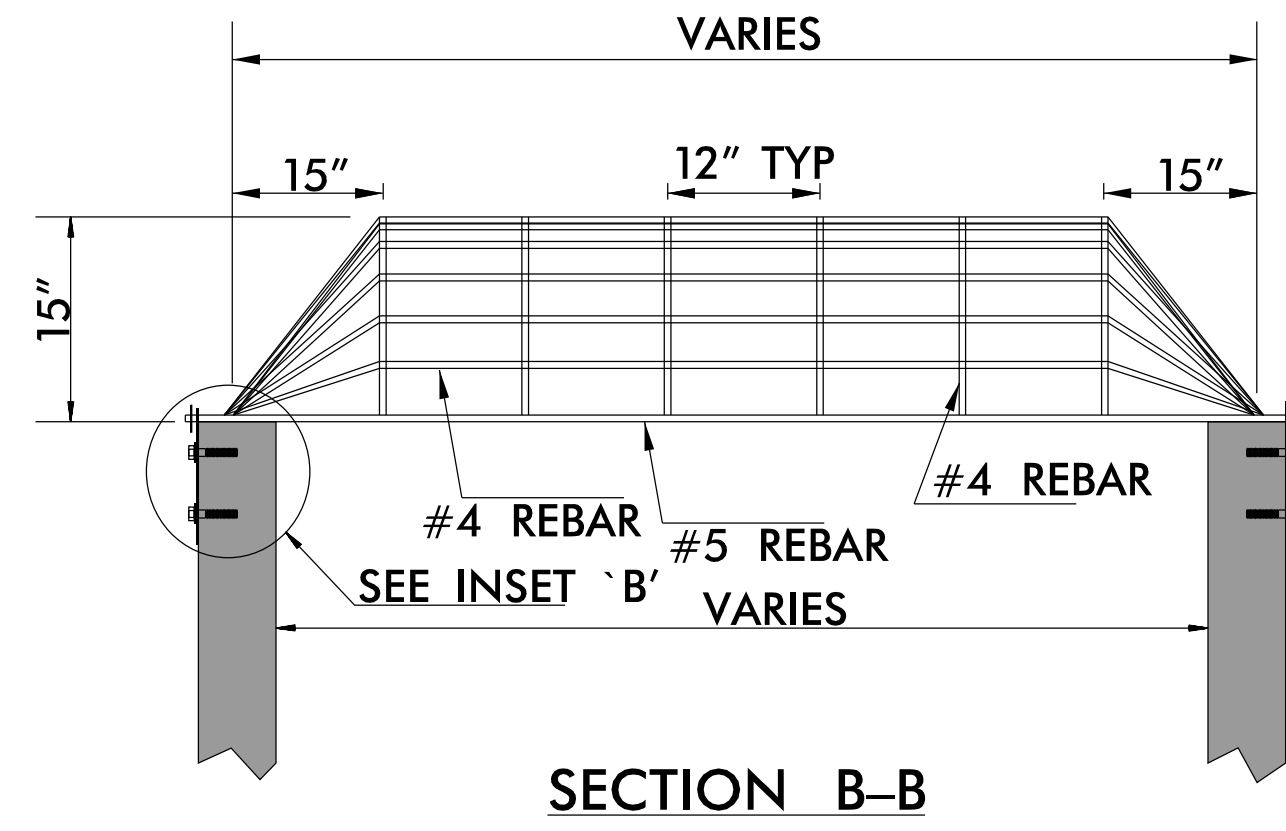
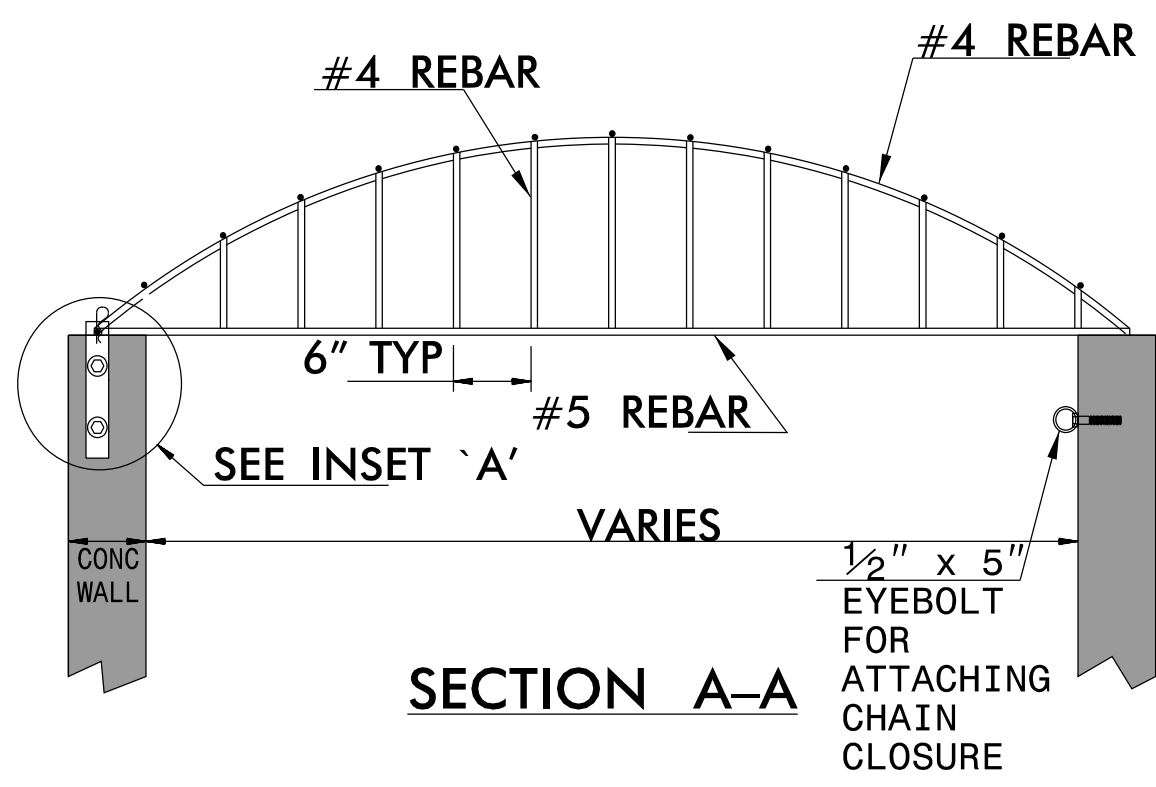
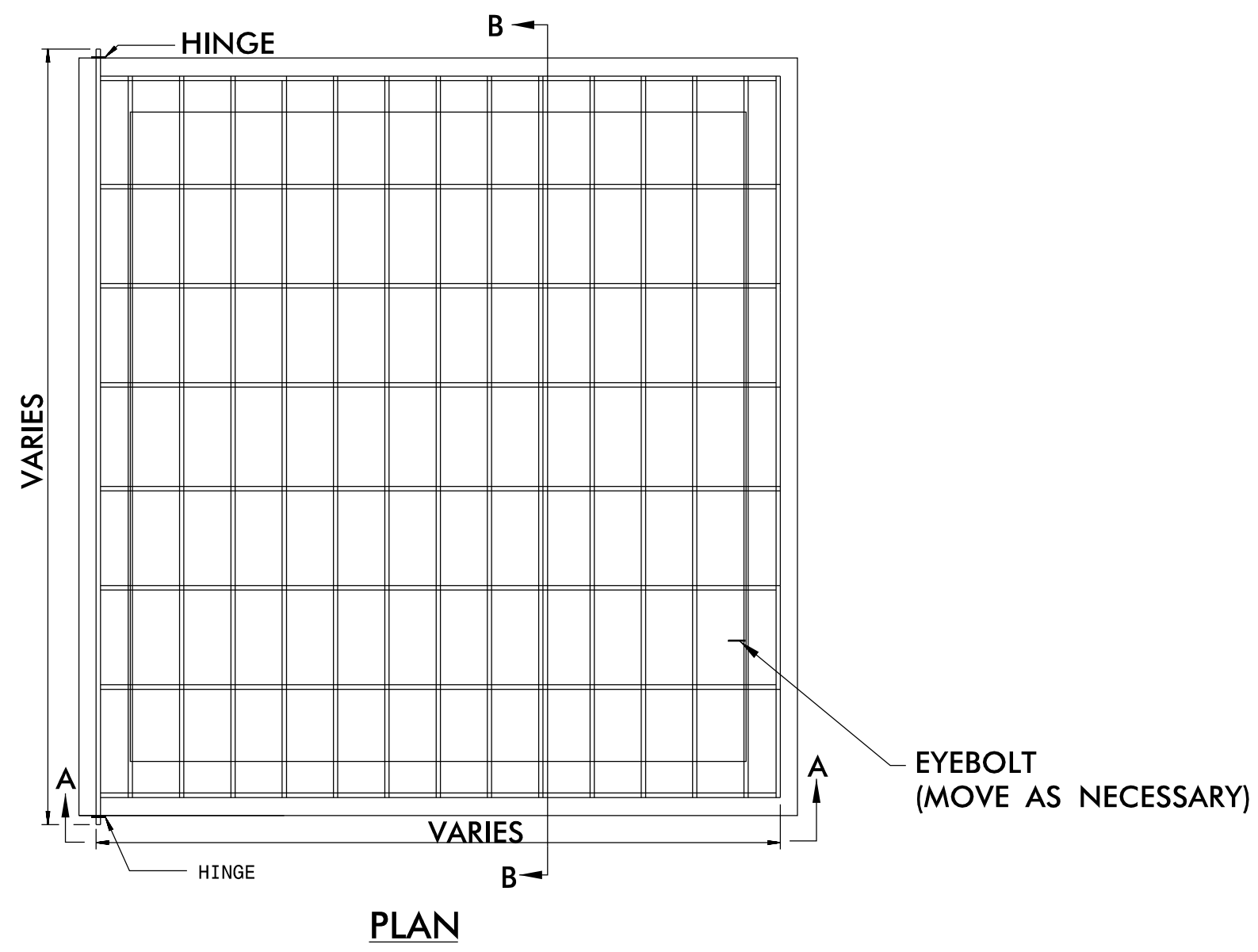

REBAR TRASH RACK NOT TO SCALE

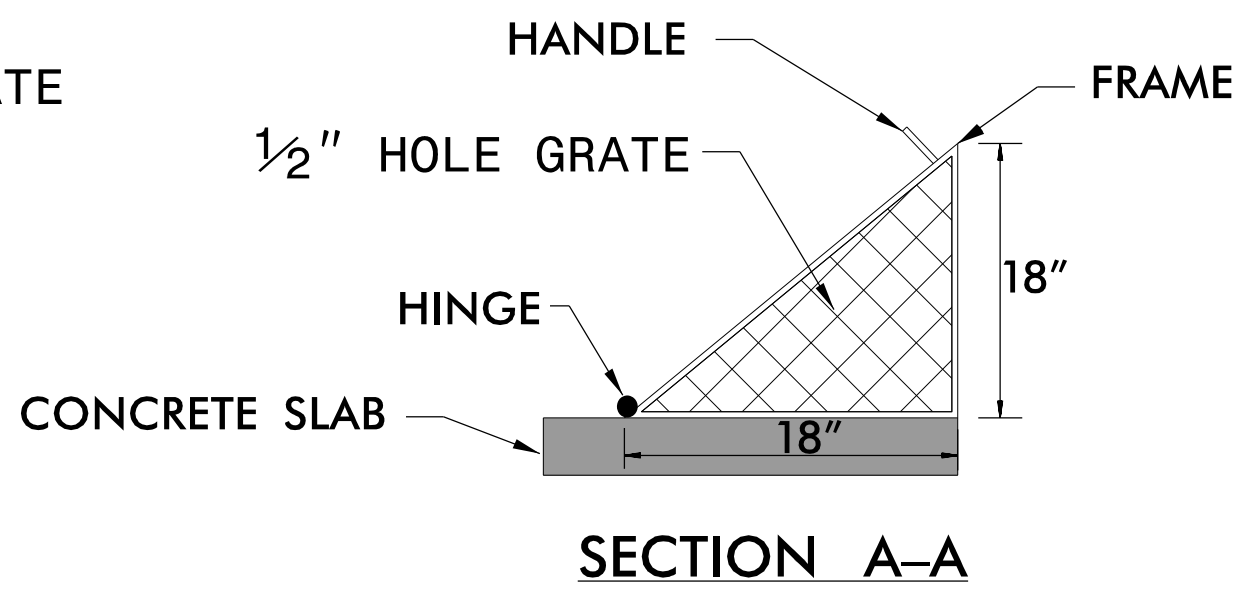
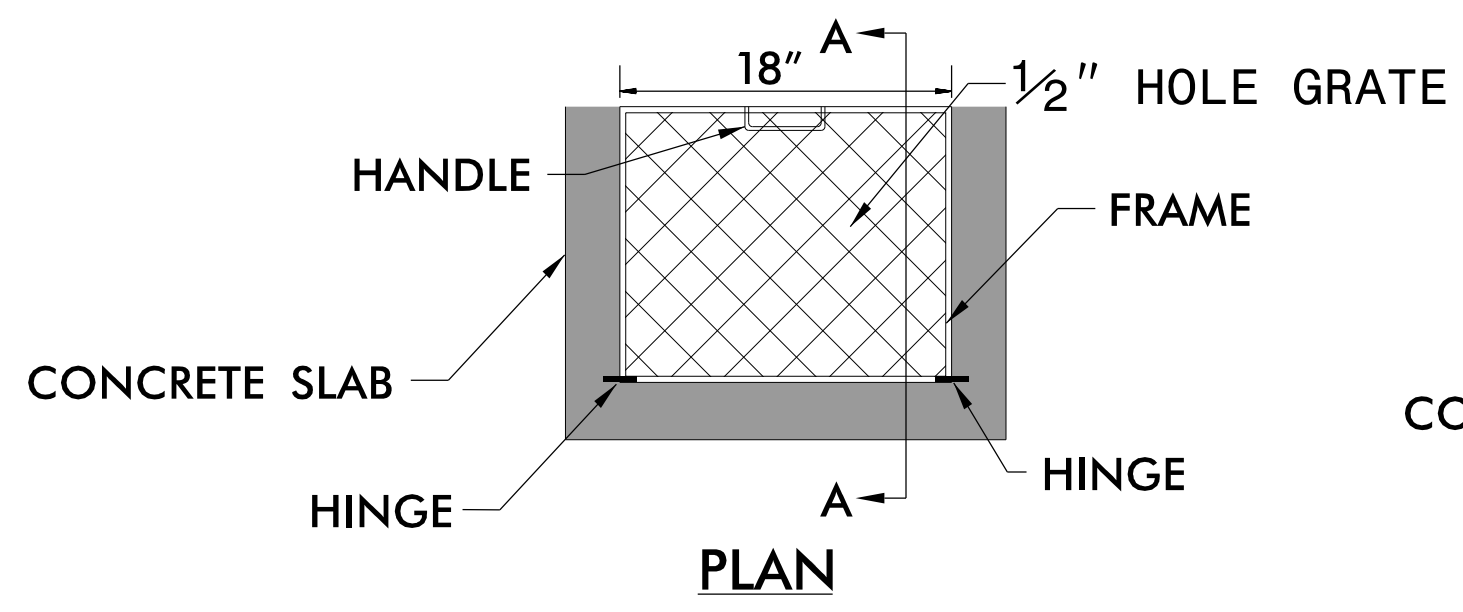
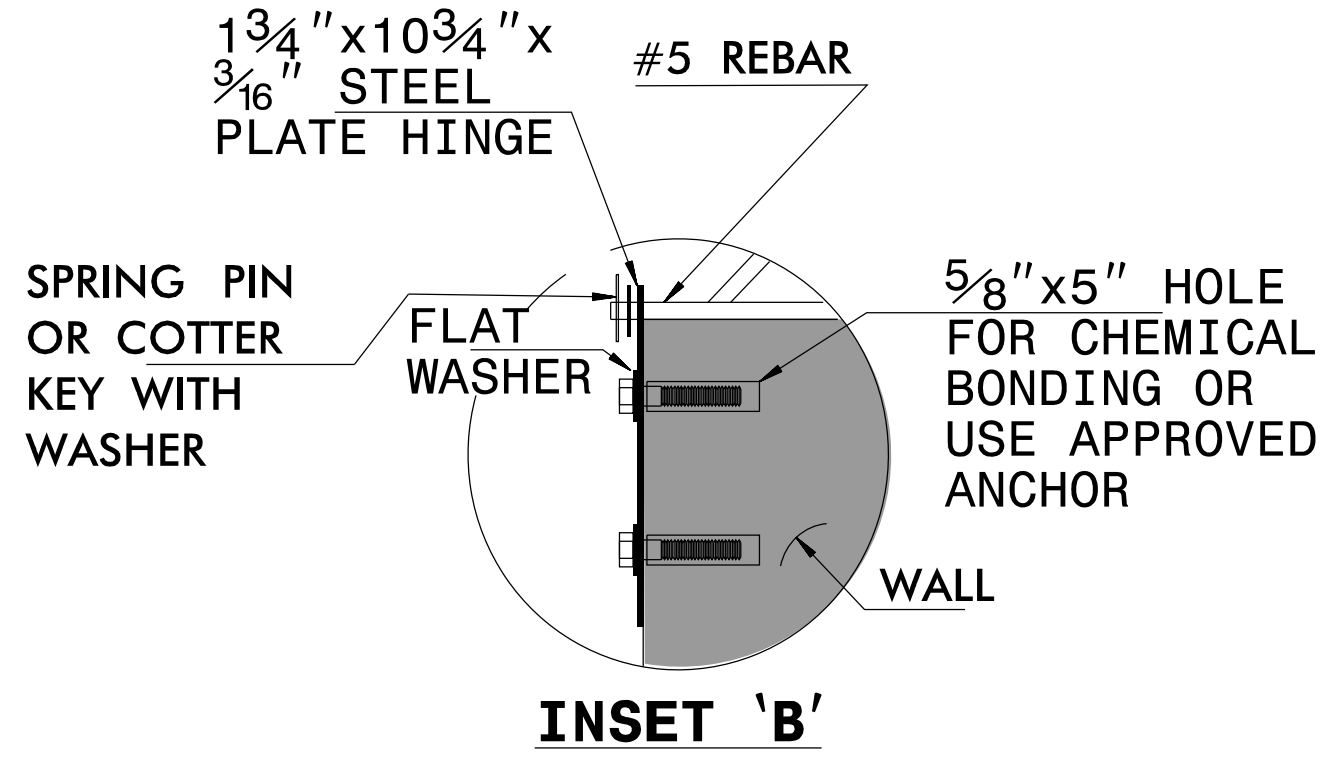
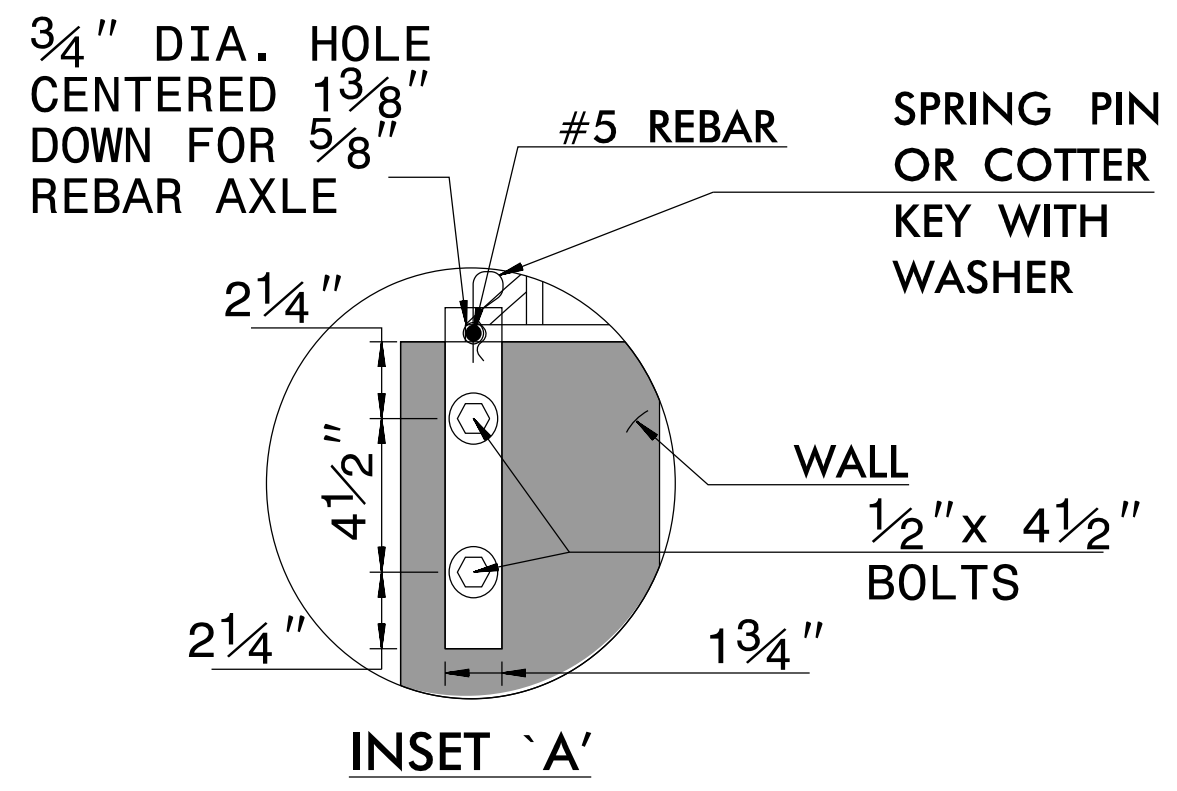

ORIFICE TRASH RACK NOT TO SCALE

ORIFICE TRASH RACK NOTES:

1. ALL JOINTS SHALL BE FULLY WELDED AROUND JOINT WITH A MINIMUM OF A 1/4" BEAD.
2. IF BOLTS ARE ANCHORED IN CONCRETE, FOLLOW STD. DWG. 862.03 AND 862.04 FOR ANCHORING PROCEDURE.
3. REMOVEABLE ORIFICE TRASH RACK SHALL BE ATTACHED TO CONCRETE BOX BY HINGE OR SLIDE RAIL SYSTEM.
4. RACK AND HARDWARE SHALL BE ALUMINUM OR GALVANIZED IN ACCORDANCE WITH ASTM A-153.