

6/2/2019

PAVEMENT SCHEDULE	
C2	3" S9.5C
D2	2 1/2" I19.0C
E1	4" B25.0C
R1	2'-6" C&G
R2	EXPRESSWAY GUTTER
R3	8" X 12" CURB
R4	SHOULDER BERM GUTTER
S	SIDEWALK
T	EARTH MATERIAL

PAVEMENT EDGE SLOPES ARE 1:1 UNLESS SHOWN OTHERWISE. SEE SHEET 2A-1 FOR DETAILED PAVEMENT SCHEDULE.

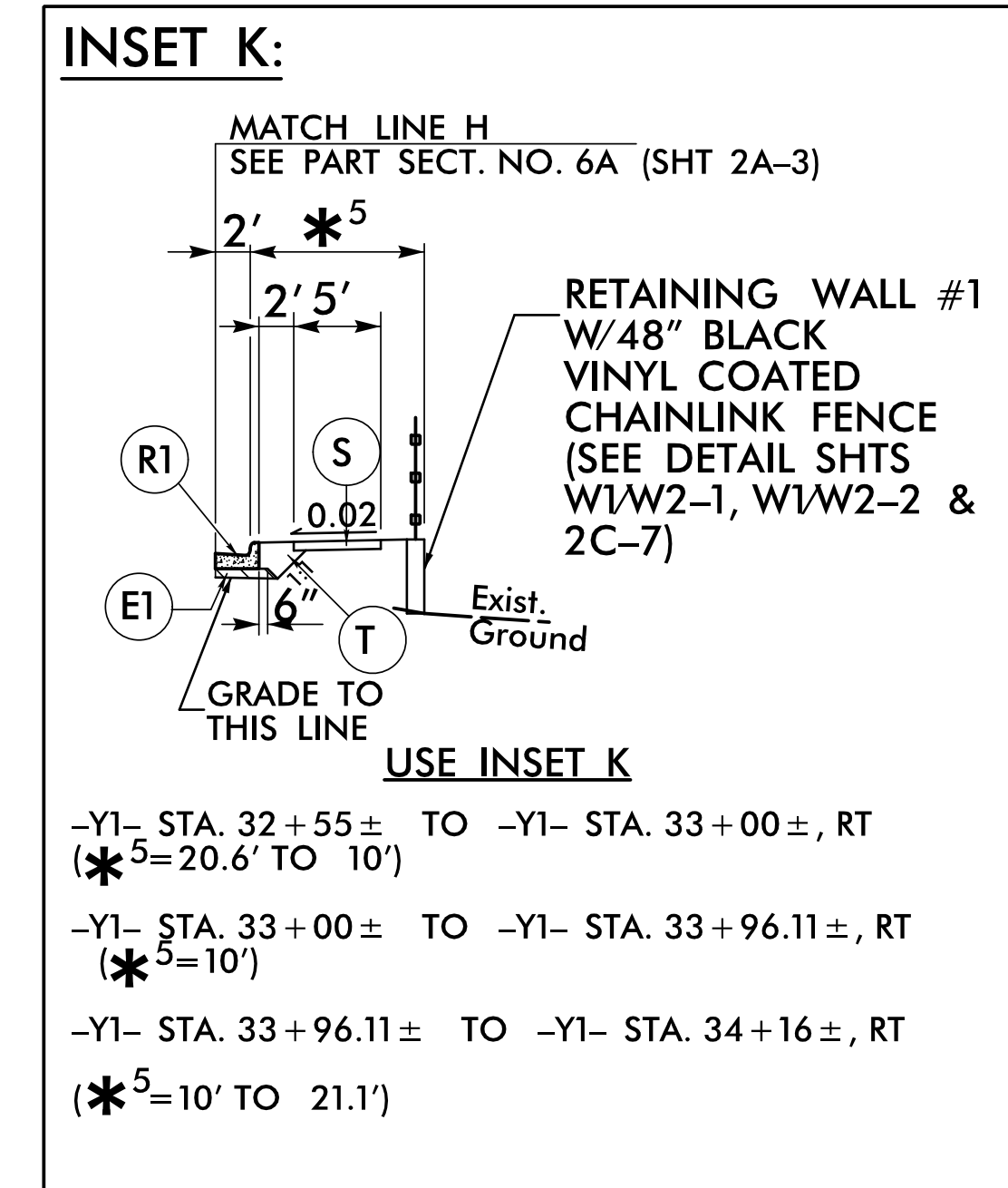
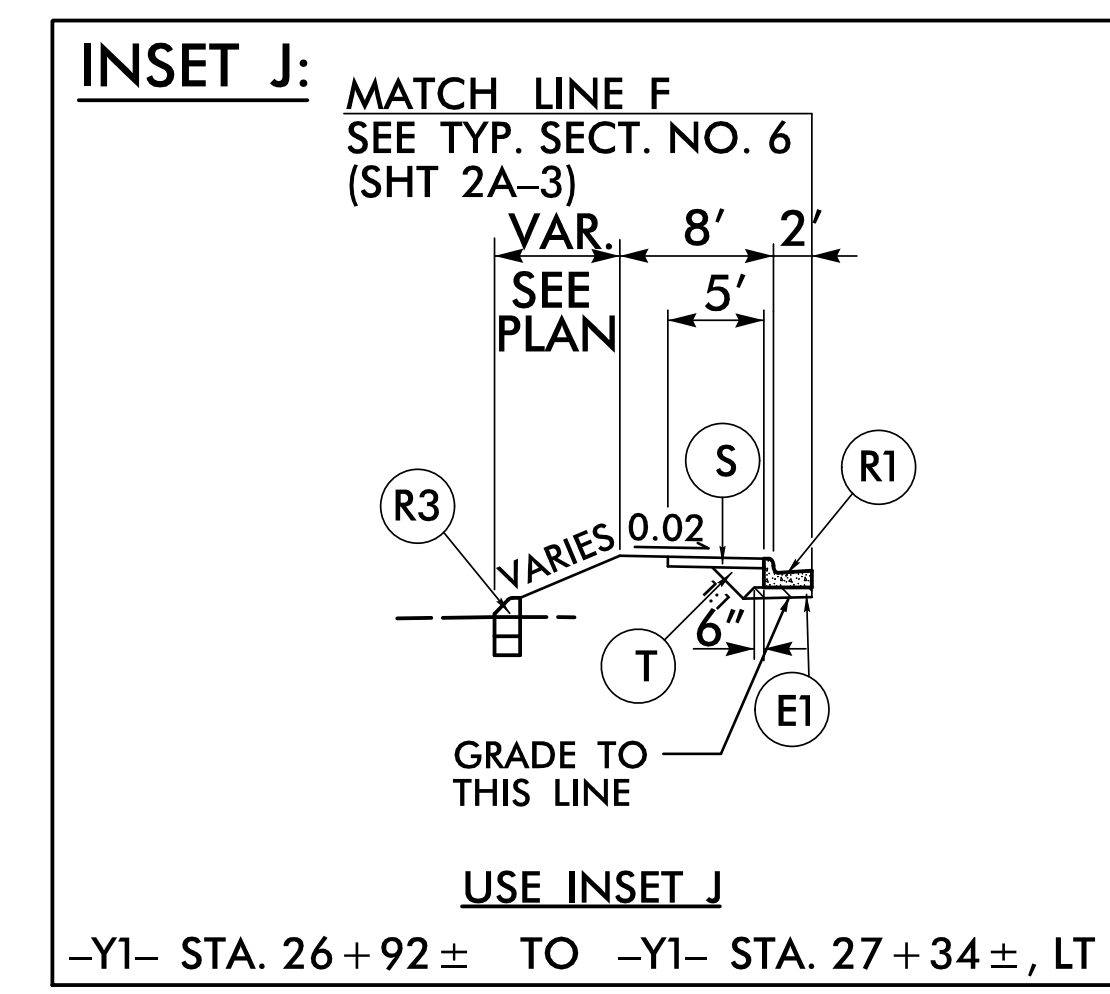
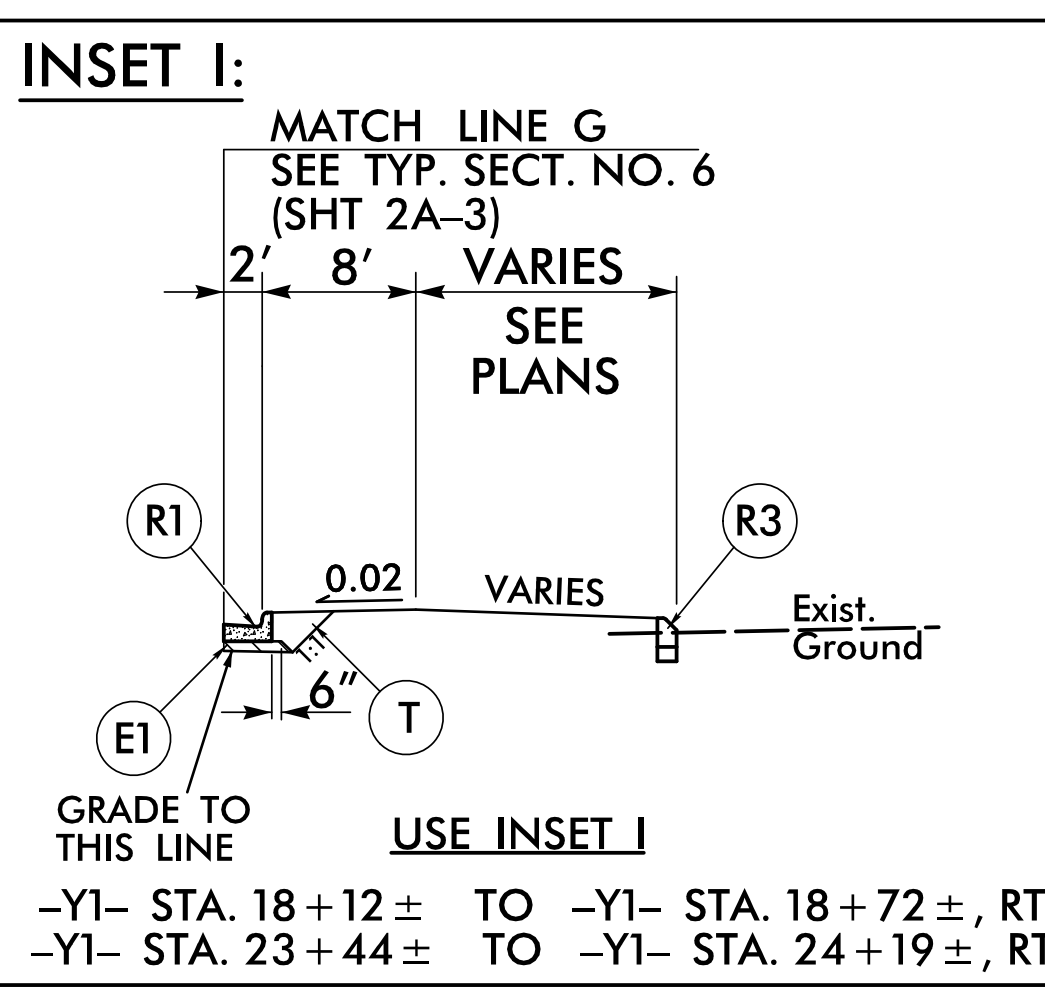
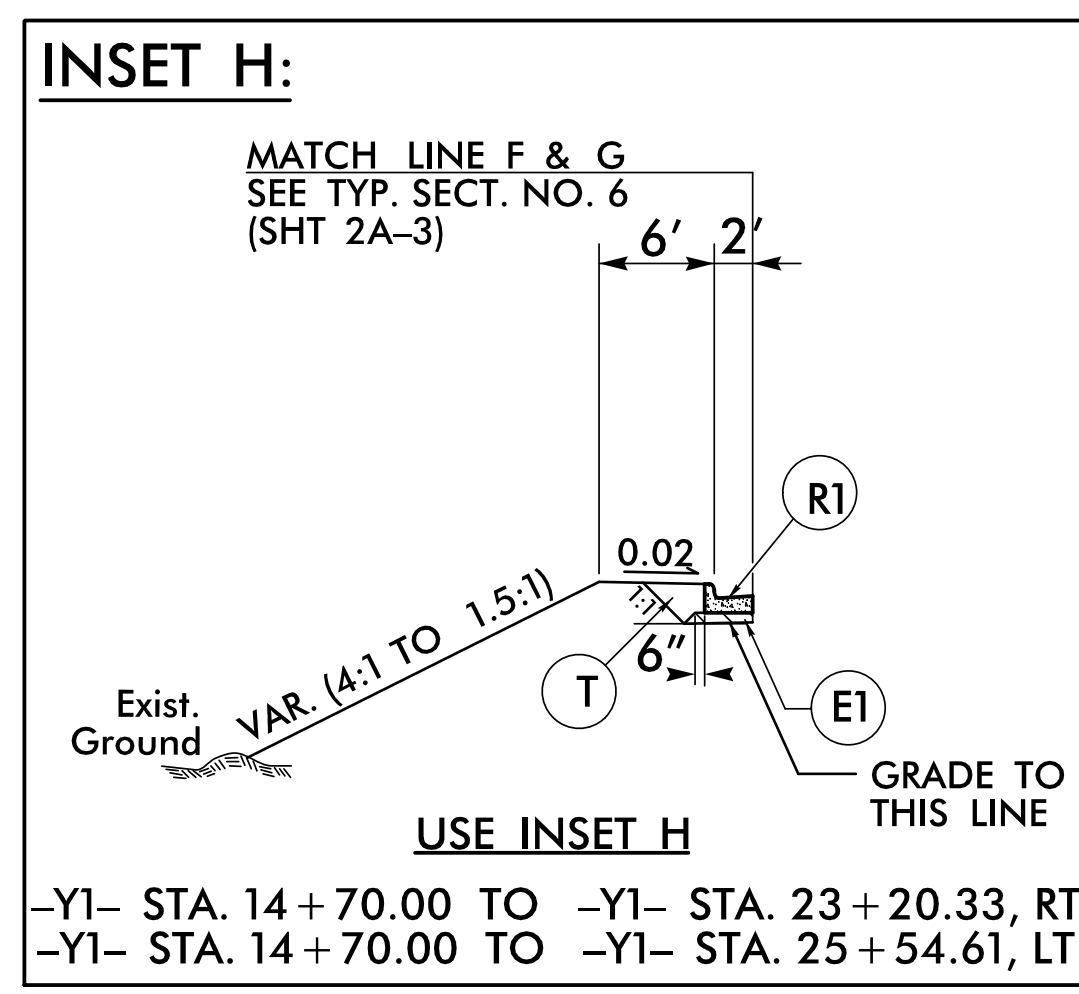
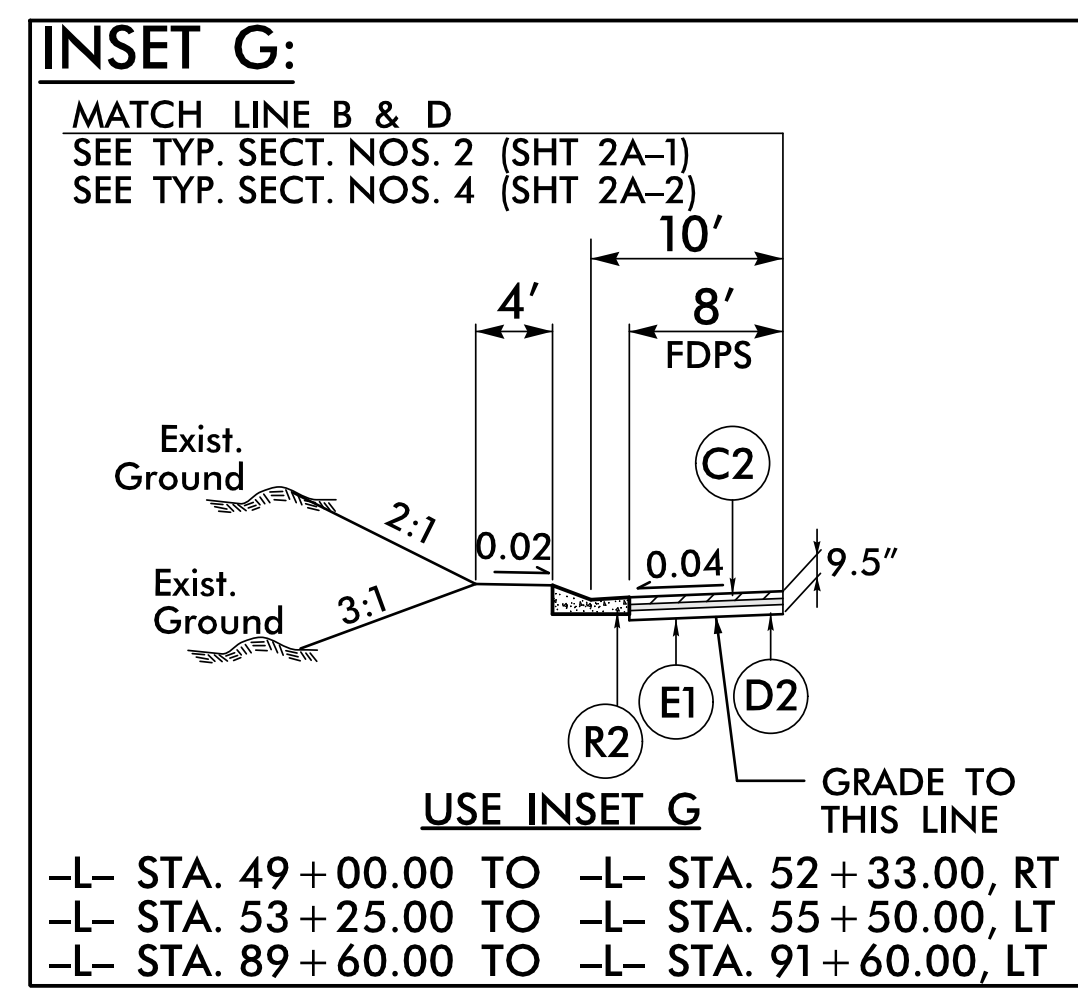
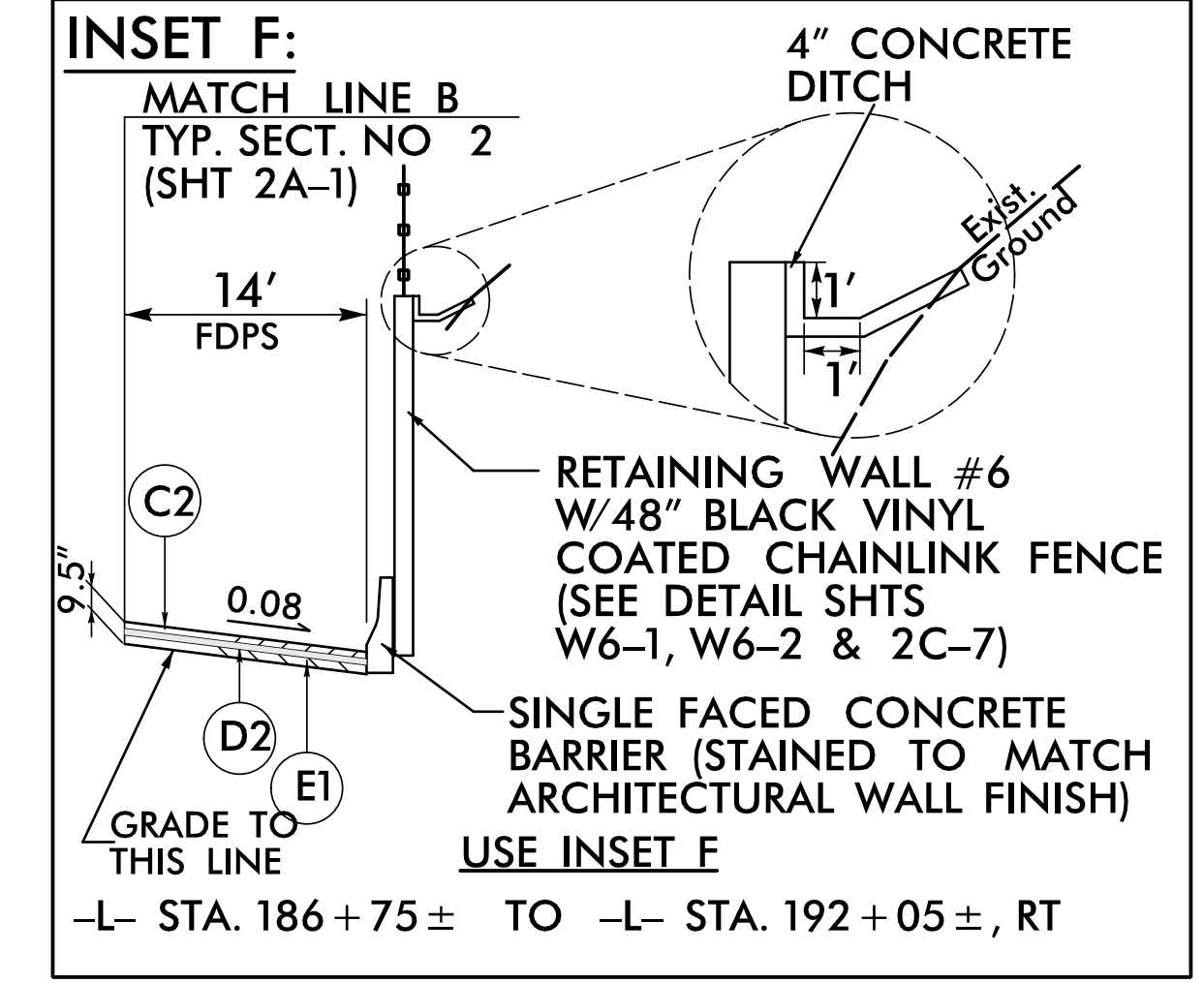
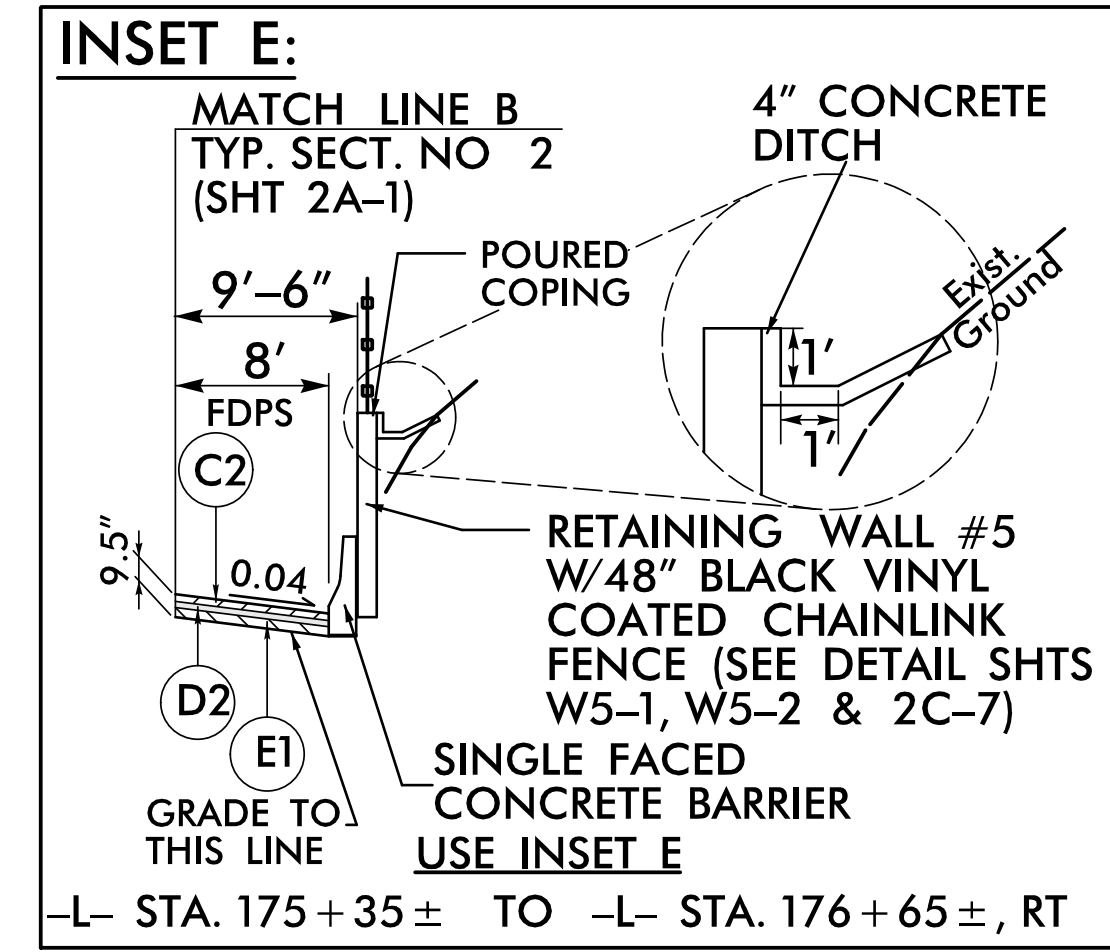
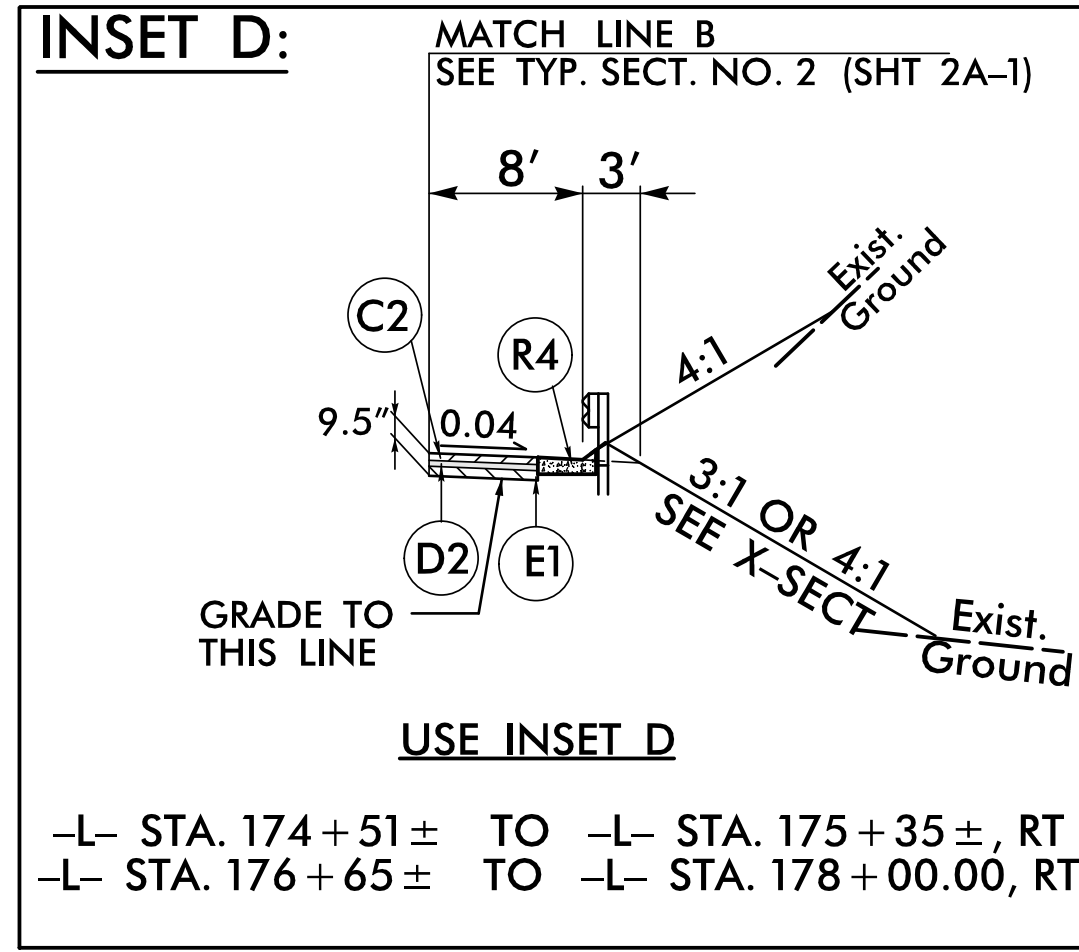
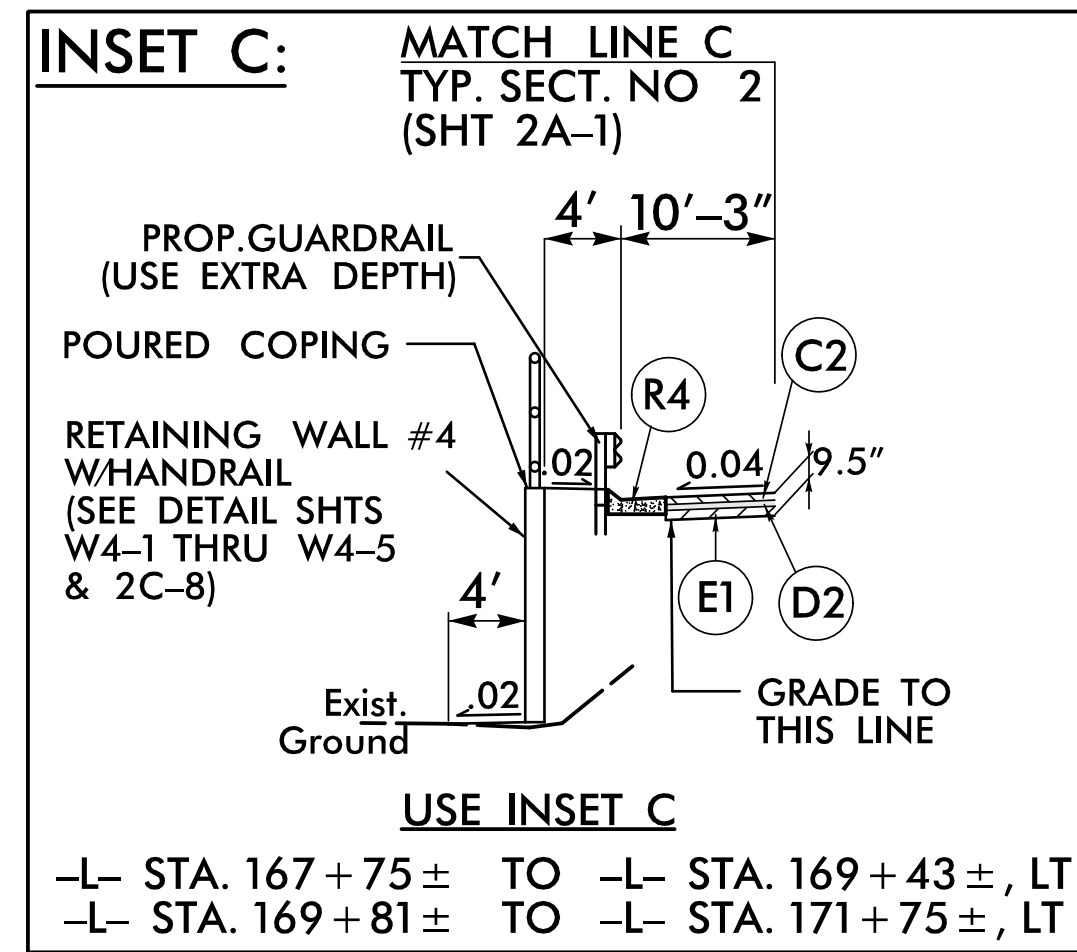
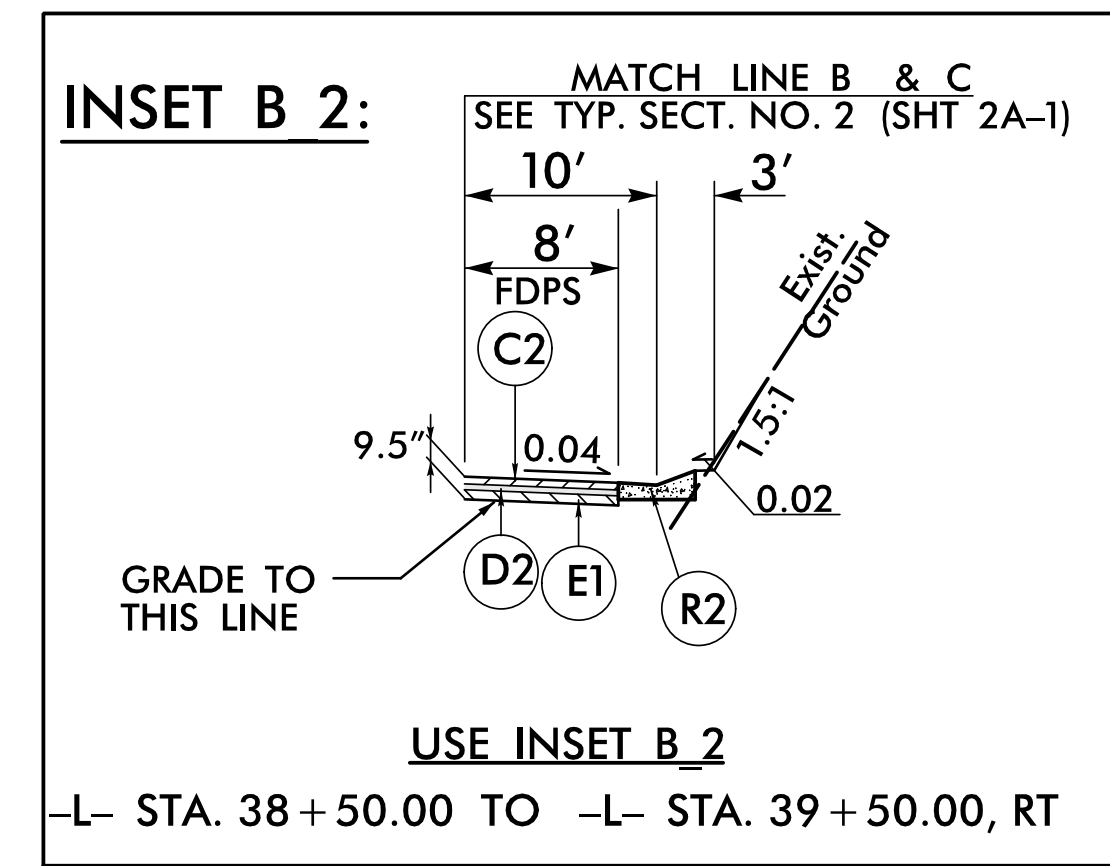
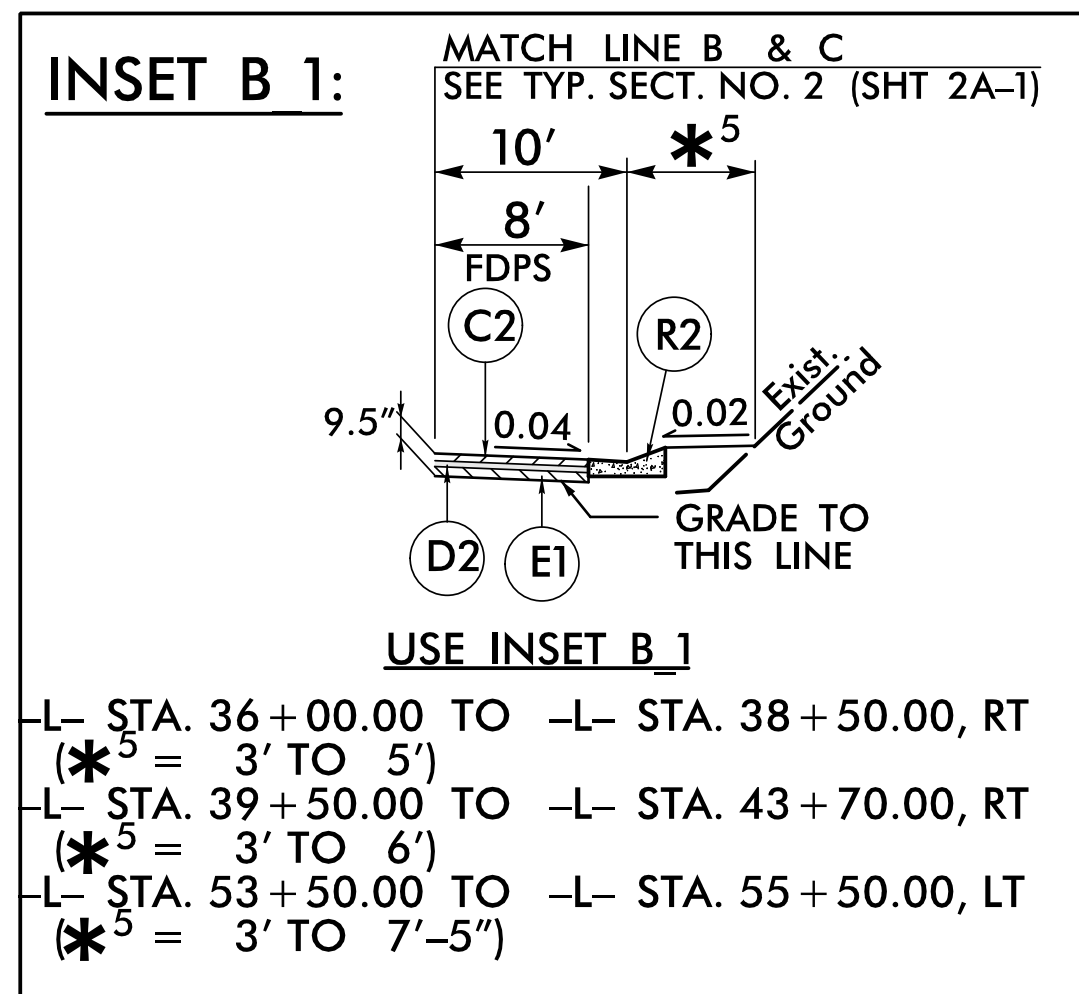
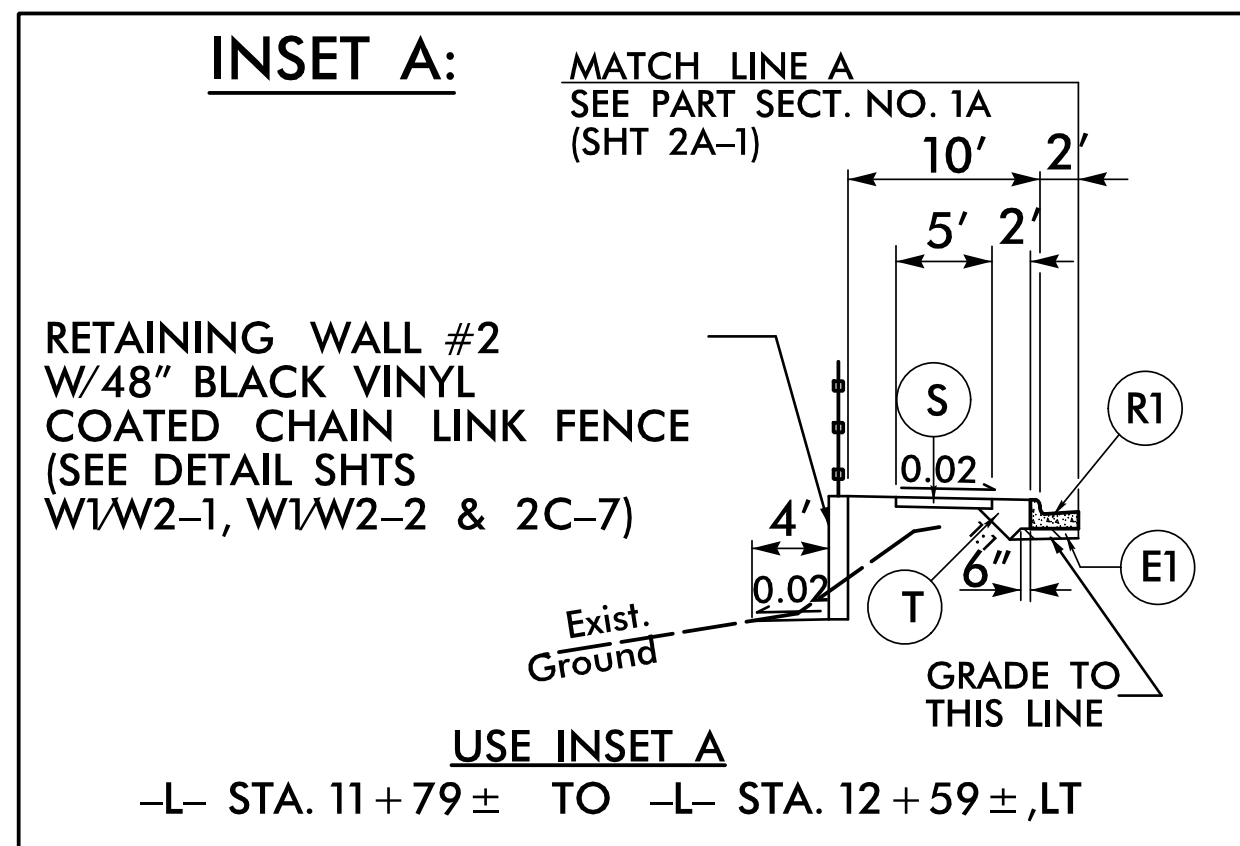

PROJECT REFERENCE NO. A-0009CA	SHEET NO. 2A-4
ROADWAY DESIGN ENGINEER JIMMY L. TERRY 35018 ENGINEER JULY 1, 2012	PAVEMENT DESIGN ENGINEER MATTHEW BREWER 041986 ENGINEER JULY 31, 2022
DOCUMENT NOT CONSIDERED FINAL UNLESS ALL SIGNATURES COMPLETED	
TGS ENGINEERS 201 W. MARION ST SHELBY, NC 28150 PH (704) 476-0003 CORP. LICENSE NO.: C-0275	

X:\2019\2019\Roadway\Proj\A-0009CA\Plan_Sheets\A-0009CA_Rdy_tjy.dgn
 User: jlt
 Date: 6/2/2019 10:58:22 AM