

**This electronic collection of documents is provided
for the convenience of the user
and is Not a Certified Document –**

**The documents contained herein were originally issued
and sealed by the individuals whose names and license
numbers appear on each page, on the dates appearing
with their signature on that page.**

**This file or an individual page
shall not be considered a certified document.**

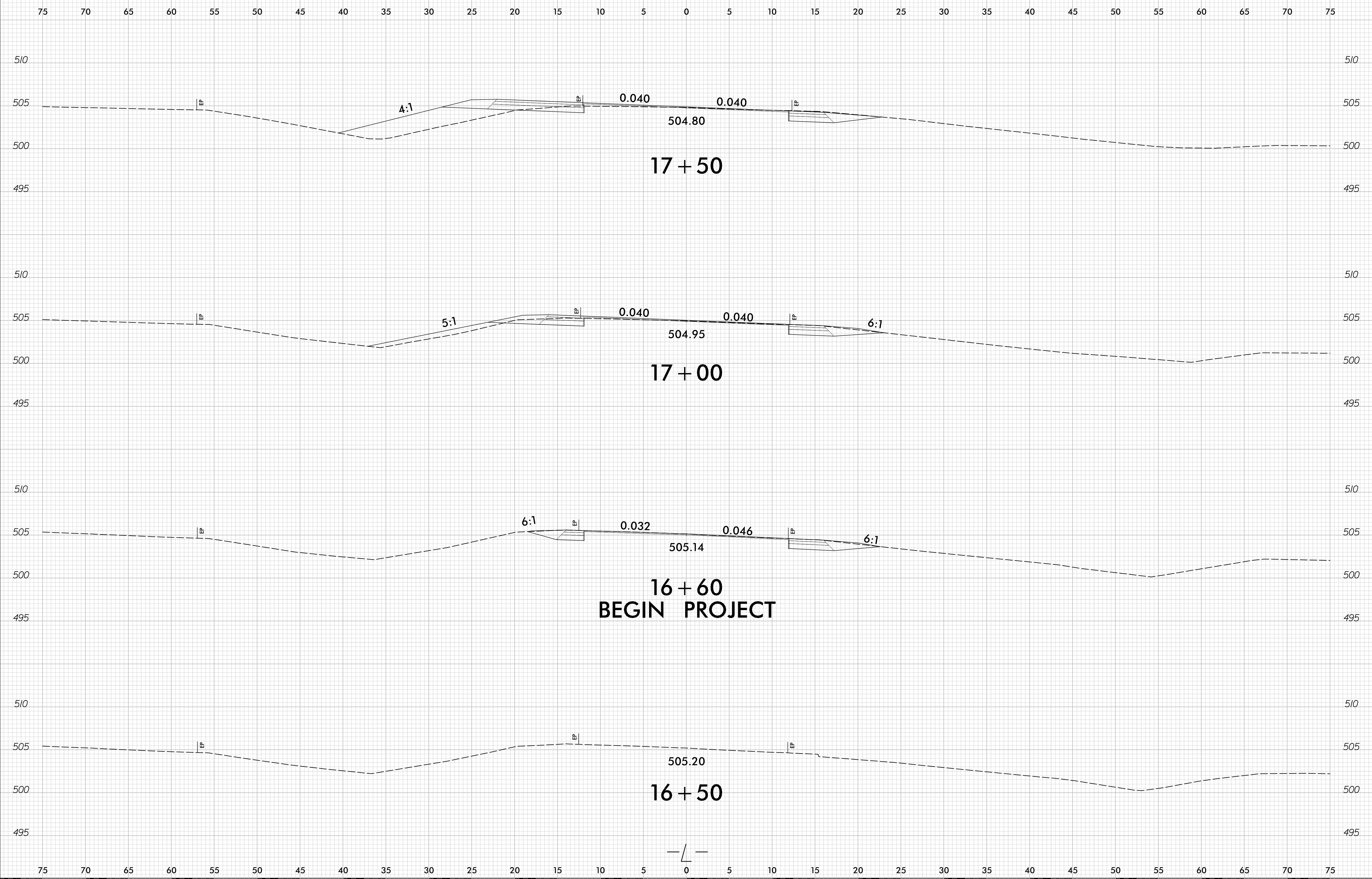

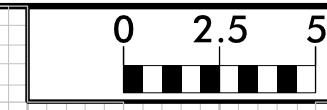

75 70 65 60 55 50 45 40 35 30 25 20 15 10 5 0 5 10 15 20 25 30 35 40 45 50 55 60 65 70 75

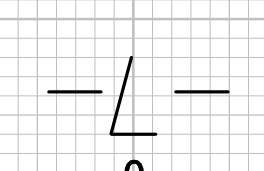
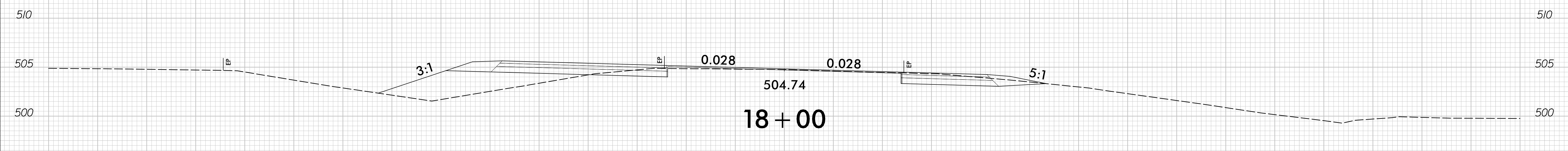
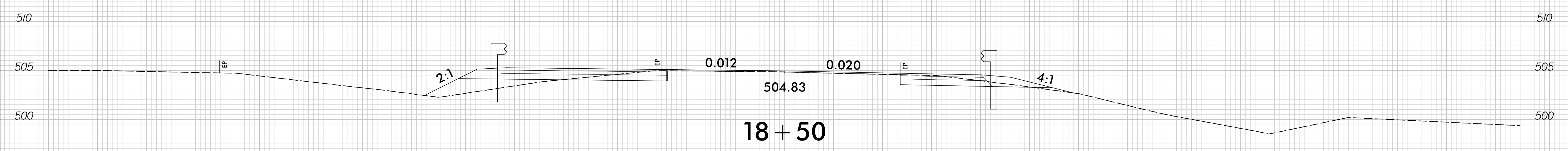
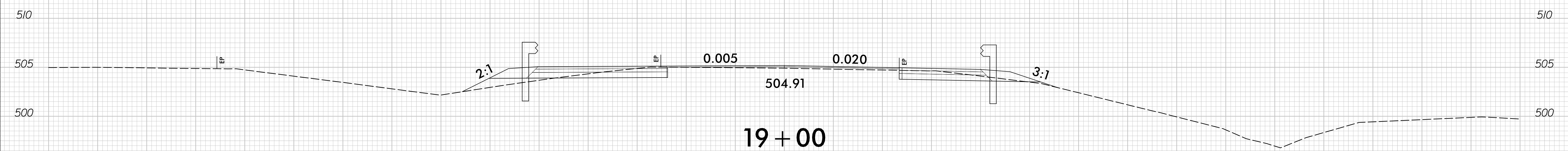

6/23/16

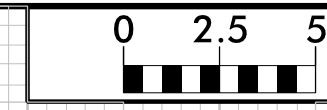

PROJ. REFERENCE NO. B-5810

SHEET NO. X-3

75 70 65 60 55 50 45 40 35 30 25 20 15 10 5 0 5 10 15 20 25 30 35 40 45 50 55 60 65 70 75

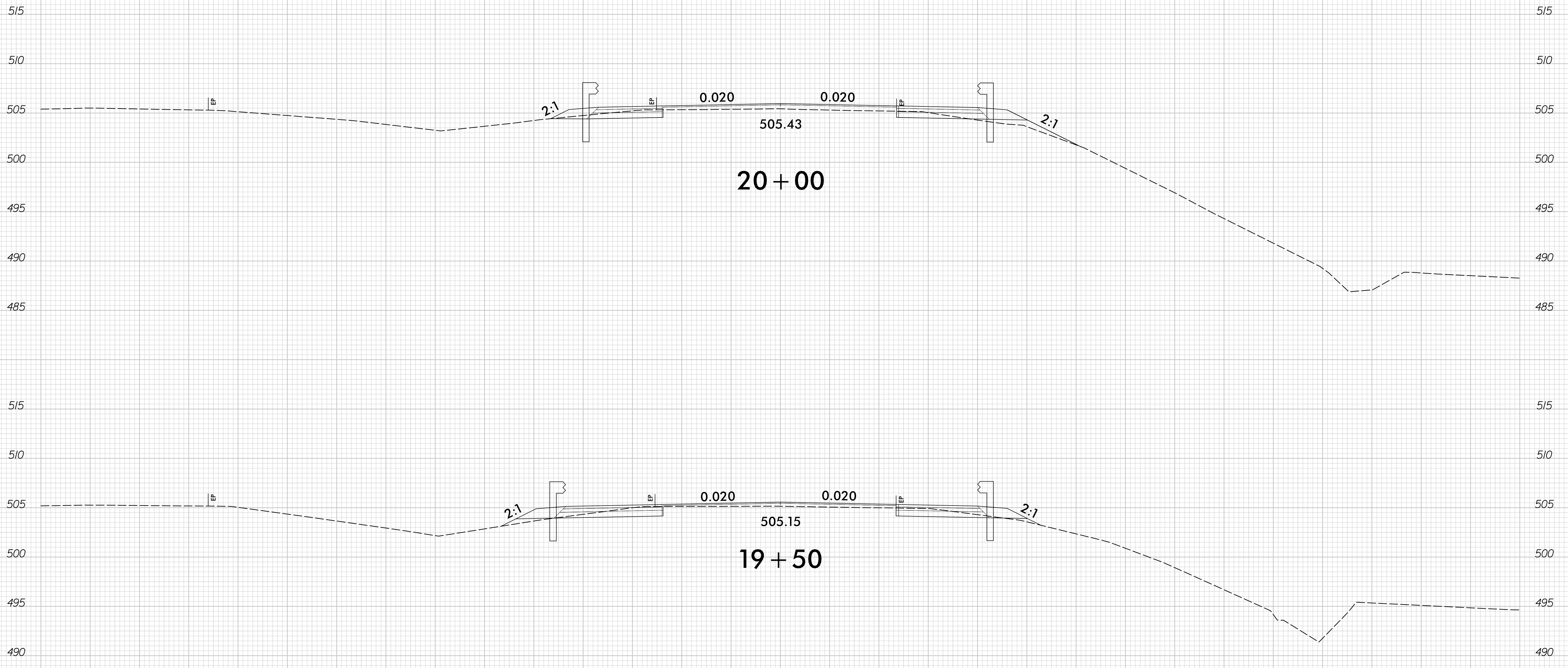

20 + 00

19 + 50

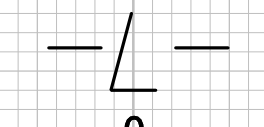

12/30/2021
 I:\Projects\B5810\Corridor Modeling\1_B5810_rdy_XPL_L.dgn
 jforbes

6/23/16

0 2.5 5	PROJ. REFERENCE NO. B-5810	SHEET NO. X-4
---------	-------------------------------	------------------

75 70 65 60 55 50 45 40 35 30 25 20 15 10 5 0 5 10 15 20 25 30 35 40 45 50 55 60 65 70 75

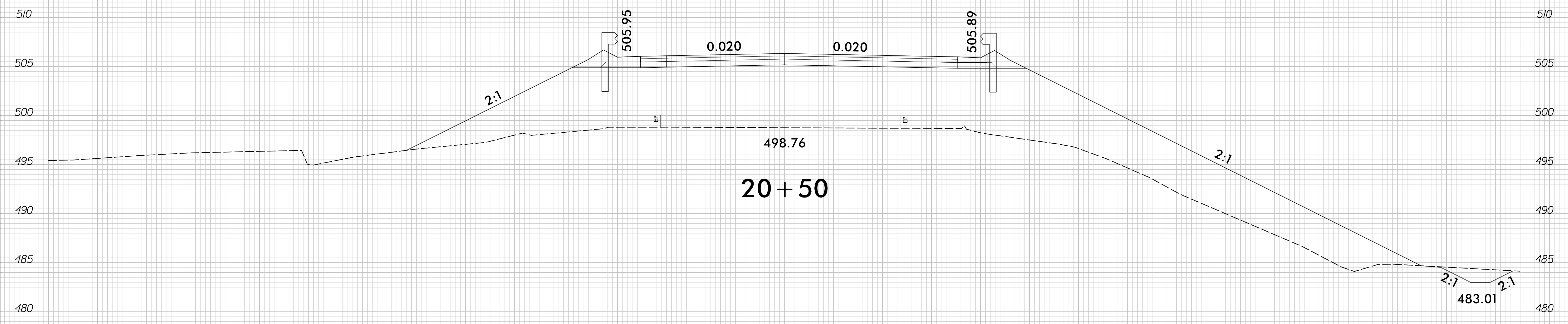
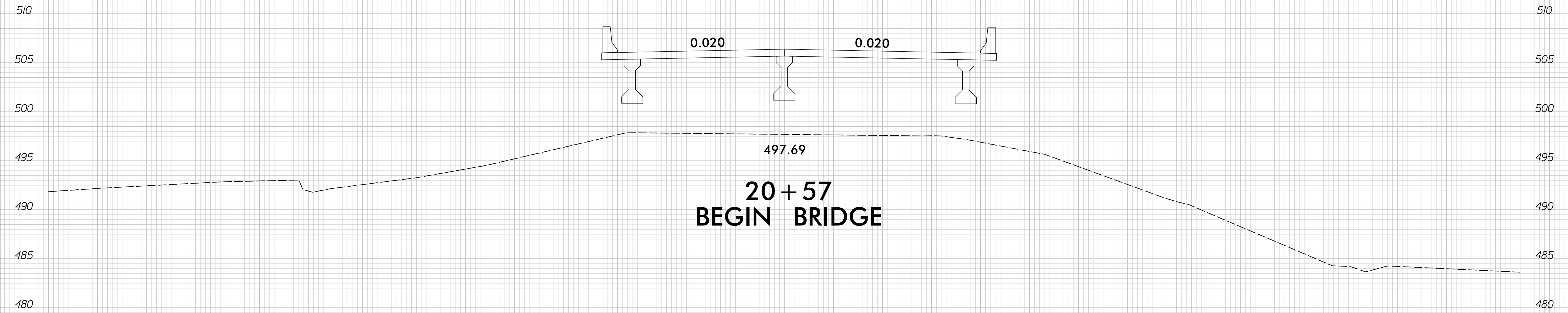

75 70 65 60 55 50 45 40 35 30 25 20 15 10 5 0 5 10 15 20 25 30 35 40 45 50 55 60 65 70 75

12/30/2021
I:\Projects\B5810\Corridor Modeling\B5810_rdy_XPL_L.dgn
Borrelli

75 70 65 60 55 50 45 40 35 30 25 20 15 10 5 0 5 10 15 20 25 30 35 40 45 50 55 60 65 70 75

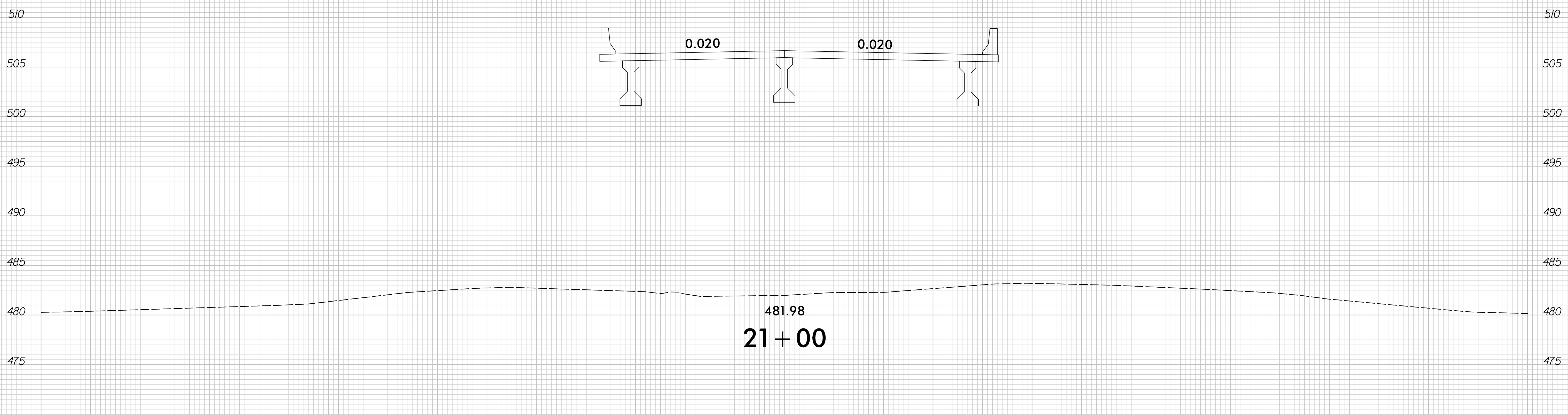

75 70 65 60 55 50 45 40 35 30 25 20 15 10 5 0 5 10 15 20 25 30 35 40 45 50 55 60 65 70 75

6/23/16

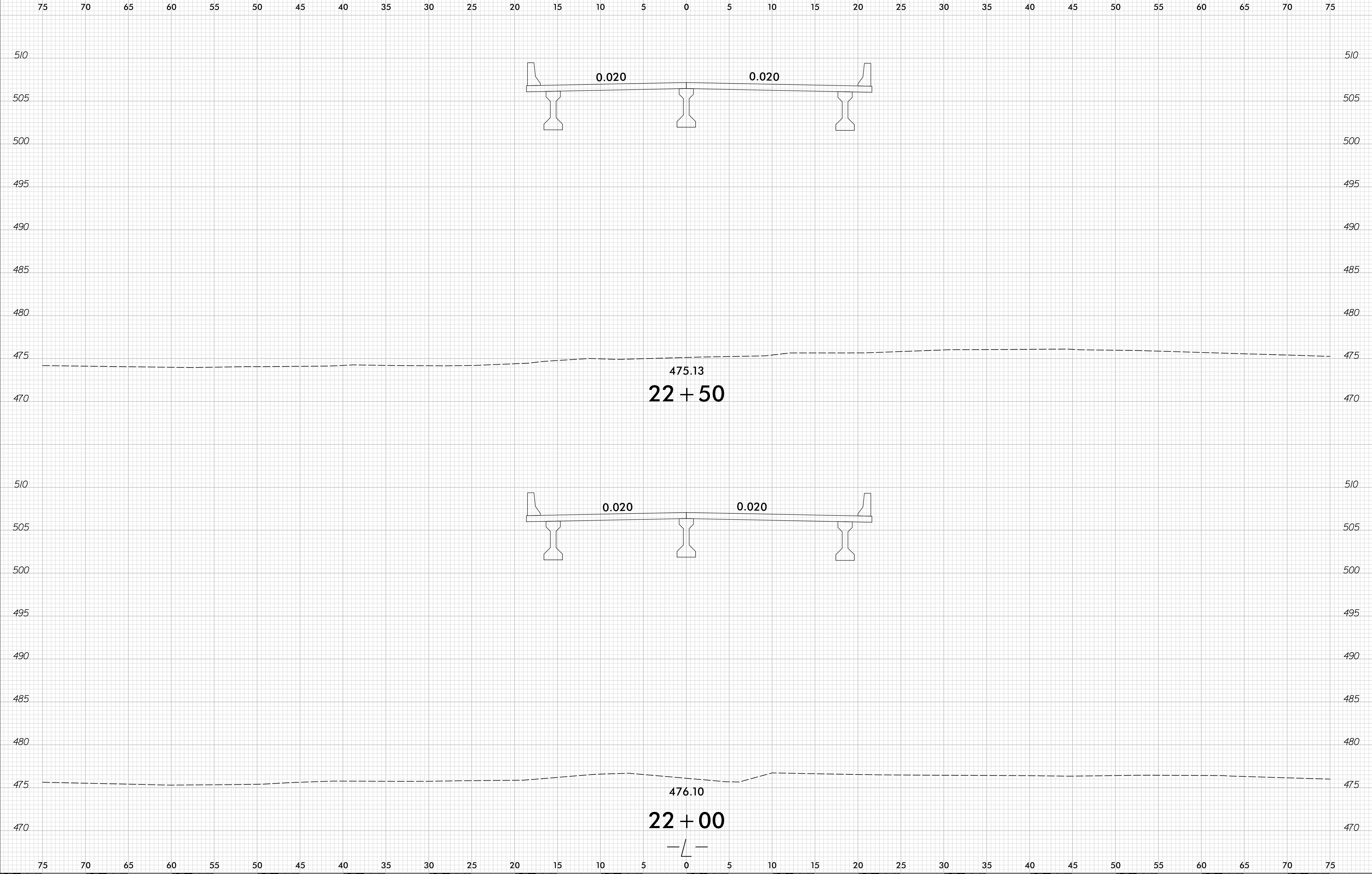

12/30/2021
I:\Projects\Corridor Modeling\B5810\rdj_XPL_L.dgn
rdj

75 70 65 60 55 50 45 40 35 30 25 20 15 10 5 0 5 10 15 20 25 30 35 40 45 50 55 60 65 70 75

510 510

505 505

500 500

495 495

490 490

485 485

480 480

475 475

470 470

510 510

505 505

500 500

495 495

490 490

485 485

480 480

475 475

470 470

75 70 65 60 55 50 45 40 35 30 25 20 15 10 5 0 5 10 15 20 25 30 35 40 45 50 55 60 65 70 75

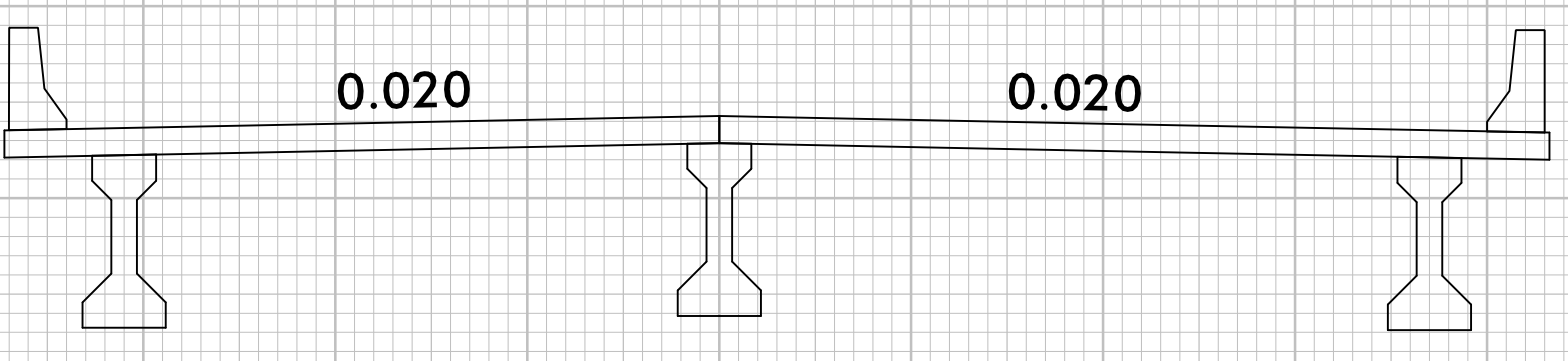

477.04
23 + 50

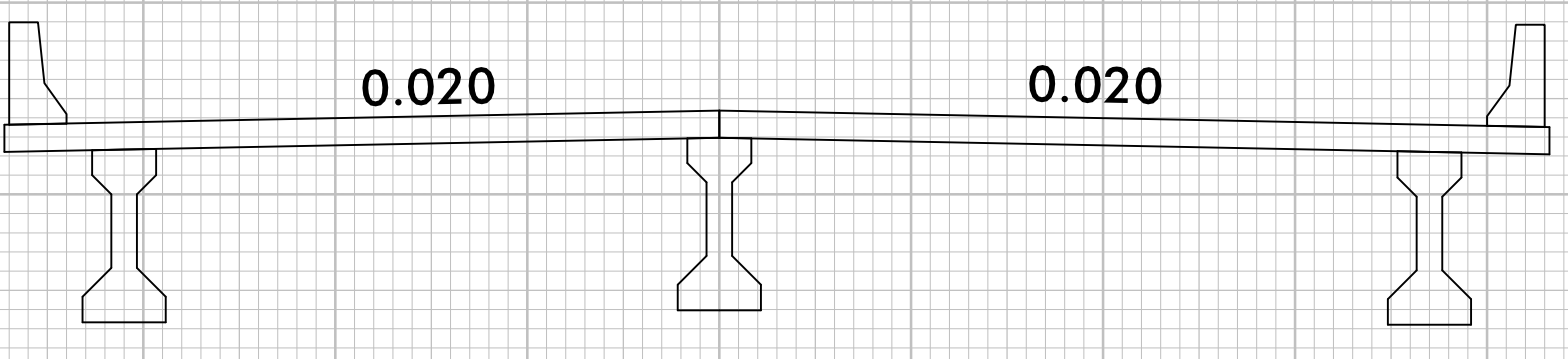

475.66
23 + 00

6/23/16

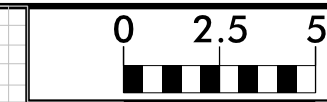

PROJ. REFERENCE NO.
B-5810

SHEET NO.
X-8

75 70 65 60 55 50 45 40 35 30 25 20 15 10 5 0 5 10 15 20 25 30 35 40 45 50 55 60 65 70 75

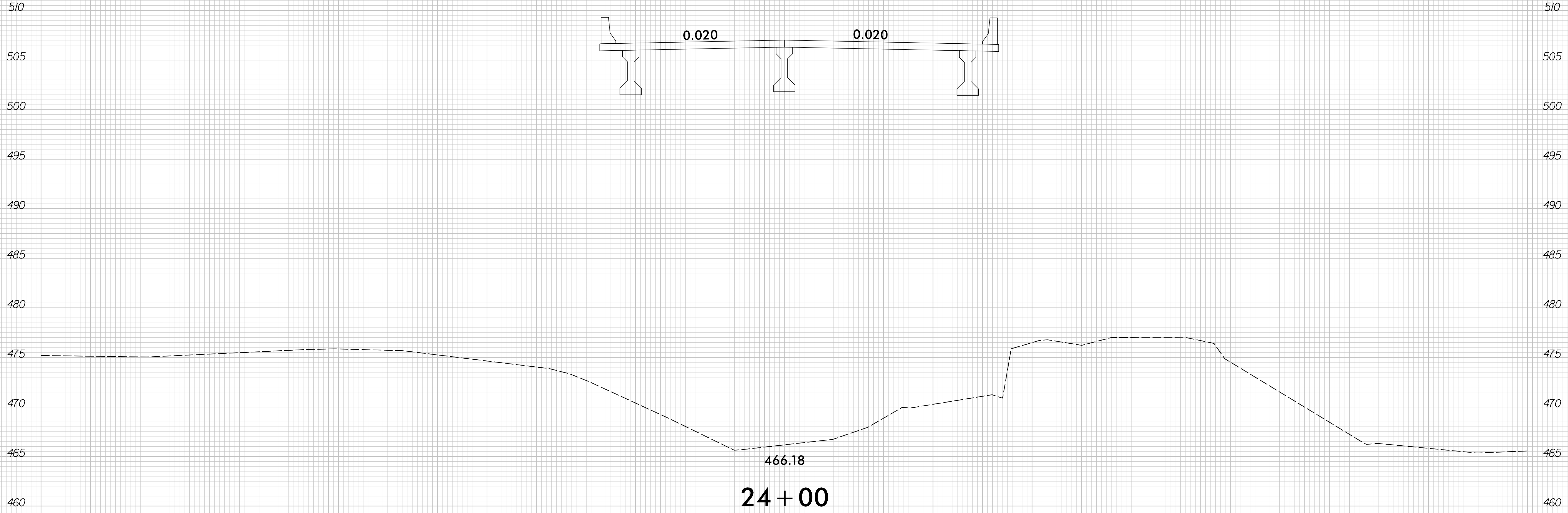

75 70 65 60 55 50 45 40 35 30 25 20 15 10 5 0 5 10 15 20 25 30 35 40 45 50 55 60 65 70 75

12/30/2021
R:\cadd\ay\Corridor Modeling\1_B5810_rdy_XPL_L.dgn
forBDS

6/23/16

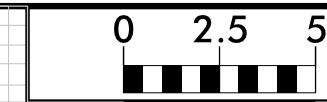

PROJ. REFERENCE NO.	SHEET NO.
B-5810	X-9

75 70 65 60 55 50 45 40 35 30 25 20 15 10 5 0 5 10 15 20 25 30 35 40 45 50 55 60 65 70 75

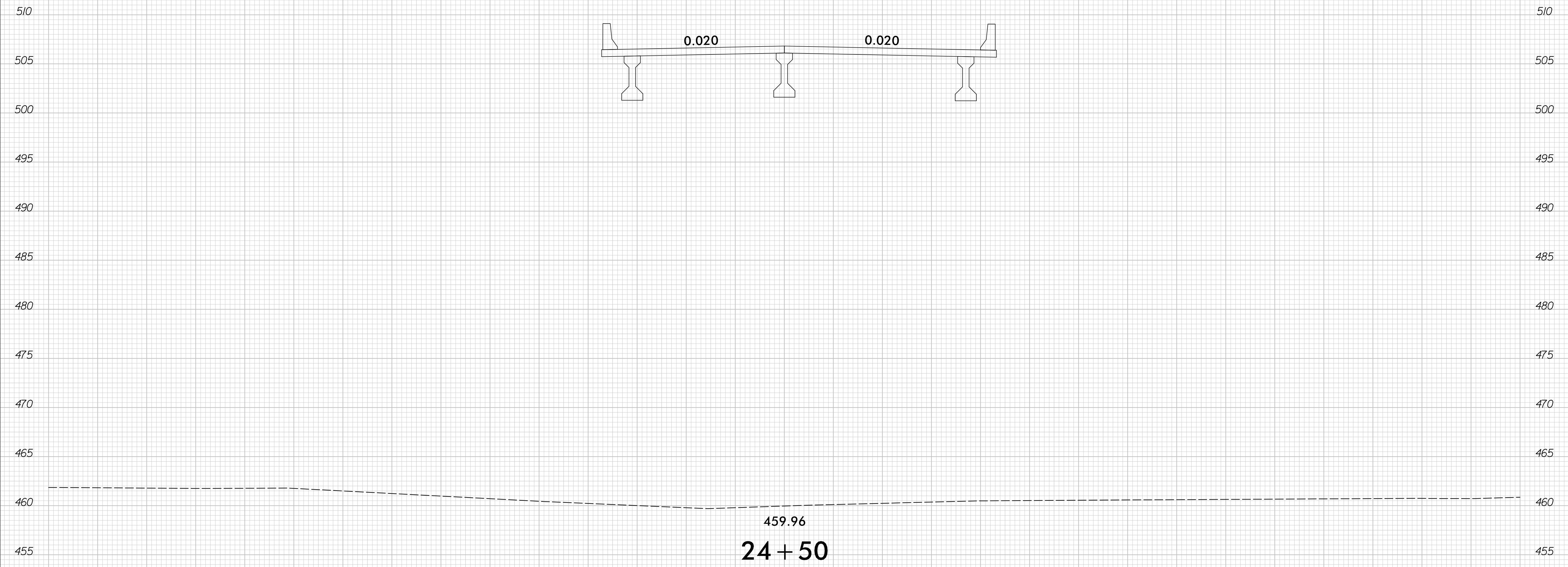

12/30/2021
 P:\cadd\ay\Corridor Modeling\B5810\rdj_XPL_L.dgn
 rdj

75 70 65 60 55 50 45 40 35 30 25 20 15 10 5 0 5 10 15 20 25 30 35 40 45 50 55 60 65 70 75

6/23/16

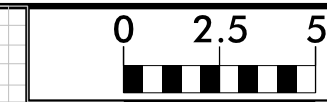

PROJ. REFERENCE NO.
B-5810

SHEET NO.
X-10

75 70 65 60 55 50 45 40 35 30 25 20 15 10 5 0 5 10 15 20 25 30 35 40 45 50 55 60 65 70 75

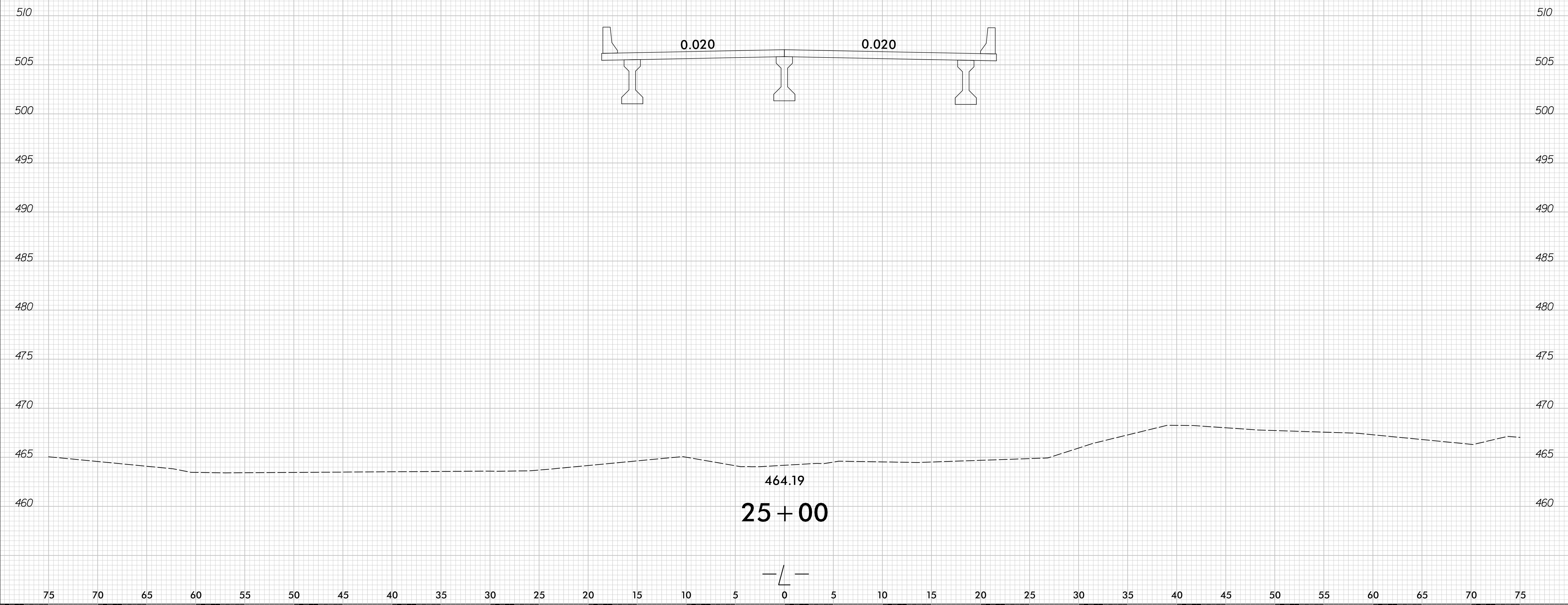

12/30/2021
I:\Projects\B5810\Corridor Modeling\B5810_rdy_XPL_L.dgn
Borrelli

75 70 65 60 55 50 45 40 35 30 25 20 15 10 5 0 5 10 15 20 25 30 35 40 45 50 55 60 65 70 75

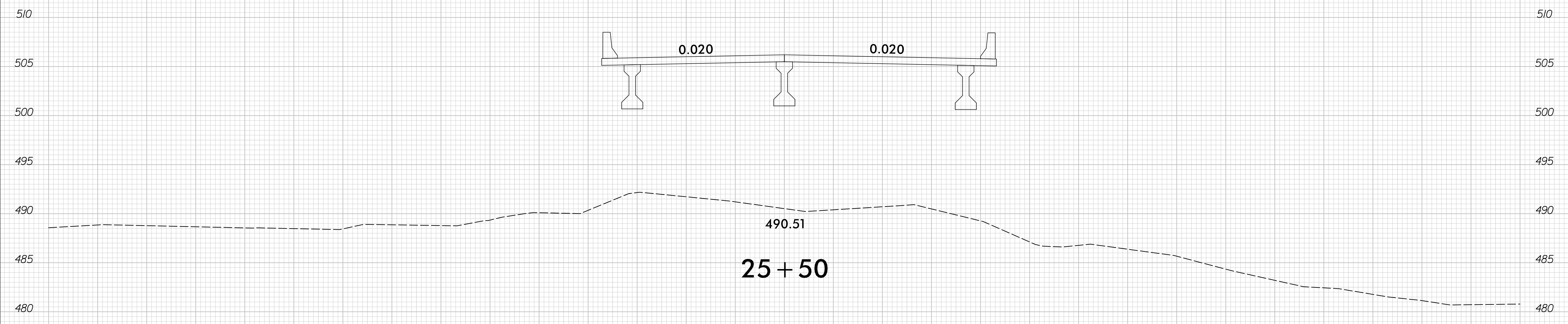
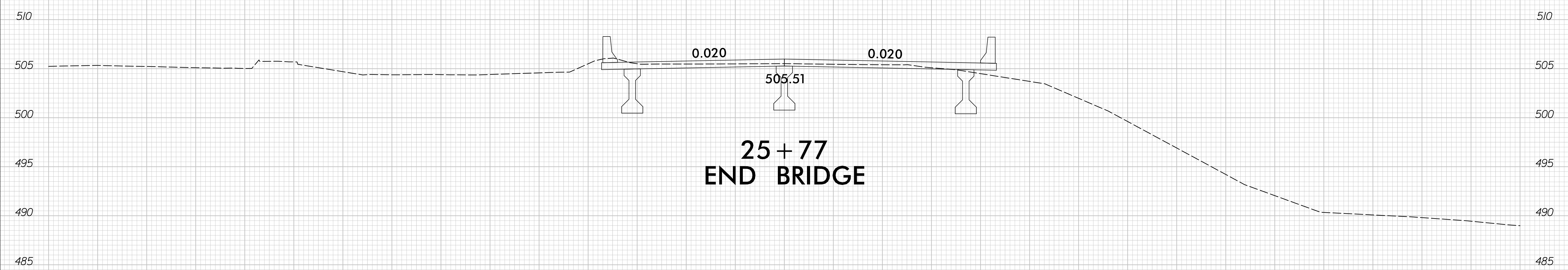

75 70 65 60 55 50 45 40 35 30 25 20 15 10 5 0 5 10 15 20 25 30 35 40 45 50 55 60 65 70 75

75 70 65 60 55 50 45 40 35 30 25 20 15 10 5 0 5 10 15 20 25 30 35 40 45 50 55 60 65 70 75

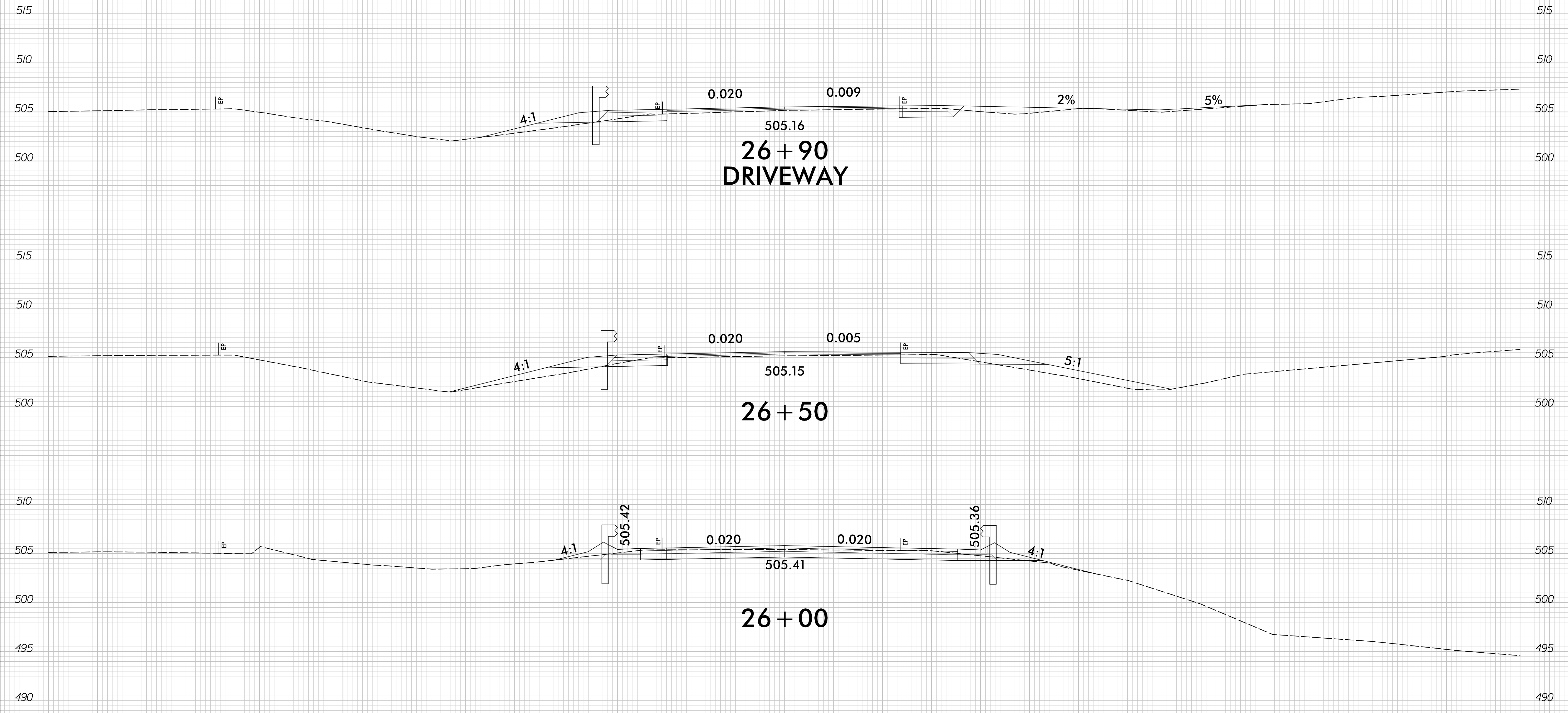

**26 + 90
DRIVEWAY**

26 + 50

26 + 00

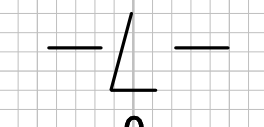

75 70 65 60 55 50 45 40 35 30 25 20 15 10 5 0 5 10 15 20 25 30 35 40 45 50 55 60 65 70 75

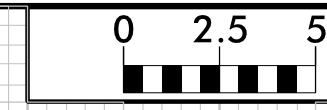

75 70 65 60 55 50 45 40 35 30 25 20 15 10 5 0 5 10 15 20 25 30 35 40 45 50 55 60 65 70 75

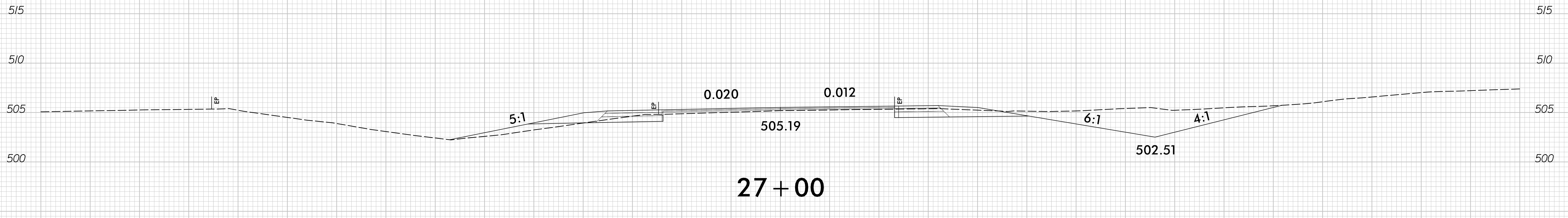
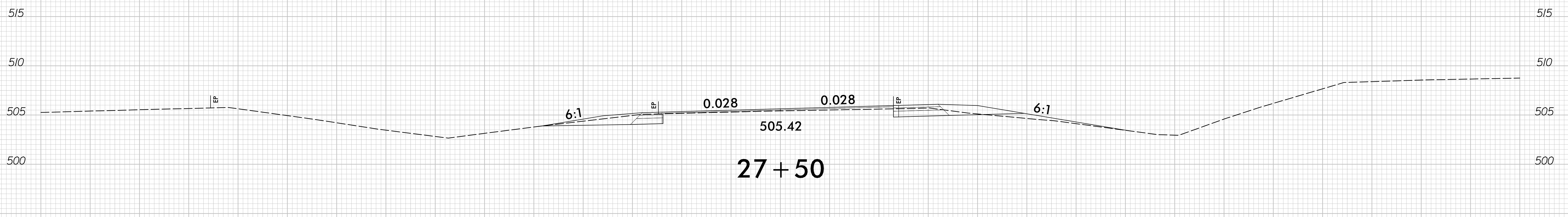
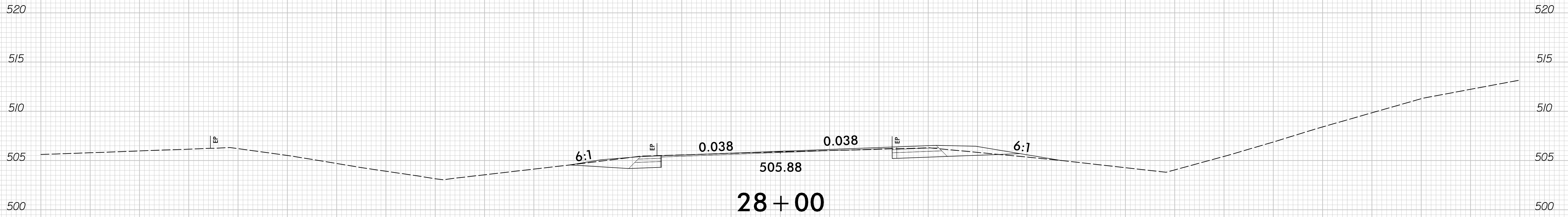

75 70 65 60 55 50 45 40 35 30 25 20 15 10 5 0 5 10 15 20 25 30 35 40 45 50 55 60 65 70 75

75 70 65 60 55 50 45 40 35 30 25 20 15 10 5 0 5 10 15 20 25 30 35 40 45 50 55 60 65 70 75

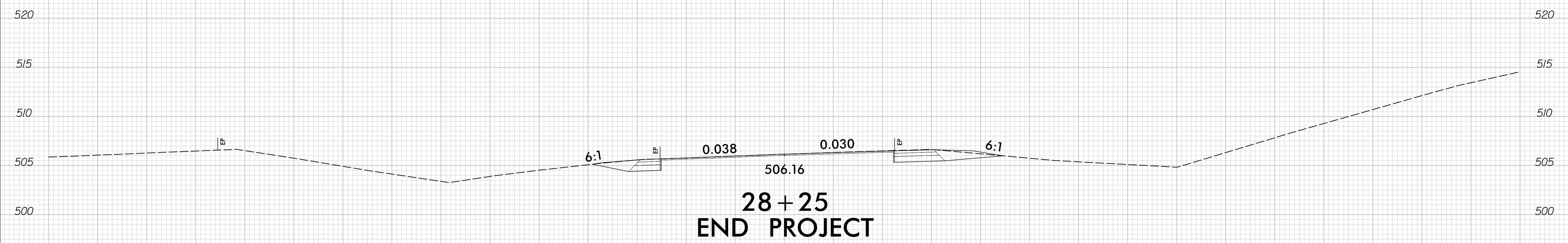
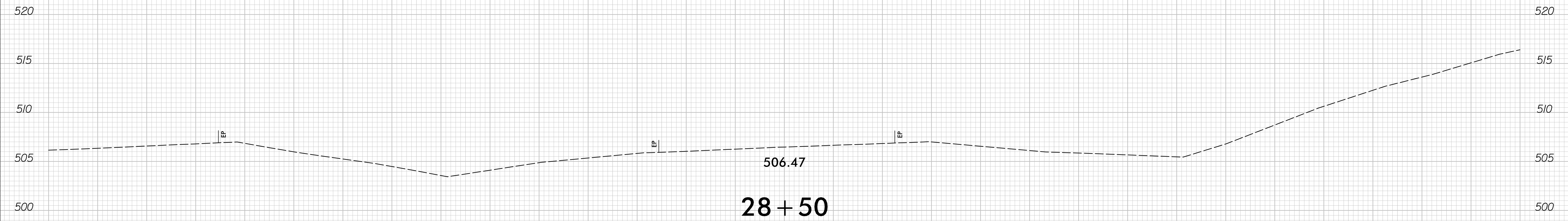

75 70 65 60 55 50 45 40 35 30 25 20 15 10 5 0 5 10 15 20 25 30 35 40 45 50 55 60 65 70 75

75 70 65 60 55 50 45 40 35 30 25 20 15 10 5 0 5 10 15 20 25 30 35 40 45 50 55 60 65 70 75

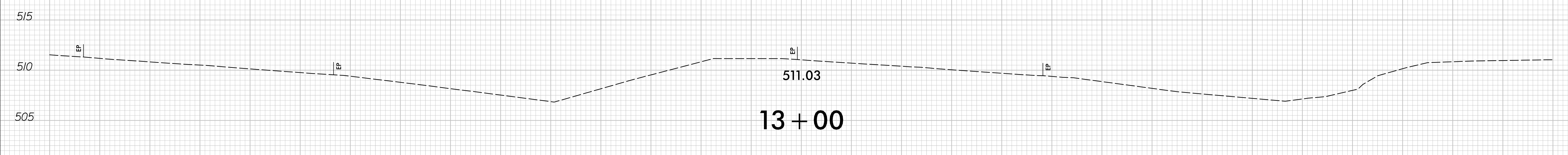
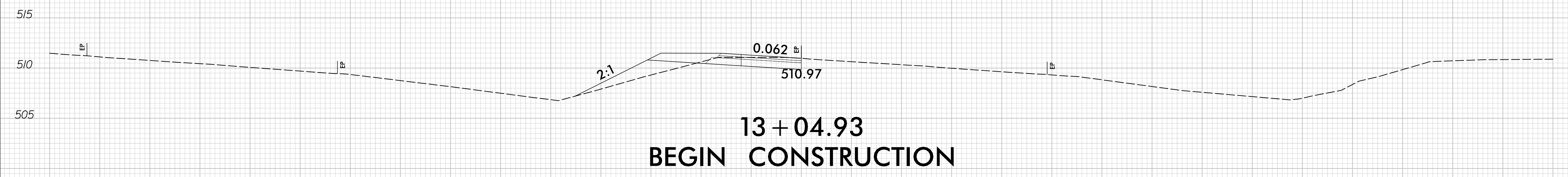
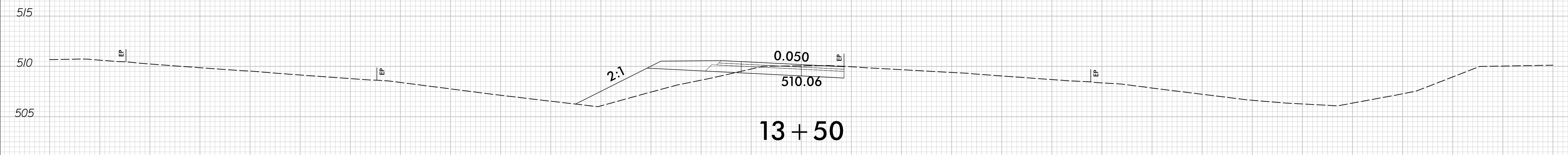
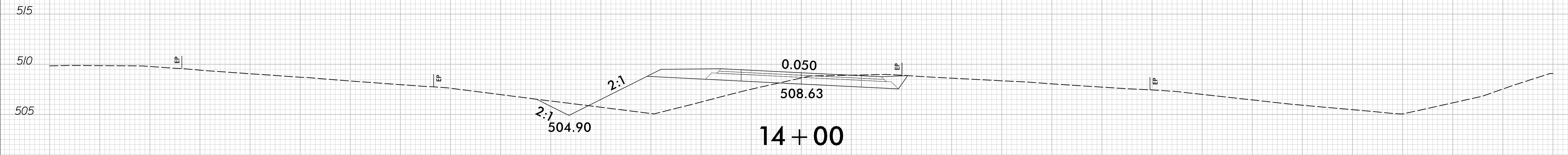

75 70 65 60 55 50 45 40 35 30 25 20 15 10 5 0 5 10 15 20 25 30 35 40 45 50 55 60 65 70 75

-XL-

75 70 65 60 55 50 45 40 35 30 25 20 15 10 5 0 5 10 15 20 25 30 35 40 45 50 55 60 65 70 75

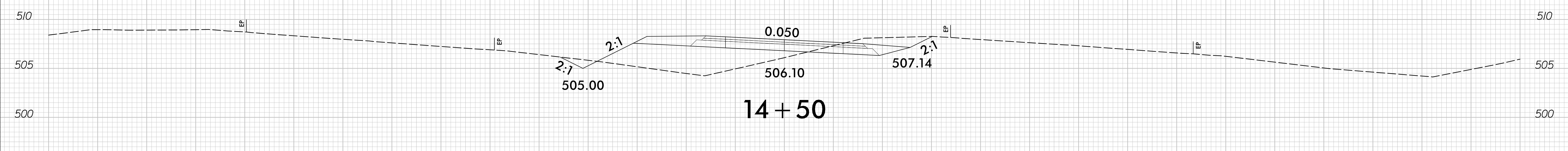
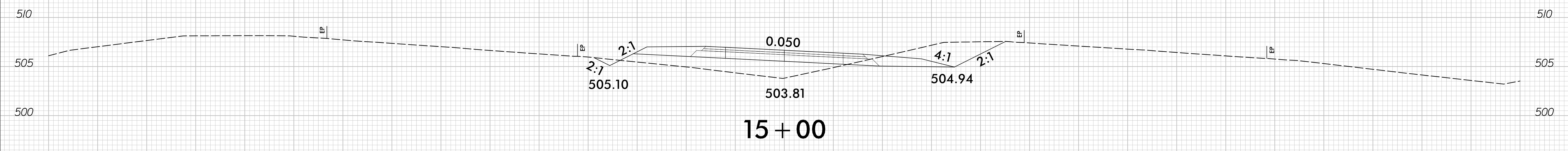
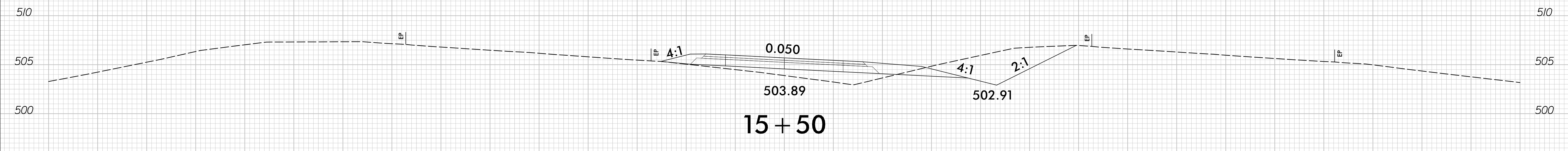
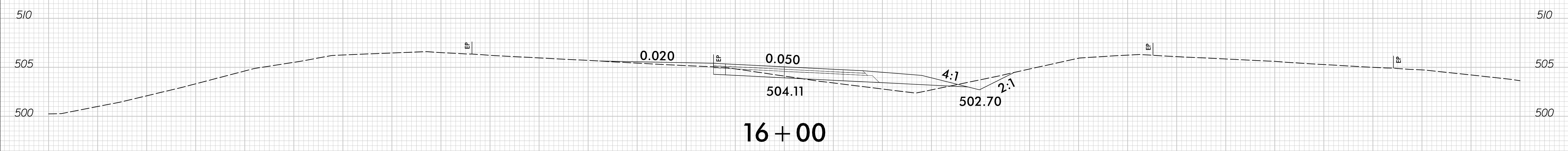

-XL-

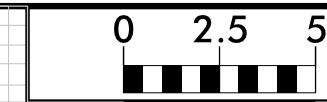

75 70 65 60 55 50 45 40 35 30 25 20 15 10 5 0 5 10 15 20 25 30 35 40 45 50 55 60 65 70 75

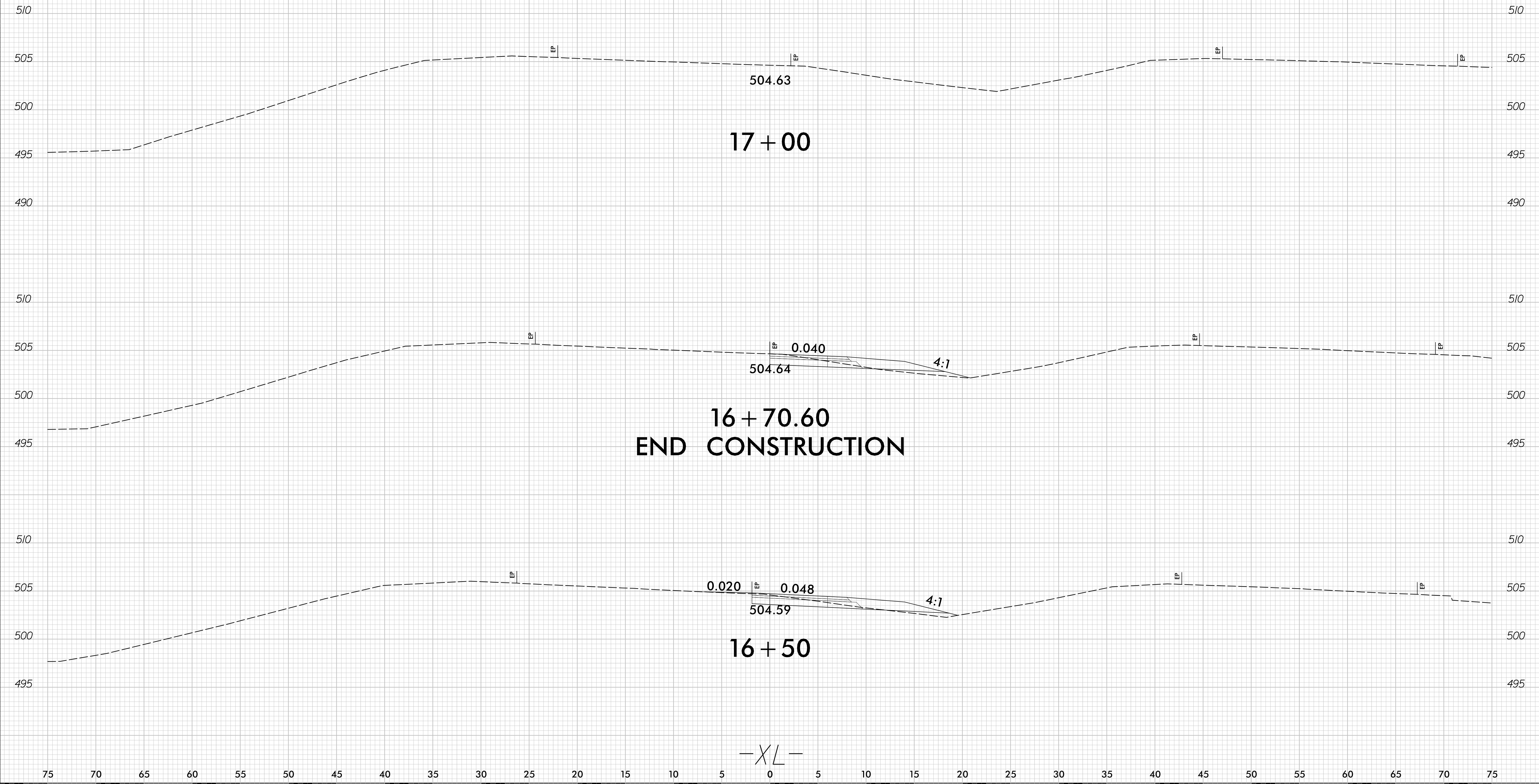

17 + 00

16 + 70.60
END CONSTRUCTION

16 + 50

-XL-

6/23/16

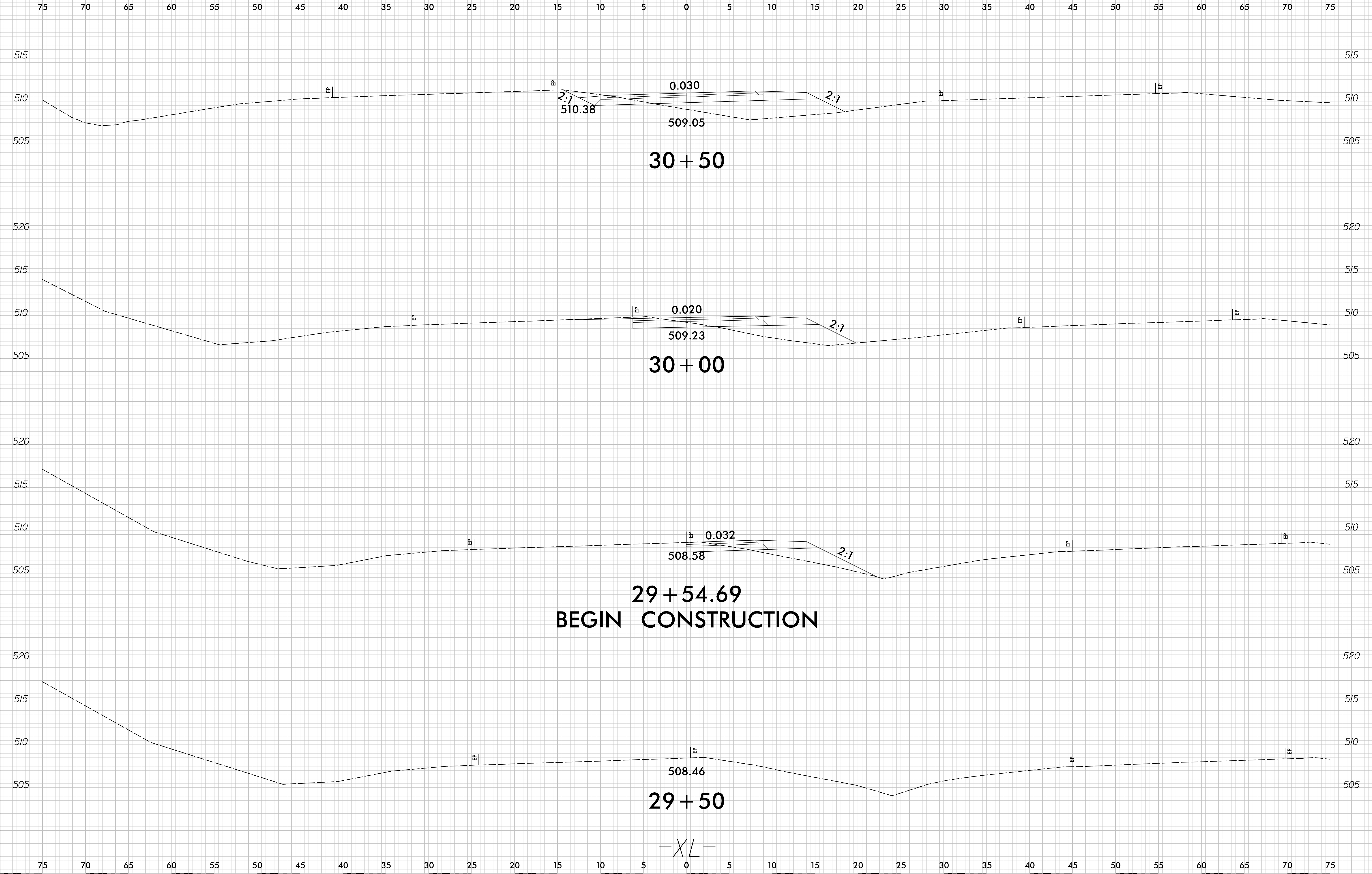

12/30/2021
I:\Projects\B5810\Corridor_Modeling\XL\B5810_rdy_xpl_xl.dgn
FloorUS

**29 + 54.69
BEGIN CONSTRUCTION**

29 + 50

—XL—

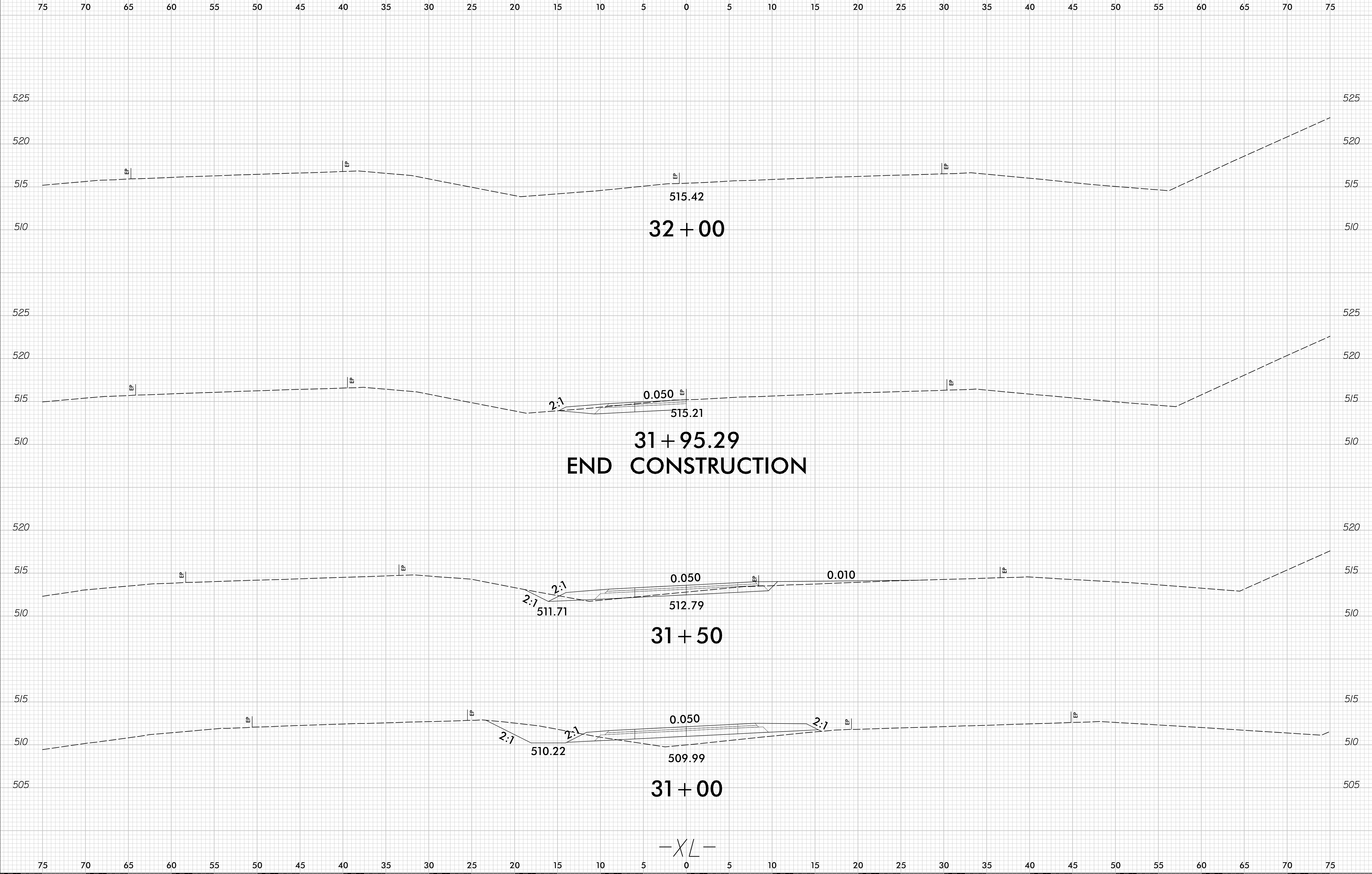

XL