

TYPICAL SECTION
(PROPOSED)

** FIELD VERIFY DIMENSION TO LONGITUDINAL DECK CONSTRUCTION JOINT (SEE NOTES)

NOTES:

SEE TRAFFIC MANAGEMENT PLANS FOR LANE WIDTHS, SEQUENCING, AND OTHER TRAFFIC CONTROL MEASURES FOR STAGING OF OVERLAY SURFACE PREPARATION AND PC PLACEMENT.

CONTRACTOR SHALL VERIFY THE PLAN DIMENSIONS TO THE DECK CONSTRUCTION JOINT AND USE THIS VERIFIED DIMENSION FOR SAWING THE LONGITUDINAL JOINT AFTER PLACEMENT OF THE OVERLAY.

THE LONGITUDINAL JOINT IN THE NEWLY PLACED OVERLAY SHALL BE SAWED PRIOR TO TRAFFIC BEING PLACED ON THE OVERLAY. THE JOINT SHALL BE CLEANED OF ALL DEBRIS BEFORE THE SEALANT IS APPLIED. THE JOINT SEALER MATERIAL SHALL CONFORM TO THE REQUIREMENTS OF TYPE SL LOW MODULUS SILICONE SEALANT.

VERIFY HORIZONTAL DIMENSION FROM C MEDIAN TO EXISTING LONGITUDINAL DECK CONSTRUCTION JOINT AT FILL FACE OF END BENTS AND C BENT.

THE CONTRACTOR SHALL ENSURE THAT THE SAWCUT FOLLOWS THE LINE OF THE EXISTING LONGITUDINAL CONSTRUCTION JOINT.

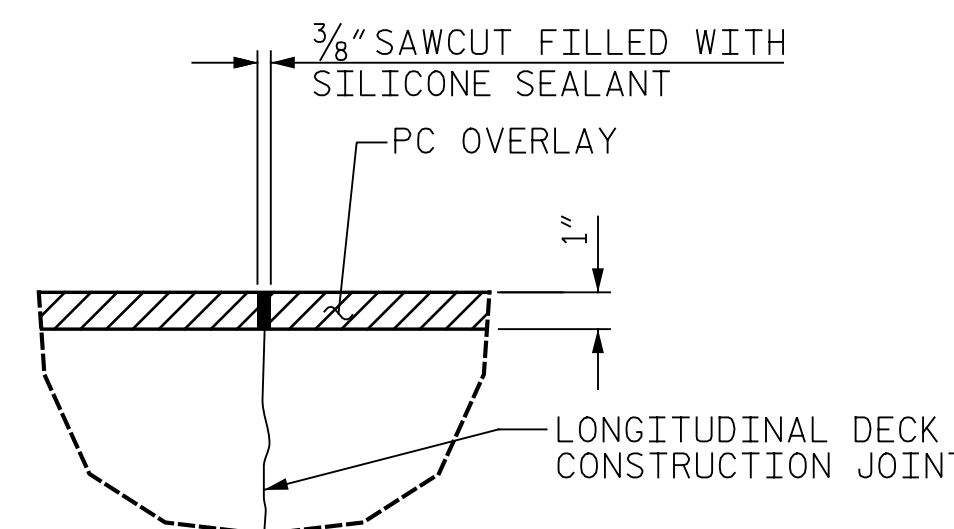

DETAIL A
(TYP. ALL LONGITUDINAL DECK CONSTRUCTION JOINTS)

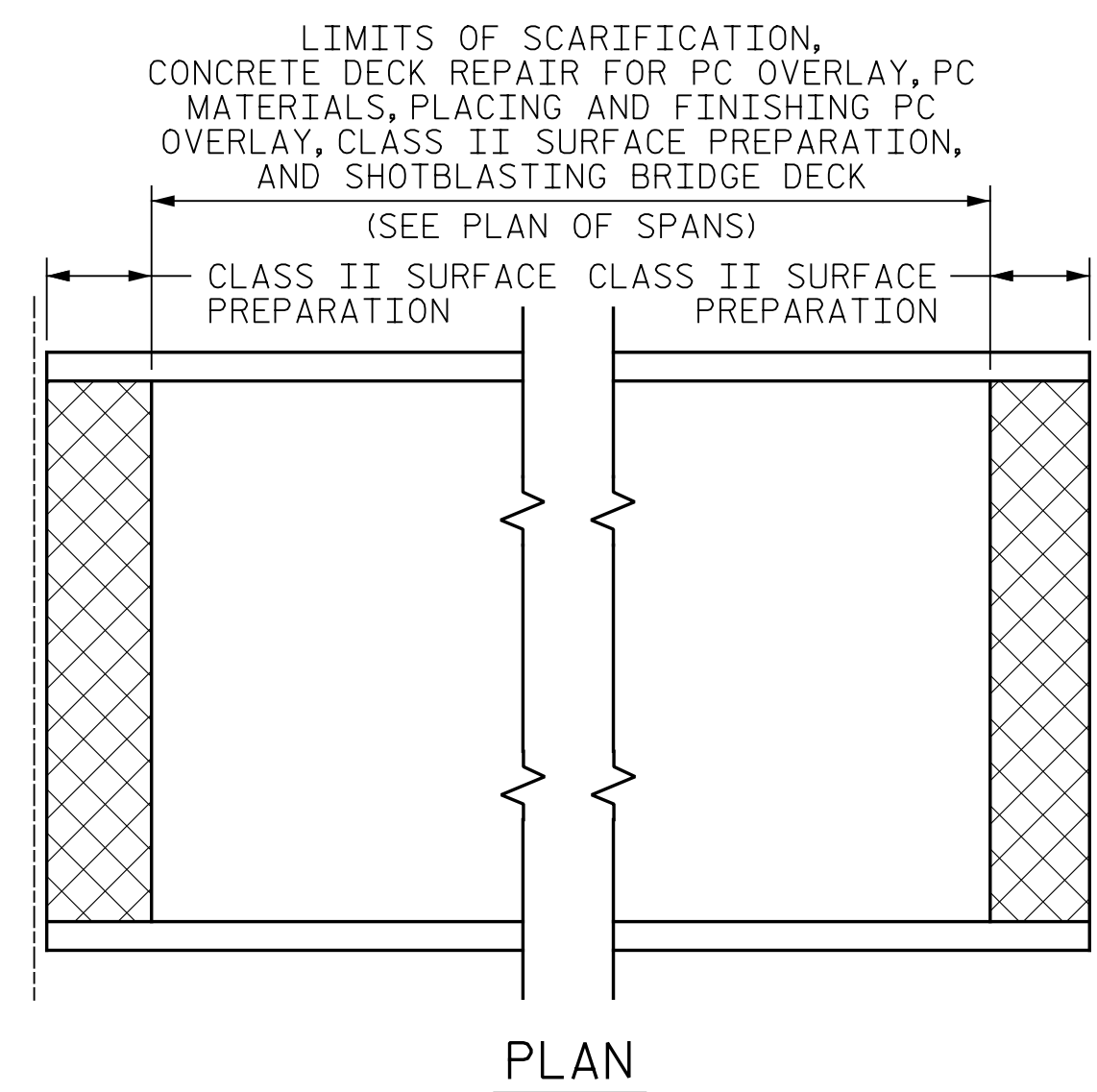

PLAN

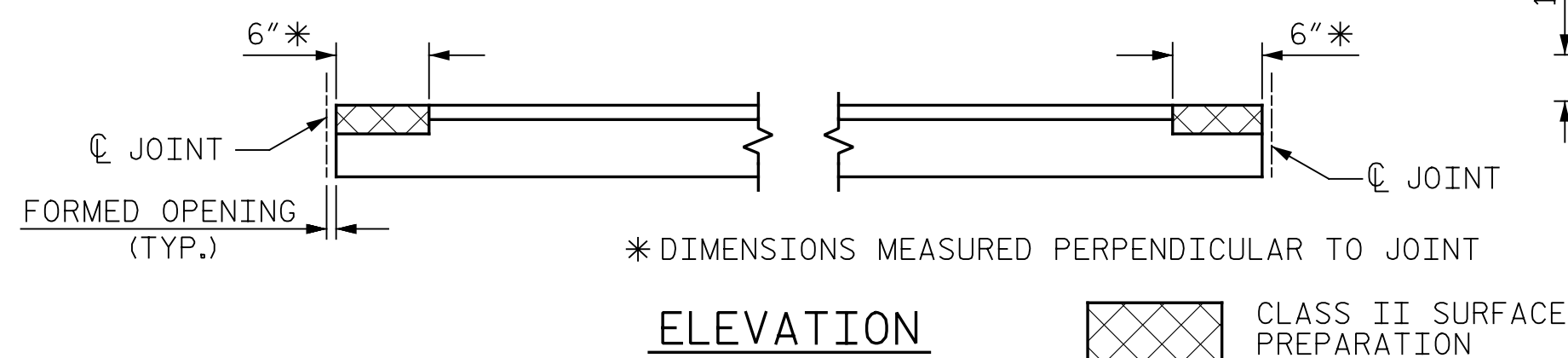

ELEVATION

PAY LIMITS FOR OVERLAY BID ITEMS

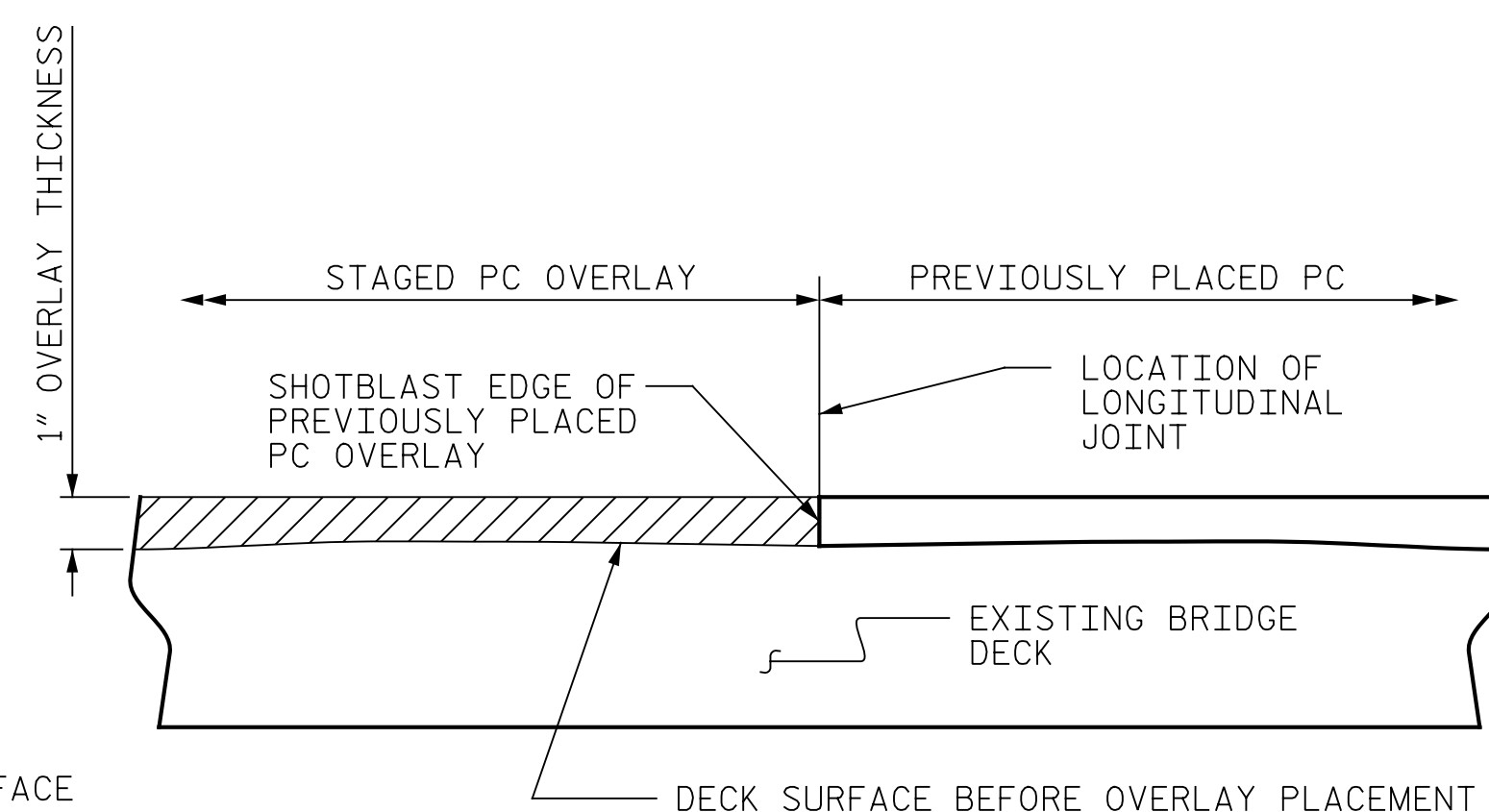

STAGED PC OVERLAY CONSTRUCTION JOINT

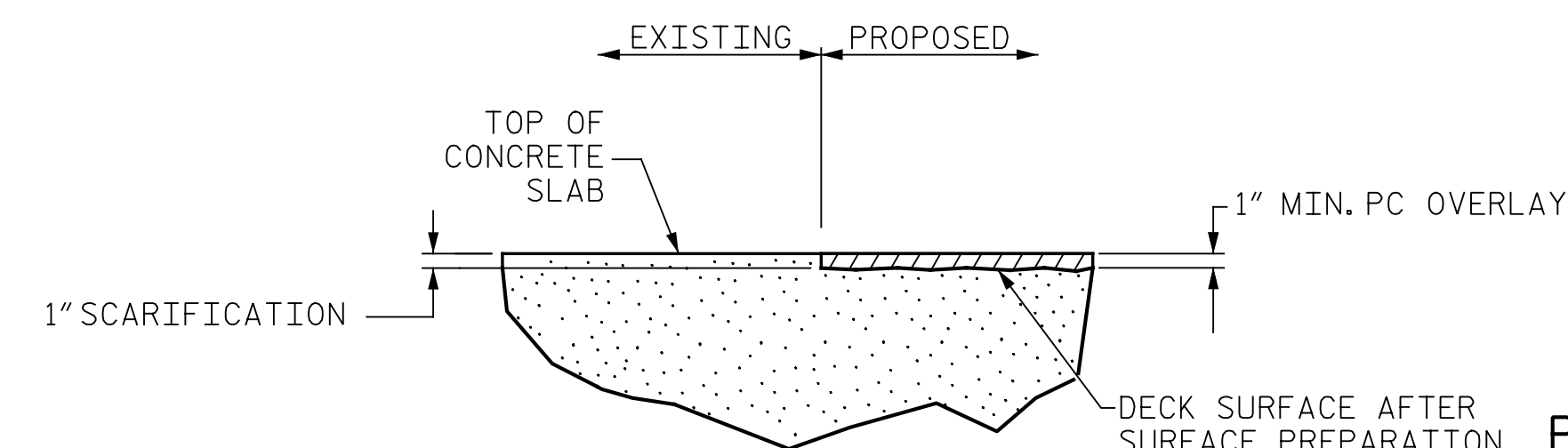

DETAIL FOR POLYMER CONCRETE OVERLAY

PROJECT NO. I-5997
WAKE COUNTY
BRIDGE NO. 910278



DocuSigned by:
Eric B. Nelson
11/22/2021
AC88082119074CD

STATE OF NORTH CAROLINA
DEPARTMENT OF TRANSPORTATION
RALEIGH
TYPICAL SECTION AND SURFACE PREPARATION DETAILS

REVISIONS						SHEET NO.
NO.	BY:	DATE:	NO.	BY:	DATE:	S-68
1			3			TOTAL SHEETS
2			4			81

DRAWN BY : J. MYA DATE : 08/2021
CHECKED BY : J. YANACCONI DATE : 09/2021
DESIGN ENGINEER OF RECORD : R. NELSON DATE : 09/2021

PLANS PREPARED BY:
Gannett Fleming
Excellence Delivered As Promised
One Glenwood Avenue
Suite 900
Raleigh, NC 27603
(919) 420-7660
NC Lic. No. F-0270

DOCUMENT NOT CONSIDERED FINAL UNLESS ALL SIGNATURES COMPLETED

p:\gfn\p\pw.bentley.com\gfn\p\pw-01\Documents\Projects\67945\Phase 003 - I-5997 Rehab\Structures\CAD\2.0 100% Plans\405_005_I5997_SMU_TS_910278_068 11/22/2021 9:24:26 AM pdf_color_gfct_FS.plt Rowan.pen.tbl