

p:\gfn\pw.bentley.com\gfn\p-w-01\Documents\Projects\67945\Phase 003 - I-5997 Rehab\Structures\CAD\2.0 100% Plans\403-015-15997\_SMU\_JT\_910263-910264\_040  
 1/12/2022 10:38:49 AM pdf\_color\_gfclt\_FS.plt Rowan.pen.tbl

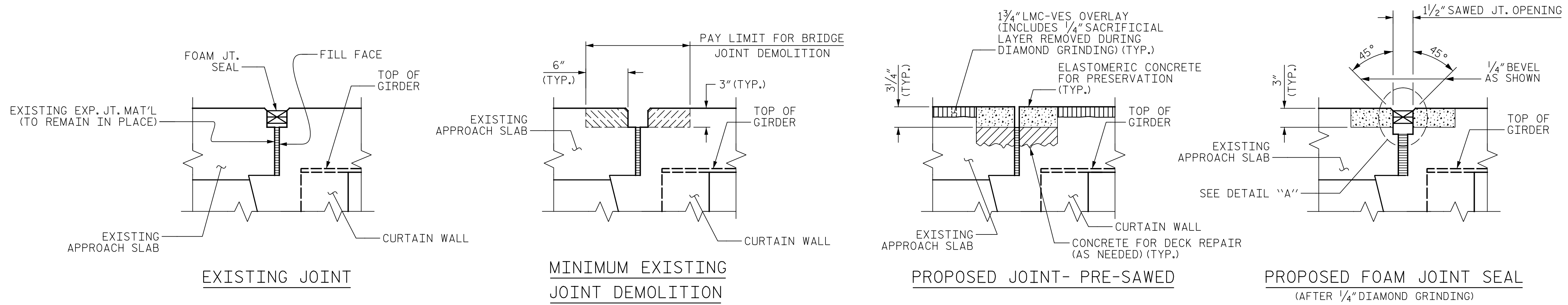

**SECTION A-A**

NOTE: RETAIN ALL EXISTING REINFORCING STEEL. CLEAN AND REPAIR AS REQ'D.

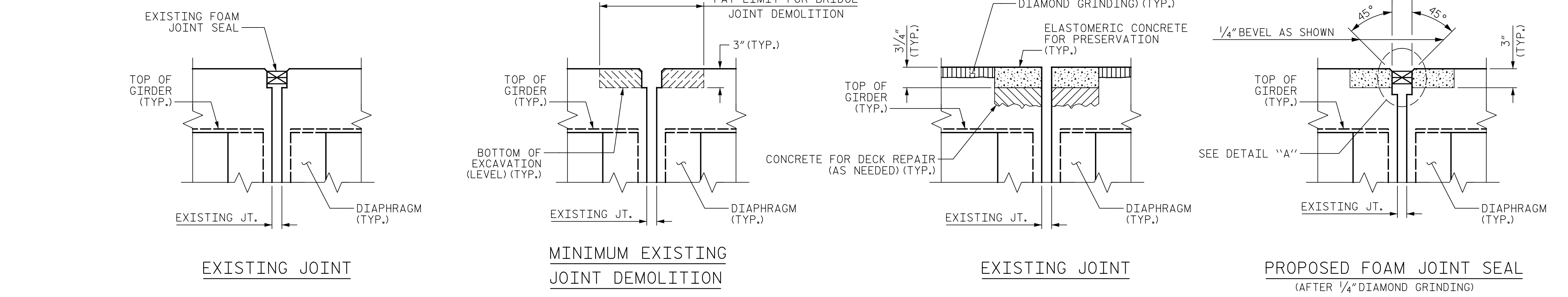

**SECTION B-B**

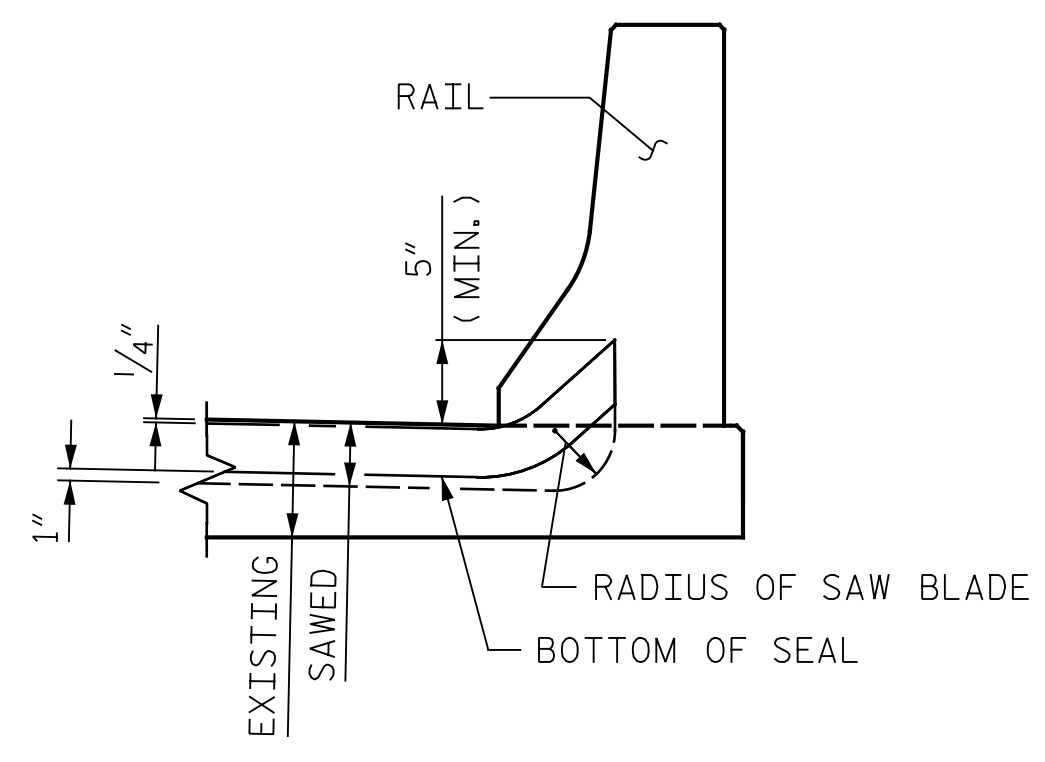
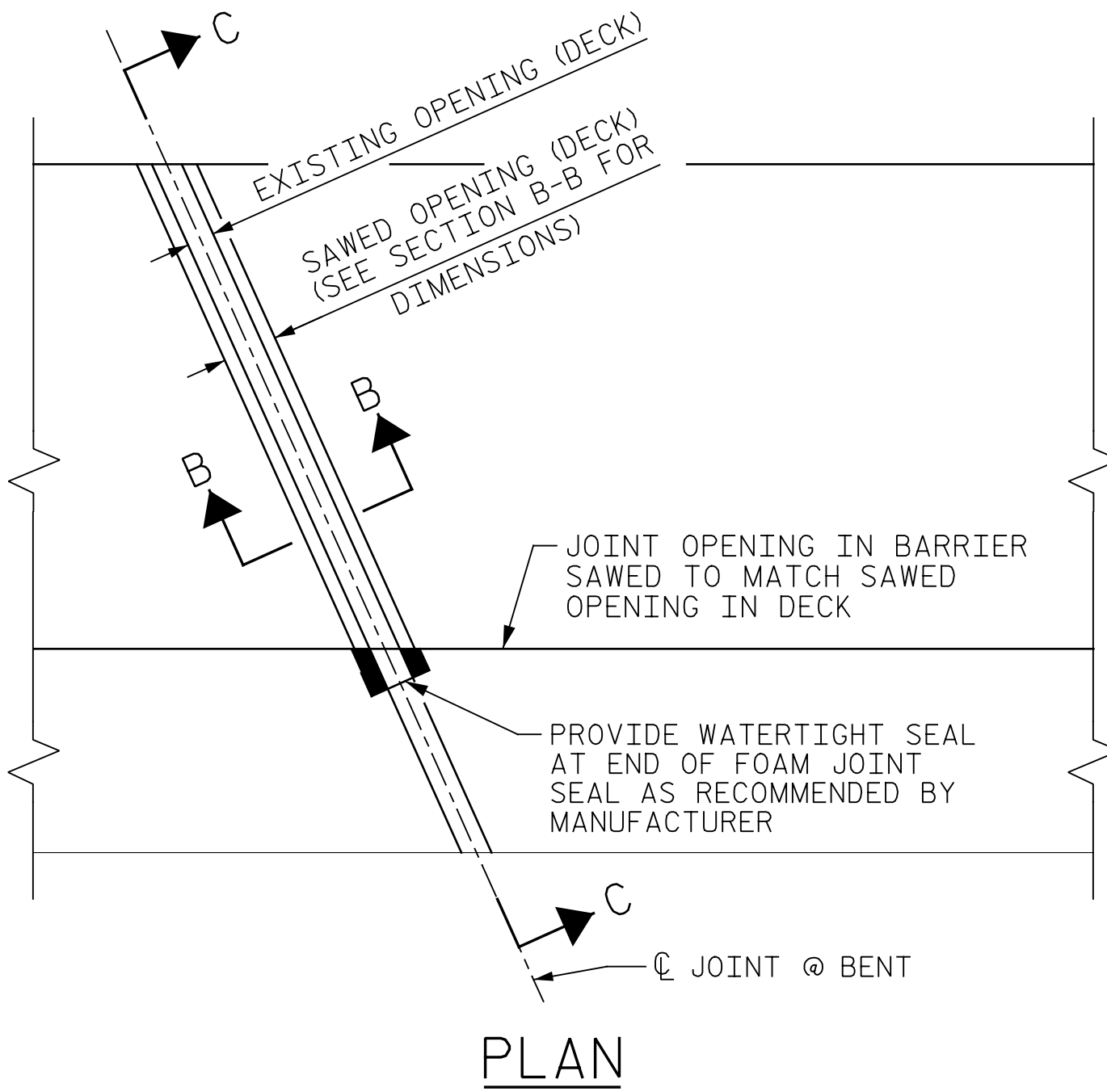

FOAM JOINT SEAL SHALL BE FACTORY FORMED OR CUT, HEAT WELDED AND TURNED UP PARALLEL TO SLOPED FACE OF CURB.

LOCATION	ELASTOMERIC CONCRETE FOR PRESERVATION	FOAM JOINT SEALS FOR PRESERVATION
	CU. FT.	LIN. FT.
END BENT 1	46.6	176.5
BENT 1	47.0	177.5
BENT 2	47.4	179.0
BENT 3	47.8	180.5
BENT 4	48.2	182.0
END BENT 2	48.6	183.5
* TOTAL	285.6	1079.0

\* BASED ON MINIMUM BLOCKOUT SHOWN

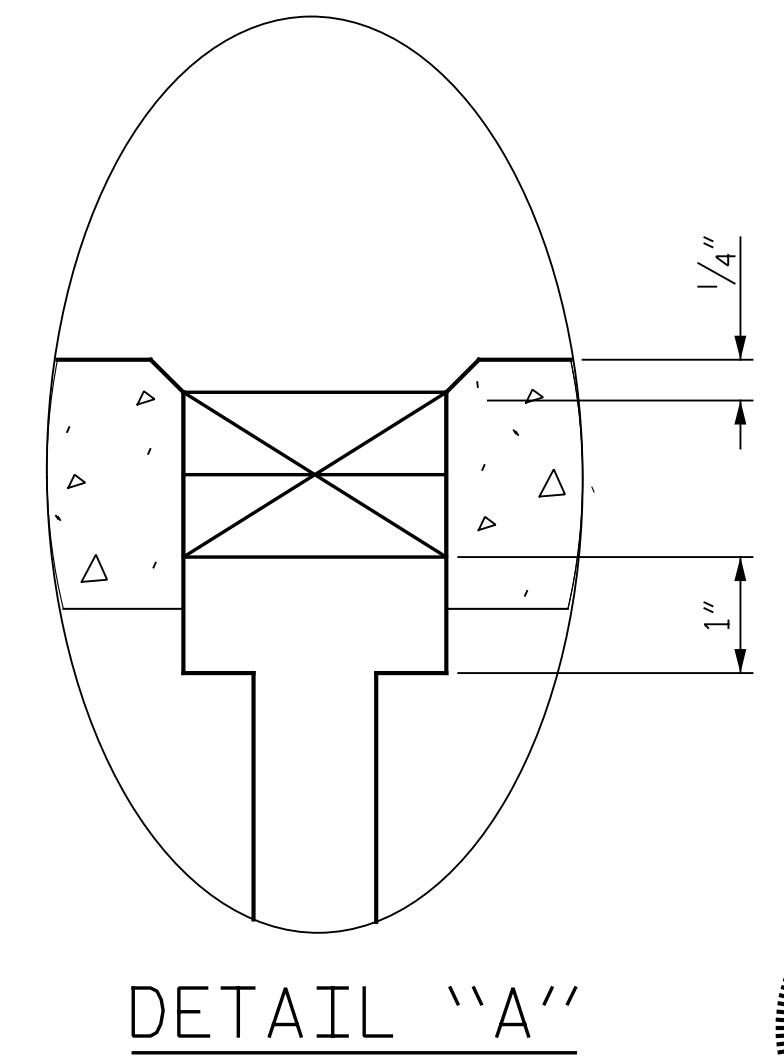

**NOTES:**

FINAL JOINT SEALS SHALL NOT BE INSTALLED UNTIL THE OVERLAY OR SEALANT WORK IS COMPLETE.

THE CONTRACTOR SHALL FIELD VERIFY THE EXISTING JOINT MATERIAL OPENING PRIOR TO ORDERING JOINT SEAL MATERIAL. IF THE ACTUAL JOINT OPENING VARIES FROM THE OPENING INDICATED IN THE DETAILS BY MORE THAN 1/4", NOTIFY THE ENGINEER.

THE MANUFACTURER IS TO PROVIDE THE NOMINAL UNCOMPRESSED SEAL WIDTH OF THE FOAM JOINT SEAL FOR THE SIZE OF THE OPENING ON THE PLANS AND ACCOMMODATE THE MINIMUM EXPANSION SHOWN ON THE PLANS.

FOAM JOINTS SHALL BE INSTALLED AS PER THE MANUFACTURER'S RECOMMENDATIONS.

THE CONTRACTOR SHALL TAKE CARE DURING JOINT REHAB OPERATIONS NOT TO DROP ANY MATERIAL BELOW THE BRIDGE WITHOUT PROTECTIVE DEVICES BELOW TO CATCH THE MATERIAL. ANY MATERIAL THAT FALLS BELOW THE BRIDGE SHALL BE CONTAINED, REMOVED AND DISPOSED OF BY THE CONTRACTOR AT NO EXTRA COST TO THE DEPARTMENT. IF THE ENGINEER DETERMINES THAT THE PROTECTIVE DEVICES ARE NOT ADEQUATE OR NOT BEING EMPLOYED, THE WORK SHALL BE SUSPENDED UNTIL ADEQUATE PROTECTION IS PROVIDED.

THE CONTRACTOR WILL NOT BE PERMITTED TO FORM THE JOINT IN LIEU OF SAWING THE JOINT. THE INSTALLED FOAM JOINTS SHALL BE WATERTIGHT.

THE CONTRACTOR SHALL SAW CUT TO A NOMINAL DEPTH OF 1/2" BUT REINFORCING STEEL SHALL NOT BE DAMAGED. CONTRACTOR SHALL REMOVE SURFACE CONCRETE TO VERIFY THAT SAWCUT DEPTH WILL NOT DAMAGE EXISTING REINFORCING STEEL.

QUANTITIES SHOWN IN THE ELASTOMERIC CONCRETE FOR PRESERVATION TABLE ARE BASED ON THE MINIMUM JOINT DEMOLITION SHOWN.

FOR EXCAVATION BELOW THE BOTTOM OF PLANNED JOINT DEMOLITION, CONCRETE FOR DECK REPAIR SHALL BE PLACED IN THE EXCAVATED AREA TO THE ELEVATION AT THE BOTTOM OF THE PROPOSED ELASTOMERIC CONCRETE FOR PRESERVATION HEADERS SHOWN.

FOR BRIDGE JOINT DEMOLITION, SEE SPECIAL PROVISIONS.

FOR CONCRETE FOR DECK REPAIR, SEE SPECIAL PROVISIONS.

FOR ELASTOMERIC CONCRETE FOR PRESERVATION, SEE SPECIAL PROVISIONS.

FOR FOAM JOINT SEALS FOR PRESERVATION, SEE SPECIAL PROVISIONS.

PROJECT NO. I-5997  
WAKE COUNTY  
 BRIDGE NO. 910263 & 910264

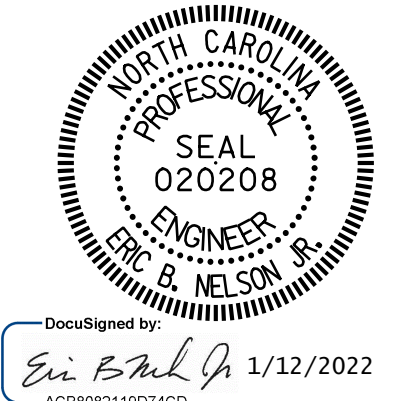

DocuSigned by:  
 Eric B. Nelson  
 1/12/2022

STATE OF NORTH CAROLINA  
 DEPARTMENT OF TRANSPORTATION  
 RALEIGH

**JOINT DETAILS**

DRAWN BY: J. MYA DATE: 09/2021  
 CHECKED BY: J. YANACCONI DATE: 09/2021  
 DESIGN ENGINEER OF RECORD: R. NELSON DATE: 09/2021

PLANS PREPARED BY:  
**Gannett Fleming**  
 Excellence Delivered As Promised

One Glenwood Avenue  
 Suite 900  
 Raleigh, NC 27603  
 (919) 420-7660  
 NC Lic. No. F-0270

DOCUMENT NOT CONSIDERED FINAL UNLESS ALL SIGNATURES COMPLETED

REVISIONS						SHEET NO.
NO.	BY:	DATE:	NO.	BY:	DATE:	S-40
1			3			TOTAL SHEETS
2			4			82