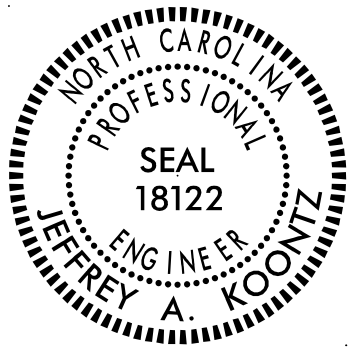

**This electronic collection of documents is provided
for the convenience of the user
and is Not a Certified Document –**

**The documents contained herein were originally issued
and sealed by the individuals whose names and license
numbers appear on each page, on the dates appearing
with their signature on that page.**

**This file or an individual page
shall not be considered a certified document.**

TIP NO. BR-0044	SHEET NO. PMP-1
APPROVED: <u>Jeffrey A. Koontz</u> DATE: 3/3/2020	
	
DOCUMENT NOT CONSIDERED FINAL UNLESS ALL SIGNATURES COMPLETED	

**STATE OF NORTH CAROLINA
DEPARTMENT OF TRANSPORTATION**

**PAVEMENT MARKING PLAN
ROCKINGHAM COUNTY**

LOCATION: BRIDGE NO.168 ON NC 14 / NC 87
(N. VAN BUREN RD) OVER SMITH RIVER

T.I.P.: BR-0044

CONTRACT: C204393

INDEX

SHEET NO.	DESCRIPTION
PMP-01	PAVEMENT MARKING PLAN TITLE AND SCHEDULE SHEET, STD DWGS, NOTES
PMP-2 THRU PMP-4	PAVEMENT MARKING DETAILS

ROADWAY STANDARD DRAWING

THE FOLLOWING ROADWAY STANDARDS AS APPEAR IN "ROADWAY STANDARD DRAWINGS" - PROJECT SERVICES UNIT - N.C. DEPARTMENT OF TRANSPORTATION - RALEIGH, N.C., DATED JANUARY 2018 ARE APPLICABLE TO THIS PROJECT AND BY REFERENCE HEREBY ARE CONSIDERED A PART OF THESE PLANS:

STD. NO.	TITLE
1205.01	PAVEMENT MARKINGS - LINE TYPES AND OFFSETS
1205.02	PAVEMENT MARKINGS - TWO-LANE AND MULTILANE ROADWAYS
1205.12	PAVEMENT MARKINGS - BRIDGES
1250.01	RAISED PAVEMENT MARKERS - INSTALLATION SPACING
1253.01	RAISED PAVEMENT MARKERS - SNOWPLOWABLE
1251.01	RAISED PAVEMENT MARKERS - PERMANENT AND TEMPORARY
1261.01	GUARDRAIL AND BARRIER DELINEATORS - INSTALLATION SPACING
1261.02	GUARDRAIL AND BARRIER DELINEATORS - TYPES AND MOUNTING
1261.02	GUARDRAIL AND BARRIER DELINEATORS - TYPES AND MOUNTING
1261.02	GUARDRAIL END DELINEATION

GENERAL NOTES

THE FOLLOWING GENERAL NOTES APPLY AT ALL TIMES FOR THE DURATION OF THE CONSTRUCTION PROJECT, EXCEPT WHEN OTHERWISE NOTED IN THE PLAN, OR DIRECTED BY THE ENGINEER.

A) INSTALL PAVEMENT MARKINGS AND PAVEMENT MARKERS ON THE FINAL SURFACE AS FOLLOWS:

ROAD NAME	MARKING	MARKER
NC 14 / NC 87	THERMOPLASTIC	SNOWPLOWABLE
NC 14 / NC 87 BRIDGE	POLYUREA	RAISED

B) TIE PROPOSED PAVEMENT MARKING LINES TO EXISTING PAVEMENT MARKING LINES

C) REMOVE/REPLACE ANY CONFLICTING/DAMAGED PAVEMENT MARKINGS AND MARKERS

FINAL PAVEMENT MARKING SCHEDULE

SYMBOL	DESCRIPTION	SYMBOL	DESCRIPTION
	THERMOPLASTIC		MARKERS
T1	WHITE EDGELINE, (4", 90 MIL)	MA	PERMANENT RAISED / YELLOW & YELLOW
T12	10 FT. YELLOW SKIP, (4", 90 MIL)	ME	SNOWPLOWABLE / YELLOW & YELLOW
	POLYUREA		
V1	WHITE EDGELINE, (4")		
V12	YELLOW DOUBLE CENTERLINE (4")		

PLAN SUBMITTED TO:

DAVID STUTTS, PE PROJECT ENGINEER

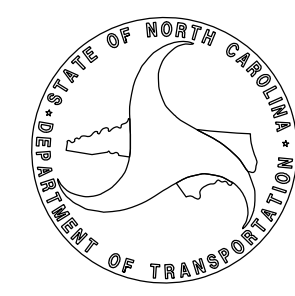

PLAN PREPARED BY: **AECOM**

701 Corporate Center Drive, Suite 475
Raleigh, NC 27607
(919) 854-6200 • (919) 854-6259 (FAX)

JEFFREY KOONTZ, PE

PROJECT ENGINEER

RADHA ATTALURI, PE

PROJECT DESIGNER

TIP NO. BR - 0044	SHEET NO. PMP - 2
DESIGNED BY: <i>Jeffrey A. Kootz</i> APPROVED: <i>Jeffrey A. Kootz</i> DATE: 3/3/2020	
DOCUMENT NOT CONSIDERED FINAL UNLESS ALL SIGNATURES COMPLETED	
AECOM <small>NC FIRM LICENSE No. F-0342 701 Corporate Center Drive, Suite 475 Raleigh, NC 27603 (919) 854-6200 • (919) 854-6259 FAX</small>	

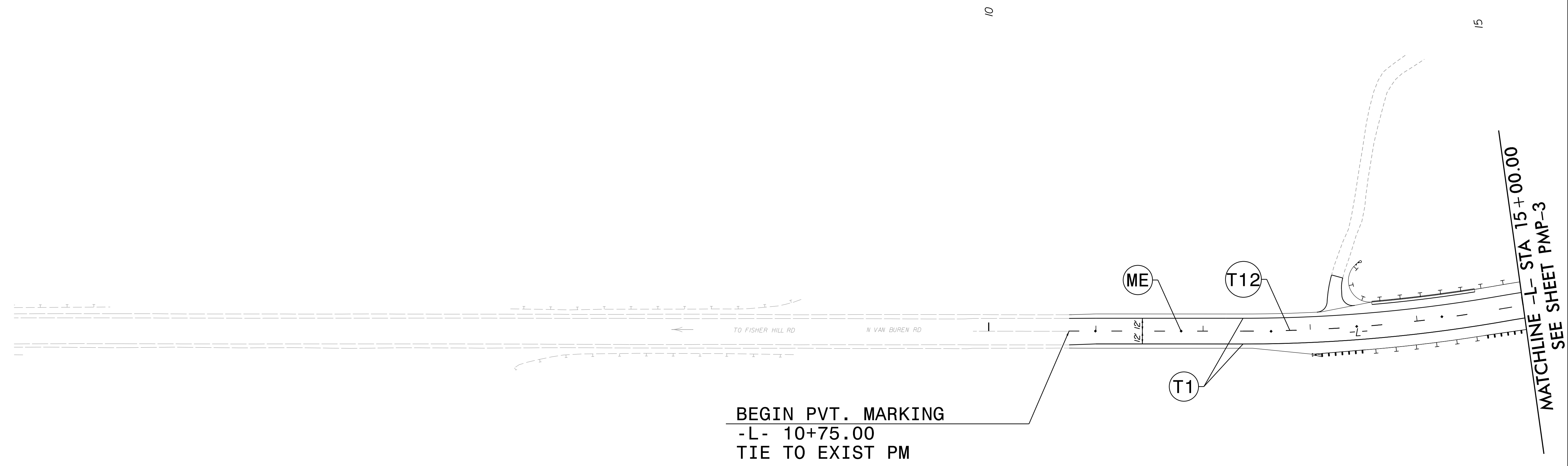
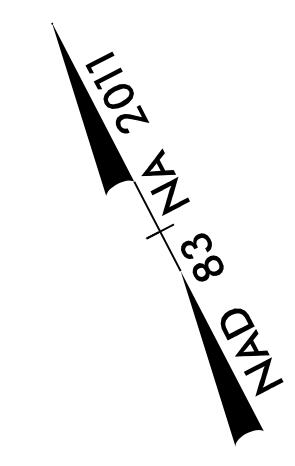

**FINAL PAVEMENT
MARKING SCHEDULE**

<u>SYMBOL</u>	<u>DESCRIPTION</u>	<u>SYMBOL</u>	<u>DESCRIPTION</u>
	THERMOPLASTIC		MARKERS
T1	WHITE EDGELINE, (4", 90 MIL)	MA	PERMANENT RAISED / YELLOW & YELLOW
T12	10 FT. YELLOW SKIP, (4", 90 MIL)	ME	SNOWPLOWABLE / YELLOW & YELLOW
	POLYUREA		
V1	WHITE EDGELINE, (4")		
V12	YELLOW DOUBLE CENTERLINE (4")		

PAVEMENT MARKING DETAIL

3/3/2020
 \\usnsvf000\DATA\Projects\Projects\60571085 - BR-0044\900_CAD_GIS\910_CAD\70_NCD01_TIP\Traffic\BR-0044\TCP\BR00044_pmp_psh02.dgn
 radha.ctf@ur

TIP NO. BR - 0044	SHEET NO. PMP - 3
APPROVED: <i>Jeffrey A. Koozitz</i> <small>DESIGNED BY: Jeffrey A. Koozitz</small>	
DATE: 3/3/2020	
DOCUMENT NOT CONSIDERED FINAL UNLESS ALL SIGNATURES COMPLETED	

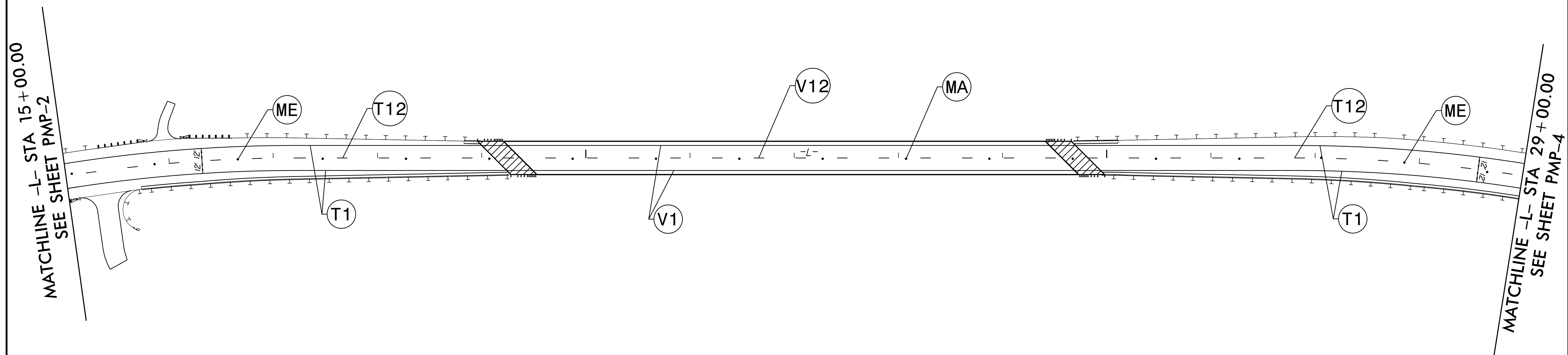
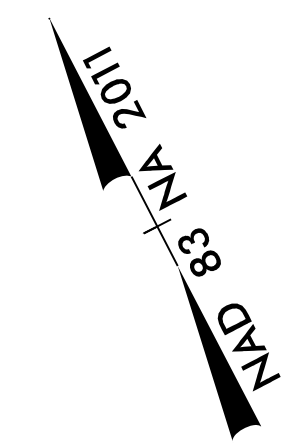

**FINAL PAVEMENT
MARKING SCHEDULE**

SYMBOL	DESCRIPTION	SYMBOL	DESCRIPTION
	THERMOPLASTIC		MARKERS
T1	WHITE EDGELINE, (4", 90 MIL)	MA	PERMANENT RAISED / YELLOW & YELLOW
T12	10 FT. YELLOW SKIP, (4", 90 MIL)	ME	SNOWPLOWABLE / YELLOW & YELLOW
	POLYUREA		
V1	WHITE EDGELINE, (4")		
V12	YELLOW DOUBLE CENTERLINE (4")		

PAVEMENT MARKING DETAIL

3/3/2020
 \\usnsvf000\DATA\Projects\Projects\60571085 - BR-0044\900_CAD_GIS\910_CAD\70_NCDOT_TIP\Traffic\BR-0044\TCP\BR0044_pmp_psh03.dgn
 radha.ctf@ur

TIP NO. BR - 0044	SHEET NO. PMP - 4
APPROVED: <i>Jeffrey A. Koovitz</i> <small>DESIGNED BY: Jeffrey A. Koovitz</small>	
DATE: 3/3/2020	
DOCUMENT NOT CONSIDERED FINAL UNLESS ALL SIGNATURES COMPLETED	
AECOM	
<small>NC FIRM LICENSE No. F-0342 701 Corporate Center Drive, Suite 475 Raleigh, NC 27607 (919) 854-6200 • (919) 854-6259 FAX</small>	

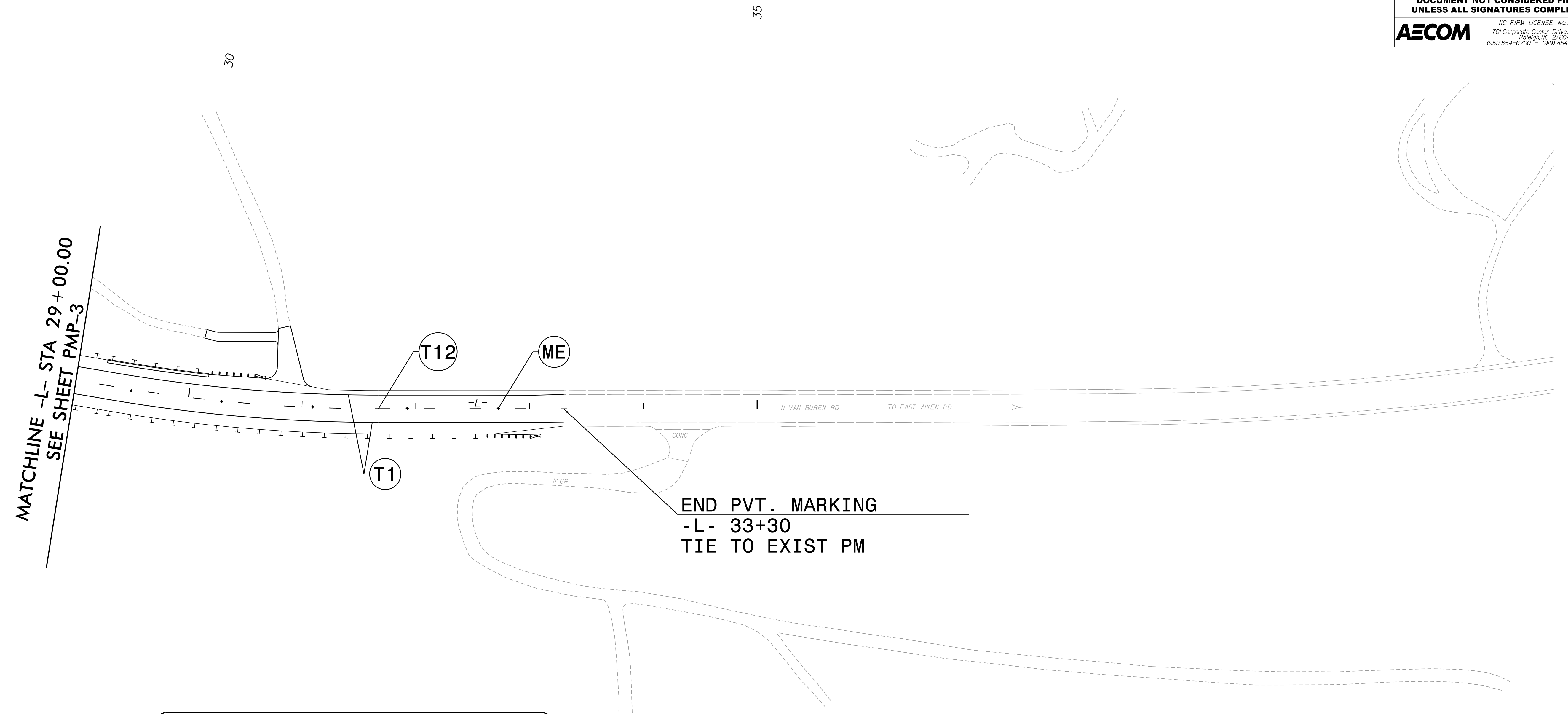
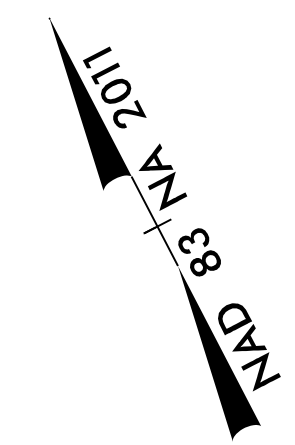

**FINAL PAVEMENT
MARKING SCHEDULE**

SYMBOL	DESCRIPTION	SYMBOL	DESCRIPTION
THERMOPLASTIC			
T1	WHITE EDGELINE, (4", 90 MIL)	MA	PERMANENT RAISED / YELLOW & YELLOW
T12	10 FT. YELLOW SKIP, (4", 90 MIL)	ME	SNOWPLOWABLE / YELLOW & YELLOW
POLYUREA			
V1	WHITE EDGELINE, (4")		
V12	YELLOW DOUBLE CENTERLINE (4")		

PAVEMENT MARKING DETAIL

3/3/2020
 \\usnsvf000\DATA\Projects\Projects\60571085 - BR-0044\900_CAD_GIS\910_CAD\70_NCD01_TIP\Traffic\BR-0044\TCP\BR0044_pmp_psh04.dgn
 radha.ctf@ur1