

DATE: 3/29/2019  
TIME: 2:28:00 PM

USER: Bin.Tan@AECOM.COM  
DRAWING: R:\Structures\04 Drawings\01\_001\_BR0044\_LSMU\_BRD.dgn

ESTIMATED QUANTITIES		
BRIDGE @ STA. 21+97.00 -L-	RIP RAP CLASS II (2'-0" THICK)	GEOTEXTILE FOR DRAINAGE
	TONS	SQUARE YARDS
END BENT 1	1946	2162
END BENT 2	1075	1194

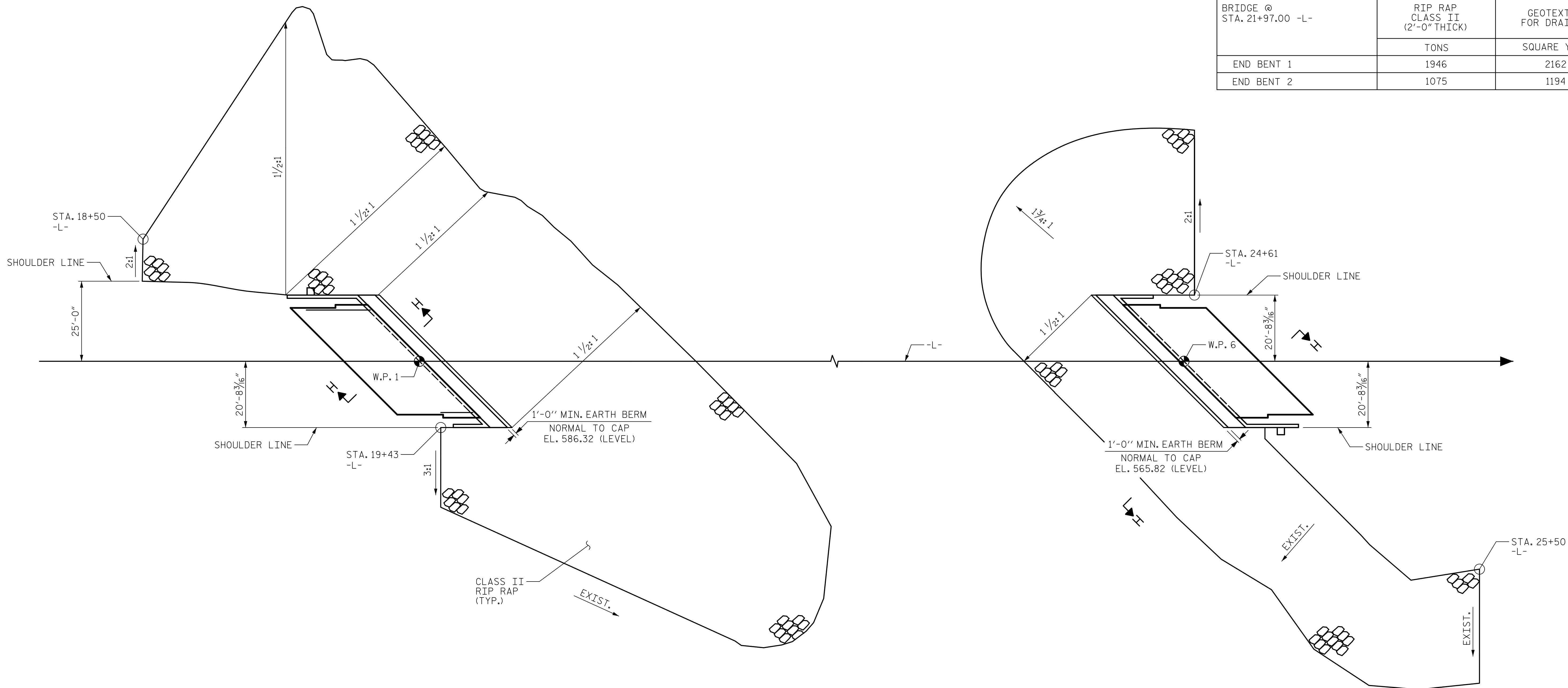

@ END BENT 1

@ END BENT 2

PLAN

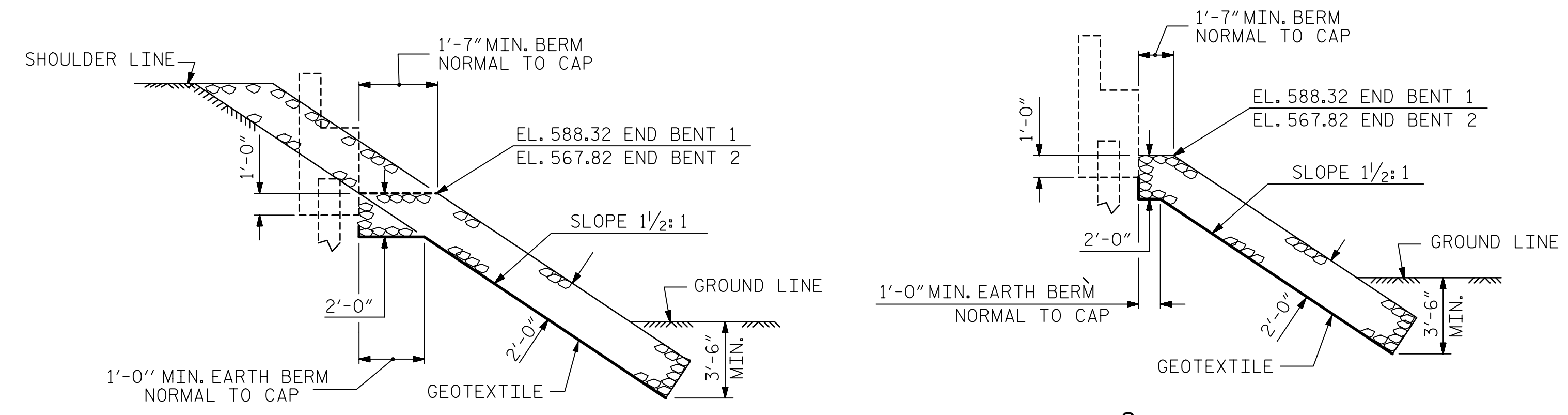

SECTION H-H

SECTION  
BERM RIP RAPPED

PROJECT NO. BR-0044  
ROCKINGHAM COUNTY  
STATION: 21+97.00 -L-

**AECOM**  
AECOM TECHNICAL SERVICES OF NC, INC.  
5438 WADE PARK BOULEVARD, SUITE 200  
RALEIGH, NC 27607  
(919) 854-6200  
www.aecom.com  
AECOM License No. F-0342

Seal: NORTH CAROLINA PROFESSIONAL ENGINEER  
SEAL  
041343  
GREGORY R. COX  
5/15/2019

REVISIONS						SHEET NO. S-37
NO.	BY:	DATE:	NO.	BY:	DATE:	
1			3			TOTAL SHEETS 39
2			4			

DRAWN BY : A. JIANG	DATE : 11/2019
CHECKED BY : G.R. COLS	DATE : 11/2019
DESIGNED BY : S. NATARAJAN	DATE : 11/2019
DESIGN CHECKED BY : G.R. COLS	DATE : 11/2019

DOCUMENT NOT CONSIDERED  
FINAL UNLESS ALL  
SIGNATURES COMPLETED