

DATE: 3/29/2019
TIME: 2:26:55 PM

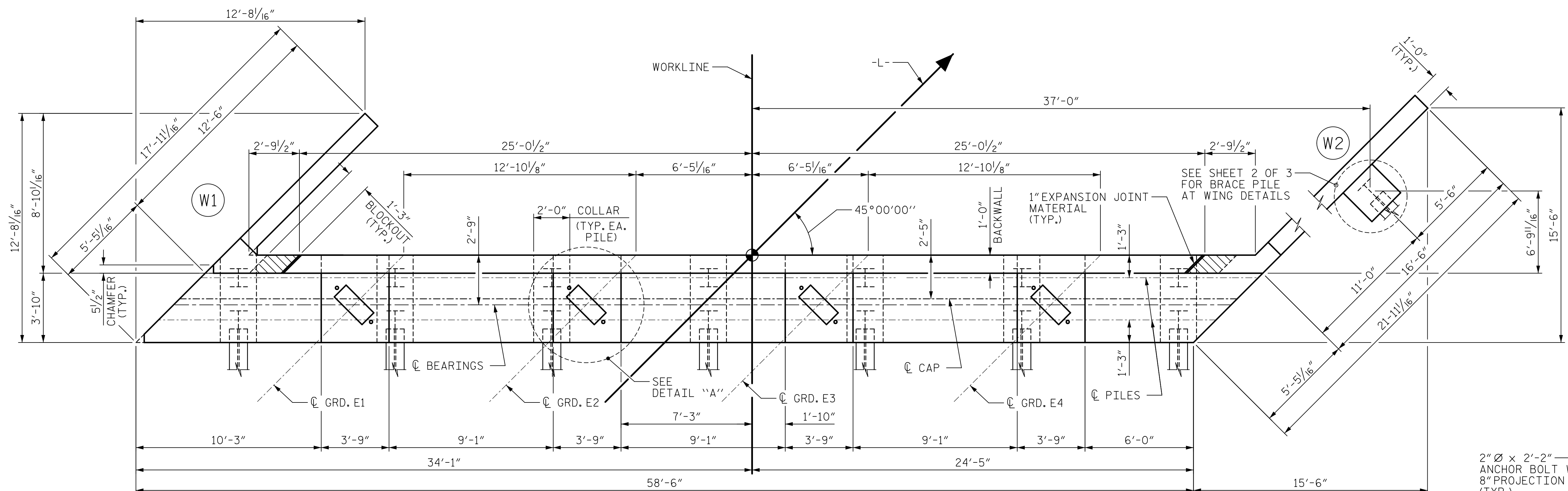

PLAN

NOTES:

STIRRUPS AND #4 "U" BARS IN CAP MAY BE SHIFTED SLIGHTLY TO CLEAR ANCHOR BOLTS.

#5V1 BARS SHALL BE PLACED 2" CLEAR FROM THE BOTTOM OF CAP.

THE TOP SURFACE AREAS OF THE END BENT CAP SHALL BE CURED IN ACCORDANCE WITH THE STANDARD SPECIFICATIONS EXCEPT THAT THE MEMBRANE CURING COMPOUND METHOD SHALL NOT BE USED.

FOR WING DETAILS, SEE SHEET 2 OF 3.

BACKWALL SHALL BE PLACED BEFORE APPLYING PROTECTIVE COATING.

FOR SECTION A-A, SECTION B-B, PILE SPLICE DETAILS, AND TEMPORARY DRAINAGE DETAILS, SEE SHEET 3 OF 3.

THE CONCRETE IN THE SHADED AREA OF THE WING SHALL BE POURED AFTER THE JOINT BETWEEN THE DECK AND APPROACH SLAB HAS BEEN SAWED AND THE BARRIER RAIL IS CAST IF SLIP FORMING IS USED.

THE TOP SURFACE OF THE CAP EXCEPT THE BRIDGE SEAT BUILDUPS SHALL BE SLOPED TRANSVERSELY FROM THE FILL FACE TO THE BACK FACE AT A RATE OF 2%.

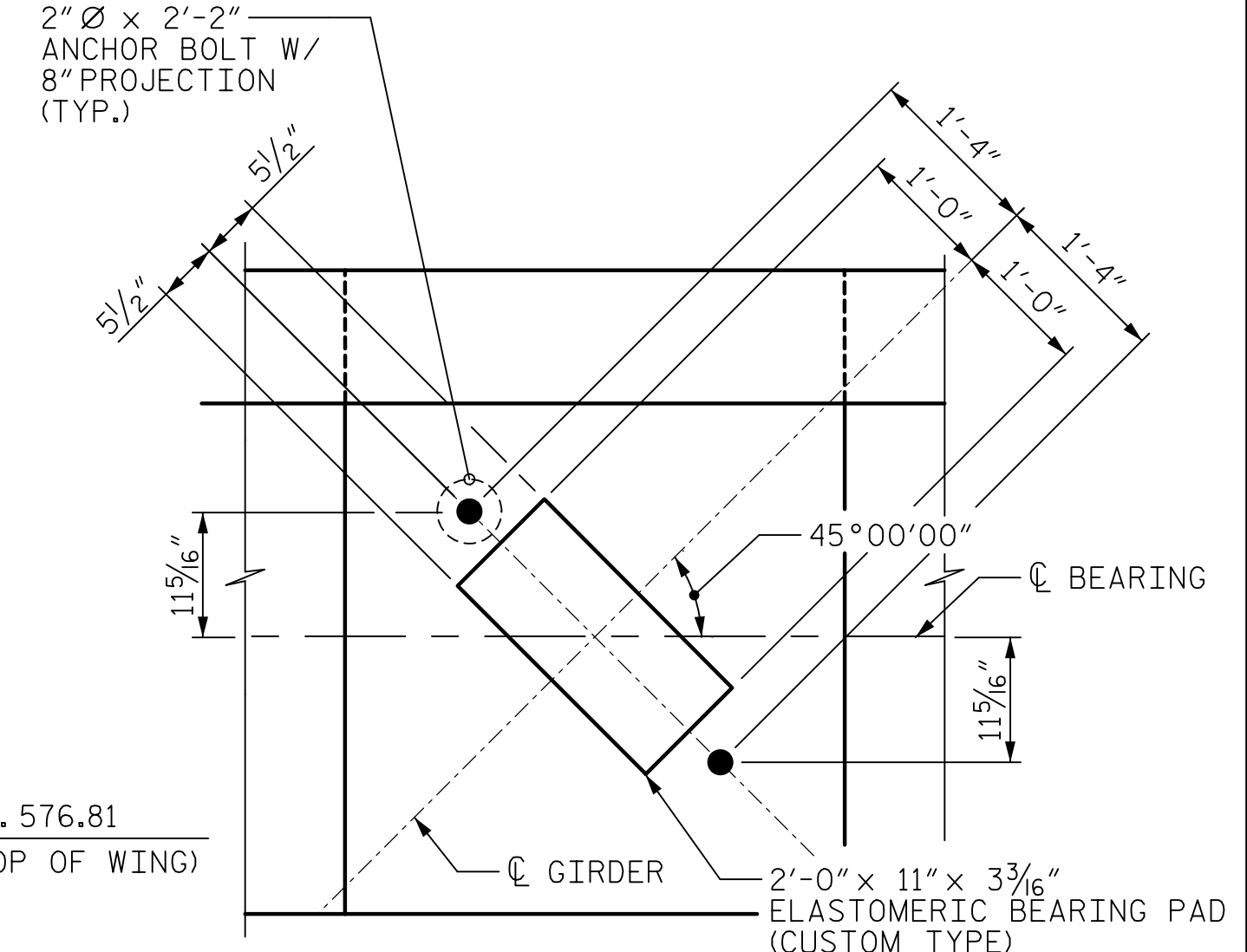

DETAIL "A"

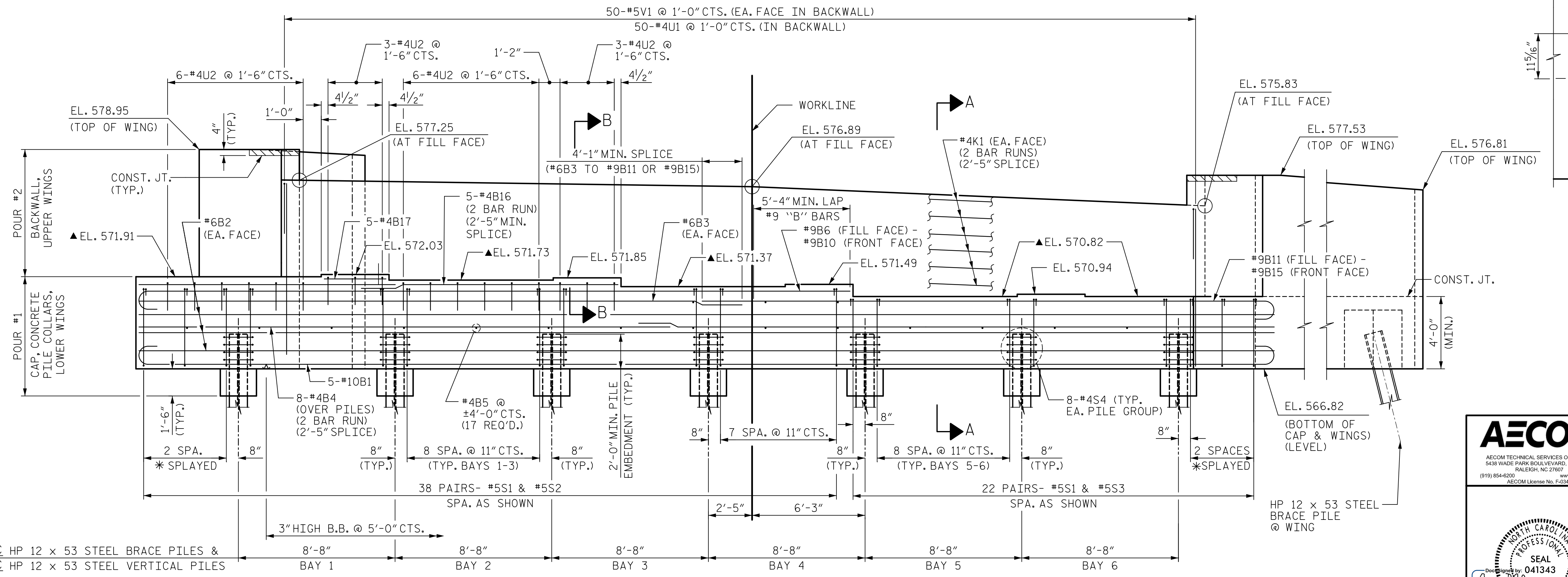

ELEVATION

PROJECT NO. BR-0044
 ROCKINGHAM COUNTY
 STATION: 21+97.00 -L-

SHEET 1 OF 3



STATE OF NORTH CAROLINA
 DEPARTMENT OF TRANSPORTATION
 RALEIGH

SUBSTRUCTURE

END BENT 2

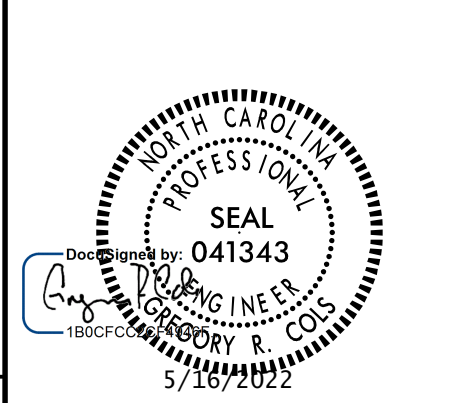

REVISIONS						SHEET NO.	
NO.	BY:	DATE:	NO.	BY:	DATE:	S-34	
1			3			TOTAL SHEETS	
2			4			39	

DRAWN BY : D.R. DRUM DATE : 11/2019
 CHECKED BY : G.R. COLS DATE : 11/2019
 DESIGNED BY : H.T. ROSEMOND DATE : 11/2019
 DESIGN CHECKED BY : S. NATARAJAN DATE : 11/2019

▲ FOR LOCATION OF ELEVATIONS BETWEEN BRIDGE SEAT BUILDUPS, SEE SECTION A-A ON SHEET 3.

* SEE "SPRAYED BAR DETAIL" ON SHEET 3 OF 3

DOCUMENT NOT CONSIDERED FINAL UNLESS ALL SIGNATURES COMPLETED

USER: BinJambalagack
 DSN: R:\Structures\04 Drawings\01_D067_BR0044_S1M1_E20.dgn