

DATE: 4/15/2022  
TIME: 3:45:59 PM

### ELEVATIONS AT BENTS

BENT	W.P. STATION	BRIDGE SEAT ELEV.				COLUMN AND DRILLED PIER ELEV.		
		ELEV. A	ELEV. B	ELEV. C	ELEV. D	ELEV. E	ELEV. F	ELEV. G
1	20+43.00	588.51	588.33	587.97	587.42	582.92	550.42	518.92
2	21+56.00	583.99	583.81	583.45	582.90	578.40	541.15	518.90
3	22+69.00	579.47	579.29	578.93	578.38	573.88	541.13	521.88
4	23+82.00	574.95	574.77	574.41	573.86	569.36	548.11	505.86

### TABLE OF DIMENSIONS

BENT	"A"	"B"	"C"
1	31'-6"	32'-6"	16'-3"
2	22'-3"	37'-3"	18'-9"
3	19'-3"	32'-9"	16'-6"
4	42'-3"	21'-3"	10'-9"

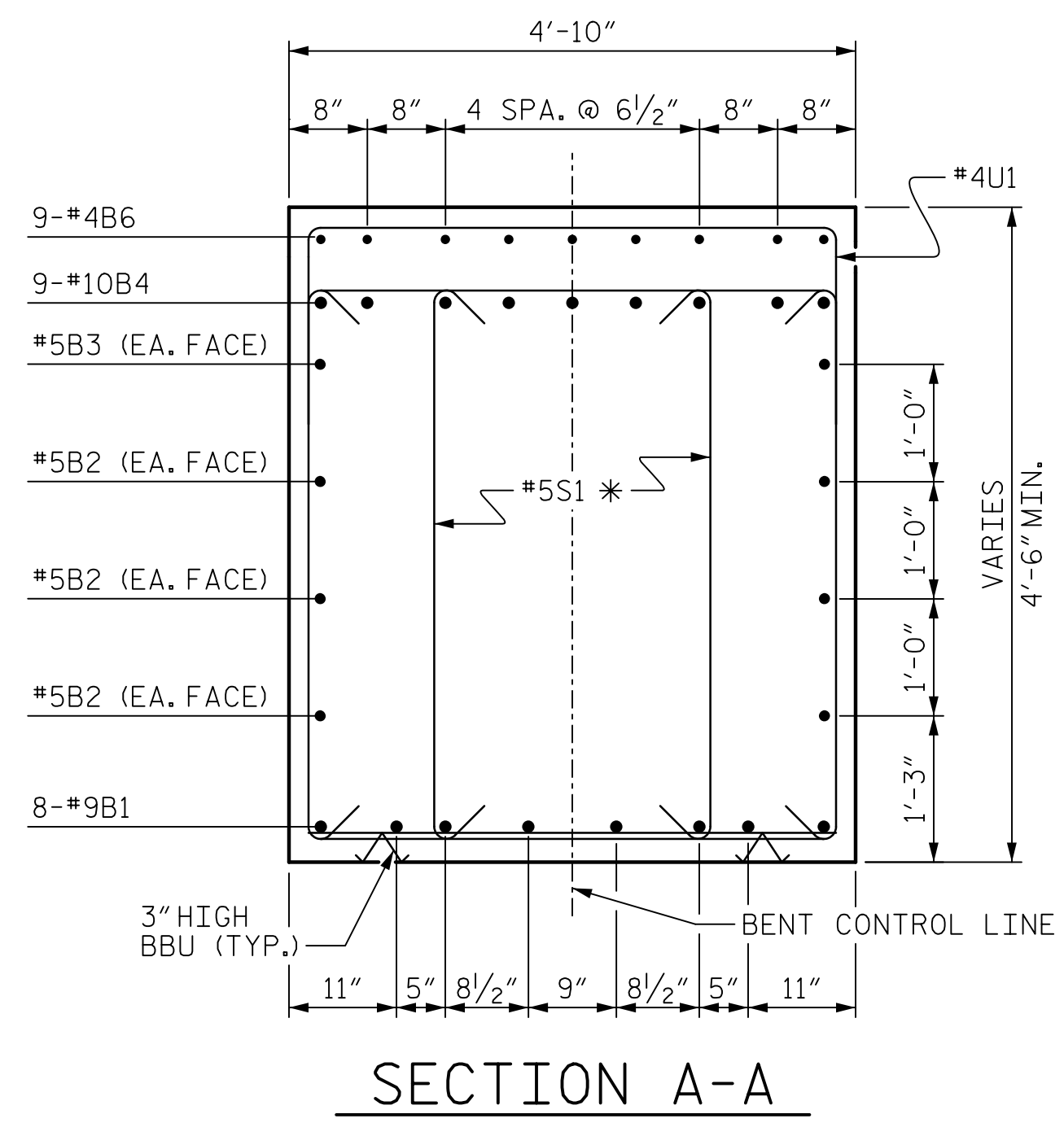

SECTION A-A

\*INVERT ALTERNATE PAIR OF STIRRUPS BETWEEN COLUMNS

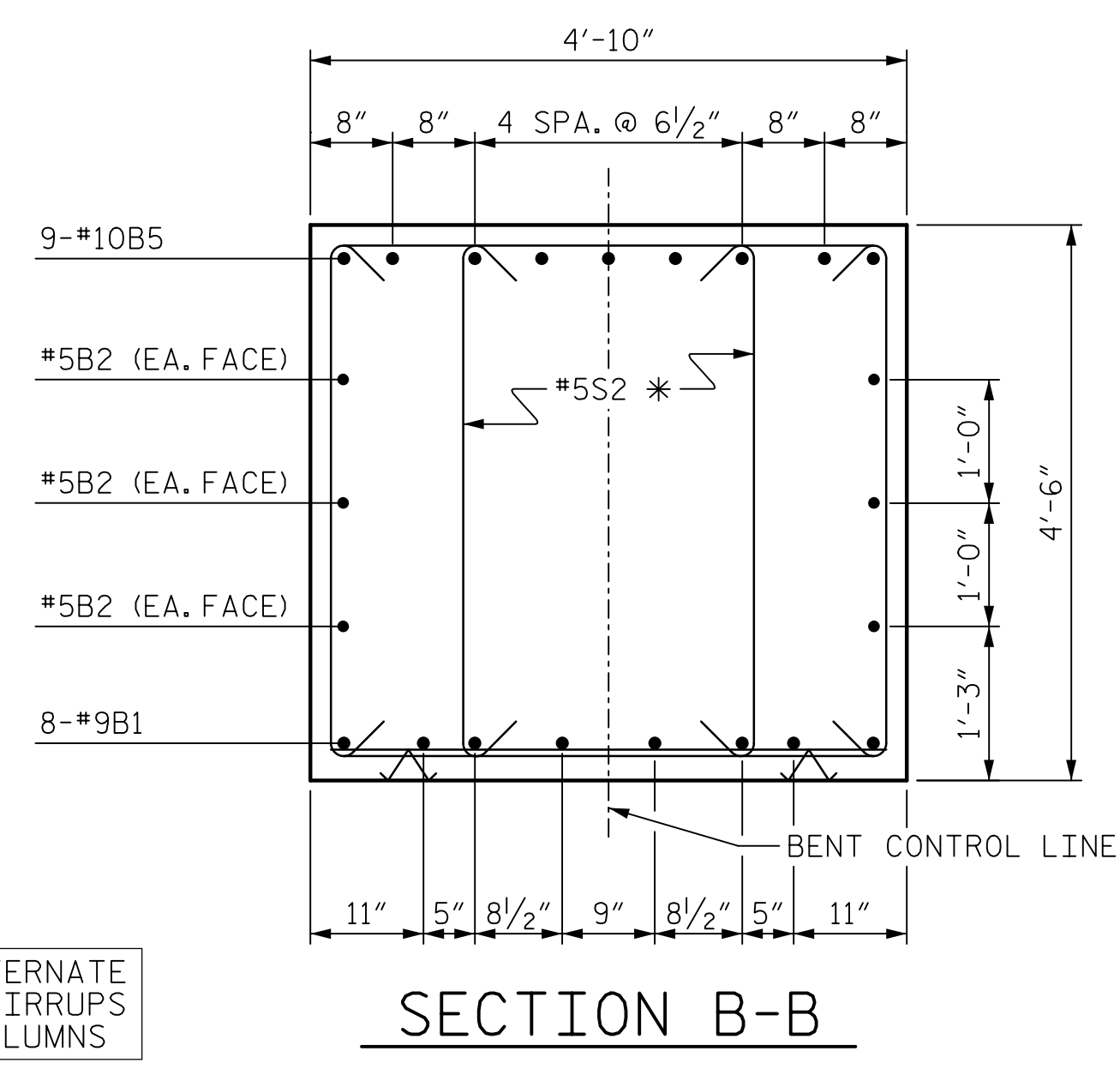

SECTION B-B

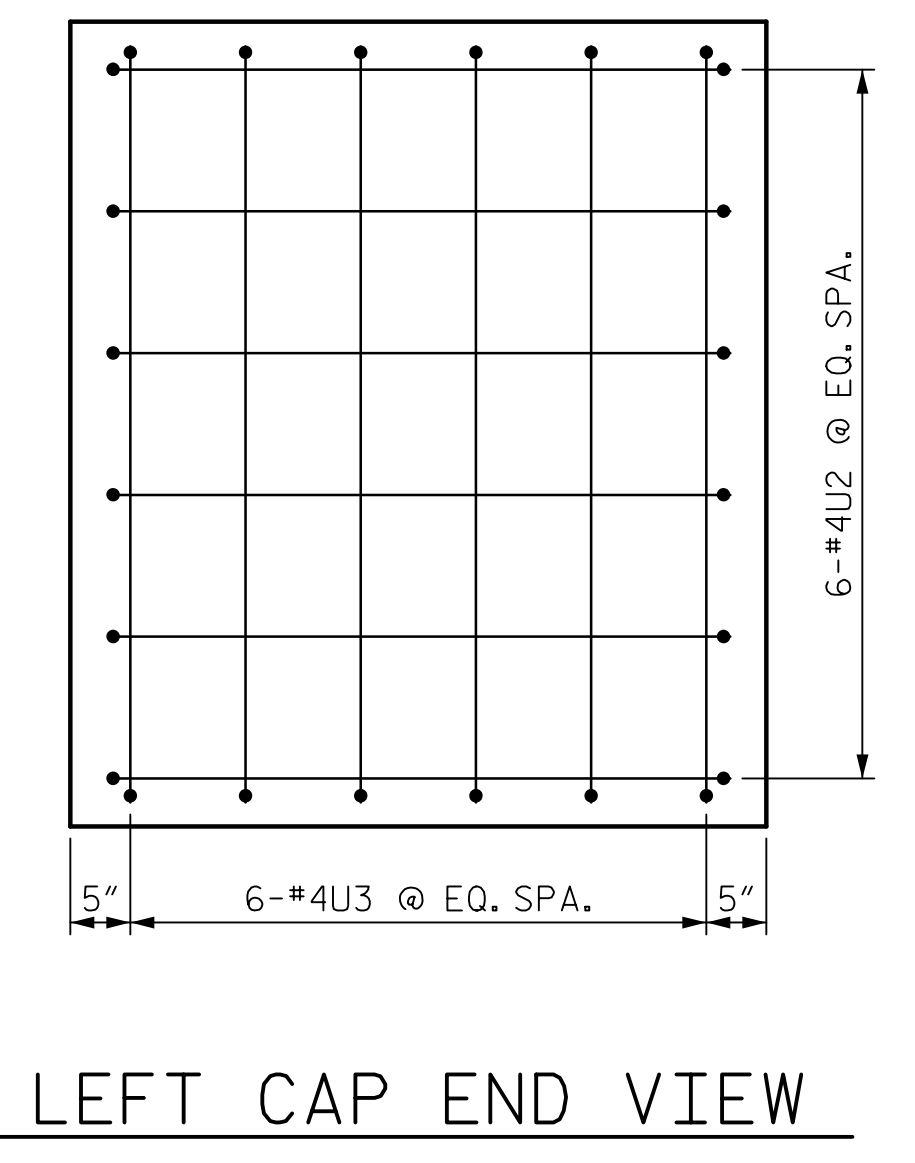

LEFT CAP END VIEW

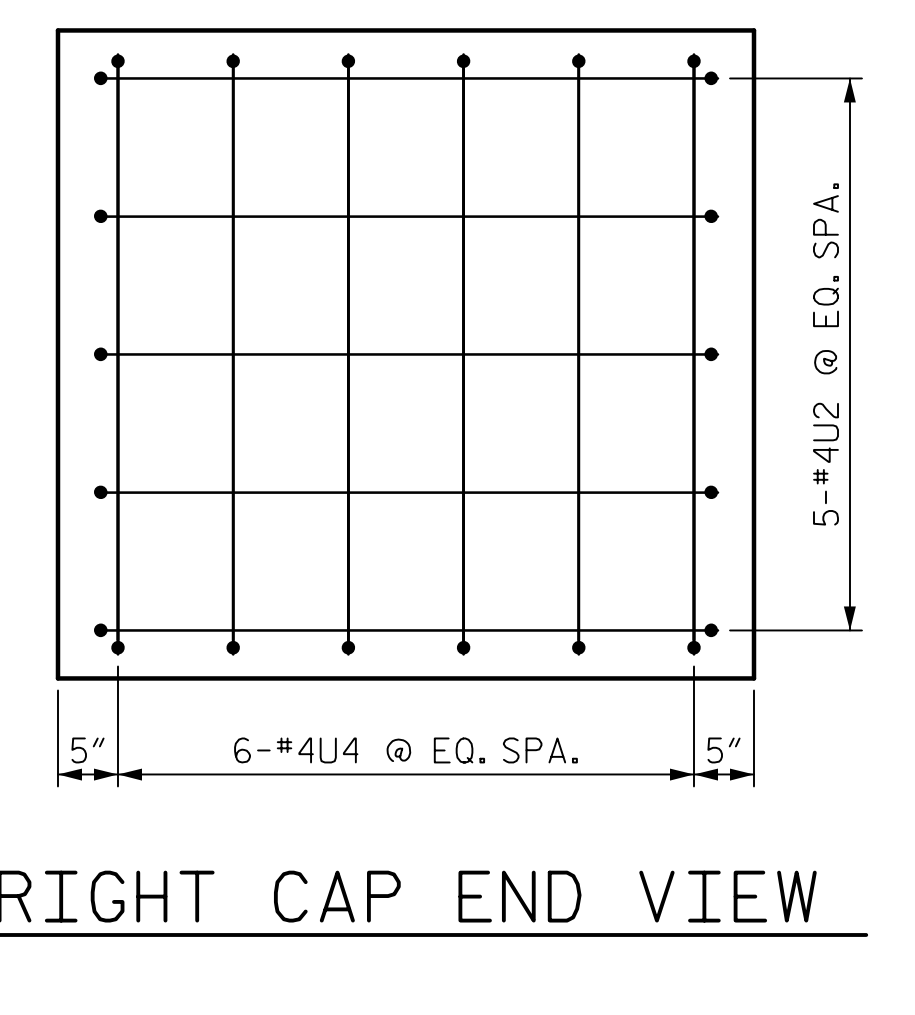

RIGHT CAP END VIEW

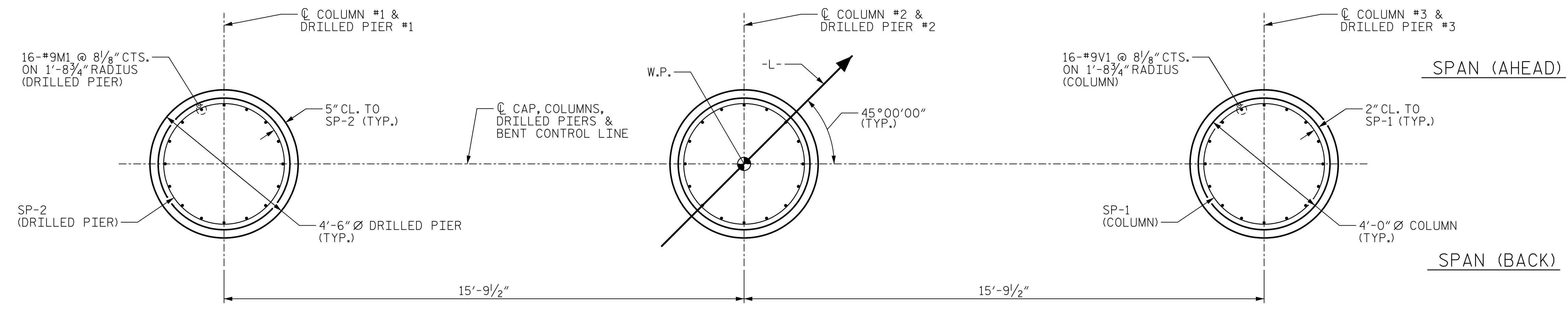

PLAN OF COLUMNS AND DRILLED PIERS  
DIMENSIONS AND REINFORCEMENT ARE TYPICAL FOR EACH COLUMN AND DRILLED PIER

DRAWN BY : M.K. TOM  
CHECKED BY : G.R. COLS  
DESIGNED BY : S. NATARAJAN  
DESIGN CHECKED BY : G.R. COLS

DATE : 11/2019  
DATE : 11/2019  
DATE : 11/2019  
DATE : 11/2019

DOCUMENT NOT CONSIDERED FINAL UNLESS ALL SIGNATURES COMPLETED

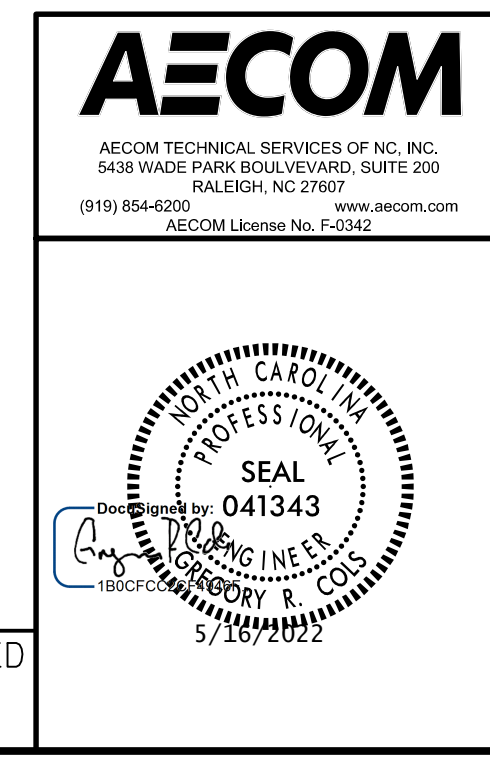

PROJECT NO. BR-0044  
ROCKINGHAM COUNTY  
STATION: 21+97.00 -L-

SHEET 2 OF 3

REVISIONS						SHEET NO.
NO.	BY:	DATE:	NO.	BY:	DATE:	S-32
1			3			TOTAL SHEETS
2			4			39

USER: gregcolby.dgn  
DGN: R:\Structures\04 Drawings\01\_0061\_BR0044\_LSMU\_LB102.dgn