

DATE: 3/29/2022
TIME: 2:25:37 PM

USER: Bin.Tam.C@hgtck.com
DIR: R:\Structures\04 Drawings\01_0044_BR0044_SML\GBR01.dgn

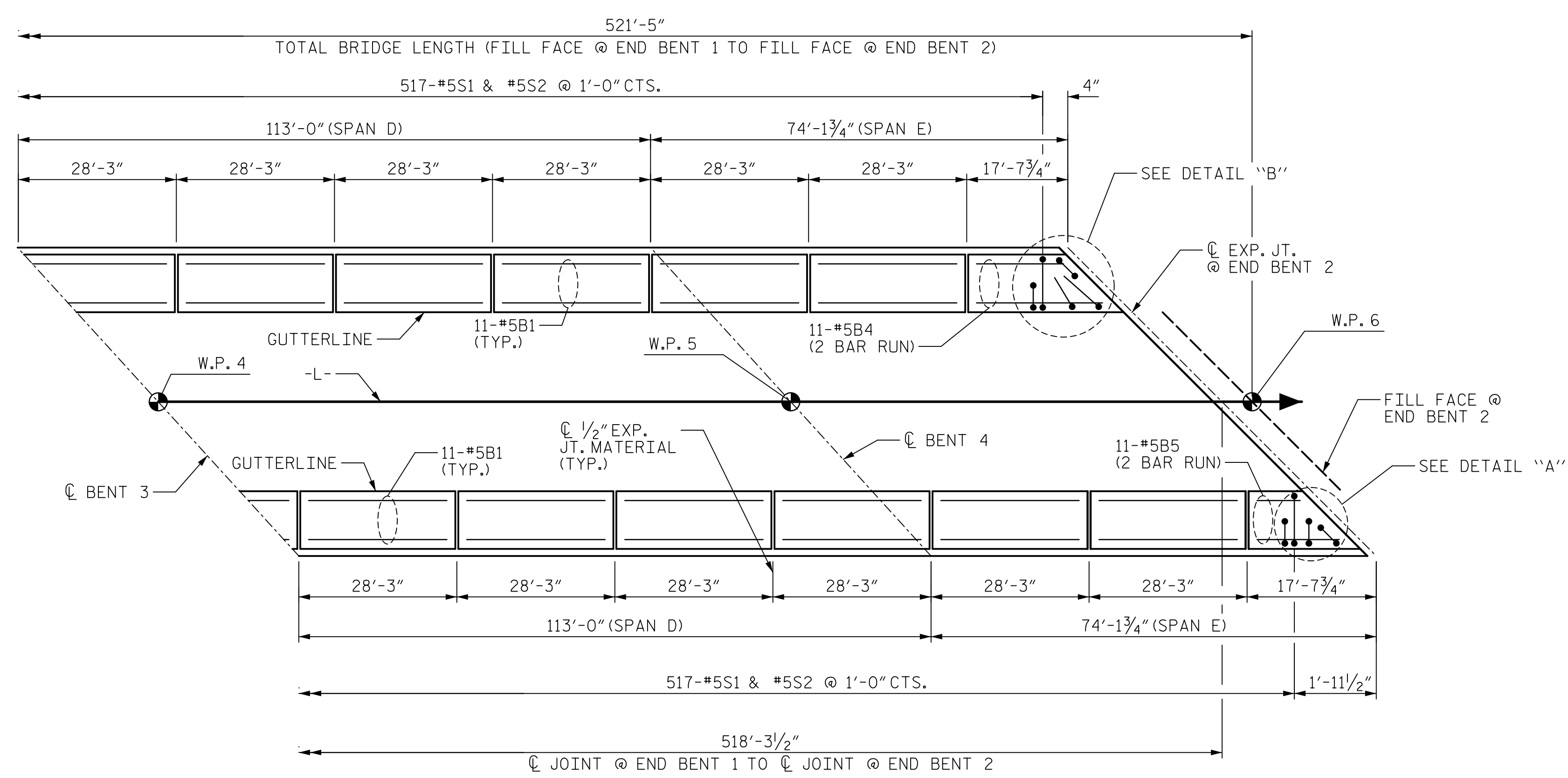
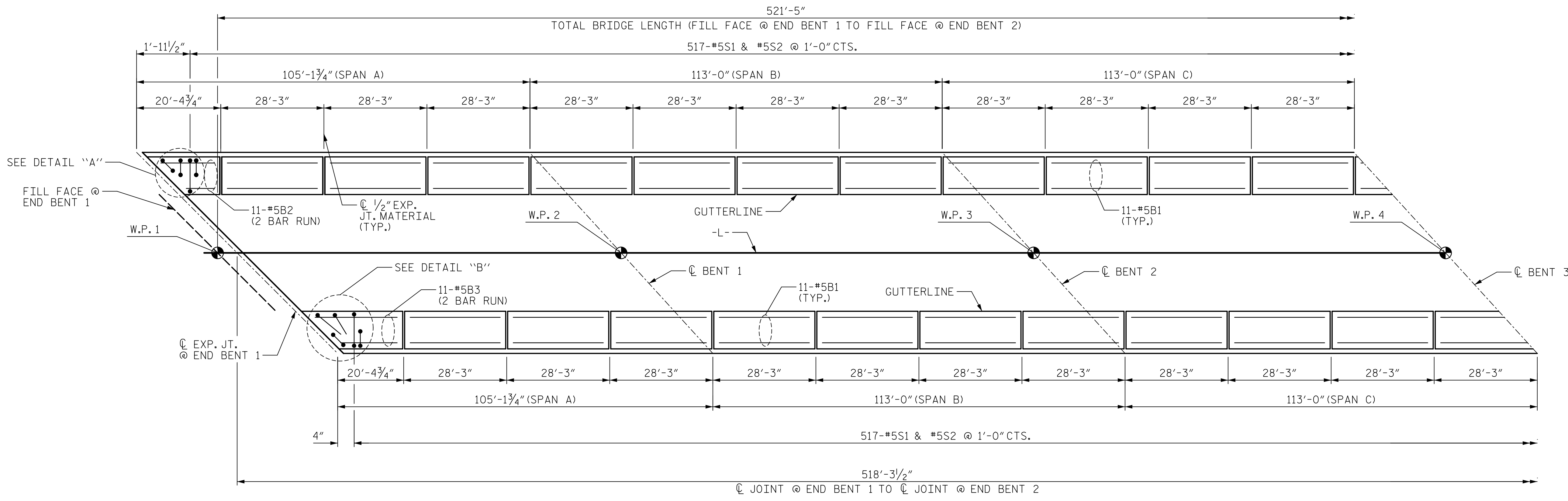

PROJECT NO. BR-0044
ROCKINGHAM COUNTY
STATION: 21+97.00 -L-

SHEET 1 OF 2

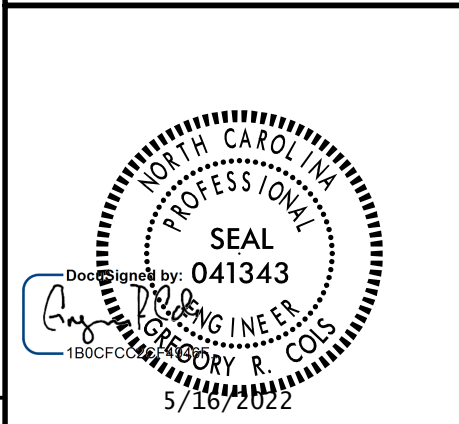

STATE OF NORTH CAROLINA
DEPARTMENT OF TRANSPORTATION
RALEIGH
SUPERSTRUCTURE
CONCRETE BARRIER RAIL

REVISIONS						SHEET NO.
NO.	BY:	DATE:	NO.	BY:	DATE:	S-21
1			3			TOTAL SHEETS
2			4			39

DRAWN BY : D.R. DRUM DATE : 03/2022
CHECKED BY : G.R. COLS DATE : 03/2022
DESIGNED BY : D.R. DRUM DATE : 03/2022
DESIGN CHECKED BY : G.R. COLS DATE : 03/2022

PLAN
FOR DETAILS "A" AND "B", SEE SHEET 2
DIMENSIONS SHOWN ALONG OUTSIDE OF DECK

DOCUMENT NOT CONSIDERED
FINAL UNLESS ALL
SIGNATURES COMPLETED