

PROJ. REFERENCE NO.	SHEET NO.
I-5987B	TMP-94

PLANS PREPARED FOR THE NCDOT BY:

M MOTT MACDONALD I & E, LLC
 1101 HAYNES STREET, SUITE 101
 RALEIGH, NC 27604
M MOTT MACDONALD NC LICENSE NO. F-0669

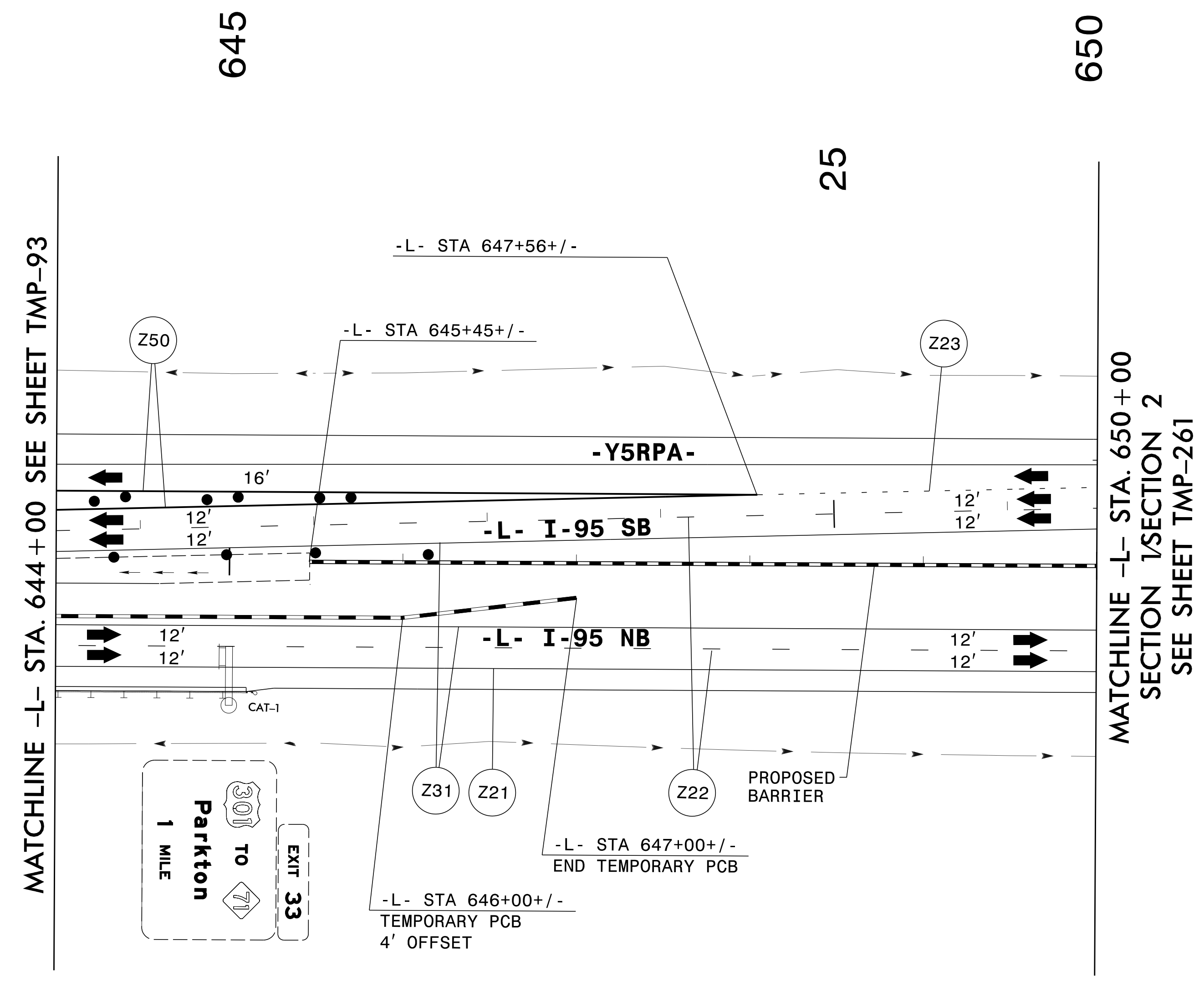

3/29/2022
 User: S:\1086221
 U:\S\1086221\I-5987B\TrafficControl\Top\200_443_I-5987B_TMP-94_Phase IV_Step 1.dgn

APPROVED: _____ DATE: _____			SECTION 1 TEMPORARY TRAFFIC CONTROL PHASE IV
DOCUMENT NOT CONSIDERED FINAL UNLESS ALL SIGNATURES COMPLETED			

PLANS PREPARED FOR THE NCDOT BY:

M MOTT MACDONALD I & E, LLC
 1101 HAYNES STREET, SUITE 101
 RALEIGH, NC 27604
M MOTT MACDONALD
 NC LICENSE NO. F-0669

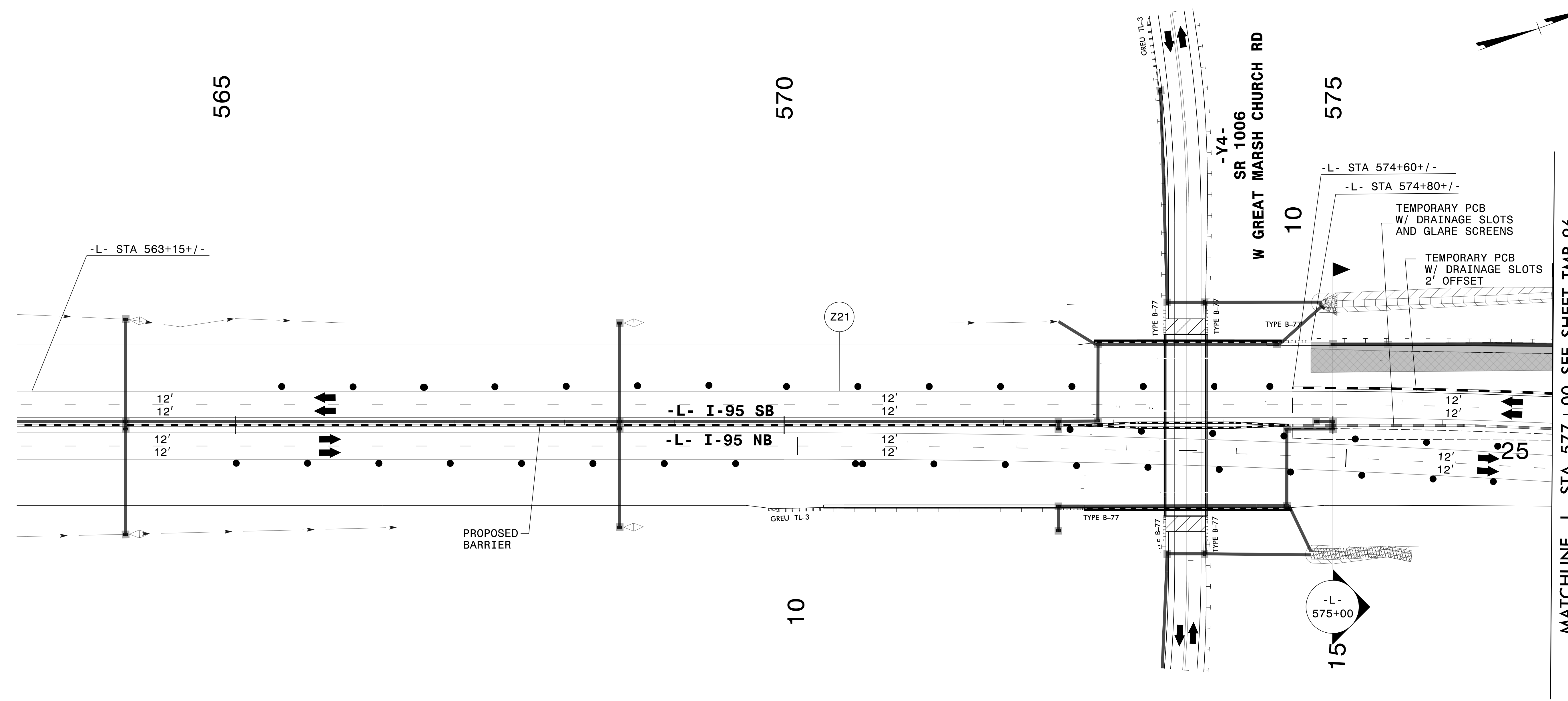
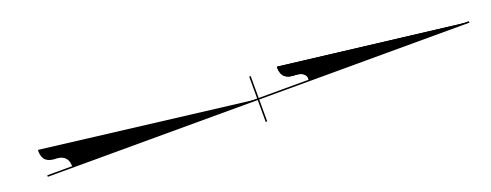

MATCHLINE -L- STA. 577 + 00 SEE SHEET TMP-96

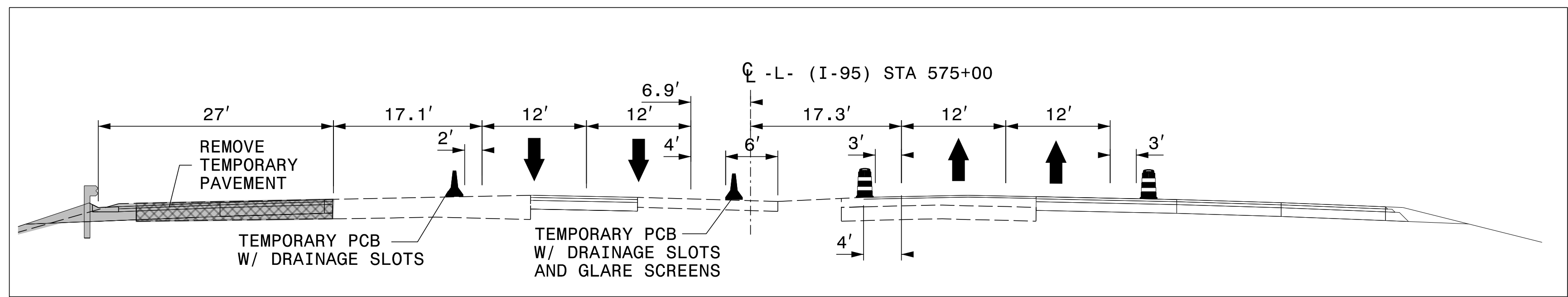

3/29/2022 G:\50100191\NV5_1-5987B\TrafficControl\Tc\200_445_1-5987B-TMP-95_Phase IV_Step 2_10.dgn User:ST086227

APPROVED: _____ DATE: _____			<p align="center">SECTION 1</p> <p align="center">TEMPORARY TRAFFIC CONTROL PHASE IV, STEP 2</p>
<p align="center">DOCUMENT NOT CONSIDERED FINAL UNLESS ALL SIGNATURES COMPLETED</p>			

PLANS PREPARED FOR THE NCDOT BY:

M MOTT MACDONALD I & E, LLC
1101 HAYNES STREET, SUITE 101
RALEIGH, NC 27604
NC LICENSE NO. F-0669

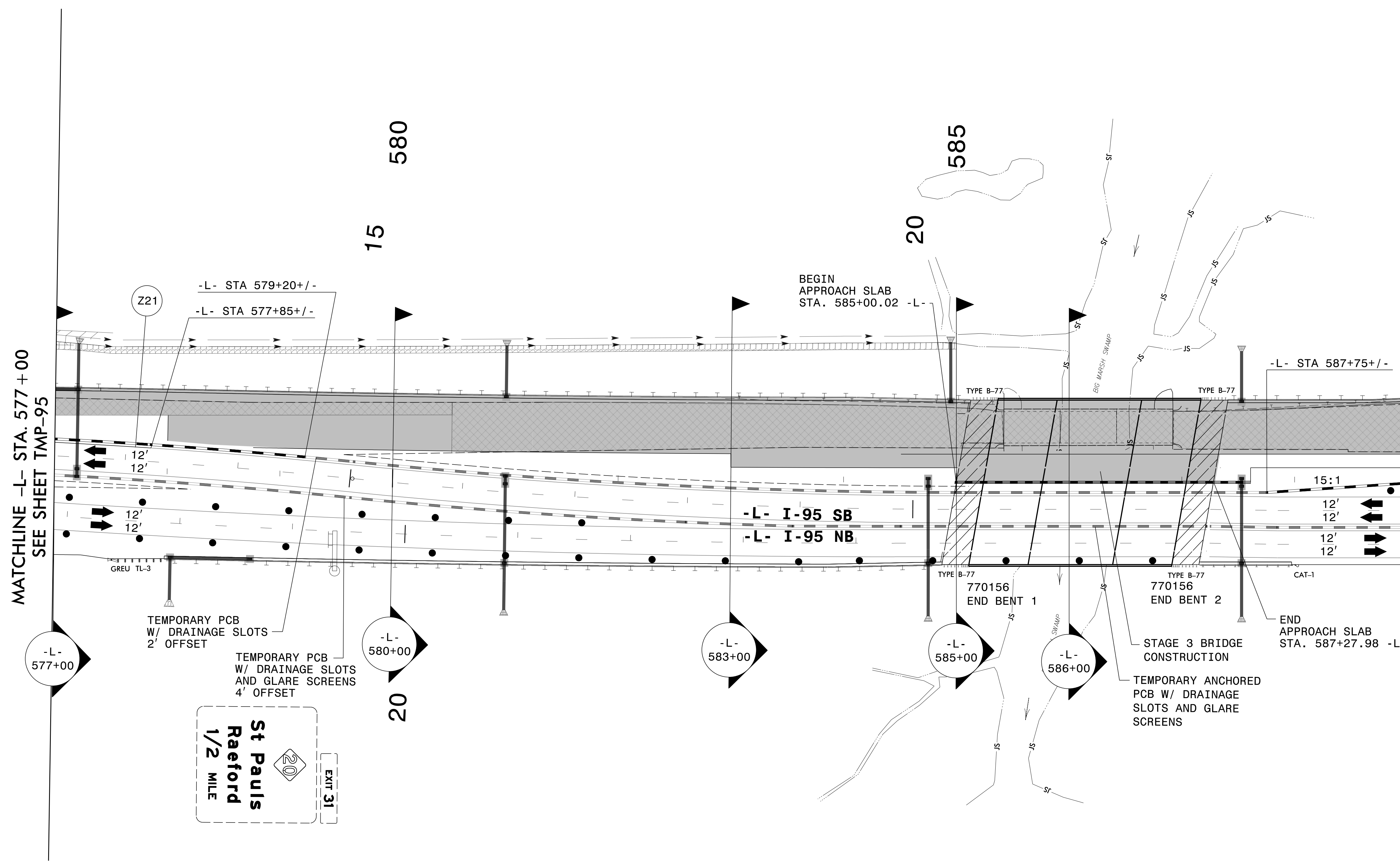
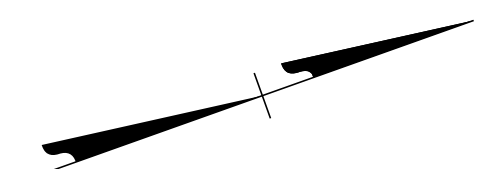

MATCHLINE -L- STA. 577 + 00
SEE SHEET TMP-95

MATCHLINE -L- STA. 589 + 00 SEE SHEET TMP-97

SEE SHEETS TMP-96A
AND TMP-96B
FOR SECTIONS

APPROVED: _____
DATE: _____

**DOCUMENT NOT CONSIDERED FINAL
UNLESS ALL SIGNATURES COMPLETED**

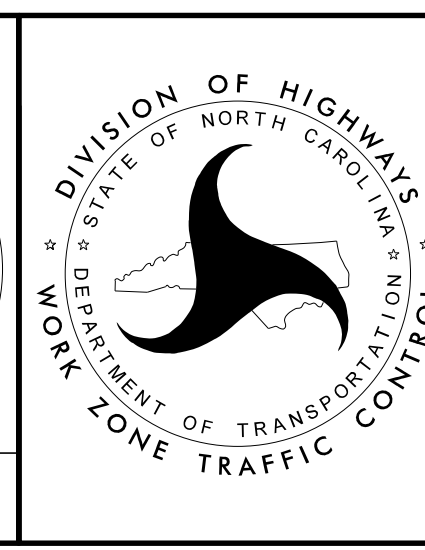

SECTION 1

**TEMPORARY TRAFFIC CONTROL
PHASE IV, STEP 2**

3/29/2022
G:\50100191\NV5_1-5987B\TrafficControl\Tc\200_447_1-5987B-TMP-96_Phase IV_Step 2_1.dgn
User:ST086227

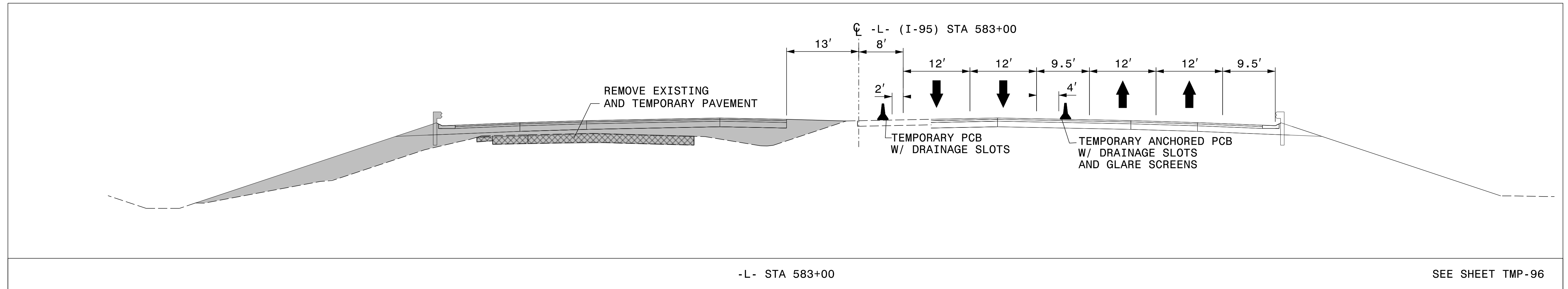
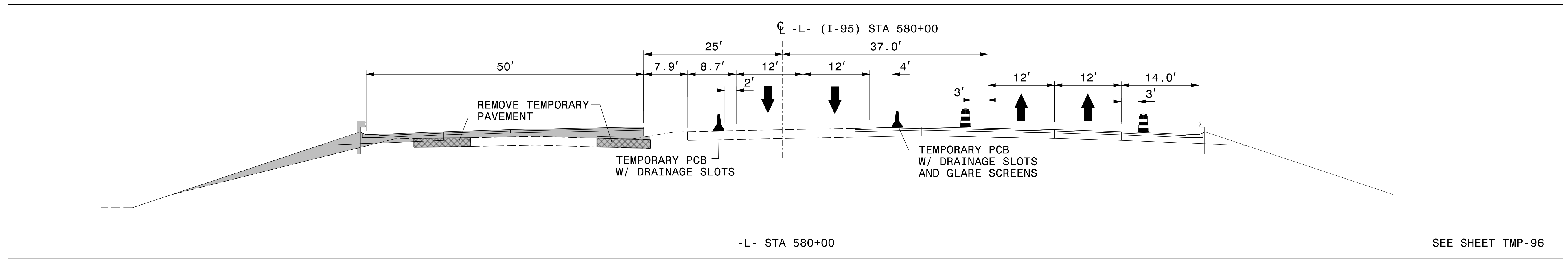
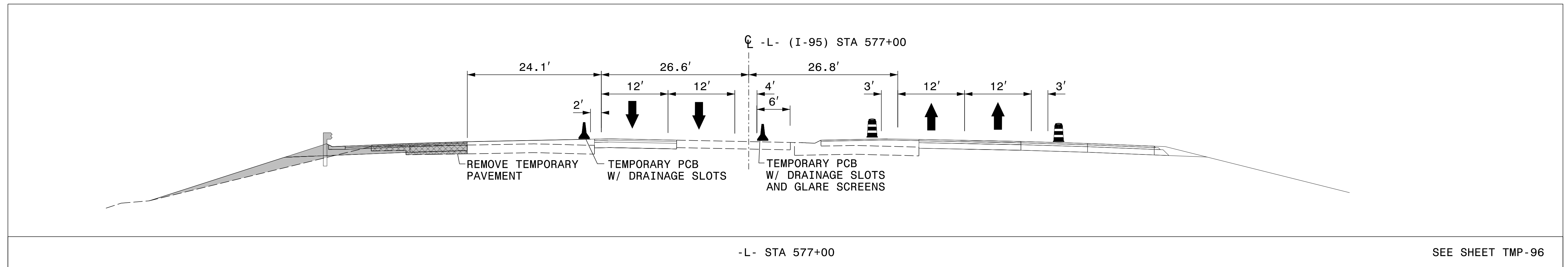

3/29/2022 G:\50100191_NV5_I-5987B\TrafficControl\Tc\200_449_I-5987B-TMP-96A_Phase IV Step 2.dgn User:ST086227

APPROVED: _____			SECTION 1 TEMPORARY TRAFFIC CONTROL PHASE IV, STEP 2
DATE: _____			

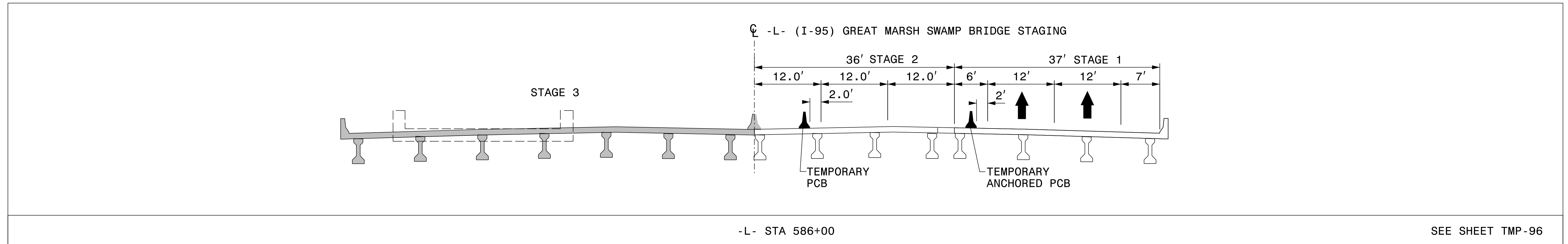
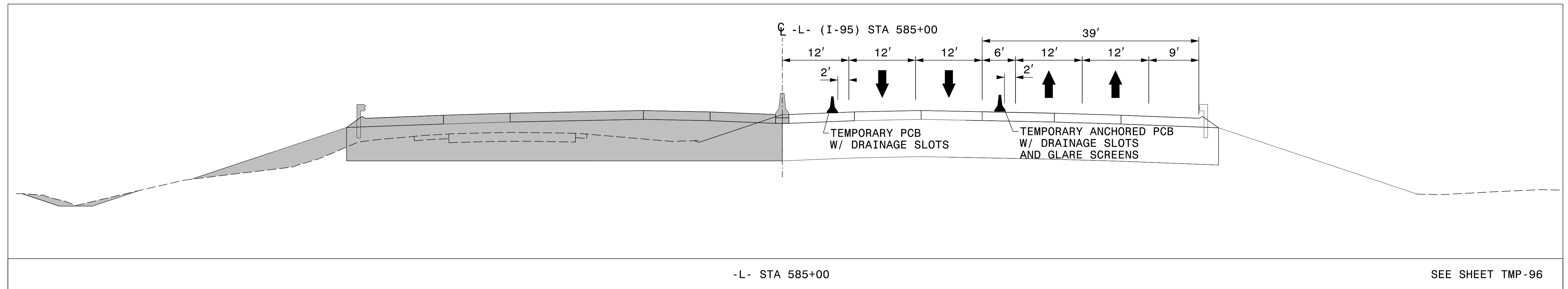

3/29/2022
 G:\50100191\NV5_L-5987B\TrafficControl\Tep\200_451_L-5987B_TMP-96B_Phase IV Step 2_.ilgn
 User:ST086227

APPROVED: _____			SECTION 1
DATE: _____			TEMPORARY TRAFFIC CONTROL PHASE IV, STEP 2
<p>DOCUMENT NOT CONSIDERED FINAL UNLESS ALL SIGNATURES COMPLETED</p>			

PLANS PREPARED FOR THE NCDOT BY:
M MOTT MACDONALD I & E, LLC
 1101 HAYNES STREET, SUITE 101
 RALEIGH, NC 27604
M MOTT MACDONALD
 NC LICENSE NO. F-0669

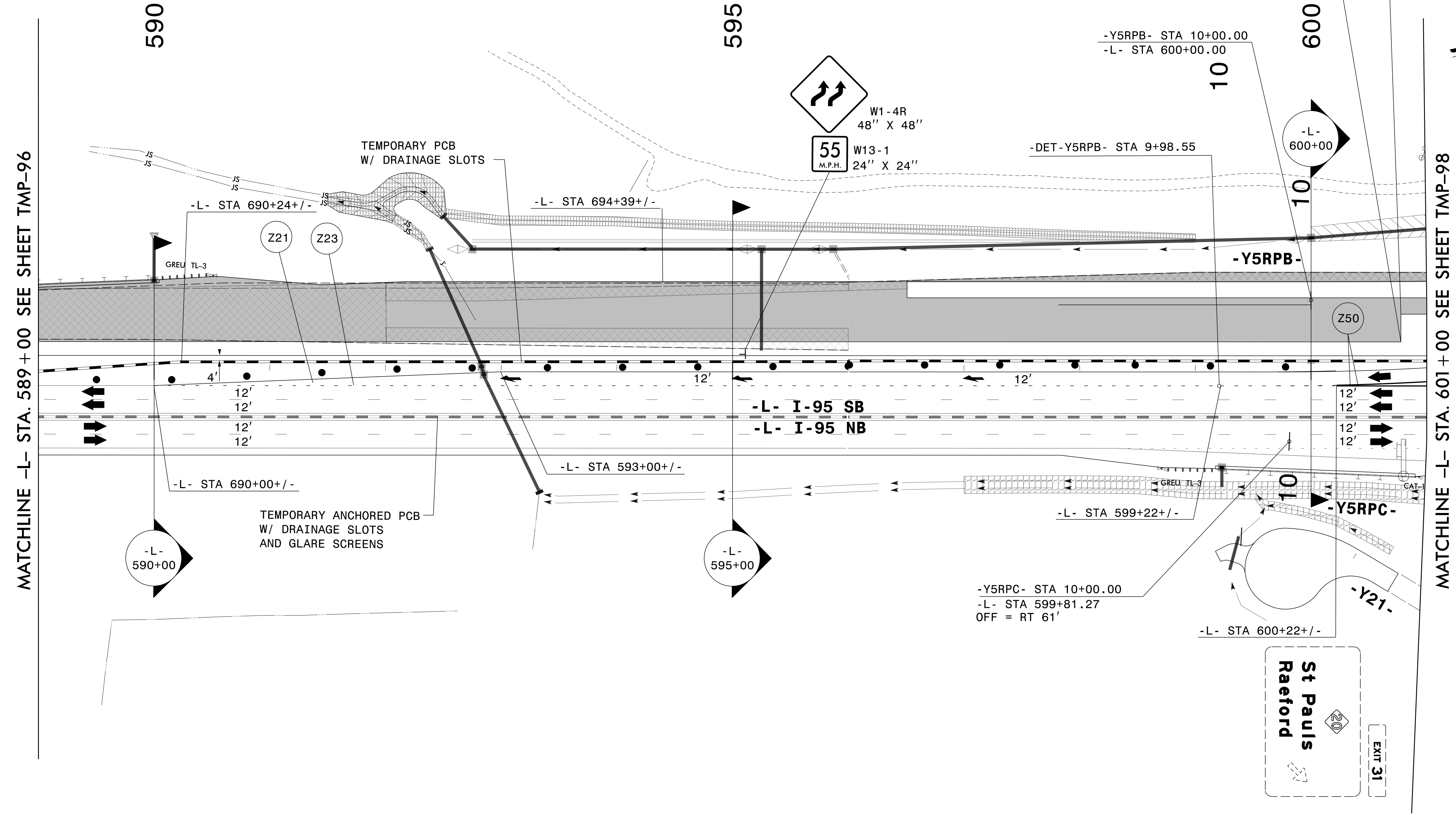

3/29/2022
 G:\50100191\NV5_1-5987B\TrafficControl\Tc\200_453_1-5987B-TMP-97_Phase IV_Step 2_1.dgn
 User:ST086227

SEE SHEET TMP-97A
FOR SECTIONS

APPROVED: _____ DATE: _____			SECTION 1 TEMPORARY TRAFFIC CONTROL PHASE IV, STEP 2
DOCUMENT NOT CONSIDERED FINAL UNLESS ALL SIGNATURES COMPLETED			

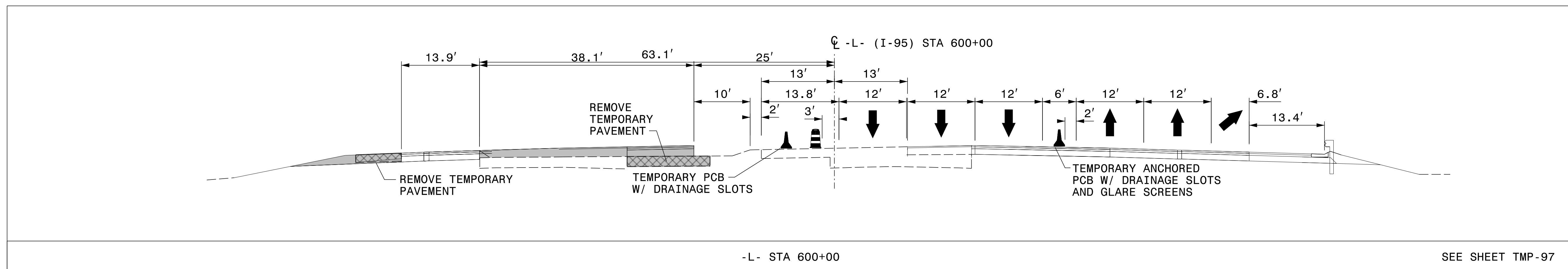
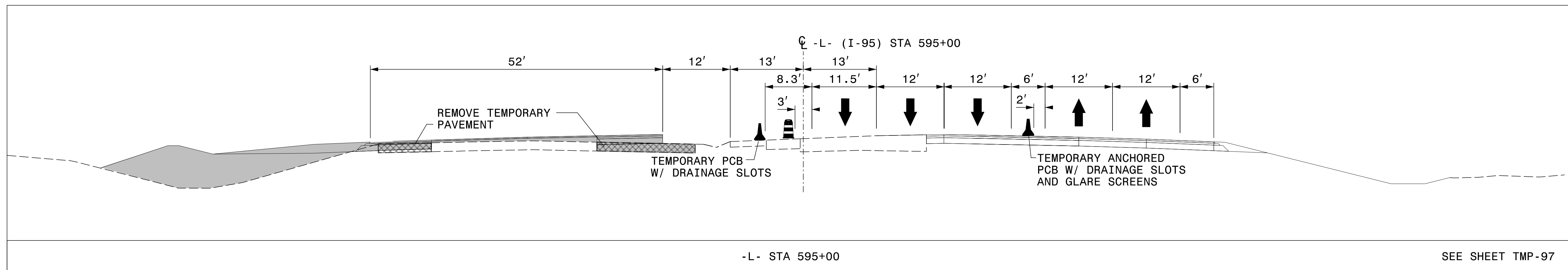
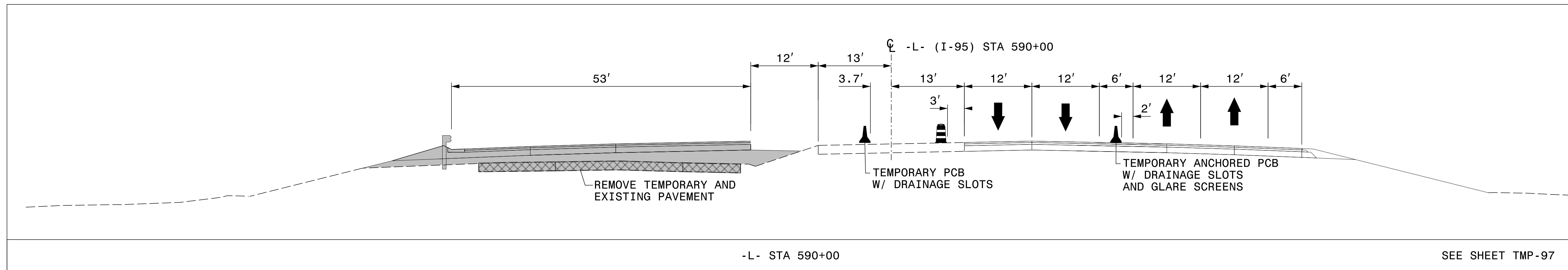

3/29/2022
 G:\50100191\NV5_1-5987B\TrafficControl\Tcpl\200_455_1-5987B-TMP-97A_Phase IV Step 2.dgn
 User:ST086227

APPROVED: _____
 DATE: _____

**DOCUMENT NOT CONSIDERED FINAL
 UNLESS ALL SIGNATURES COMPLETED**

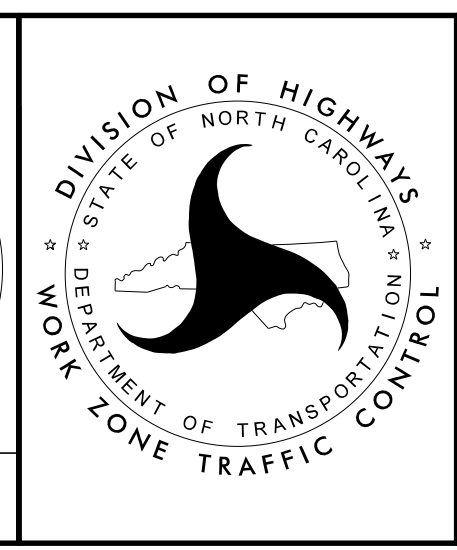

SECTION 1

**TEMPORARY TRAFFIC CONTROL
 PHASE IV, STEP 2**

PLANS PREPARED FOR THE NCDOT BY:
M MOTT MACDONALD I & E, LLC
 1101 HAYNES STREET, SUITE 101
 RALEIGH, NC 27604
M MOTT MACDONALD
 NC LICENSE NO. F-0669

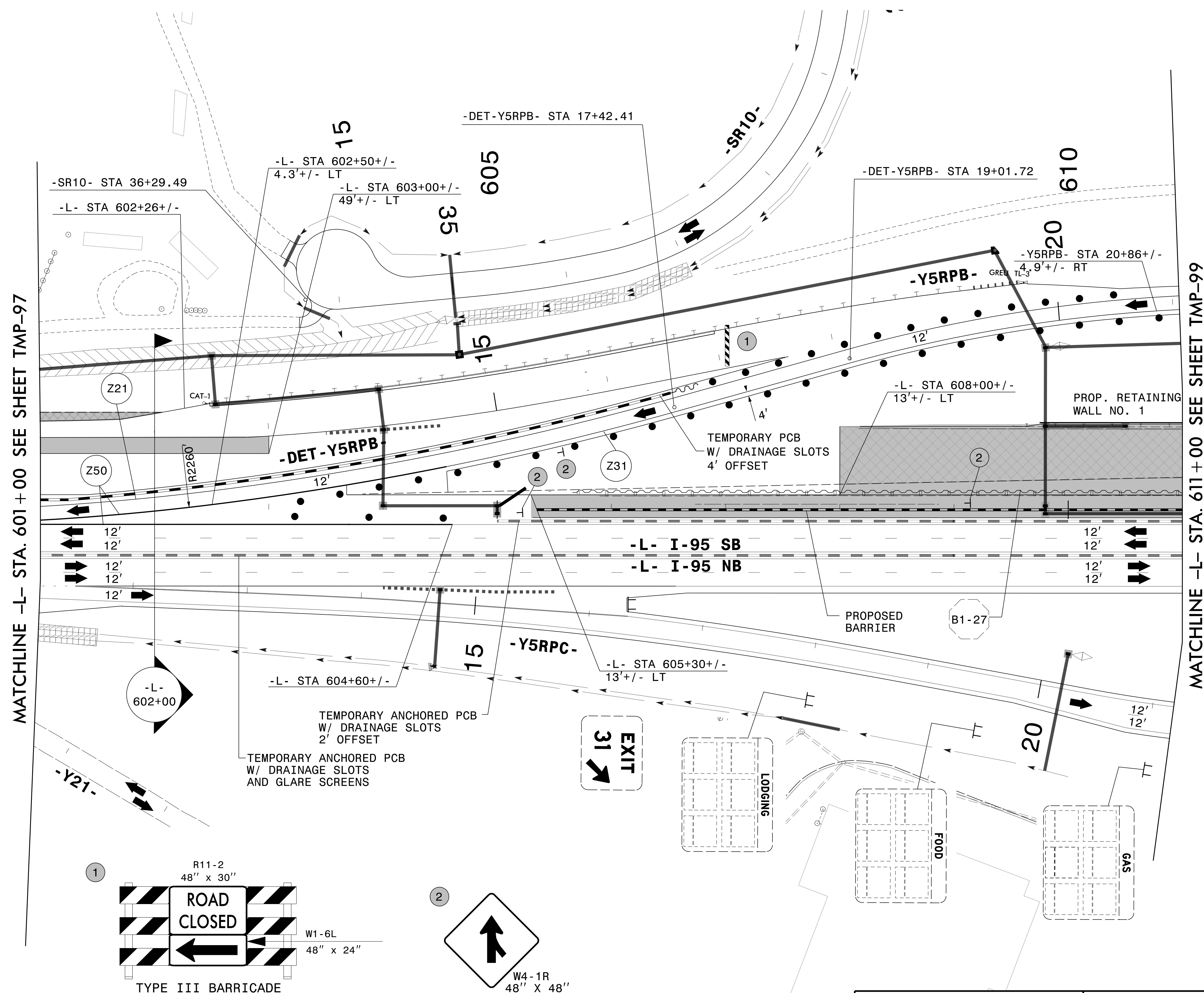
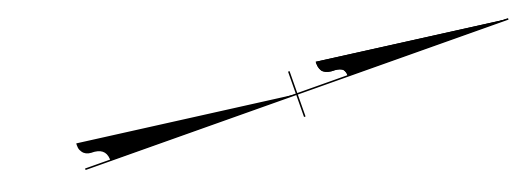

MATCHLINE -L- STA. 601+00 SEE SHEET TMP-97

MATCHLINE -L- STA. 611+00 SEE SHEET TMP-99

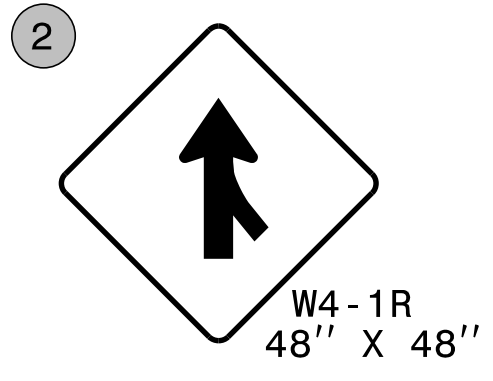
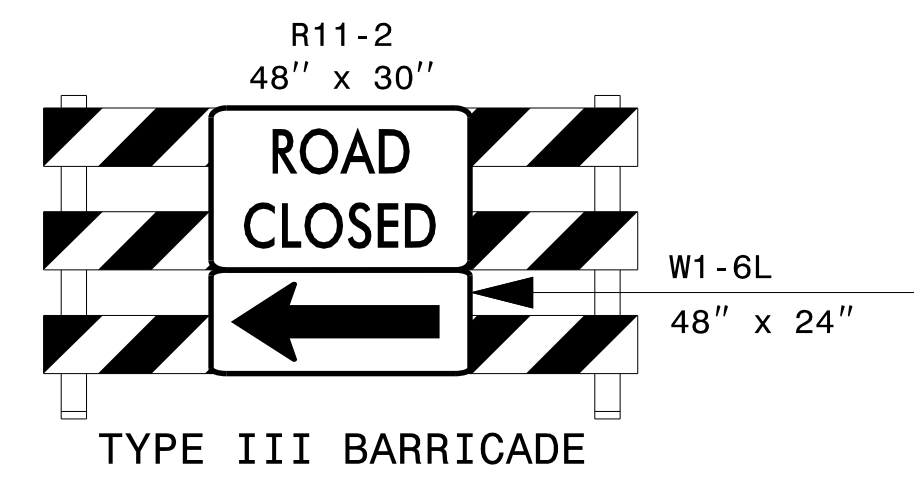

SEE SHEET TMP-98A FOR SECTION

APPROVED: _____
 DATE: _____

DOCUMENT NOT CONSIDERED FINAL UNLESS ALL SIGNATURES COMPLETED

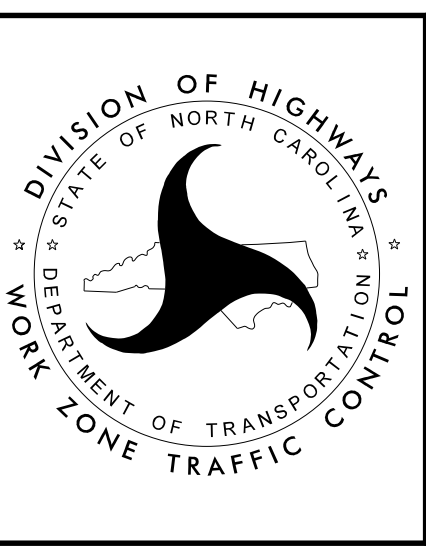

SECTION 1

**TEMPORARY TRAFFIC CONTROL
 PHASE IV, STEP 2**

3/29/2022 G:\50100191\NV5_I-5987B\TrafficControl\Tc\200_457_I-5987B-TMP-98_Phase IV_Step 2_13.dgn User:ST086227

PROJ. REFERENCE NO.	SHEET NO.
I-5987B	TMP-98A

PLANS PREPARED FOR THE NCDOT BY:

M MOTT MACDONALD I & E, LLC
 1101 HAYNES STREET, SUITE 101
 RALEIGH, NC 27604
M MOTT MACDONALD
 NC LICENSE NO. F-0669

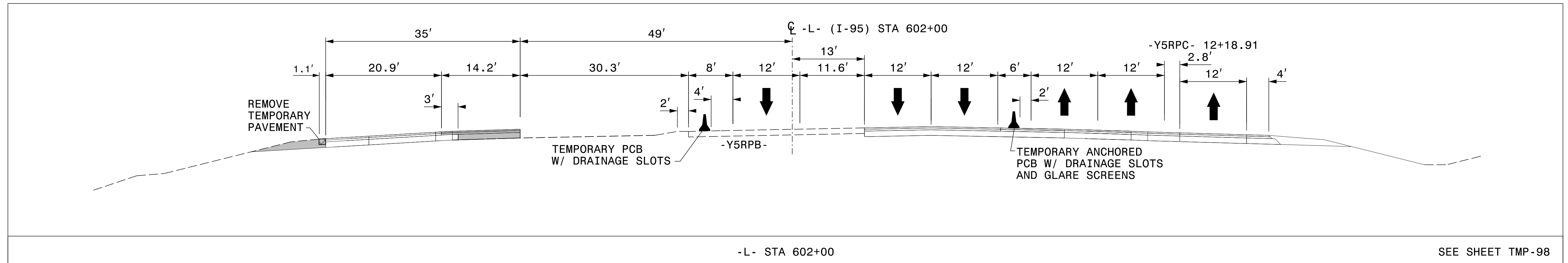

-L- STA 602+00

SEE SHEET TMP-98

3/29/2022
 G:\50100191_NV5_I-5987B\TrafficControl\Top\200_459_I-5987B-TMP-98A_Phase IV Step 2_13.dgn
 User:ST086227

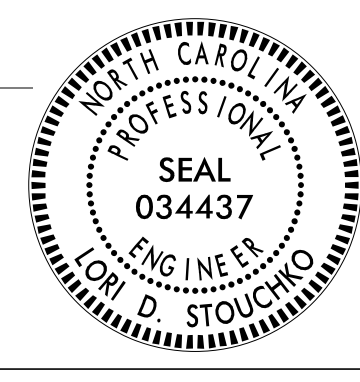
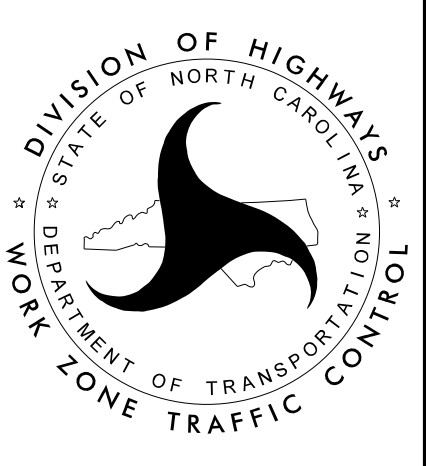
APPROVED: _____ DATE: _____ 		<p style="text-align: center;">SECTION 1</p> <p style="text-align: center;">TEMPORARY TRAFFIC CONTROL PHASE IV, STEP 2</p>
<p style="text-align: center;">DOCUMENT NOT CONSIDERED FINAL UNLESS ALL SIGNATURES COMPLETED</p>		

PLANS PREPARED FOR THE NCDOT BY:
M MOTT MACDONALD I & E, LLC
 1101 HAYNES STREET, SUITE 101
 RALEIGH, NC 27604
 NC LICENSE NO. F-0669

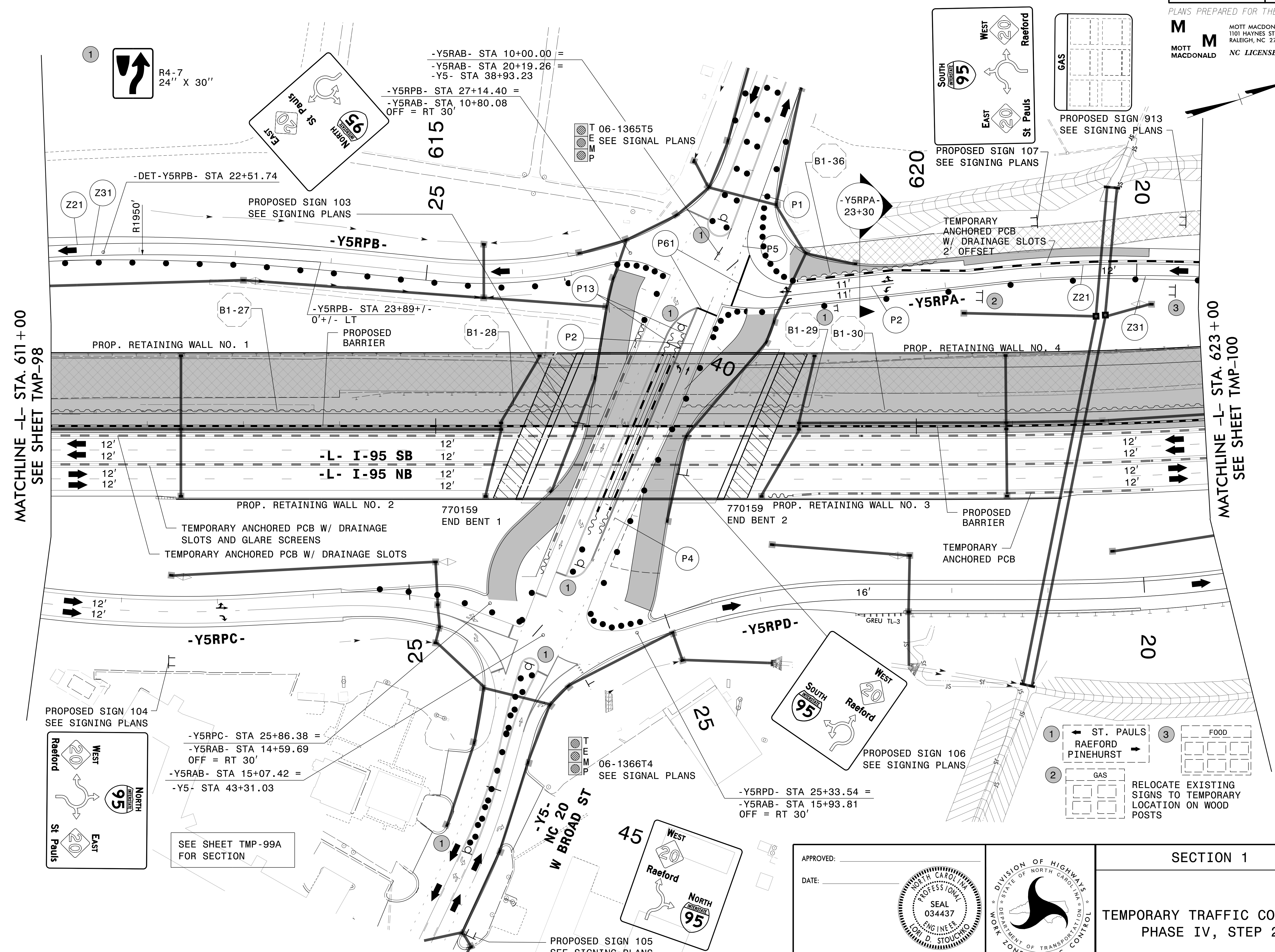

MATCHLINE -L- STA. 611+00
 SEE SHEET TMP-98

MATCHLINE -L- STA. 623+00
 SEE SHEET TMP-100

PROPOSED SIGN 104
 SEE SIGNING PLANS

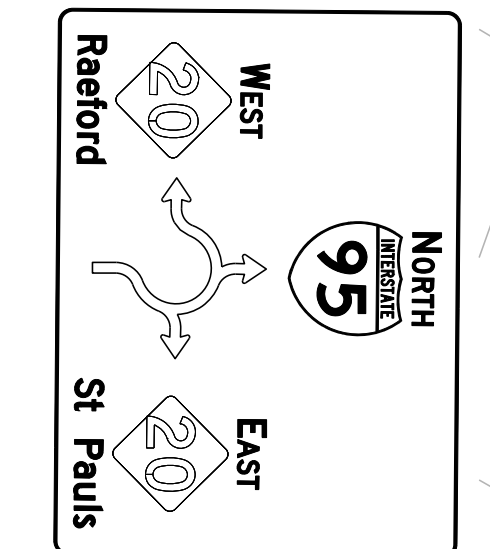

SEE SHEET TMP-99A
 FOR SECTION

PROPOSED SIGN 106
 SEE SIGNING PLANS

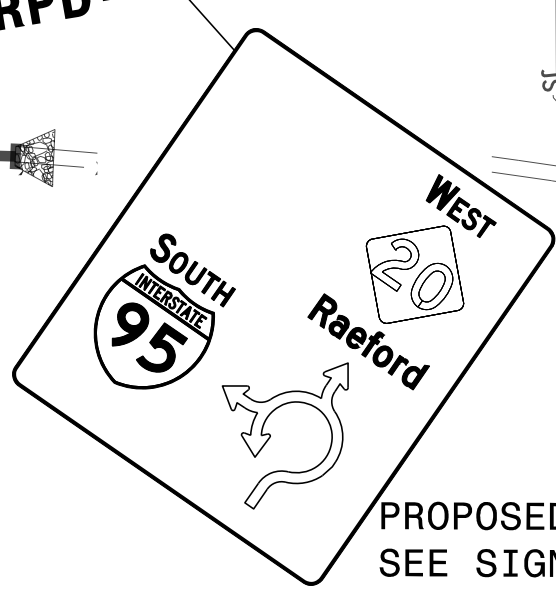

-Y5RPD- STA 25+33.54 =
 -Y5RAB- STA 15+93.81
 OFF = RT 30'

PROPOSED SIGN 105
 SEE SIGNING PLANS

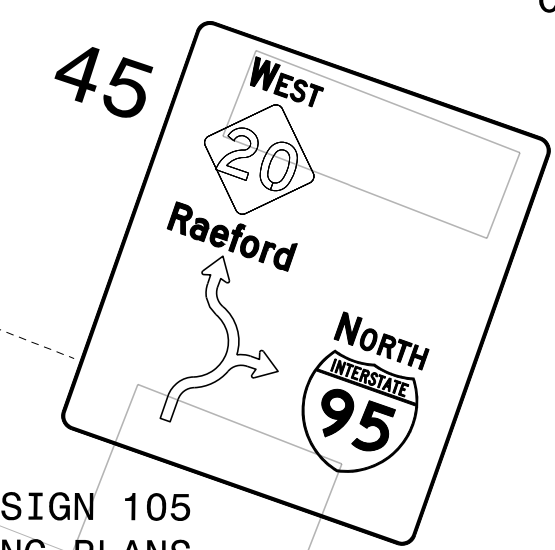

APPROVED: _____
 DATE: _____

**DOCUMENT NOT CONSIDERED FINAL
 UNLESS ALL SIGNATURES COMPLETED**

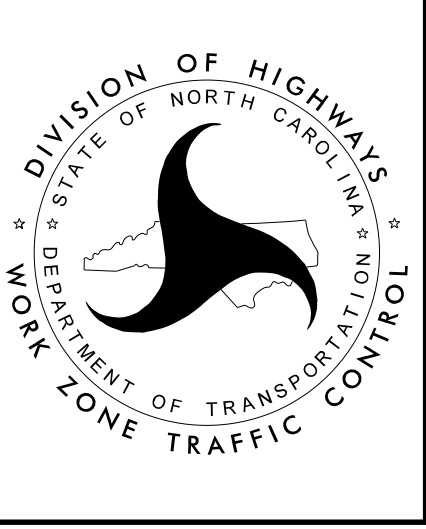

SECTION 1
**TEMPORARY TRAFFIC CONTROL
 PHASE IV, STEP 2**

3/29/2022
 G:\50100191\NV5_L-5987B\TrafficControl\Tc\200_461-L-5987B-TMP-99_Phase IV Step 2.dwg
 User:ST086227

PROJ. REFERENCE NO.	SHEET NO.
I-5987B	TMP-99A

PLANS PREPARED FOR THE NCDOT BY:

M MOTT MACDONALD I & E, LLC
 1101 HAYNES STREET, SUITE 101
 RALEIGH, NC 27604
M MOTT MACDONALD NC LICENSE NO. F-0669

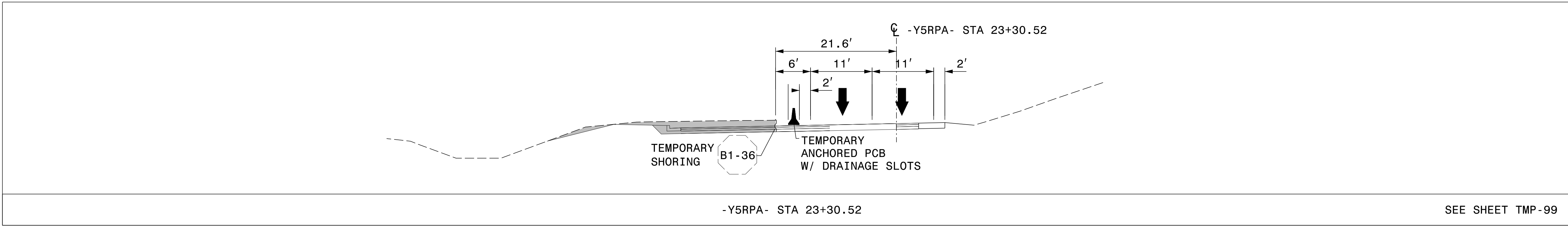

3/29/2022
 G:\50100191\NV5_I-5987B\TrafficControl\Tcpl\200_463_I-5987B-TMP-99A_Phase IV Step 2_14.dgn
 User:ST086227

APPROVED: _____			SECTION 1
DATE: _____			TEMPORARY TRAFFIC CONTROL PHASE IV, STEP 2
DOCUMENT NOT CONSIDERED FINAL UNLESS ALL SIGNATURES COMPLETED			

PLANS PREPARED FOR THE NCDOT BY:
M MOTT MACDONALD I & E, LLC
 1101 HAYNES STREET, SUITE 101
 RALEIGH, NC 27604
M MOTT MACDONALD NC LICENSE NO. F-0669

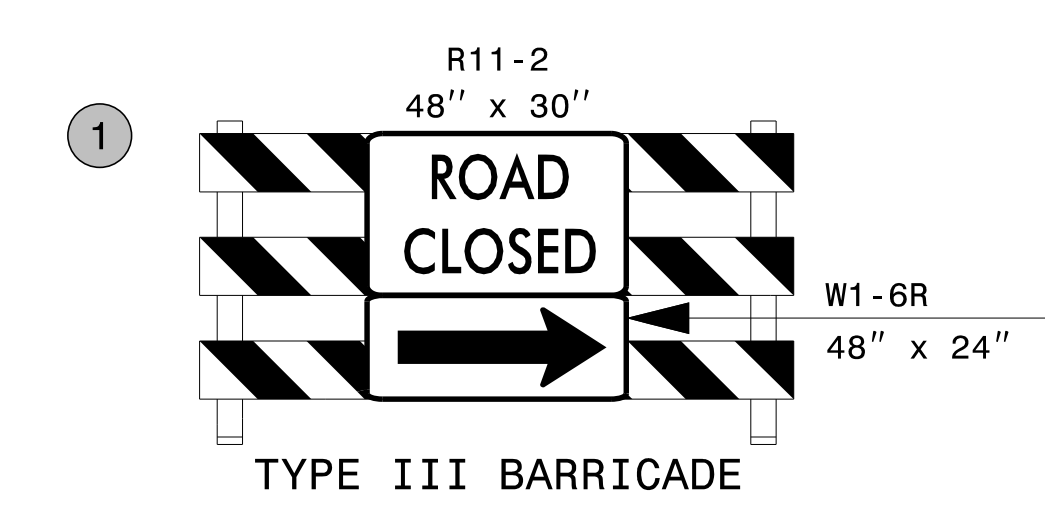
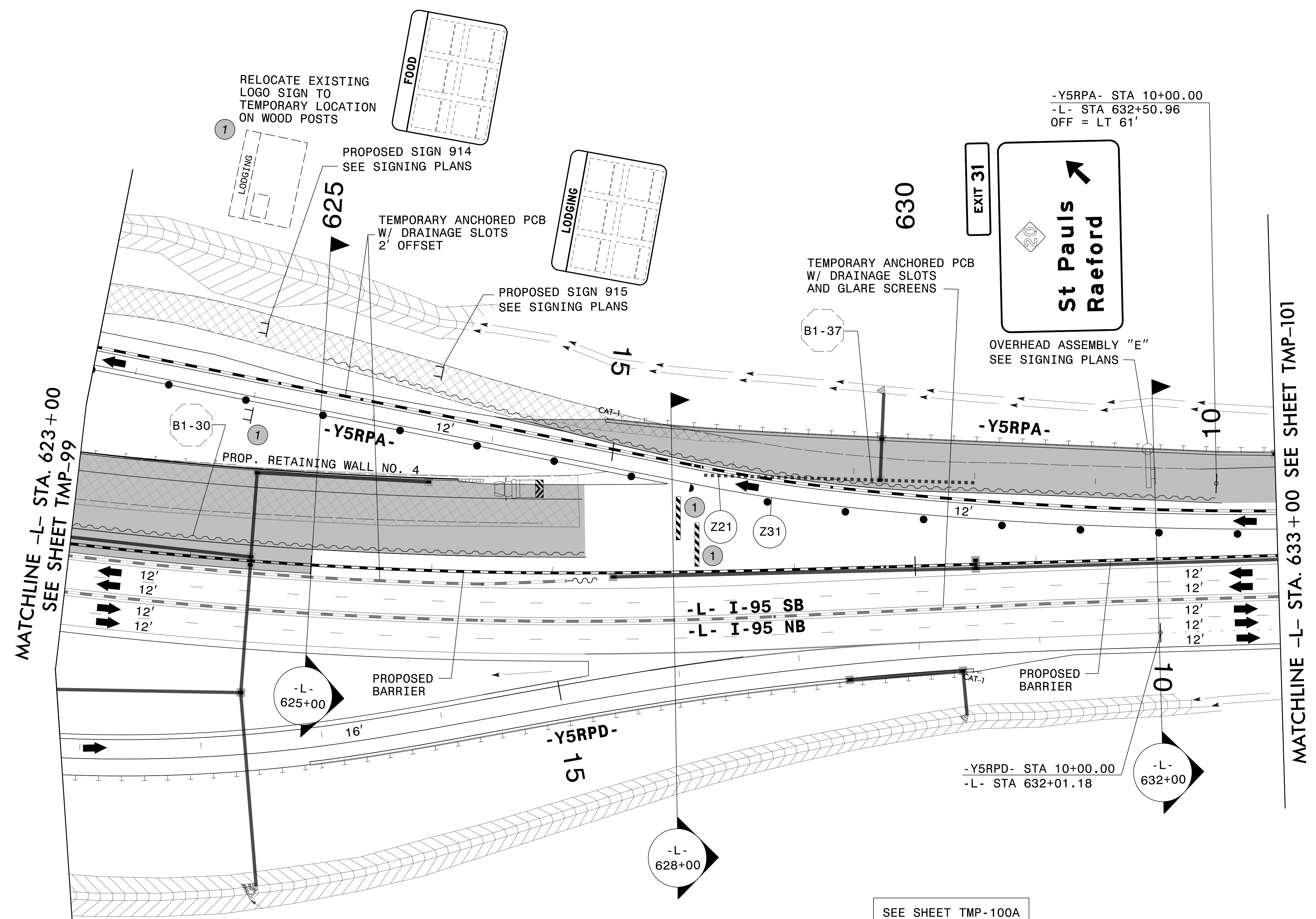
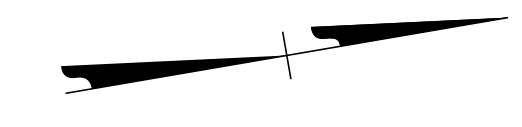

APPROVED: _____

DATE: _____

SEAL
034437
ENGINEER
LORI D. STOUCHE

DOCUMENT NOT CONSIDERED FINAL
UNLESS ALL SIGNATURES COMPLETED

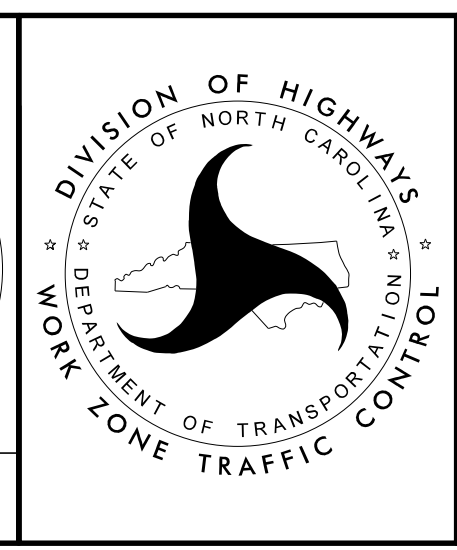

SECTION 1

TEMPORARY TRAFFIC CONTROL
PHASE IV, STEP 2

3/29/2022 G:\50100191\NV5_L-5987B\TrafficControl\Tc\200_465_L-5987B-TMP-100_Phase IV_Step 2_15.dgn User:ST086227

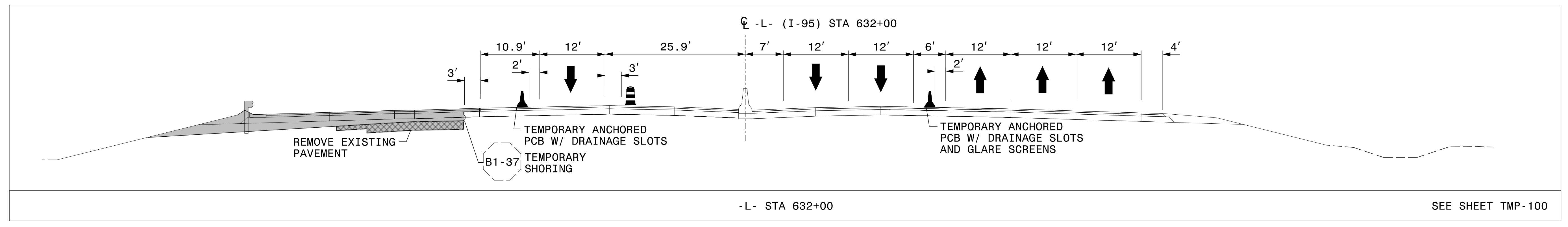
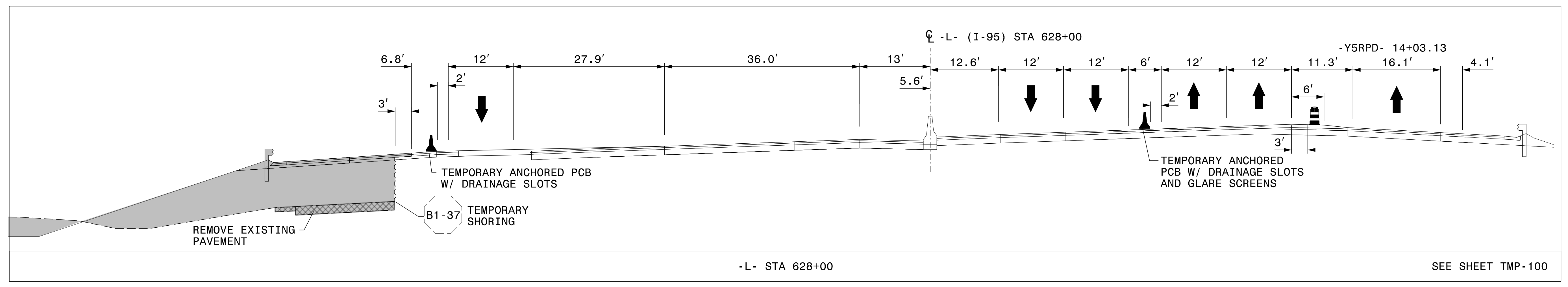
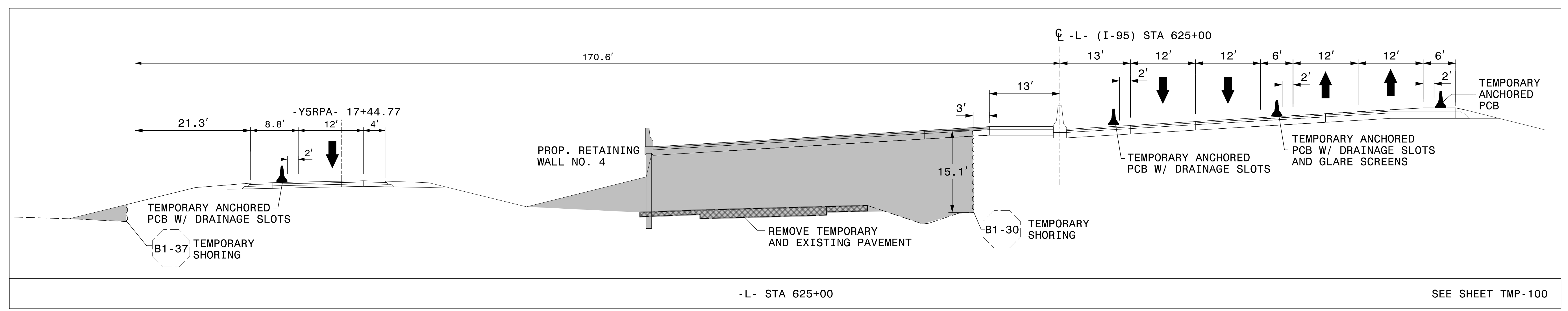

3/29/2022 G:\50100191\NV5_I-5987B\TrafficControl\Tc\200_467_I-5987B-TMP-100A.Phase IV Step 2_15.dgn User:ST086227

APPROVED: _____

DATE: _____

SEAL
034437
ENGINEER
LORI D. STOUCHE

**DOCUMENT NOT CONSIDERED FINAL
UNLESS ALL SIGNATURES COMPLETED**

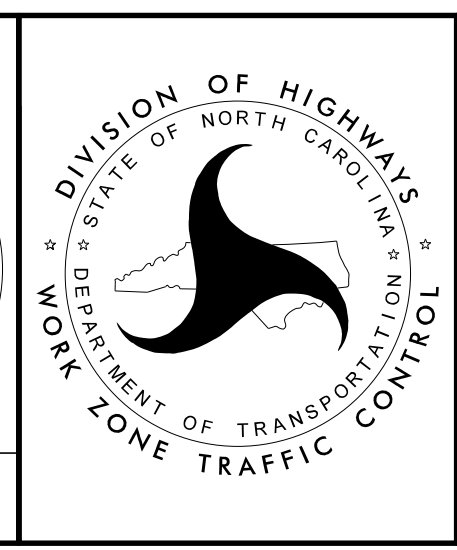

SECTION 1

**TEMPORARY TRAFFIC CONTROL
PHASE IV, STEP 2**

PLANS PREPARED FOR THE NCDOT BY:

M MOTT MACDONALD I & E, LLC
 1101 HAYNES STREET, SUITE 101
 RALEIGH, NC 27604
M MOTT MACDONALD NC LICENSE NO. F-0669

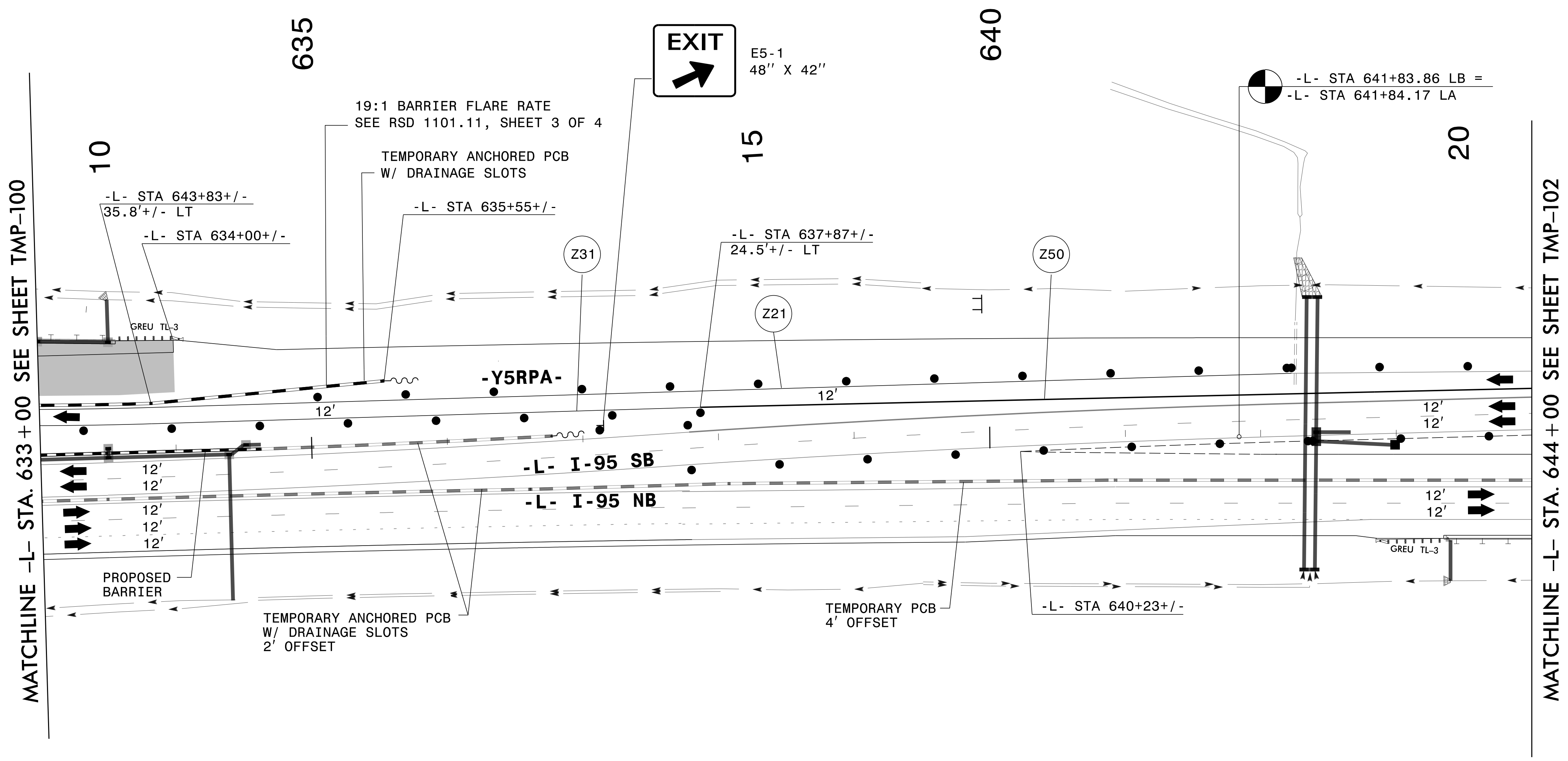
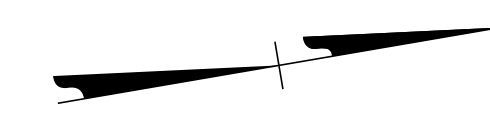

MATCHLINE -L- STA. 633+00 SEE SHEET TMP-100

MATCHLINE -L- STA. 644+00 SEE SHEET TMP-102

3/29/2022
 G:\50100191\NV5_1-5987B\TrafficControl\Top\200_469_1-5987B-TMP-101LPhase IV Step 2_16.dgn
 User:ST086227

APPROVED: _____
 DATE: _____

**DOCUMENT NOT CONSIDERED FINAL
 UNLESS ALL SIGNATURES COMPLETED**

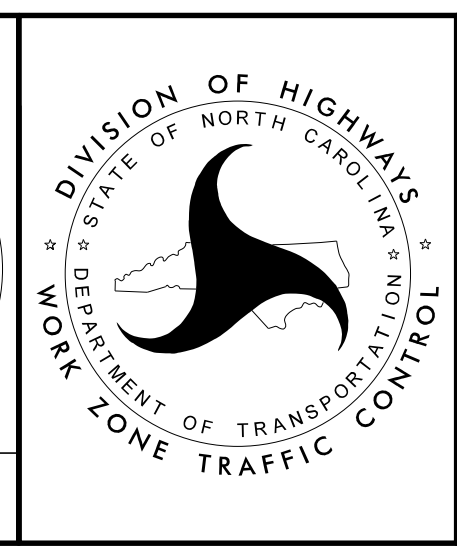
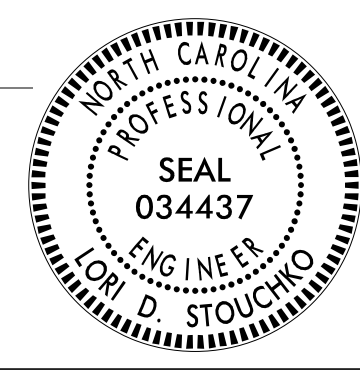

SECTION 1

**TEMPORARY TRAFFIC CONTROL
 PHASE IV, STEP 2**

PROJ. REFERENCE NO.	SHEET NO.
I-5987B	TMP-102

PLANS PREPARED FOR THE NCDOT BY:

M MOTT MACDONALD I & E, LLC
 1101 HAYNES STREET, SUITE 101
 RALEIGH, NC 27604
M MOTT MACDONALD NC LICENSE NO. F-0669

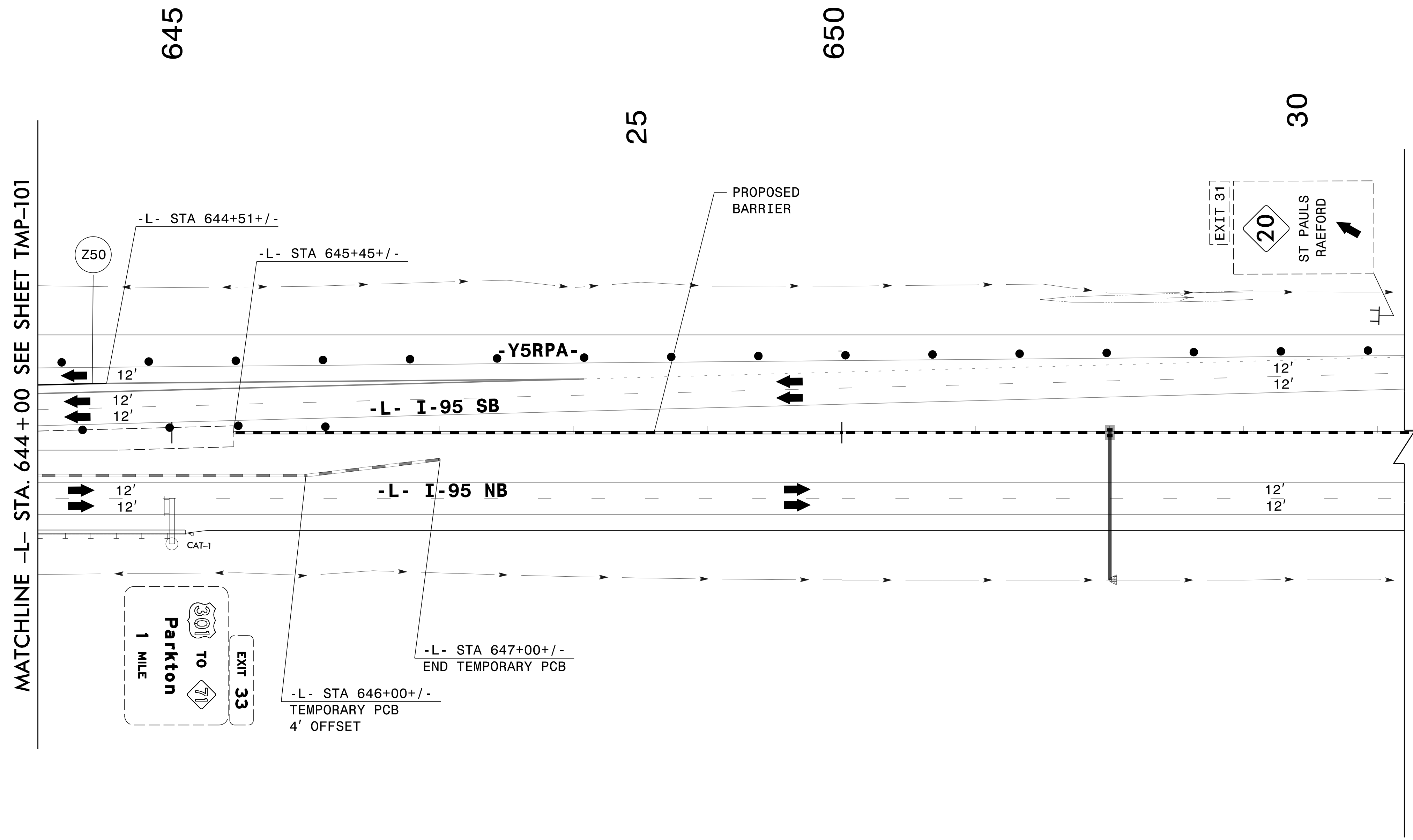
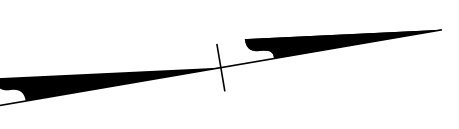

MATCHLINE -L- STA. 644 + 00 SEE SHEET TMP-101

3/29/2022 G:\50100191\NV5_1-5987B\TrafficControl\Tcpl\200_471\I-5987B_TMP-102_Phase IV_Step 2.dgn User:ST086227

APPROVED: _____
 DATE: _____

**DOCUMENT NOT CONSIDERED FINAL
 UNLESS ALL SIGNATURES COMPLETED**



SECTION 1

**TEMPORARY TRAFFIC CONTROL
 PHASE IV, STEP 2**

PLANS PREPARED FOR THE NCDOT BY:

M MOTT MACDONALD I & E, LLC
 1101 HAYNES STREET, SUITE 101
 RALEIGH, NC 27604
M MOTT MACDONALD NC LICENSE NO. F-0669

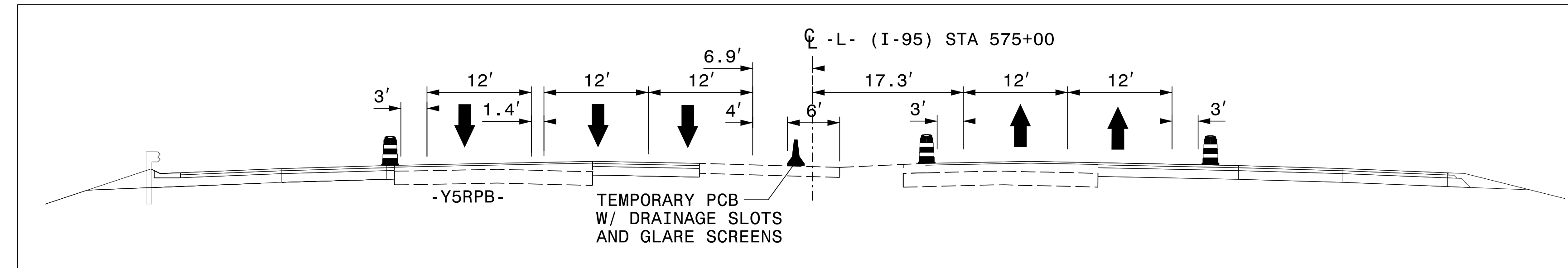
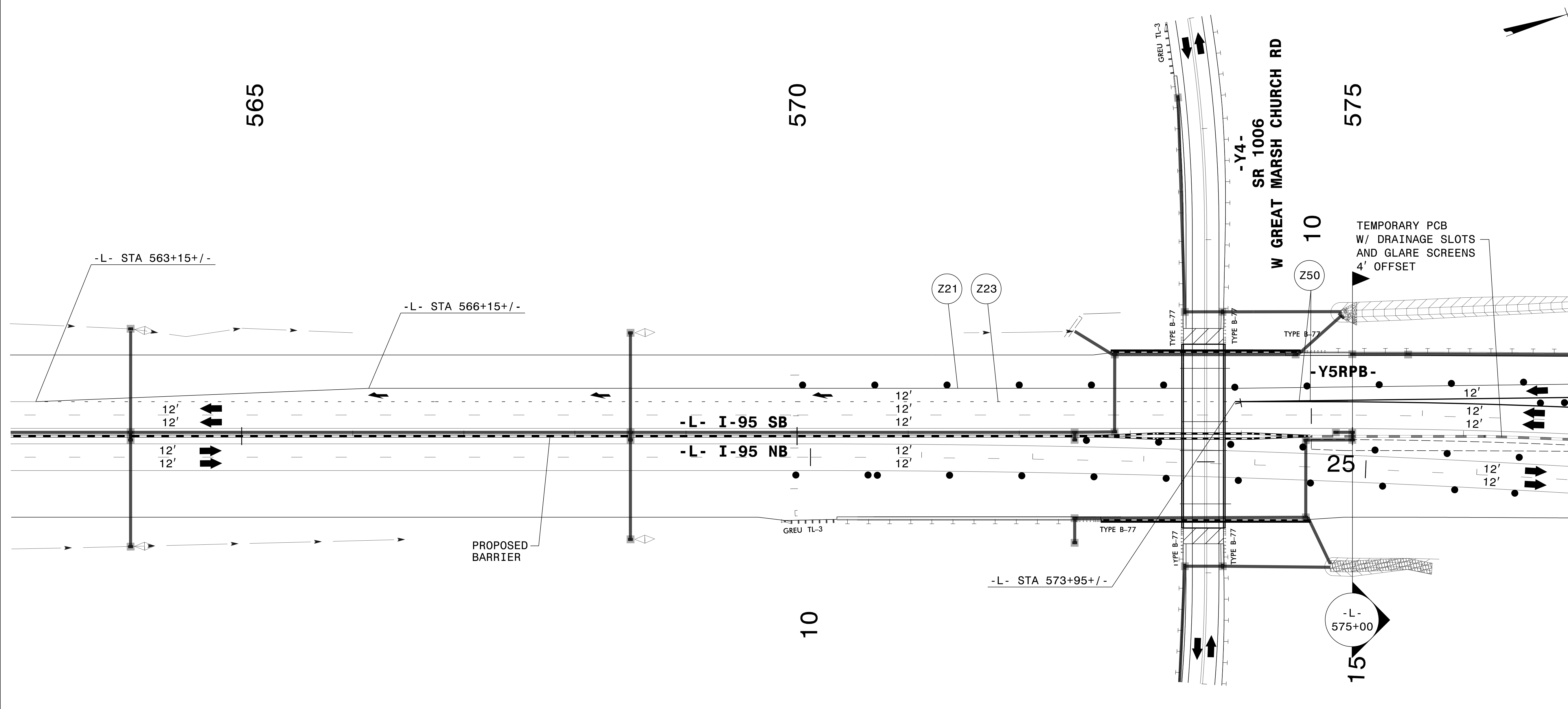
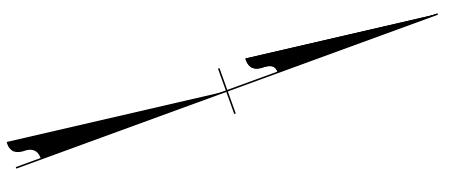

3/29/2022
 G:\50100191\NV5_I-5987B\TrafficControl\Top\200_473_I-5987B_TMP-103_Phase IV Step 3_10.dgn
 User:ST086227

APPROVED: _____
 DATE: _____

**DOCUMENT NOT CONSIDERED FINAL
 UNLESS ALL SIGNATURES COMPLETED**

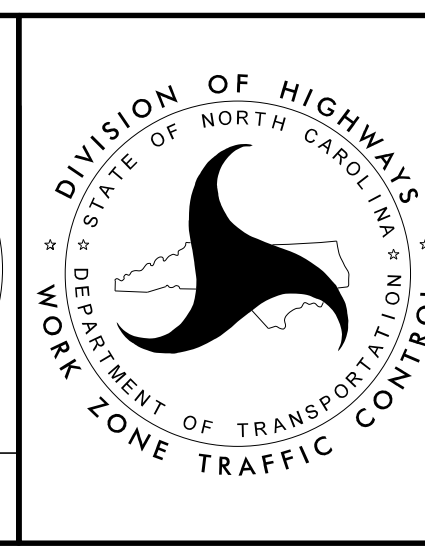

SECTION 1

**TEMPORARY TRAFFIC CONTROL
 PHASE IV, STEP 3**

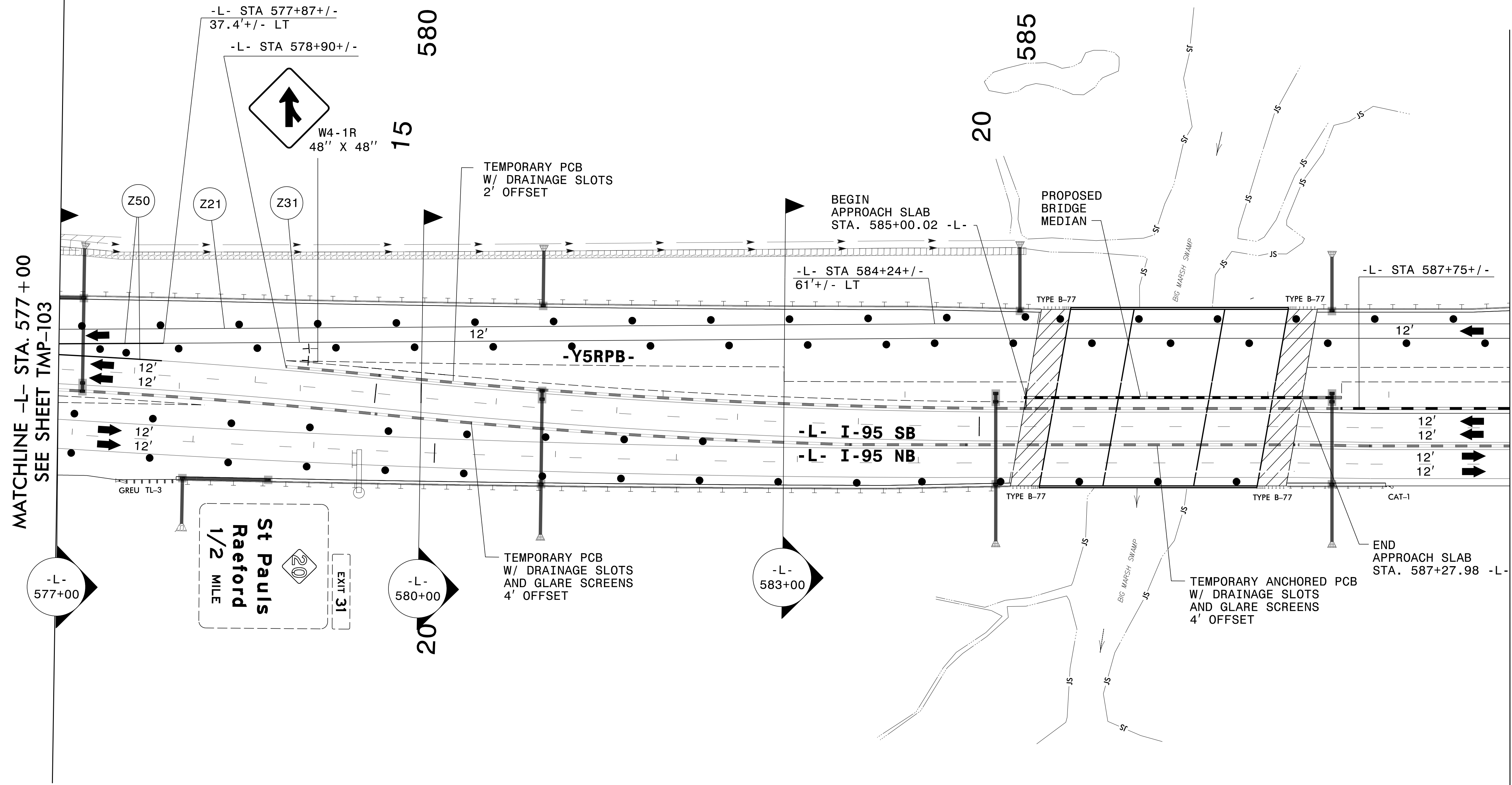
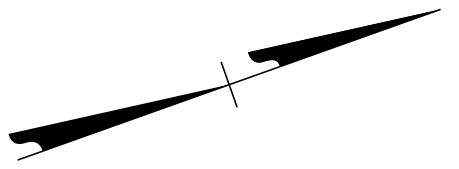

3/29/2022 G:\50100191\NV5_1-5987B\TrafficControl\Top\200_475_1-5987B-TMP-104_Phase IV_Step 3_1.dgn User:ST086227

SEE SHEET TMP-104A FOR SECTIONS

APPROVED: _____
DATE: _____

DOCUMENT NOT CONSIDERED FINAL UNLESS ALL SIGNATURES COMPLETED

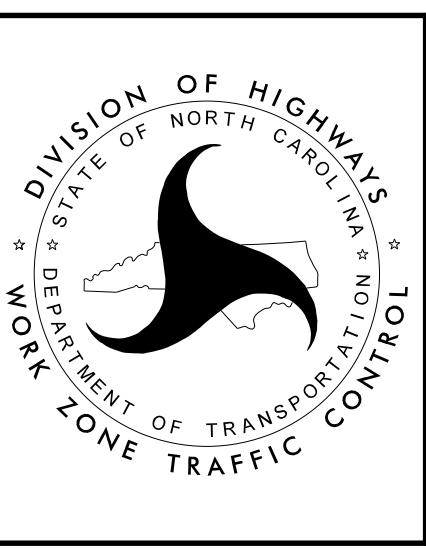

SECTION 1

TEMPORARY TRAFFIC CONTROL PHASE IV, STEP 3

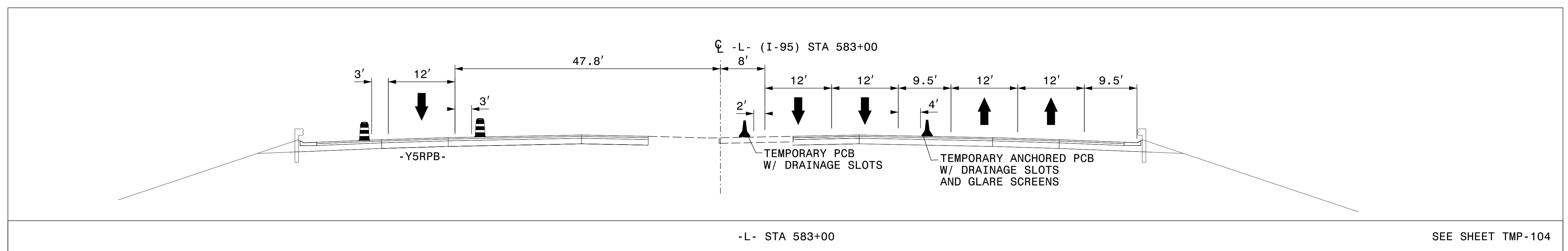
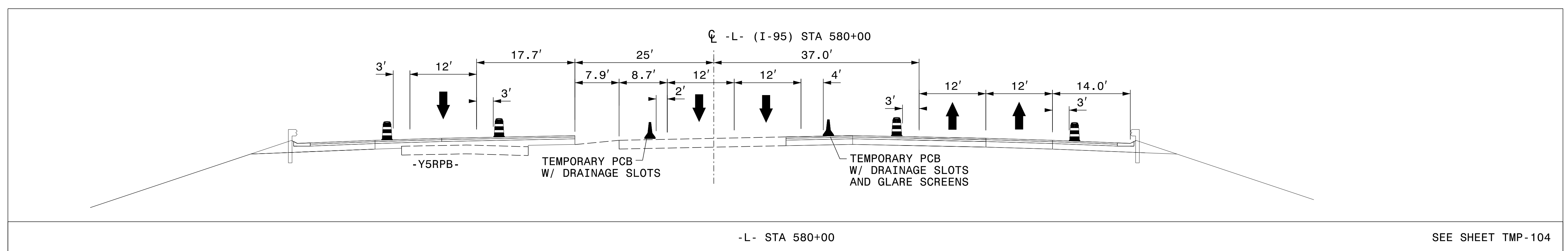
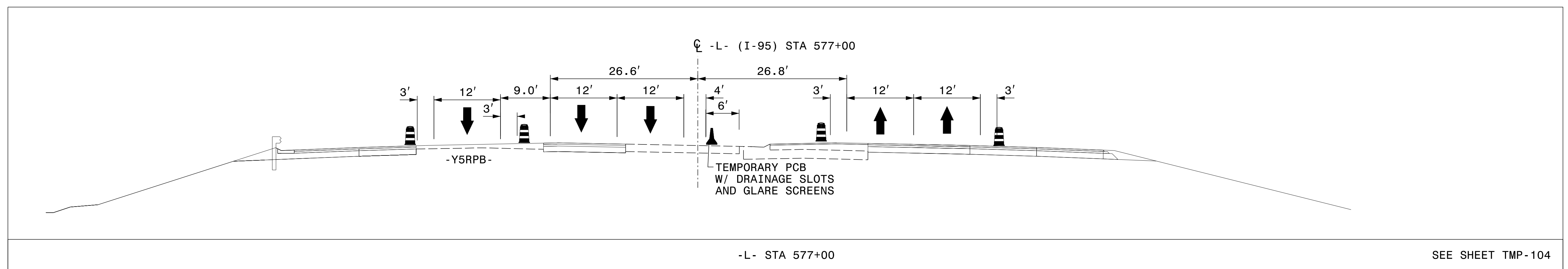

3/29/2022 G:\50100191_NV5_I-5987B\TrafficControl\Tc\200_477_I-5987B-TMP-104A_Phase IV_Step 3.dgn User:ST086227

APPROVED: _____
 DATE: _____

**DOCUMENT NOT CONSIDERED FINAL
 UNLESS ALL SIGNATURES COMPLETED**

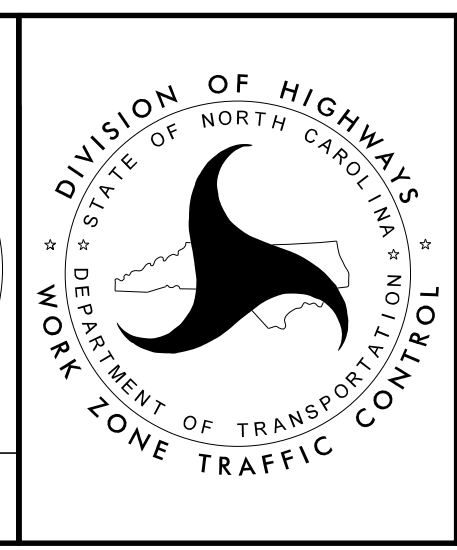

SECTION 1

**TEMPORARY TRAFFIC CONTROL
 PHASE IV, STEP 3**

PLANS PREPARED FOR THE NCDOT BY:

M MOTT MACDONALD I & E, LLC
 1101 HAYNES STREET, SUITE 101
 RALEIGH, NC 27604
M MOTT MACDONALD
 NC LICENSE NO. F-0669

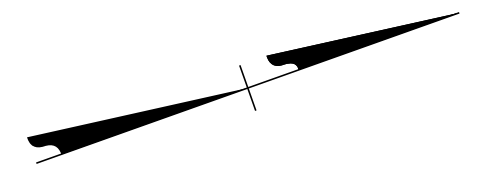
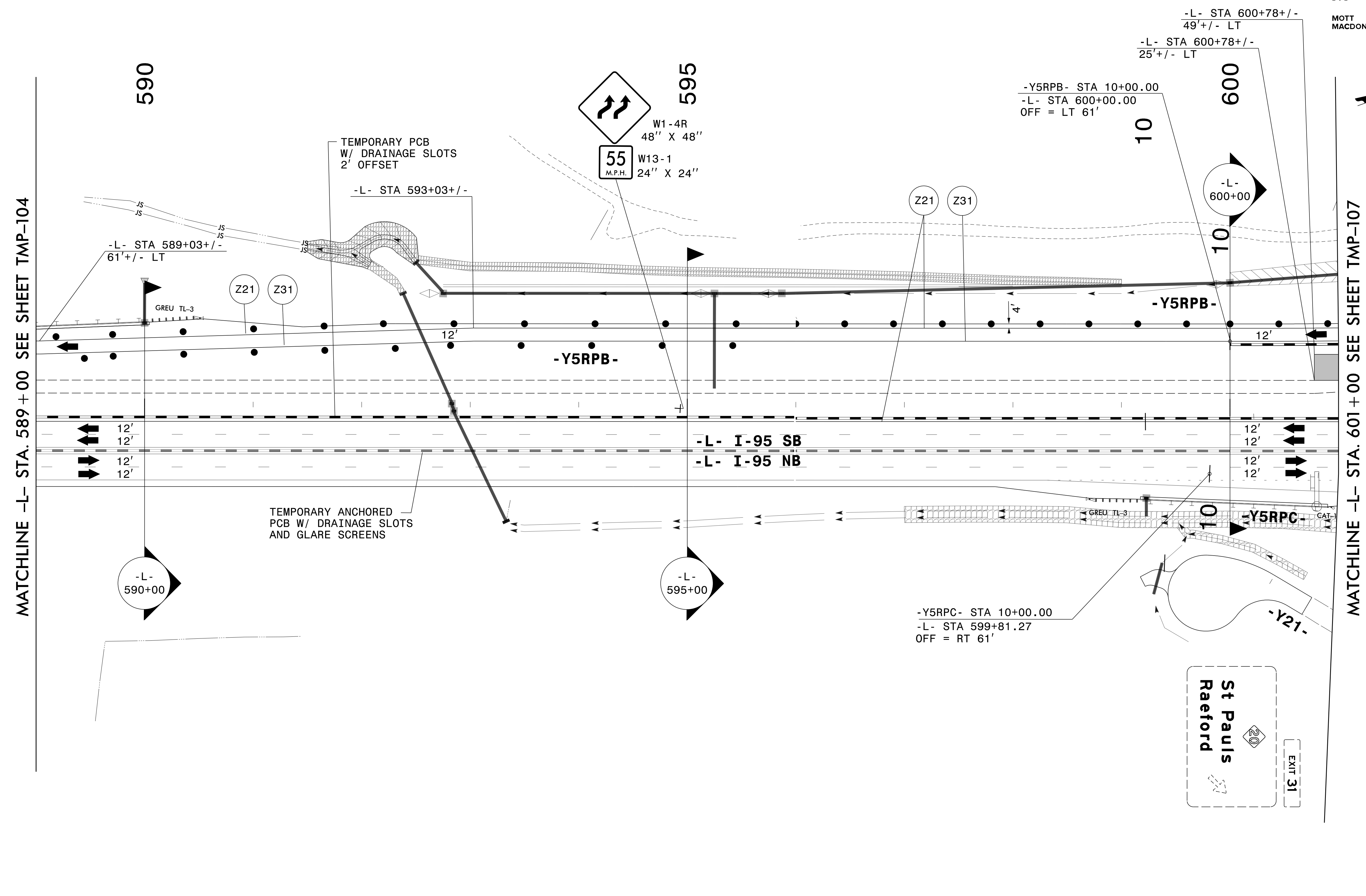

MATCHLINE -L- STA. 589 + 00 SEE SHEET TMP-104

MATCHLINE -L- STA. 601 + 00 SEE SHEET TMP-107

SEE SHEET TMP-106 FOR SECTIONS

APPROVED: _____
 DATE: _____

DOCUMENT NOT CONSIDERED FINAL UNLESS ALL SIGNATURES COMPLETED

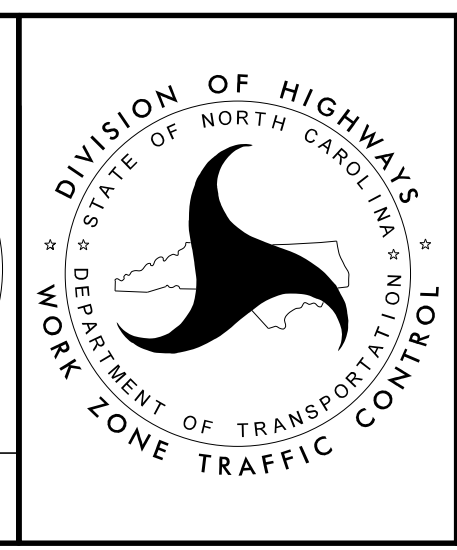

SECTION 1

**TEMPORARY TRAFFIC CONTROL
 PHASE IV, STEP 3**

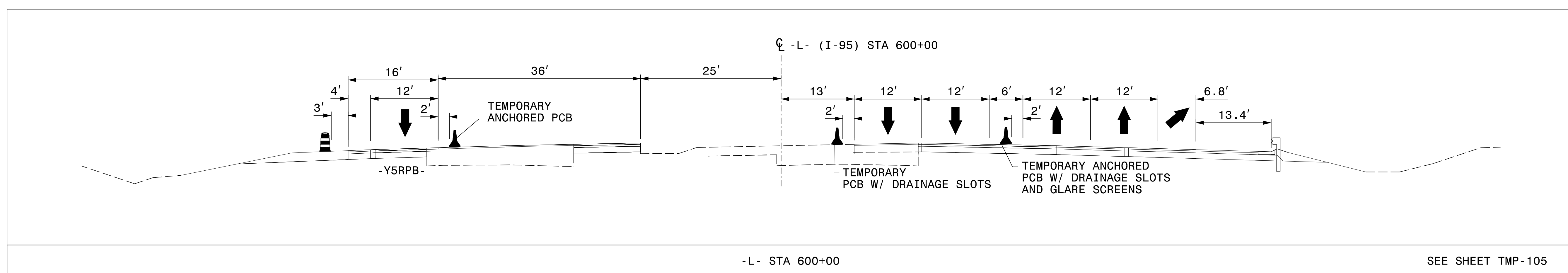
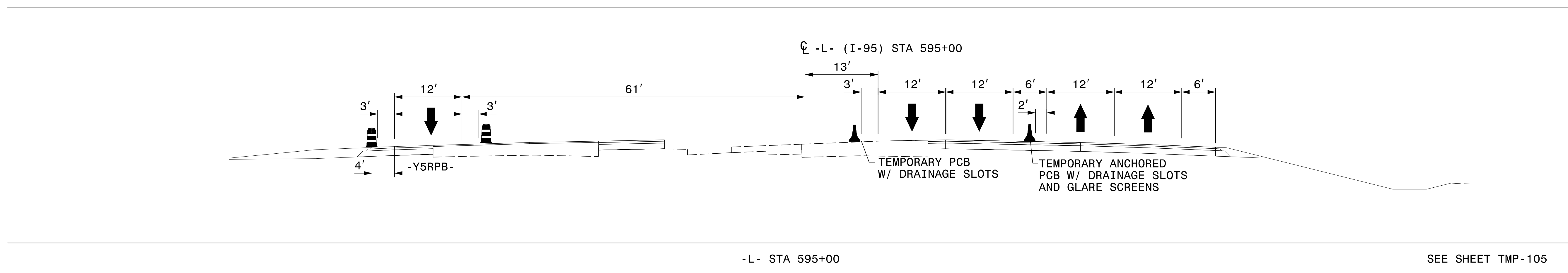
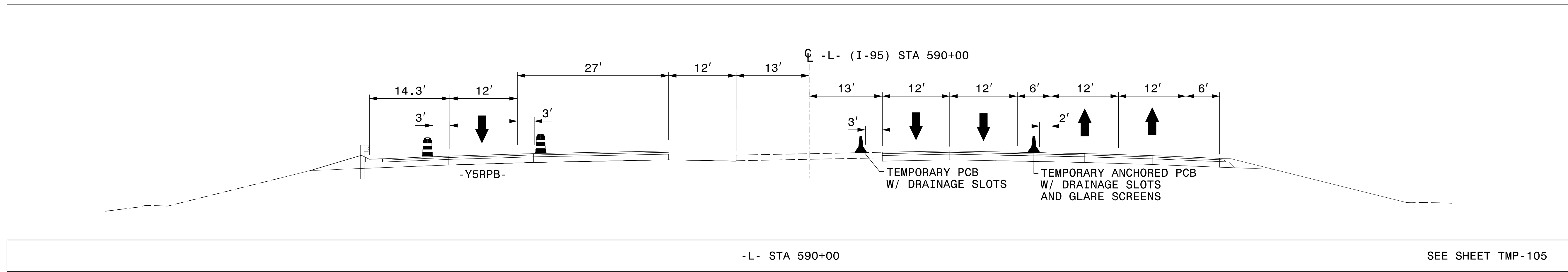

3/29/2022
 G:\50100191\NV5_L-5987B\TrafficControl\Twp\200_481-5987B-TMP-106-Phase IV Step 3.dgn
 User:ST086227

APPROVED: _____
 DATE: _____

**DOCUMENT NOT CONSIDERED FINAL
 UNLESS ALL SIGNATURES COMPLETED**

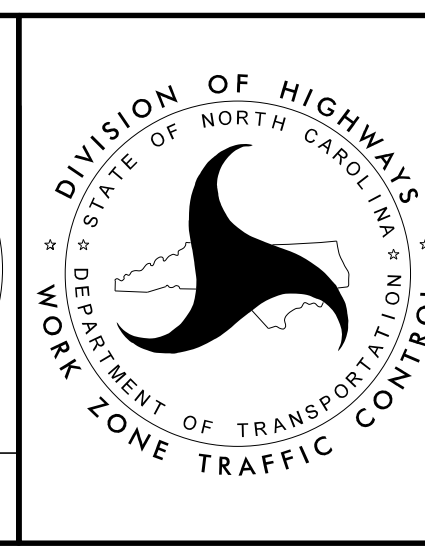

SECTION 1

**TEMPORARY TRAFFIC CONTROL
 PHASE IV, STEP 3**

PROJ. REFERENCE NO.	SHEET NO.
I-5987B	TMP-107

PLANS PREPARED FOR THE NCDOT BY:

M MOTT MACDONALD I & E, LLC
 1101 HAYNES STREET, SUITE 101
 RALEIGH, NC 27604
M MOTT MACDONALD NC LICENSE NO. F-0669

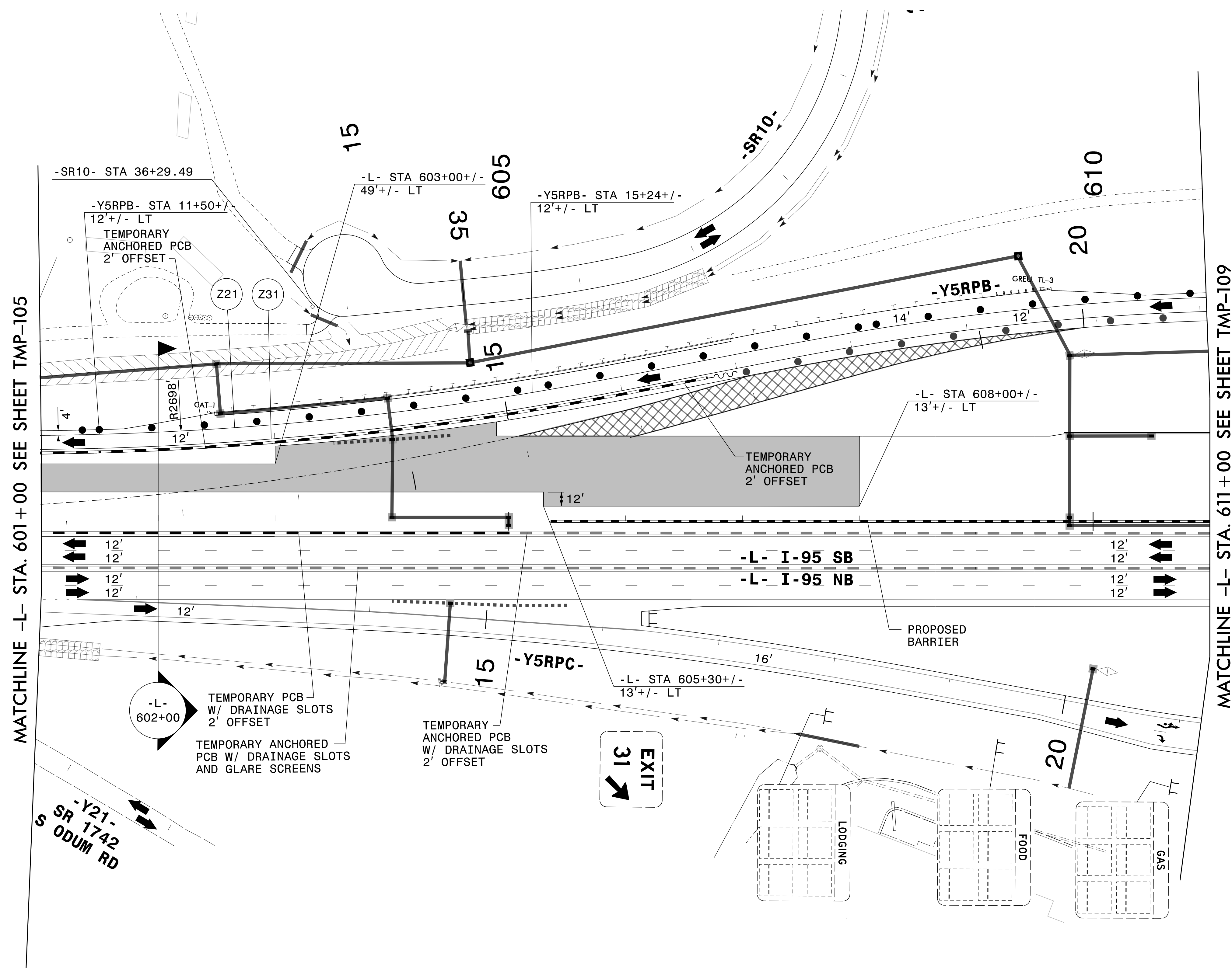
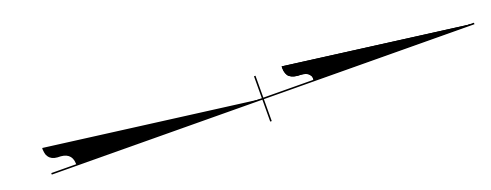

MATCHLINE -L- STA. 601+00 SEE SHEET TMP-105

MATCHLINE -L- STA. 611+00 SEE SHEET TMP-109

SEE SHEET TMP-108 FOR SECTION

APPROVED: _____
 DATE: _____

DOCUMENT NOT CONSIDERED FINAL UNLESS ALL SIGNATURES COMPLETED

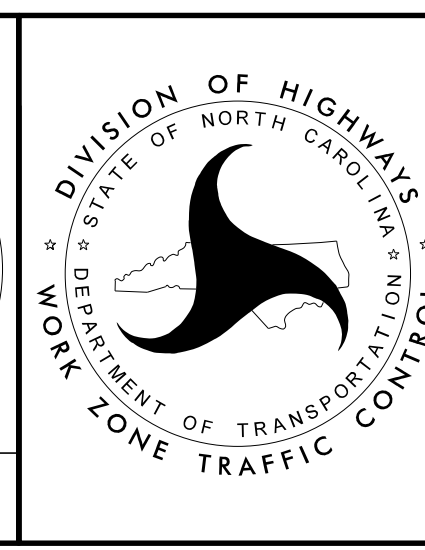

SECTION 1

**TEMPORARY TRAFFIC CONTROL
 PHASE IV, STEP 3**

3/29/2022 G:\50100191\NV5_1-5987B\TrafficControl\Top\200_483_1-5987B-TMP-107_Phase IV_Step 3_13.dgn User:ST086227

PROJ. REFERENCE NO.	SHEET NO.
I-5987B	TMP-108

PLANS PREPARED FOR THE NCDOT BY:

M MOTT MACDONALD I & E, LLC
 1101 HAYNES STREET, SUITE 101
 RALEIGH, NC 27604
M NC LICENSE NO. F-0669
 MOTT MACDONALD

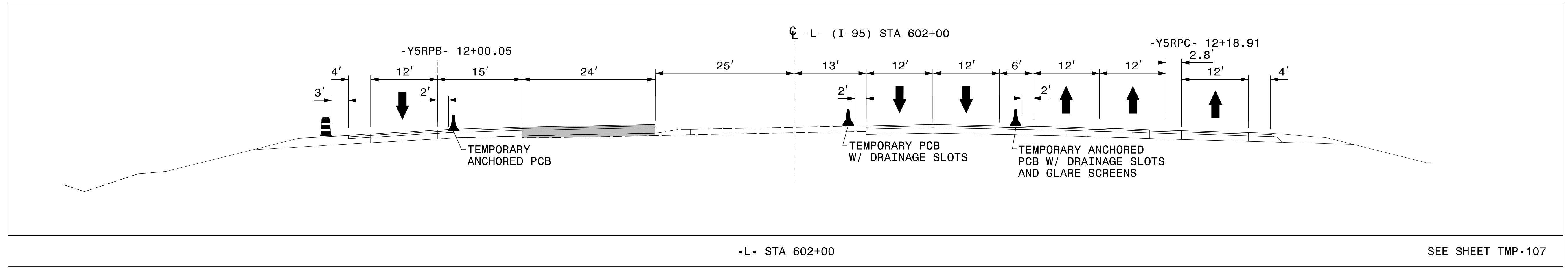

3/29/2022
 G:\50100191\NV5_I-5987B\TrafficControl\Top\200_485_I-5987B_TMP-108_Phase IV_Step 3_13.dgn
 User:ST086227

APPROVED: _____			SECTION 1
DATE: _____			TEMPORARY TRAFFIC CONTROL PHASE IV, STEP 3
DOCUMENT NOT CONSIDERED FINAL UNLESS ALL SIGNATURES COMPLETED			

PLANS PREPARED FOR THE NCDOT BY:
M MOTT MACDONALD I & E, LLC
 1101 HAYNES STREET, SUITE 101
 RALEIGH, NC 27604
 NC LICENSE NO. F-0669

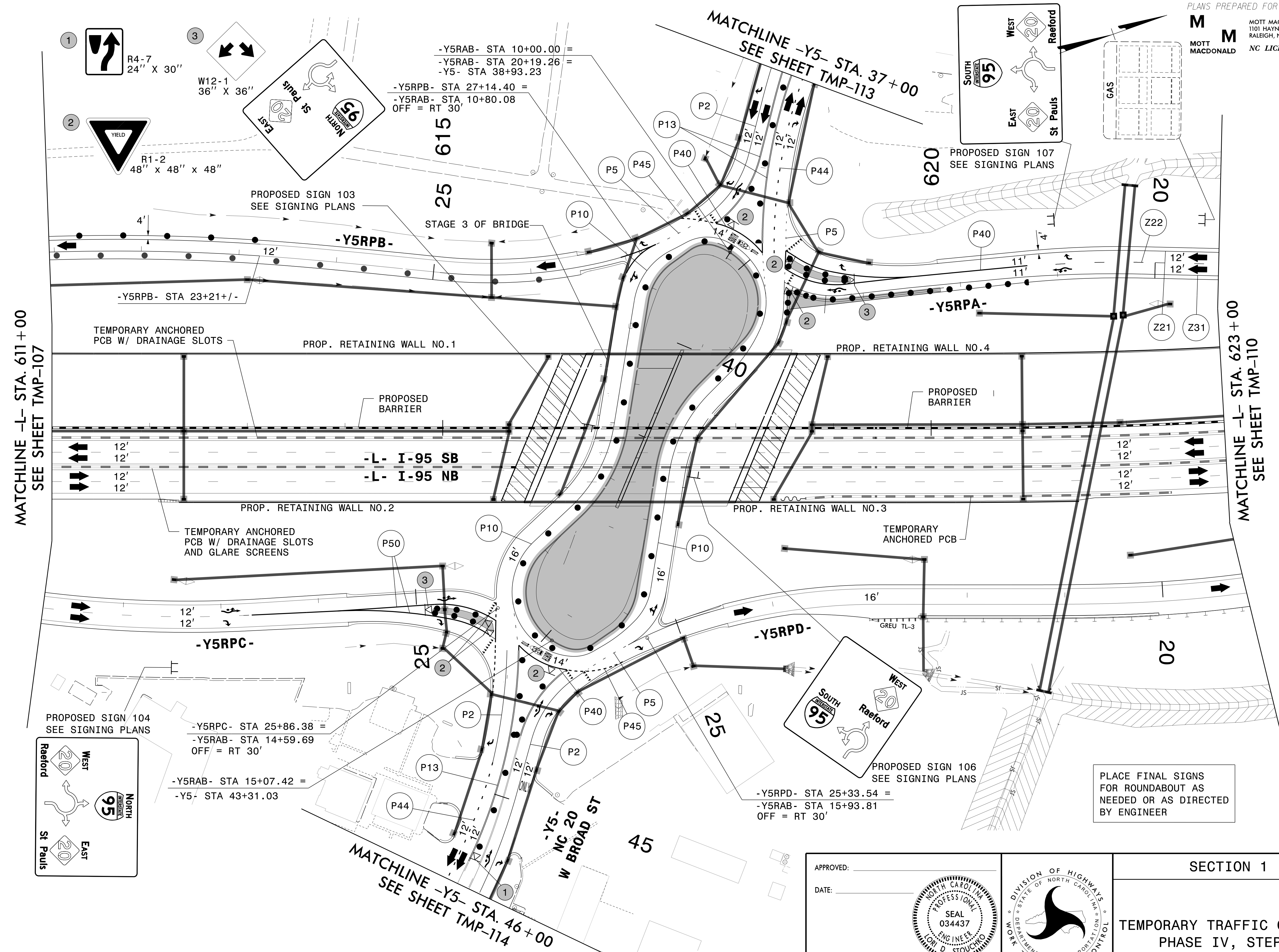

MATCHLINE -L- STA. 611+00
SEE SHEET TMP-107

MATCHLINE -L- STA. 623+00
SEE SHEET TMP-110

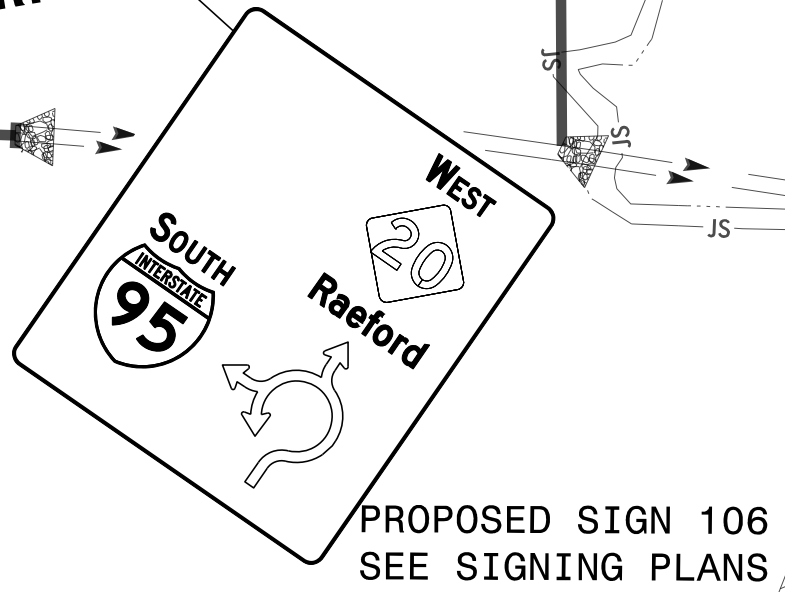
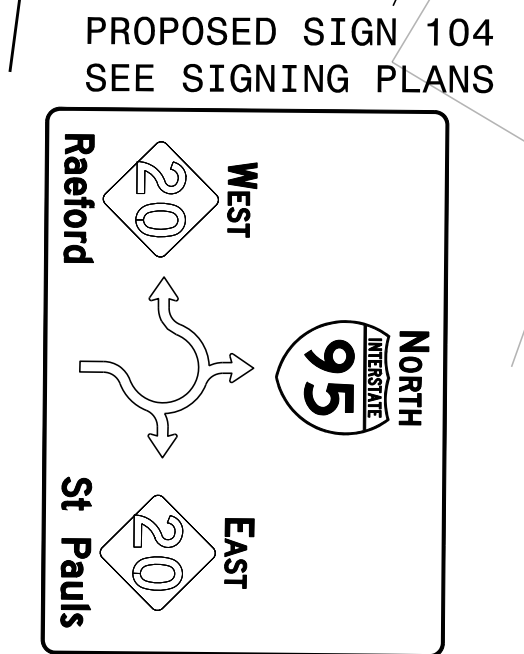

PLACE FINAL SIGNS FOR ROUNDABOUT AS NEEDED OR AS DIRECTED BY ENGINEER

APPROVED: _____
 DATE: _____

DOCUMENT NOT CONSIDERED FINAL UNLESS ALL SIGNATURES COMPLETED



SECTION 1

**TEMPORARY TRAFFIC CONTROL
 PHASE IV, STEP 3**

3/29/2022
 G:\50100191\NV5_I-5987B\TrafficControl\Twp\200_487_I-5987B-TMP-109_Phase IV_Step 3_14.dgn
 User:ST086227

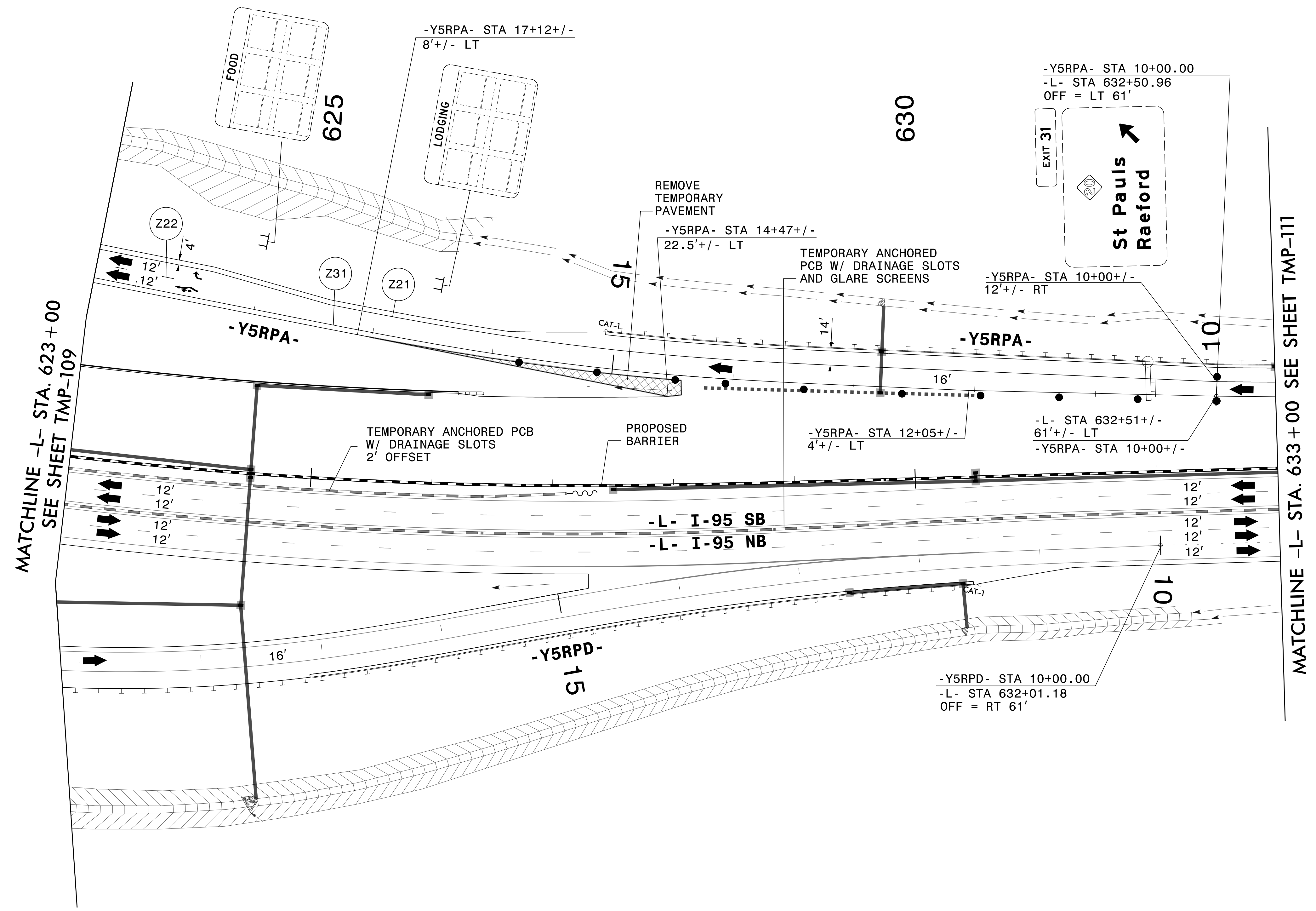
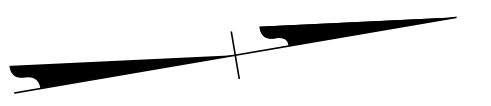

3/29/2022
G:\50100191\NV5_L-5987B\TrafficControl\Tcpl\200_489_L-5987B-TMP-110_Phase IV_Step 3.dgn
User:ST086227

APPROVED: _____
DATE: _____

SEAL
034437
ENGINEER
LORI D. STOUCHINO

**DOCUMENT NOT CONSIDERED FINAL
UNLESS ALL SIGNATURES COMPLETED**

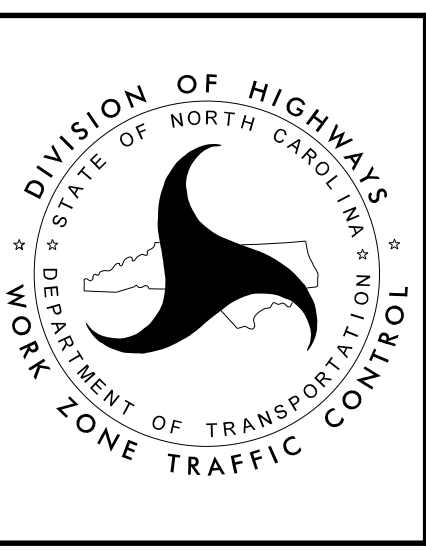

SECTION 1

**TEMPORARY TRAFFIC CONTROL
PHASE IV, STEP 3**

PROJ. REFERENCE NO.	SHEET NO.
I-5987B	TMP-111

PLANS PREPARED FOR THE NCDOT BY:

M MOTT MACDONALD I & E, LLC
1101 HAYNES STREET, SUITE 101
RALEIGH, NC 27604
M MOTT MACDONALD NC LICENSE NO. F-0669

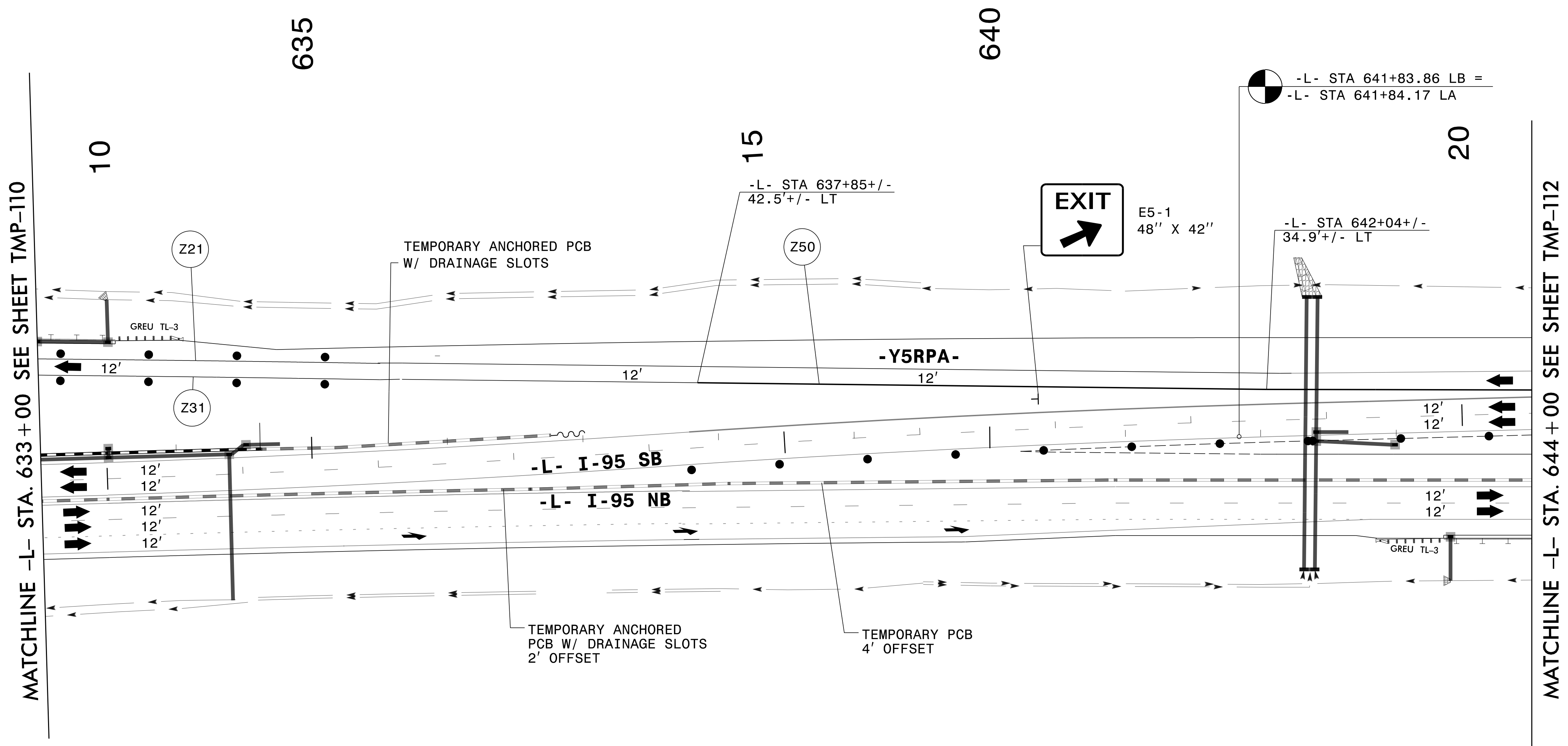
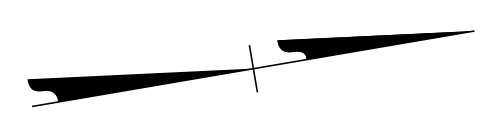

3/29/2022 G:\50100191\NV5_L-5987B\TrafficControl\Top\200_491_L-5987B_TMP-III_Phase IV_Step 3_16.dgn User:ST086227

APPROVED: _____
DATE: _____

**DOCUMENT NOT CONSIDERED FINAL
UNLESS ALL SIGNATURES COMPLETED**

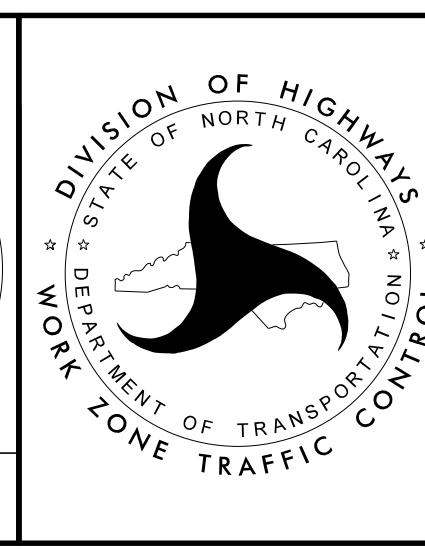

SECTION 1

**TEMPORARY TRAFFIC CONTROL
PHASE IV, STEP 3**

PROJ. REFERENCE NO.	SHEET NO.
I-5987B	TMP-112

PLANS PREPARED FOR THE NCDOT BY:

M MOTT MACDONALD I & E, LLC
 1101 HAYNES STREET, SUITE 101
 RALEIGH, NC 27604
M MOTT MACDONALD
 NC LICENSE NO. F-0669

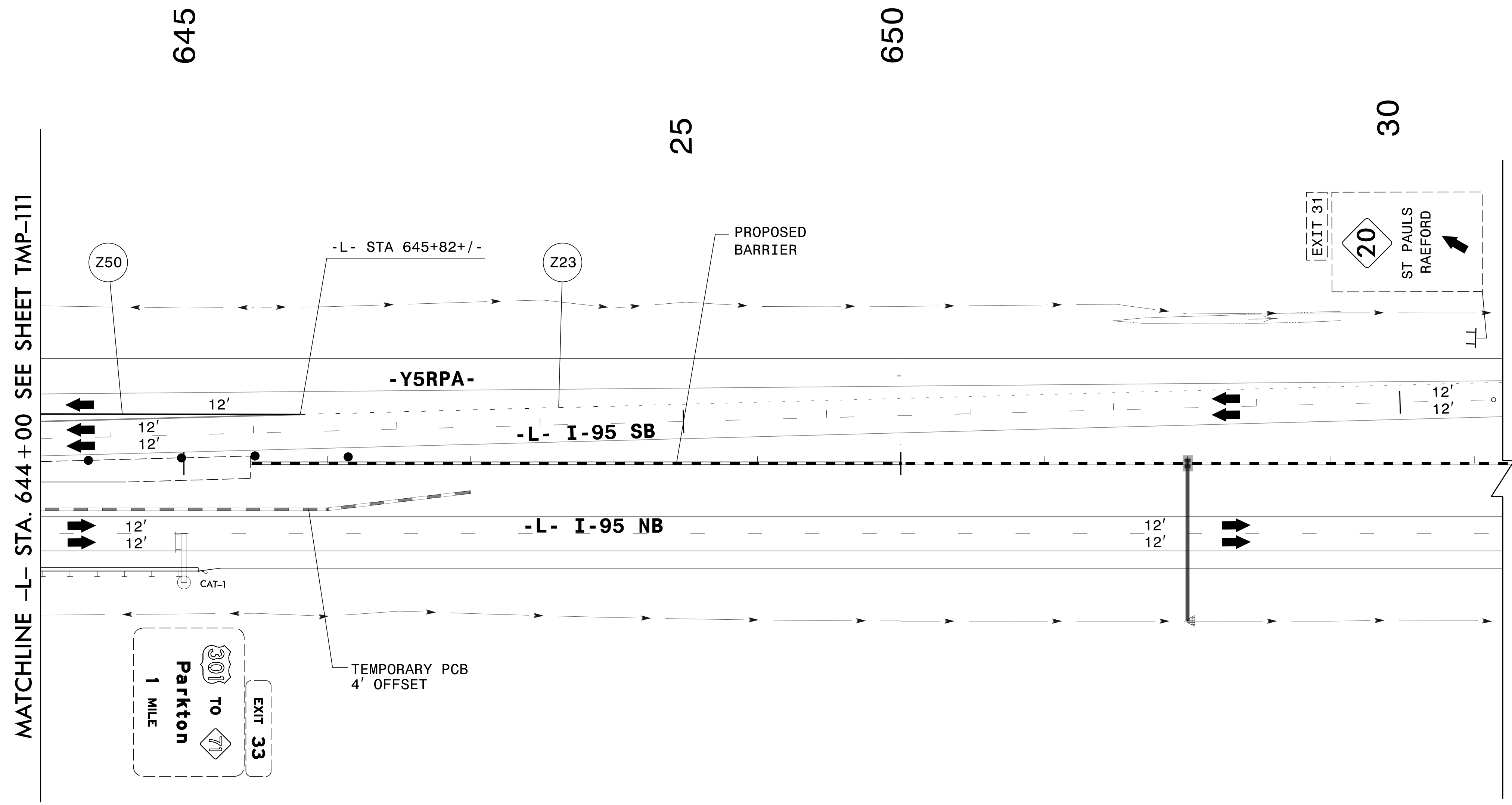
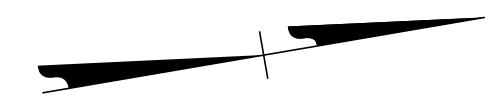

3/29/2022
 G:\50100191\NV5_1-5987B\TrafficControl\Top\200_493_1-5987B-TMP-112_Phase IV_Step 3.dgn
 User:ST086227

APPROVED: _____
 DATE: _____

**DOCUMENT NOT CONSIDERED FINAL
 UNLESS ALL SIGNATURES COMPLETED**

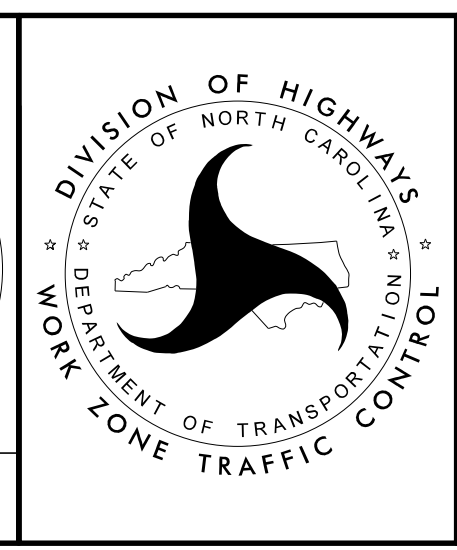

SECTION 1

**TEMPORARY TRAFFIC CONTROL
 PHASE IV, STEP 3**

PLANS PREPARED FOR THE NCDOT BY:

M MOTT MACDONALD I & E, LLC
 1101 HAYNES STREET, SUITE 101
 RALEIGH, NC 27604
M MOTT MACDONALD NC LICENSE NO. F-0669

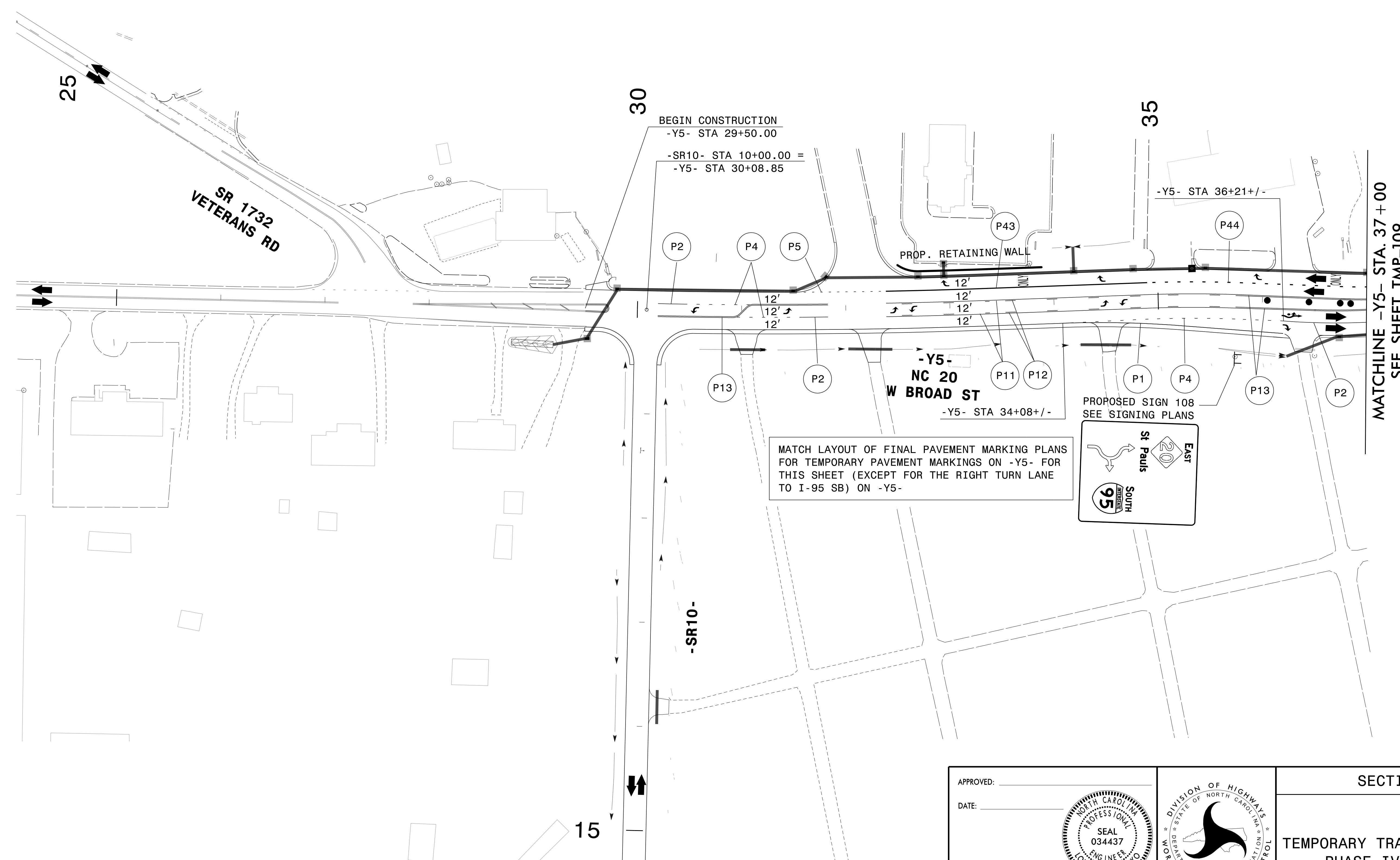
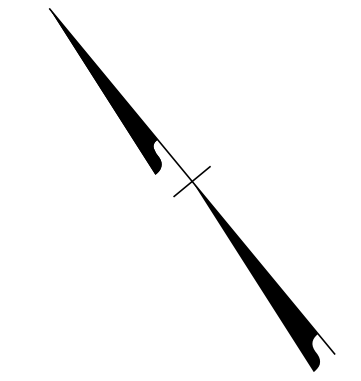

3/29/2022
 G:\50100191_INV5_I-5987B\TrafficControl\Top\200_495_I-5987B_TMP-113_Phase IV_Step 3_Y5.dgn
 User:ST086227

APPROVED: _____

DATE: _____

**DOCUMENT NOT CONSIDERED FINAL
 UNLESS ALL SIGNATURES COMPLETED**

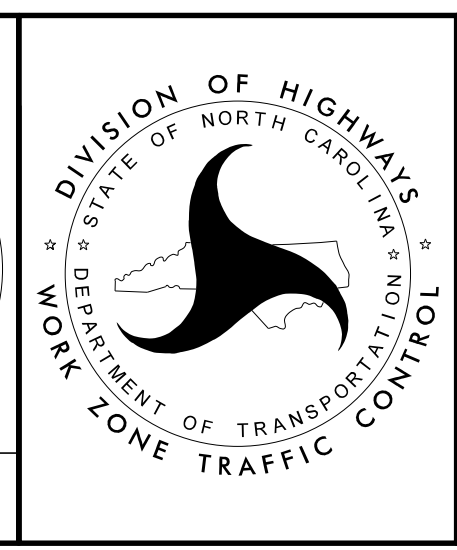

SECTION 1

**TEMPORARY TRAFFIC CONTROL
 PHASE IV, STEP 3**

PROJ. REFERENCE NO.	SHEET NO.
I-5987B	TMP-114

PLANS PREPARED FOR THE NCDOT BY:

M MOTT MACDONALD I & E, LLC
 1101 HAYNES STREET, SUITE 101
 RALEIGH, NC 27604
M MOTT MACDONALD NC LICENSE NO. F-0669

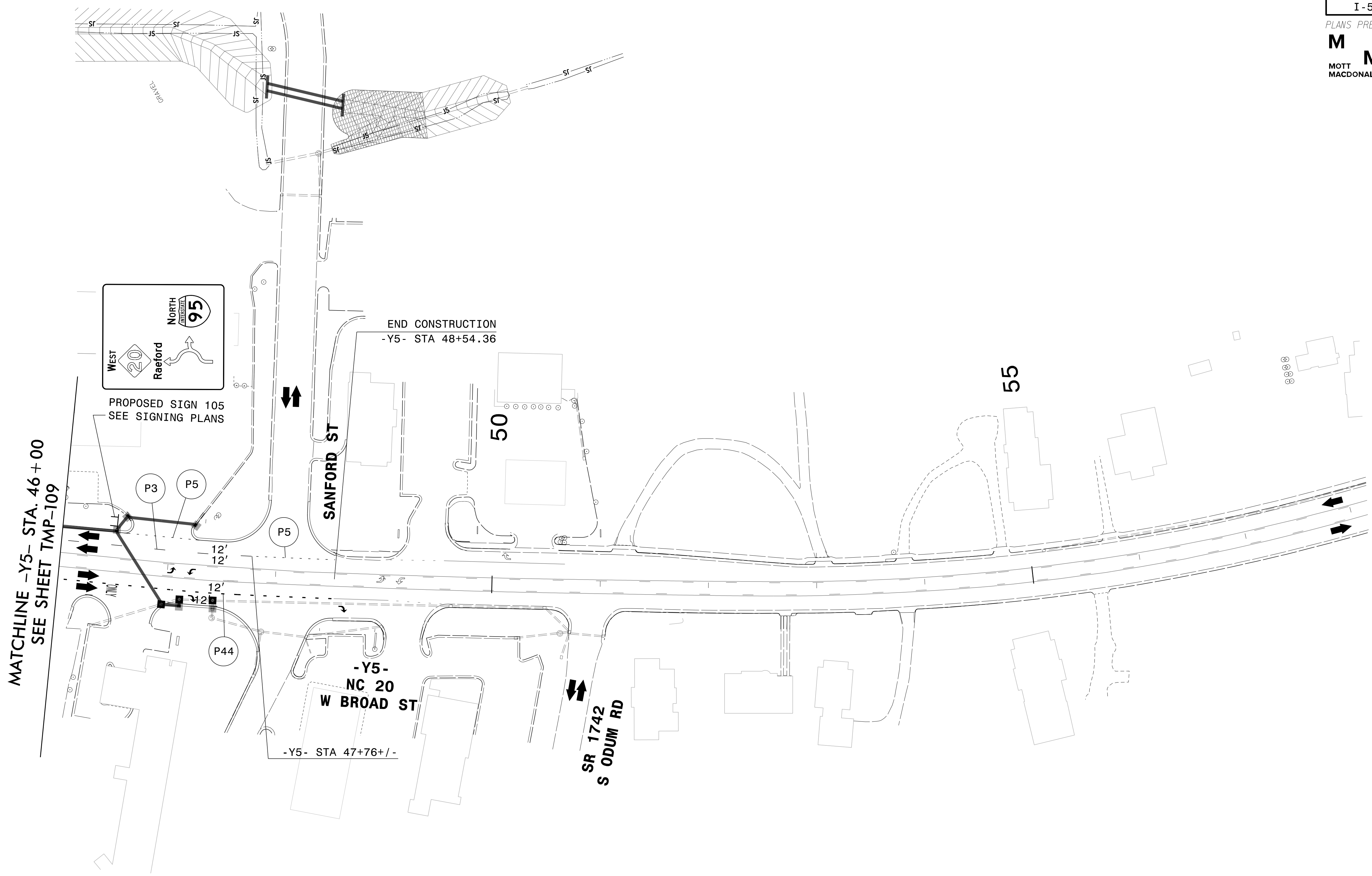
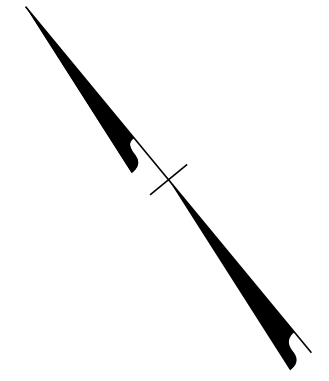

3/29/2022
 G:\50100191\NV5_1-5987B\TrafficControl\Tc\200_497_1-5987B-TMP-114_Phase IV_Step 3_Y5.dgn
 User:ST086227

APPROVED: _____
 DATE: _____

**DOCUMENT NOT CONSIDERED FINAL
 UNLESS ALL SIGNATURES COMPLETED**

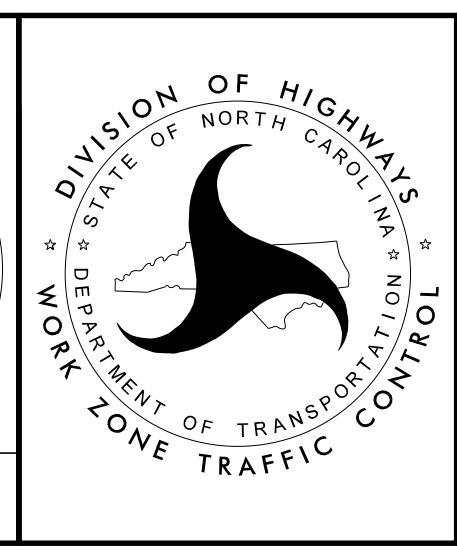

SECTION 1

**TEMPORARY TRAFFIC CONTROL
 PHASE IV, STEP 3**

PROJ. REFERENCE NO.	SHEET NO.
I-5987B	TMP-115

PLANS PREPARED FOR THE NCDOT BY:

M MOTT MACDONALD I & E, LLC
 1101 HAYNES STREET, SUITE 101
 RALEIGH, NC 27604
M MOTT MACDONALD NC LICENSE NO. F-0669

NOTE: THE WORK SHOWN IN I-5987B PHASE V IS TO BE COORDINATED WITH WORK SHOWN IN I-5987A PHASE V

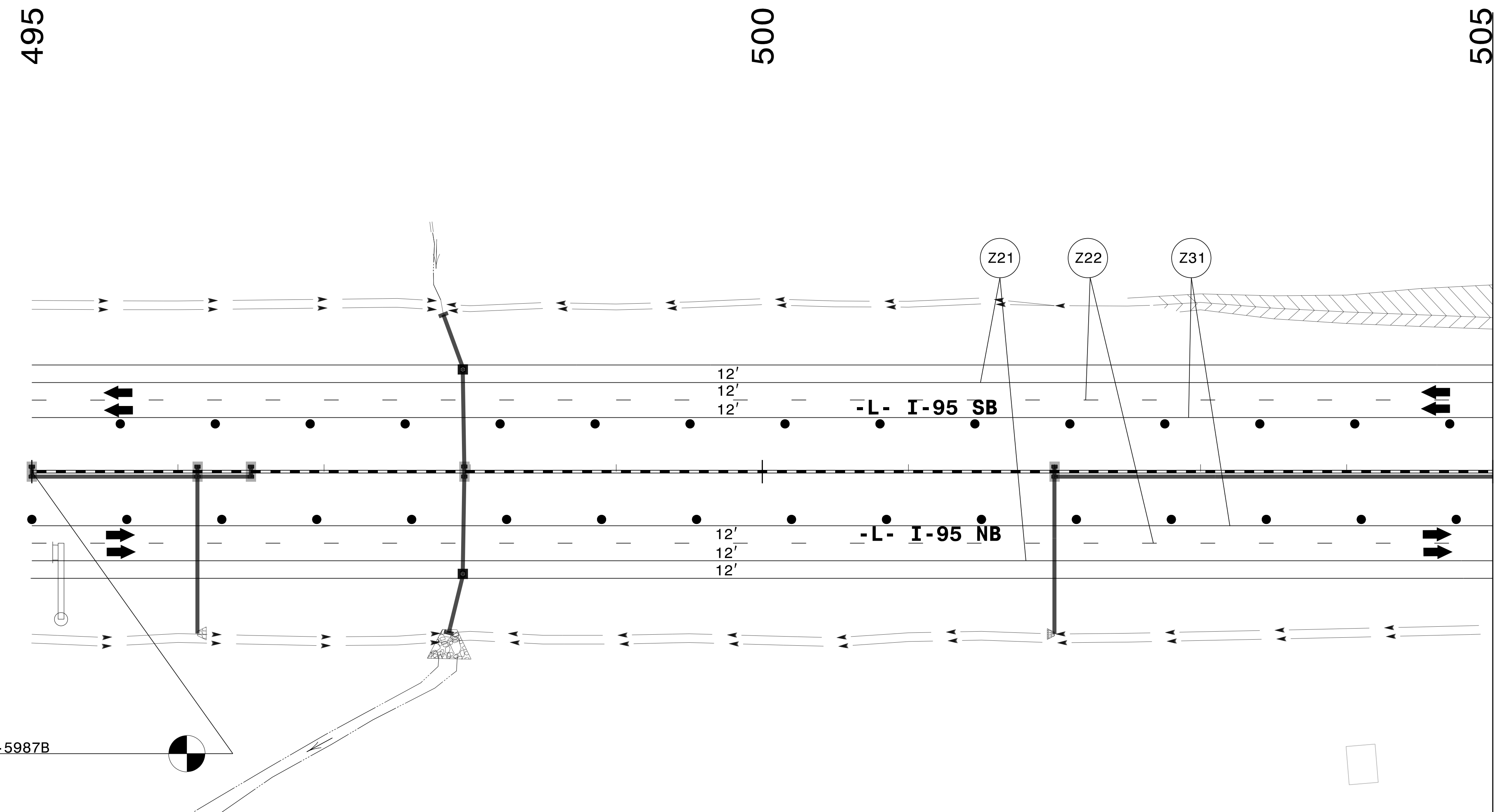
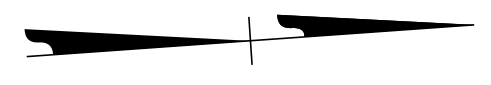

MATCHLINE -L- STA. 505+00 SEE SHEET TMP-116

BEGIN TIP PROJECT I-5987B
 -L- STA 495+00.00

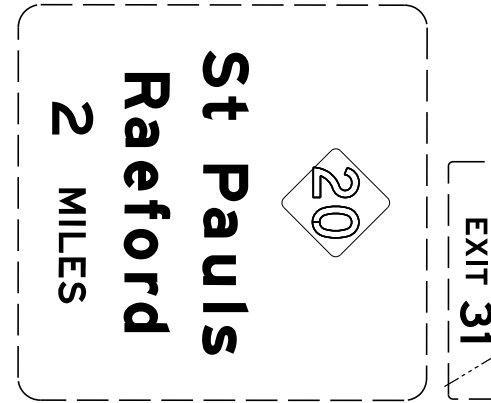

APPROVED: _____
 DATE: _____

**DOCUMENT NOT CONSIDERED FINAL
 UNLESS ALL SIGNATURES COMPLETED**

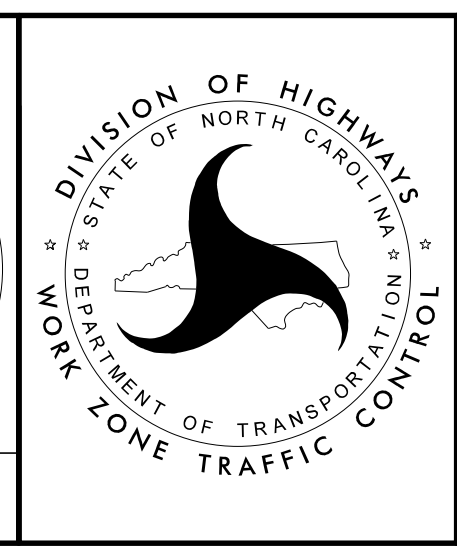

SECTION 1

**TEMPORARY TRAFFIC CONTROL
 PHASE V**

3/29/2022
 G:\50100191\NV5_I-5987B\TrafficControl\Tc\200_499_I-5987B-TMP-115_Phase V_4.dgn
 User:ST086227

PROJ. REFERENCE NO.	SHEET NO.
I-5987B	TMP-116

PLANS PREPARED FOR THE NCDOT BY:

M MOTT MACDONALD I & E, LLC
 1101 HAYNES STREET, SUITE 101
 RALEIGH, NC 27604
M MOTT MACDONALD NC LICENSE NO. F-0669

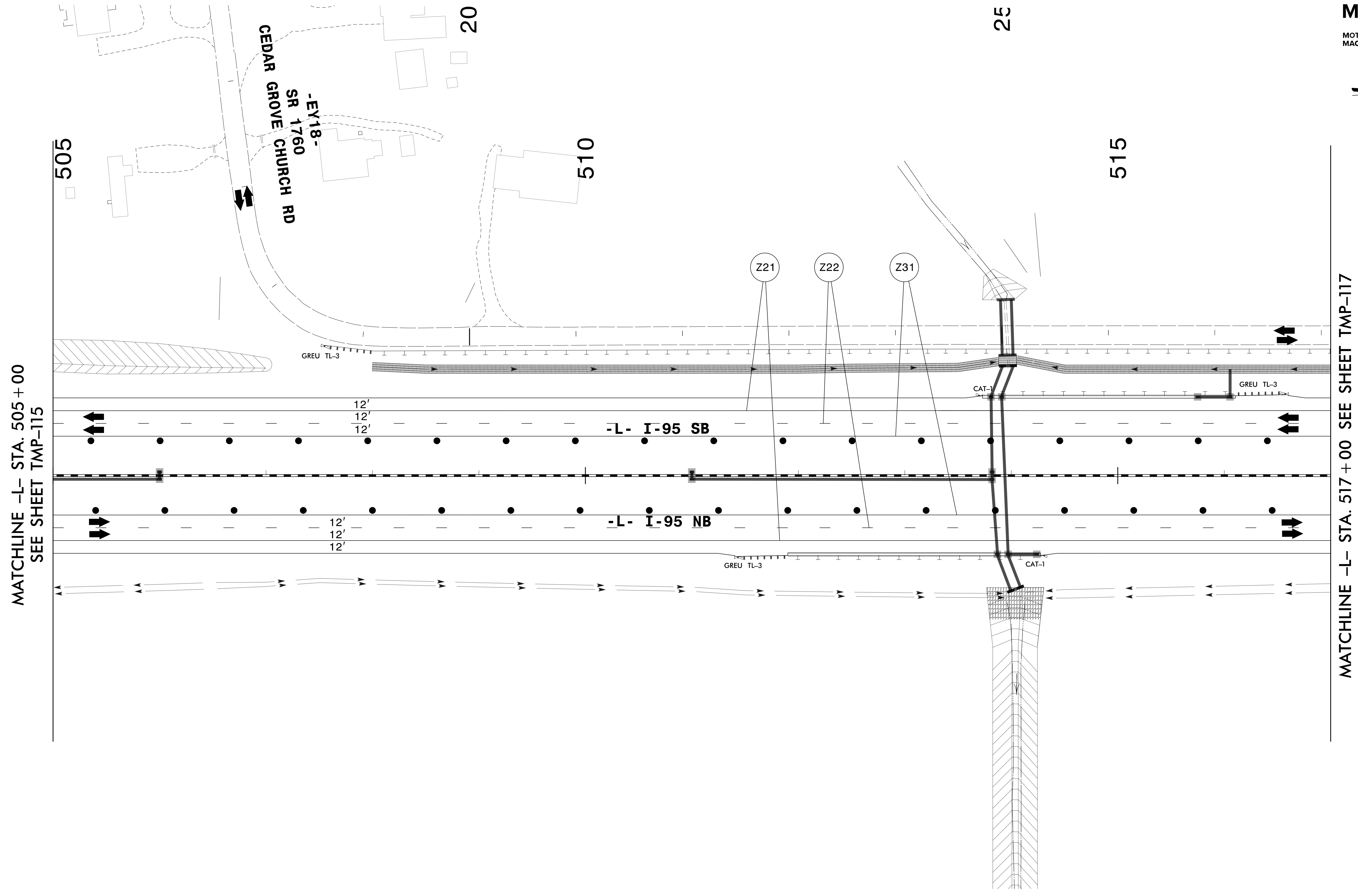

MATCHLINE -L- STA. 505+00
SEE SHEET TMP-115

MATCHLINE -L- STA. 517+00 SEE SHEET TMP-117

3/29/2022
 G:\50100191\NV5_L-5987B\TrafficControl\Tep\200_501_L-5987B_TMP-116_Phase V_5.dgn
 User:ST086227

APPROVED: _____
 DATE: _____

**DOCUMENT NOT CONSIDERED FINAL
 UNLESS ALL SIGNATURES COMPLETED**

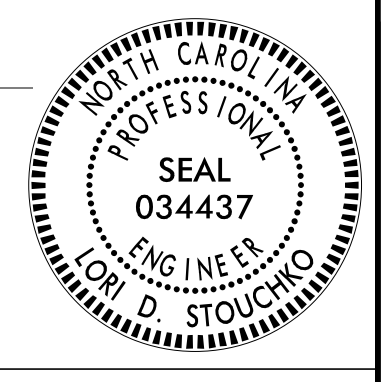

SECTION 1

TEMPORARY TRAFFIC CONTROL
 PHASE V

PROJ. REFERENCE NO.	SHEET NO.
I-5987B	TMP-117

PLANS PREPARED FOR THE NCDOT BY:

M MOTT MACDONALD I & E, LLC
 1101 HAYNES STREET, SUITE 101
 RALEIGH, NC 27604
M MOTT MACDONALD
 NC LICENSE NO. F-0669

40



MATCHLINE -L- STA. 517 +00 SEE SHEET TMP-116

MATCHLINE -L- STA. 529 +00 SEE SHEET TMP-118

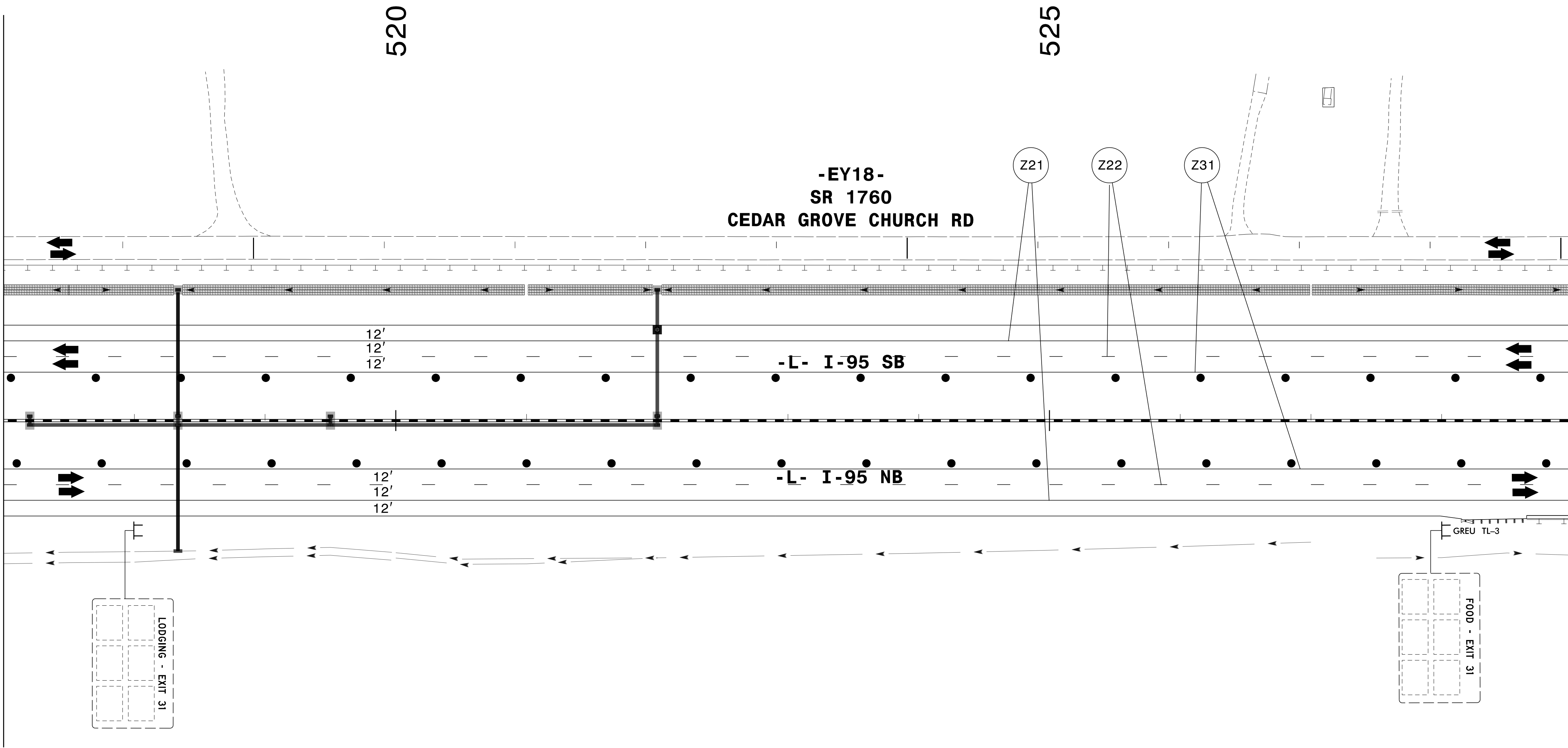

3/29/2022
 G:\50100191\NV5_L-5987B\TrafficControl\Tcpl\200_503_L-5987B-TMP-117_Phase_V_6.dgn
 User:ST086227

APPROVED: _____
 DATE: _____

SEAL
 034437
 ENGINEER
 LORI D. STOUCHE

**DOCUMENT NOT CONSIDERED FINAL
 UNLESS ALL SIGNATURES COMPLETED**

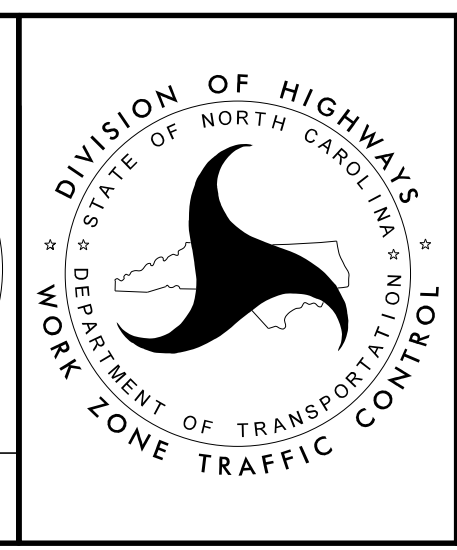

SECTION 1

TEMPORARY TRAFFIC CONTROL
 PHASE V

PROJ. REFERENCE NO.	SHEET NO.
I-5987B	TMP-118

PLANS PREPARED FOR THE NCDOT BY:

M MOTT MACDONALD I & E, LLC
 1101 HAYNES STREET, SUITE 101
 RALEIGH, NC 27604
M MOTT MACDONALD
 NC LICENSE NO. F-0669

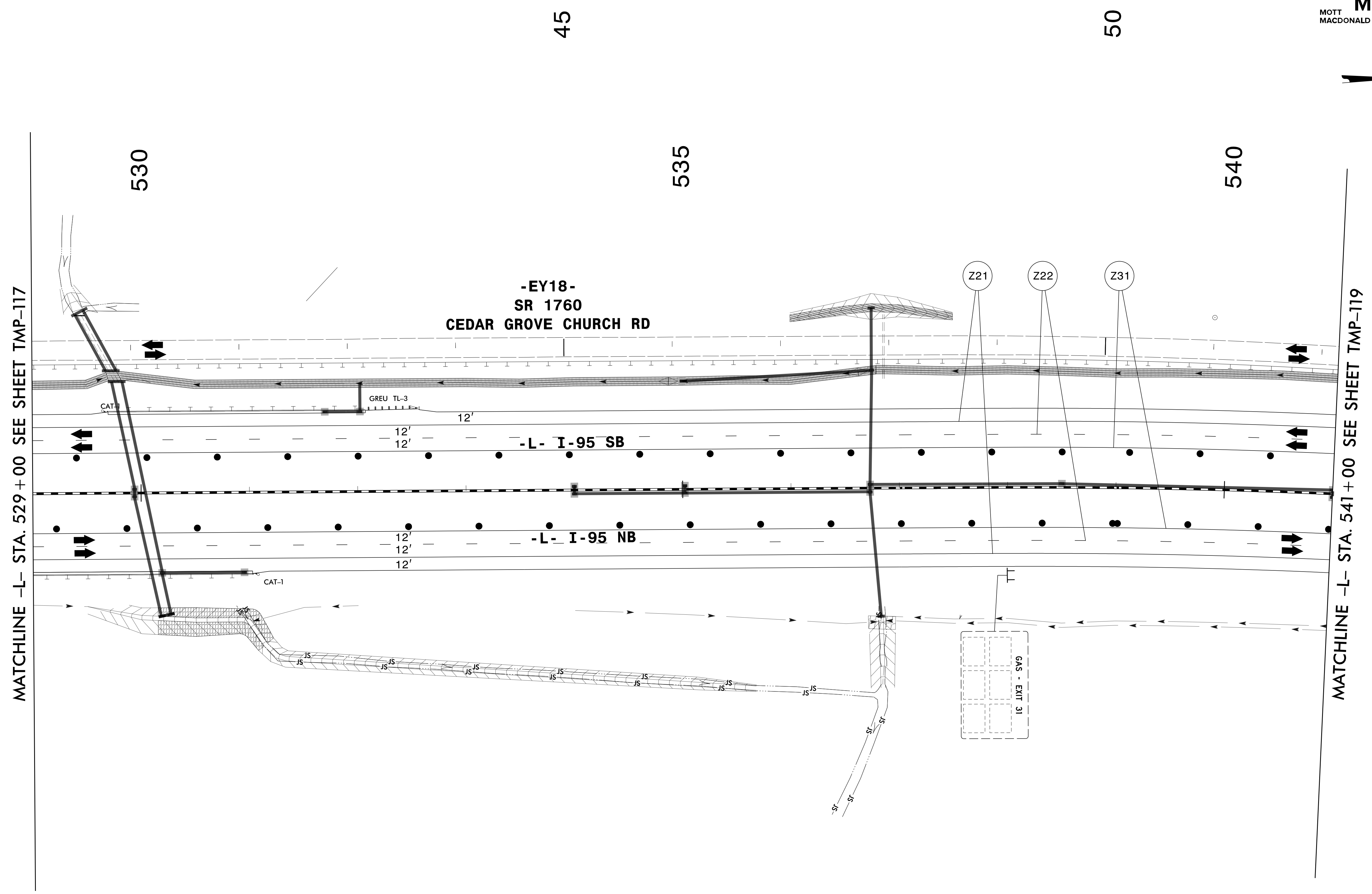

3/29/2022
 G:\50100191\NV5_1-5987B\TrafficControl\Tcpl\200_505_1-5987B-TMP-118_Phase V_1.dgn
 User:ST086227

APPROVED: _____
 DATE: _____

**DOCUMENT NOT CONSIDERED FINAL
 UNLESS ALL SIGNATURES COMPLETED**



SECTION 1

TEMPORARY TRAFFIC CONTROL
 PHASE V

PROJ. REFERENCE NO.	SHEET NO.
I-5987B	TMP-119

PLANS PREPARED FOR THE NCDOT BY:
M MOTT MACDONALD I & E, LLC
 1101 HAYNES STREET, SUITE 101
 RALEIGH, NC 27604
M MOTT MACDONALD
 NC LICENSE NO. F-0669

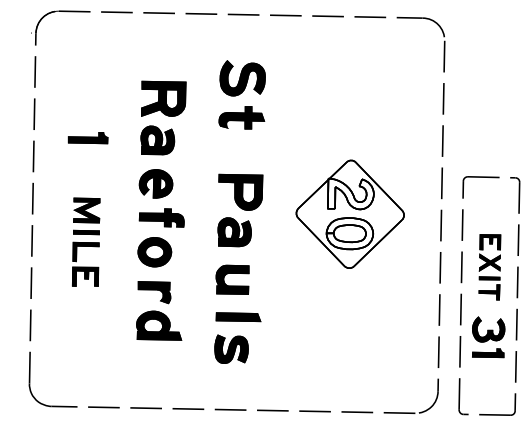
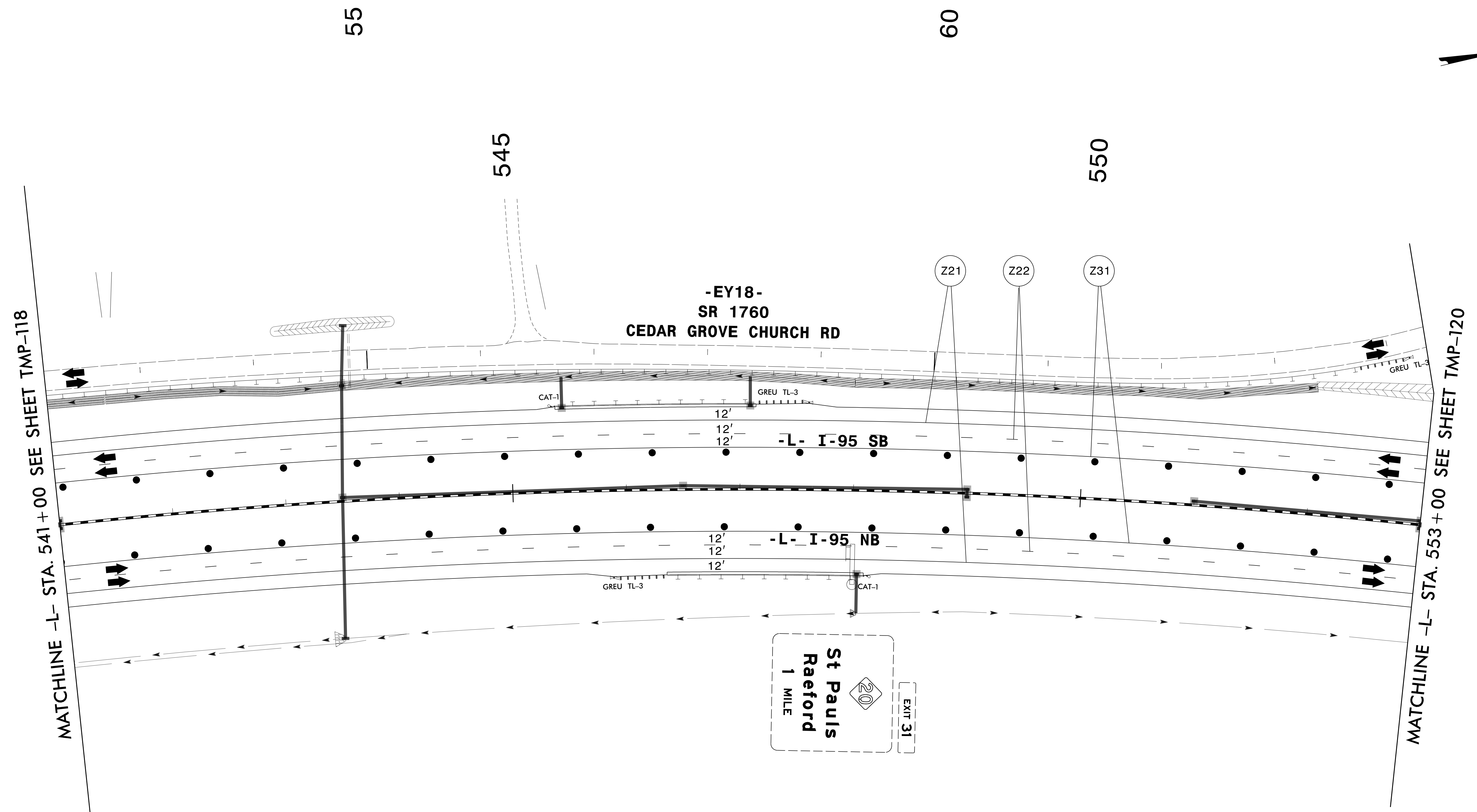
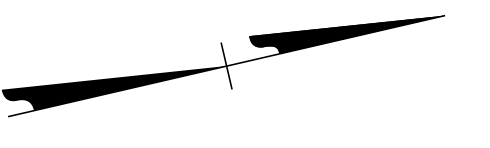

3/29/2022
 G:\50100191\NV5_L-5987B\TrafficControl\Tep\200_507_L-5987B-TMP-119_Phase V_8.dgn
 User:ST086227

APPROVED: _____
 DATE: _____

**DOCUMENT NOT CONSIDERED FINAL
 UNLESS ALL SIGNATURES COMPLETED**

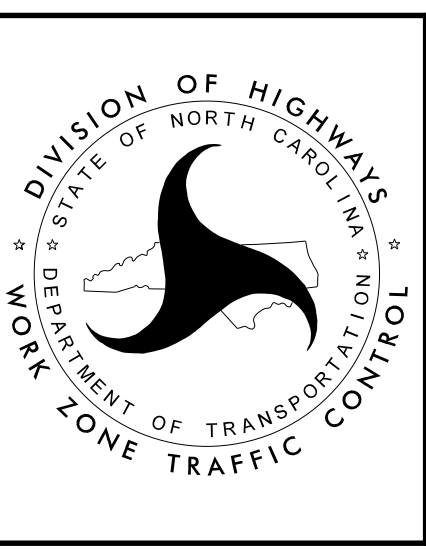

SECTION 1
 TEMPORARY TRAFFIC CONTROL
 PHASE V



PROJ. REFERENCE NO.	SHEET NO.
I-5987B	TMP-120

PLANS PREPARED FOR THE NCDOT BY:

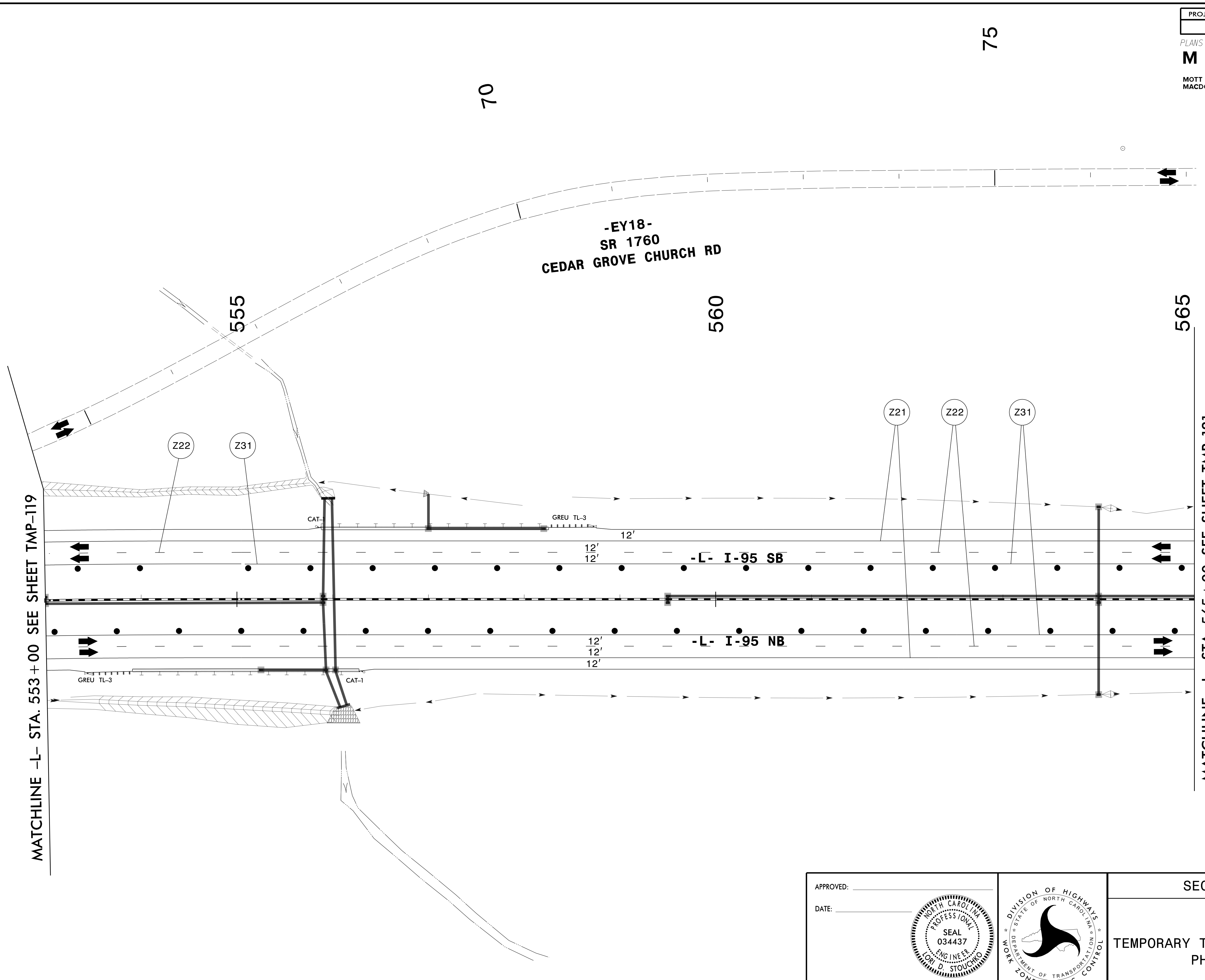
M MOTT MACDONALD I & E, LLC
 1101 HAYNES STREET, SUITE 101
 RALEIGH, NC 27604
M MOTT MACDONALD NC LICENSE NO. F-0669



3/29/2022
 G:\50100191\NV5_L-5987B\TrafficControl\Tep\200_509_L-5987B-TMP-120_Phase V_9.dgn
 User:ST086227

APPROVED: _____ DATE: _____ 		<p align="center">SECTION 1</p> <p align="center">TEMPORARY TRAFFIC CONTROL PHASE V</p>
<p align="center">DOCUMENT NOT CONSIDERED FINAL UNLESS ALL SIGNATURES COMPLETED</p>		

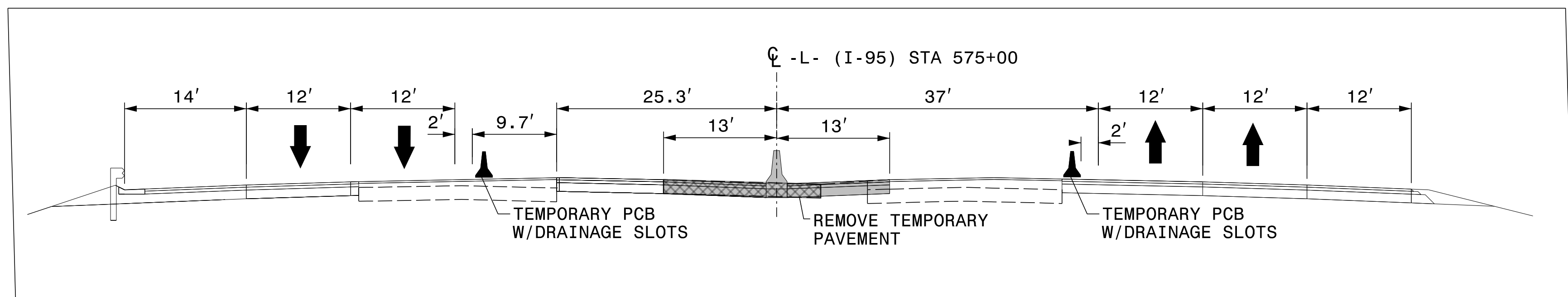
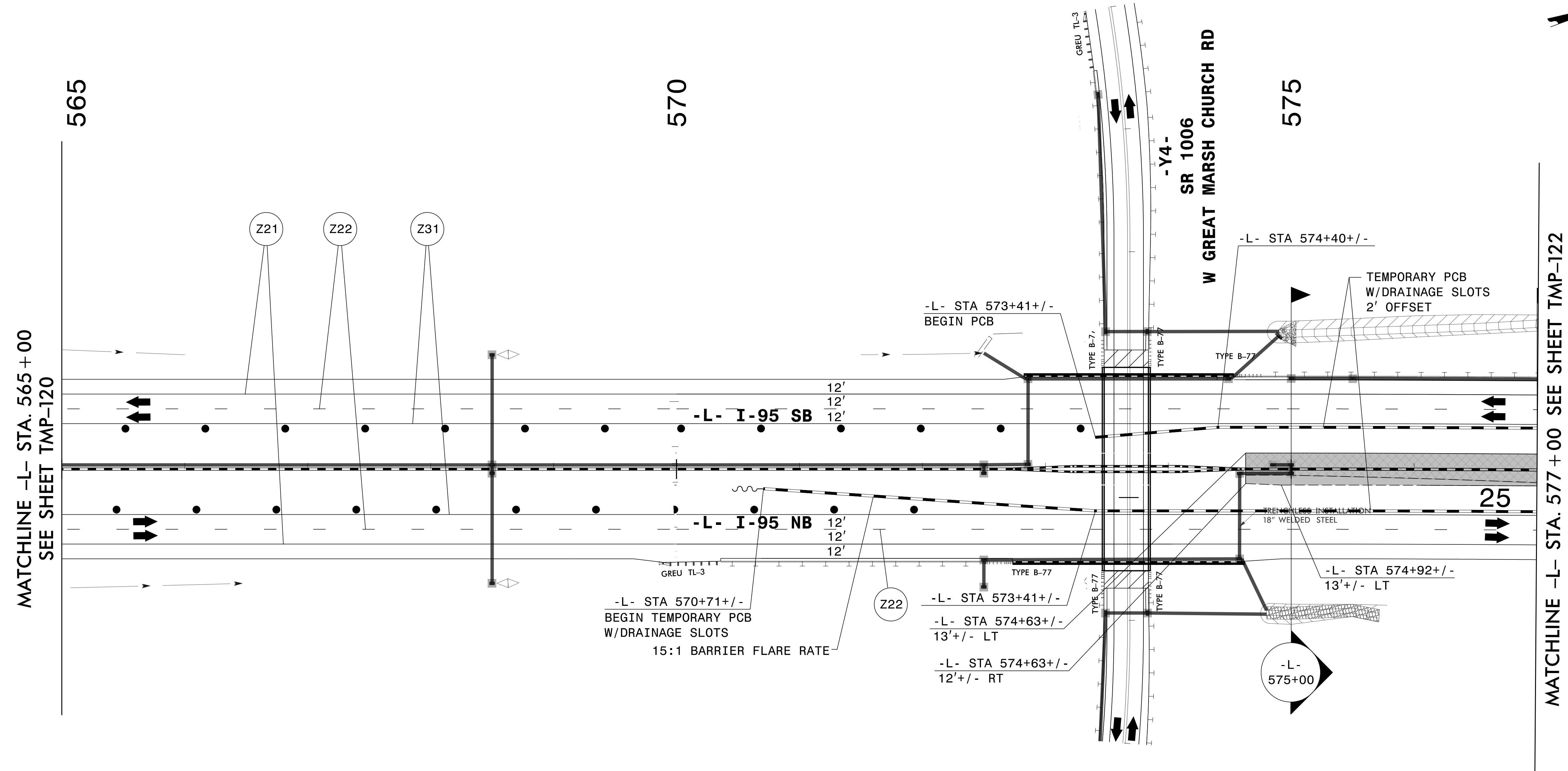
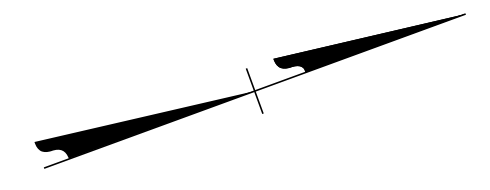

4/29/2022 G:\50100191\NV5_1-5987B\TrafficControl\Top\200_511\I-5987B_TMP-121_Phase V_10.dgn User:ST086227

APPROVED: _____

DATE: _____

**DOCUMENT NOT CONSIDERED FINAL
UNLESS ALL SIGNATURES COMPLETED**

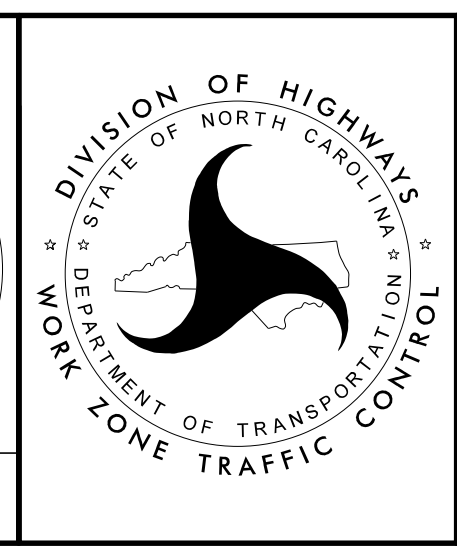

SECTION 1

TEMPORARY TRAFFIC CONTROL
PHASE V

PLANS PREPARED FOR THE NCDOT BY:

M MOTT MACDONALD I & E, LLC
 1101 HAYNES STREET, SUITE 101
 RALEIGH, NC 27604
M MOTT MACDONALD
 NC LICENSE NO. F-0669

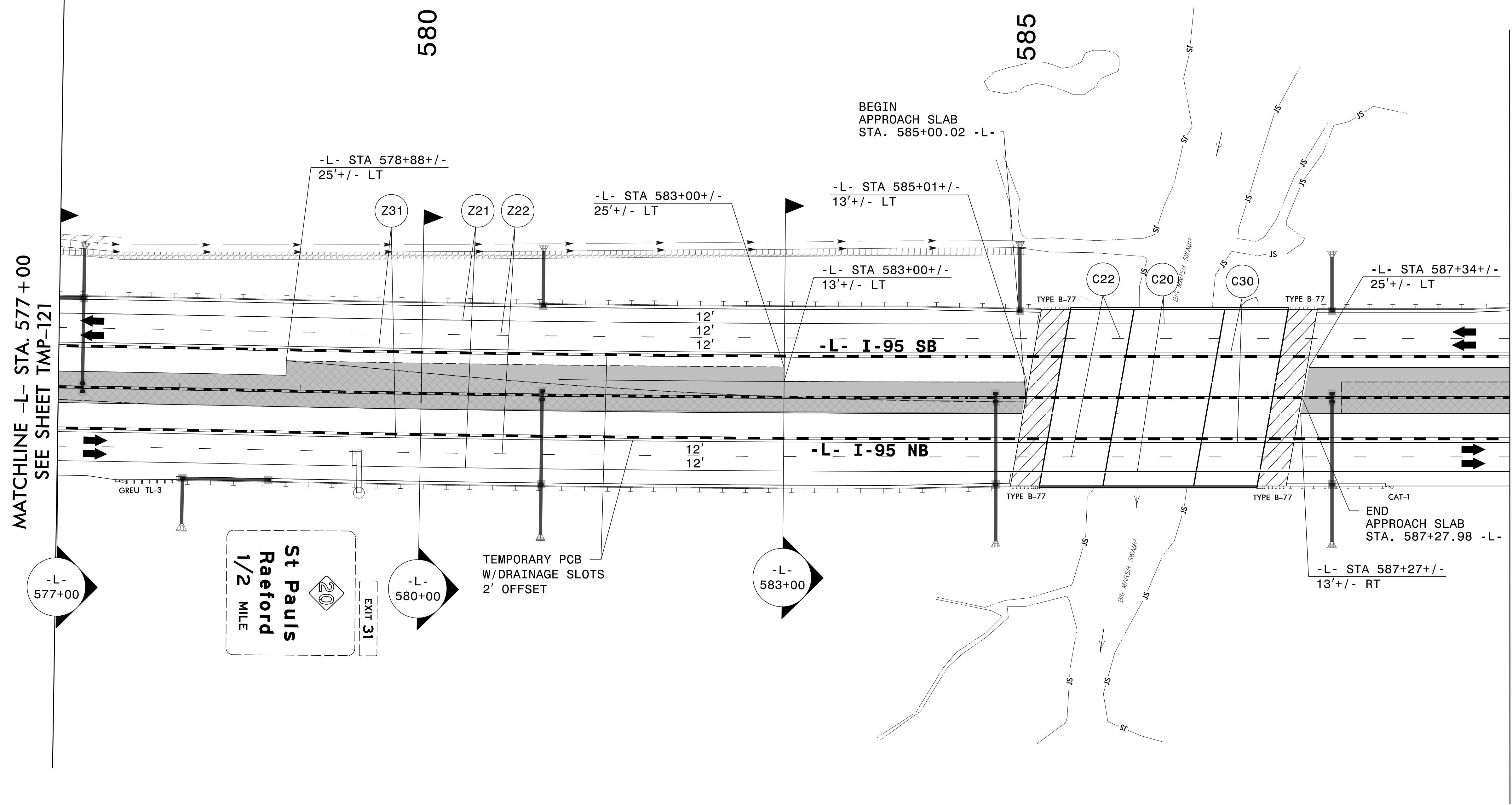
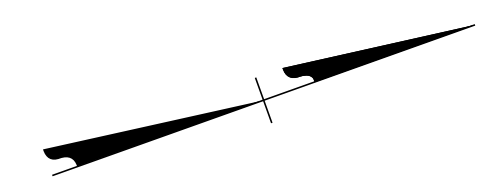

3/29/2022
 G:\50100191\NV5_L-5987B\TrafficControl\Toc\200_513_L-5987B_TMP-122_Phase V_IL.dgn
 User:ST086227

SEE SHEET TMP-123
FOR SECTIONS

APPROVED: _____
 DATE: _____

**DOCUMENT NOT CONSIDERED FINAL
UNLESS ALL SIGNATURES COMPLETED**

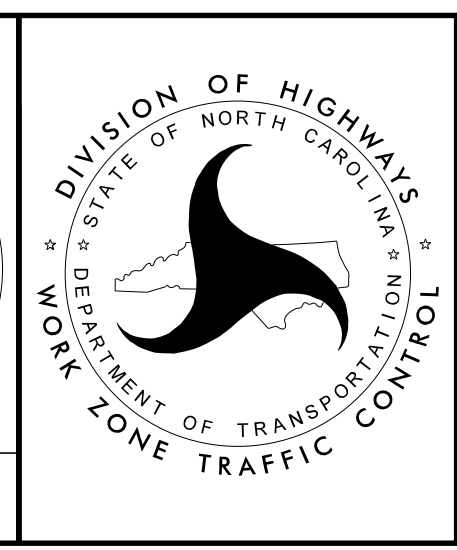

SECTION 1

**TEMPORARY TRAFFIC CONTROL
PHASE V**

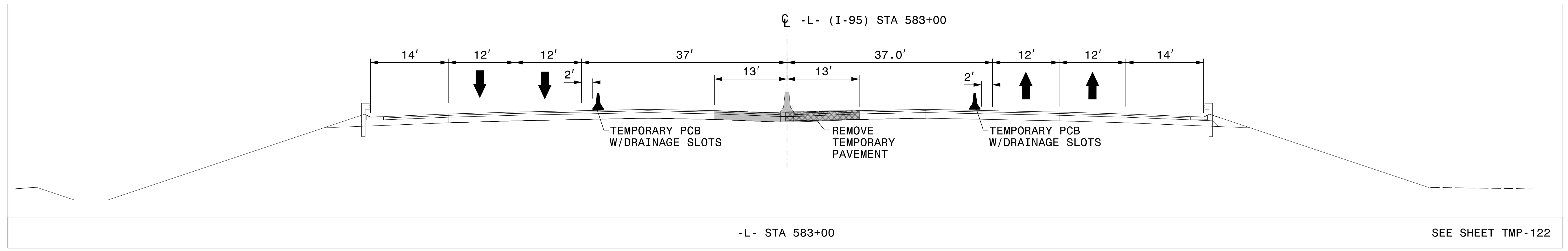
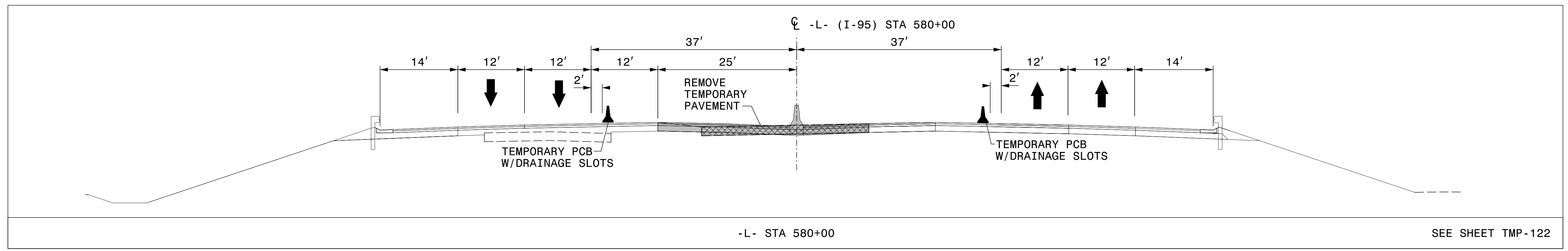
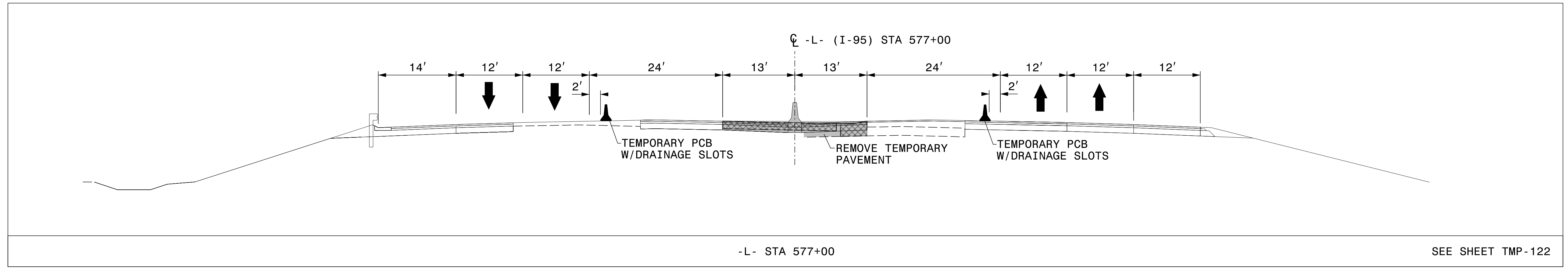

3/29/2022
 G:\50100191\NV5_I-5987B\TrafficControl\Twp\200_515_I-5987B_TMP-123_Phase V_IL.dgn
 User:ST086227

APPROVED: _____			SECTION 1
DATE: _____			TEMPORARY TRAFFIC CONTROL PHASE V
<p>DOCUMENT NOT CONSIDERED FINAL UNLESS ALL SIGNATURES COMPLETED</p>			

PROJ. REFERENCE NO.	SHEET NO.
I-5987B	TMP-124

PLANS PREPARED FOR THE NCDOT BY:
M MOTT MACDONALD I & E, LLC
 1101 HAYNES STREET, SUITE 101
 RALEIGH, NC 27604
M MOTT MACDONALD
 NC LICENSE NO. F-0669

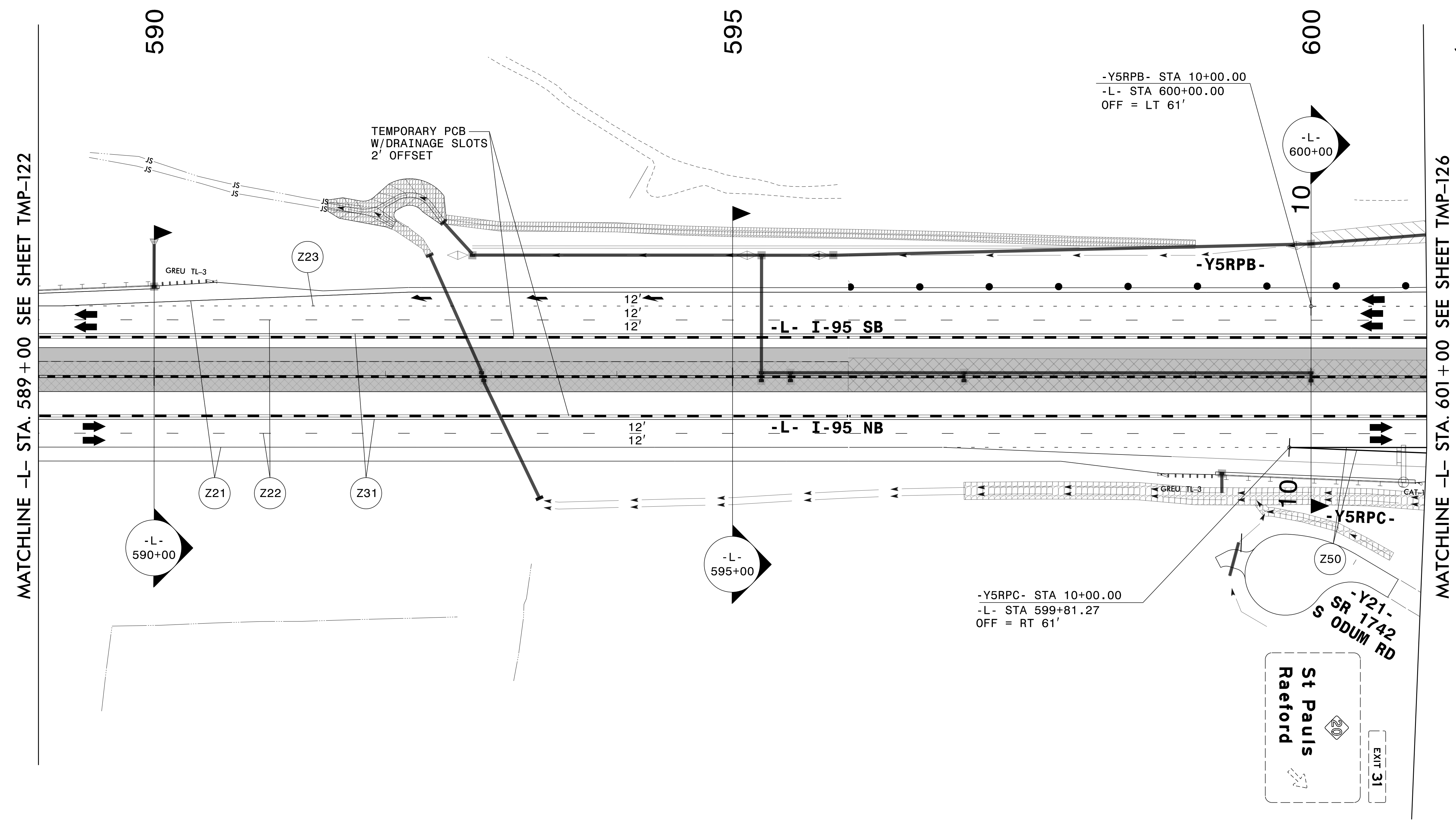

MATCHLINE -L- STA. 589 + 00 SEE SHEET TMP-122

MATCHLINE -L- STA. 601 + 00 SEE SHEET TMP-126

SEE SHEET TMP-125 FOR SECTIONS

3/29/2022 G:\50100191\NV5_I-5987B\TrafficControl\Tcpl\200_517_I-5987B_TMP-124_Phase V_I2.dgn User:ST086227

APPROVED: _____ DATE: _____			SECTION 1
<p>DOCUMENT NOT CONSIDERED FINAL UNLESS ALL SIGNATURES COMPLETED</p>			<p>TEMPORARY TRAFFIC CONTROL PHASE V</p>

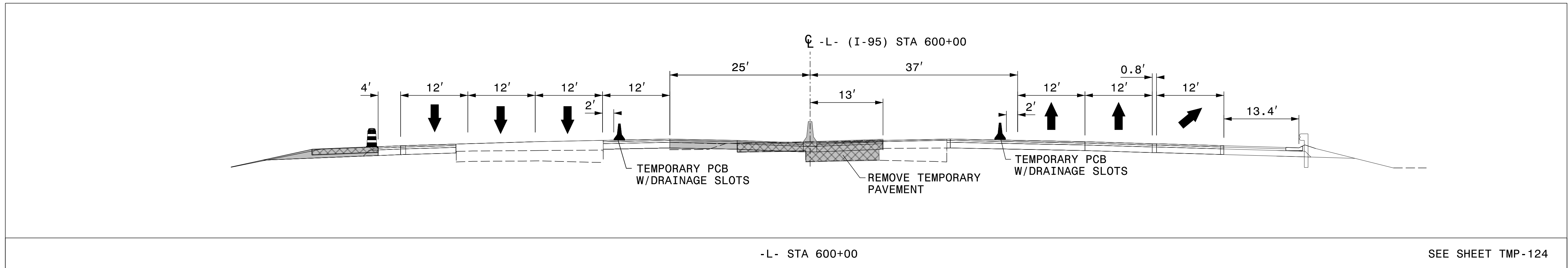
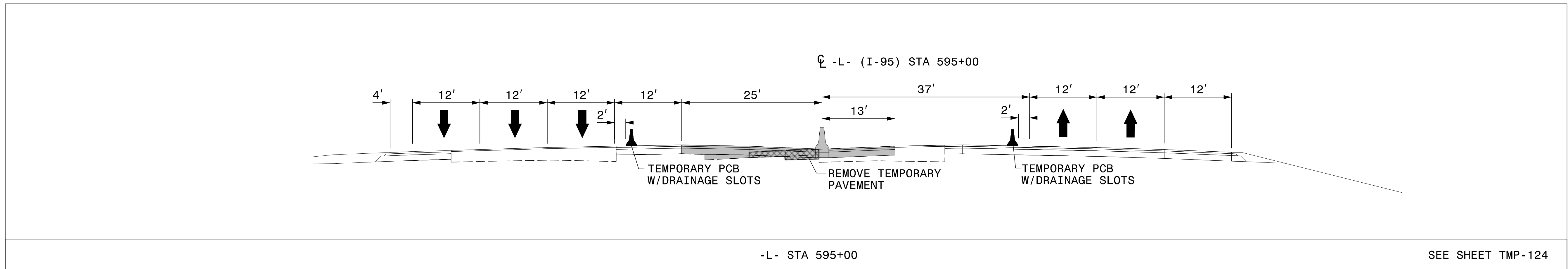
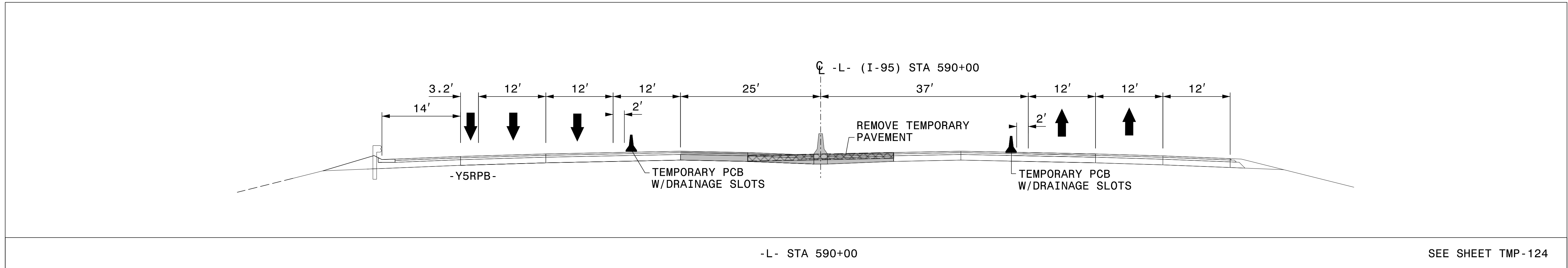

3/29/2022
 G:\50100191\NV5_I-5987B\TrafficControl\Tcpl\200_519_I-5987B_TMP-125_Phase_V_L2.dgn
 User:ST086227

APPROVED: _____
 DATE: _____

**DOCUMENT NOT CONSIDERED FINAL
 UNLESS ALL SIGNATURES COMPLETED**



SECTION 1

**TEMPORARY TRAFFIC CONTROL
 PHASE V**

PLANS PREPARED FOR THE NCDOT BY:

M MOTT MACDONALD I & E, LLC
 1101 HAYNES STREET, SUITE 101
 RALEIGH, NC 27604
M MOTT MACDONALD
 NC LICENSE NO. F-0669

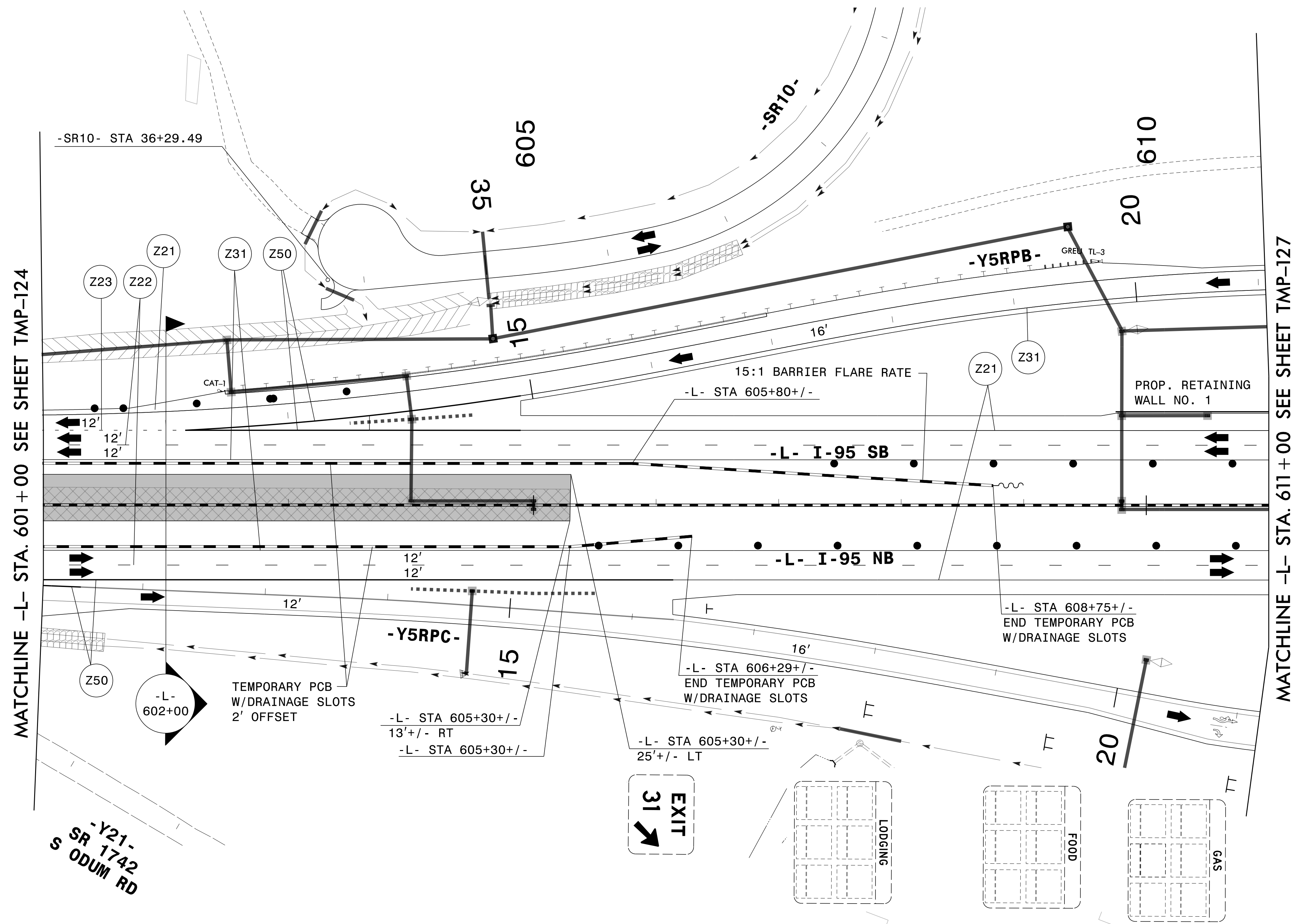
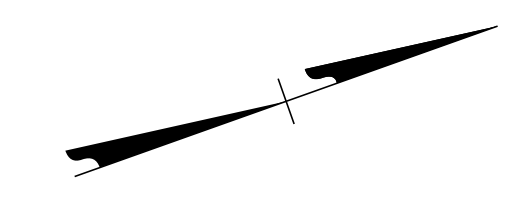

MATCHLINE -L- STA. 601 + 00 SEE SHEET TMP-124

MATCHLINE -L- STA. 611 + 00 SEE SHEET TMP-127

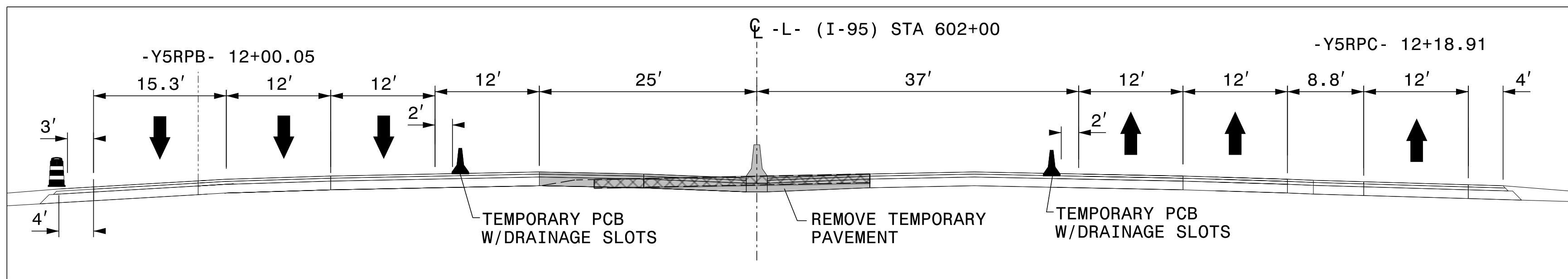

3/29/2022
 G:\50100191\NV5_I-5987B\TrafficControl\Top\200_521-I-5987B_TMP-126_Phase_V_13.dgn
 User:ST086227

APPROVED: _____
 DATE: _____

**DOCUMENT NOT CONSIDERED FINAL
 UNLESS ALL SIGNATURES COMPLETED**

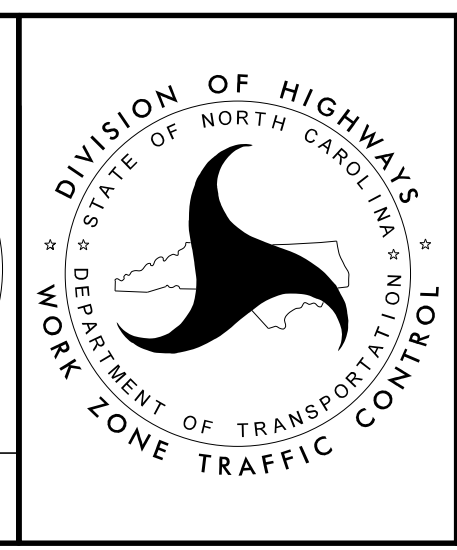

SECTION 1

**TEMPORARY TRAFFIC CONTROL
 PHASE V**

PLANS PREPARED FOR THE NCDOT BY:

M MOTT MACDONALD I & E, LLC
 1101 HAYNES STREET, SUITE 101
 RALEIGH, NC 27604
 NC LICENSE NO. F-0669

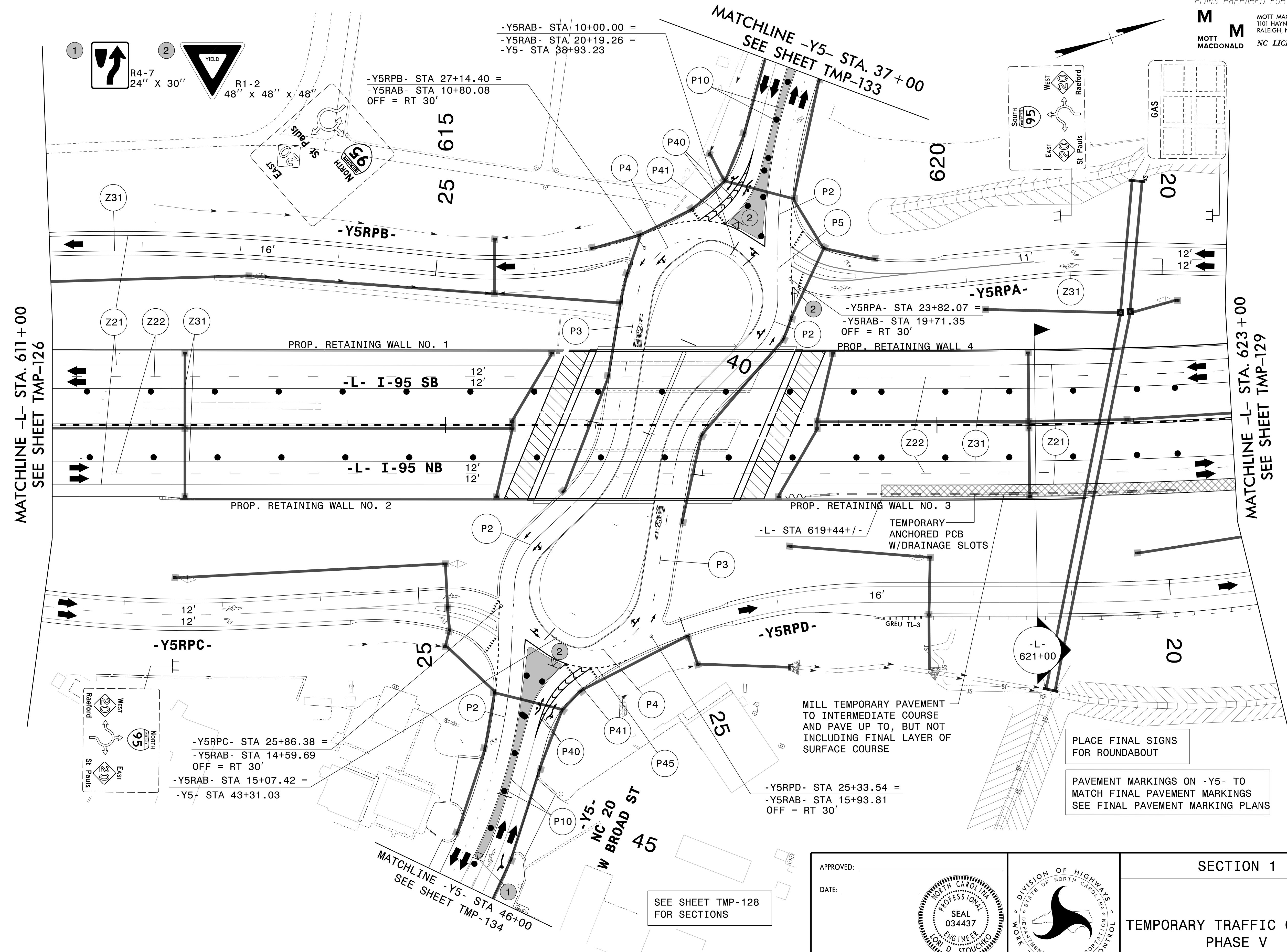

MATCHLINE -L- STA. 611+00
SEE SHEET TMP-126

MATCHLINE -L- STA. 623+00
SEE SHEET TMP-129

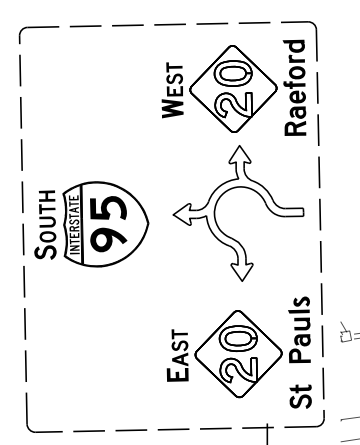
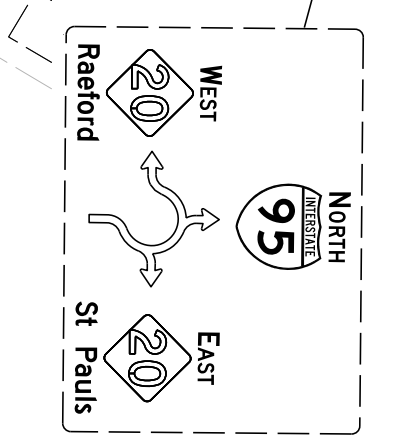
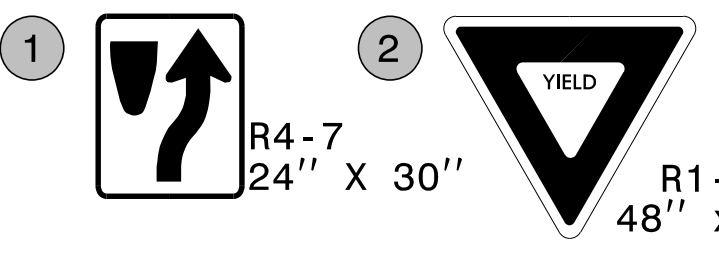

APPROVED: _____
 DATE: _____

SEAL
 034437
 ENGINEER
 LORI D. STOUCHE

**DOCUMENT NOT CONSIDERED FINAL
 UNLESS ALL SIGNATURES COMPLETED**

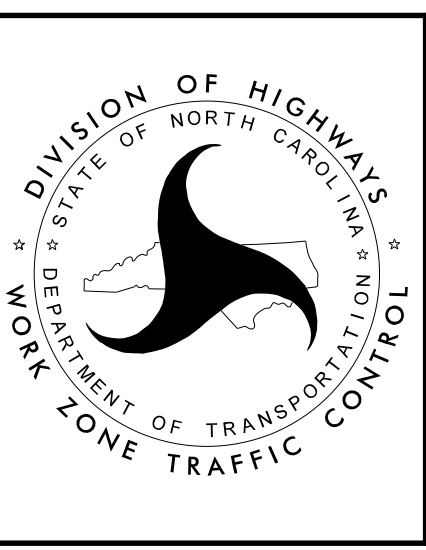

SECTION 1

**TEMPORARY TRAFFIC CONTROL
 PHASE V**

SEE SHEET TMP-128
FOR SECTIONS

MILL TEMPORARY PAVEMENT TO INTERMEDIATE COURSE AND PAVE UP TO, BUT NOT INCLUDING FINAL LAYER OF SURFACE COURSE

PLACE FINAL SIGNS FOR ROUNDABOUT

PAVEMENT MARKINGS ON -Y5- TO MATCH FINAL PAVEMENT MARKINGS
SEE FINAL PAVEMENT MARKING PLANS

3/29/2022
 G:\50100191\NV5_1-5987B\TrafficControl\Twp\200_523_1-5987B-TMP-127_Phase V_14.dgn
 User:ST086227

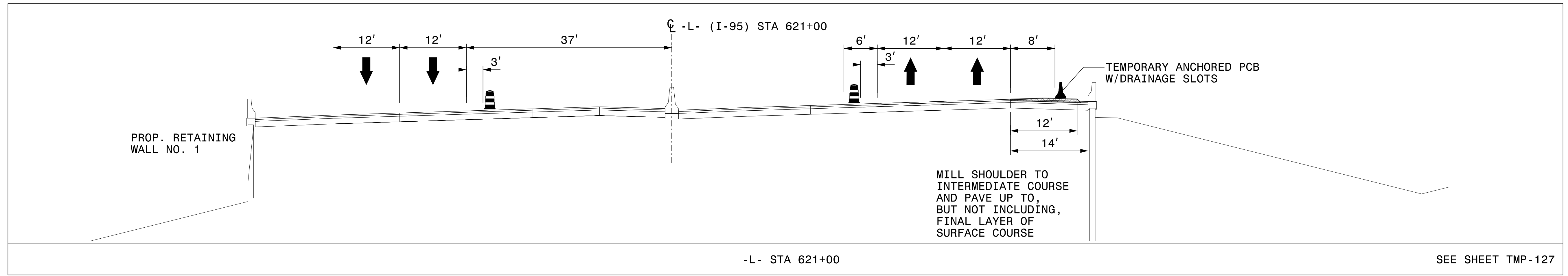

SEE SHEET TMP-127

3/29/2022
 G:\50100191\NV5_I-5987B\TrafficControl\Top\200_525_I-5987B_TMP-128_Phase V_1.dgn
 User:ST086227

APPROVED: _____			SECTION 1
DATE: _____			TEMPORARY TRAFFIC CONTROL PHASE V
<p>DOCUMENT NOT CONSIDERED FINAL UNLESS ALL SIGNATURES COMPLETED</p>			

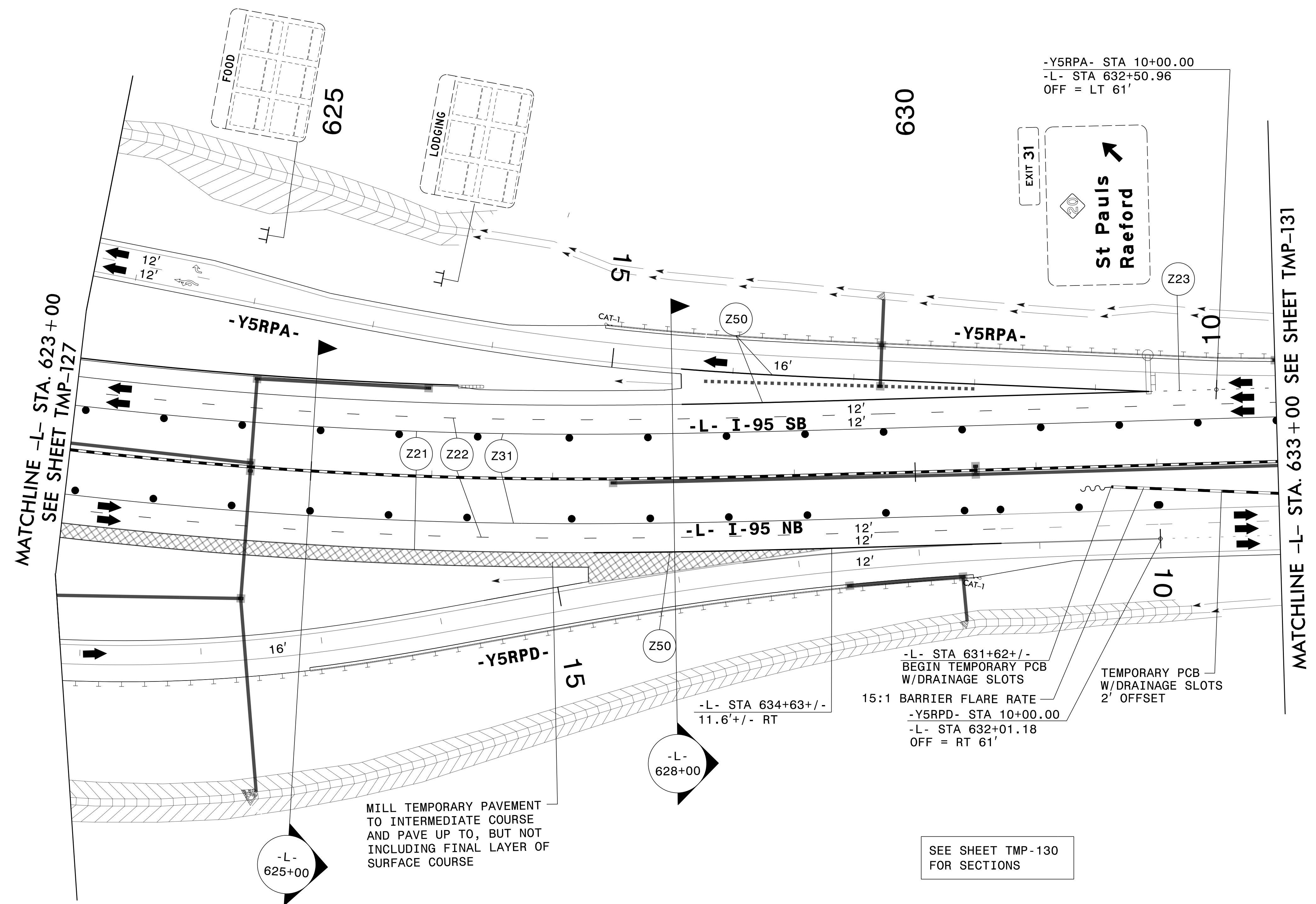
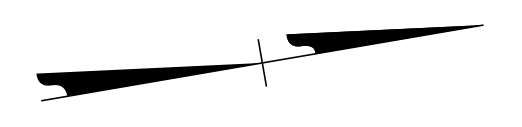

SEE SHEET TMP-130 FOR SECTIONS

APPROVED: _____

DATE: _____

DOCUMENT NOT CONSIDERED FINAL UNLESS ALL SIGNATURES COMPLETED

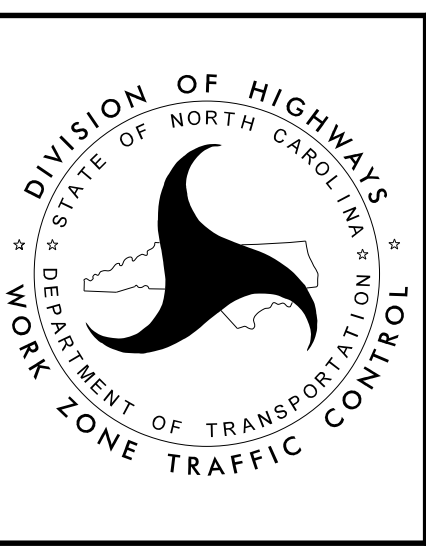

SECTION 1

TEMPORARY TRAFFIC CONTROL PHASE V

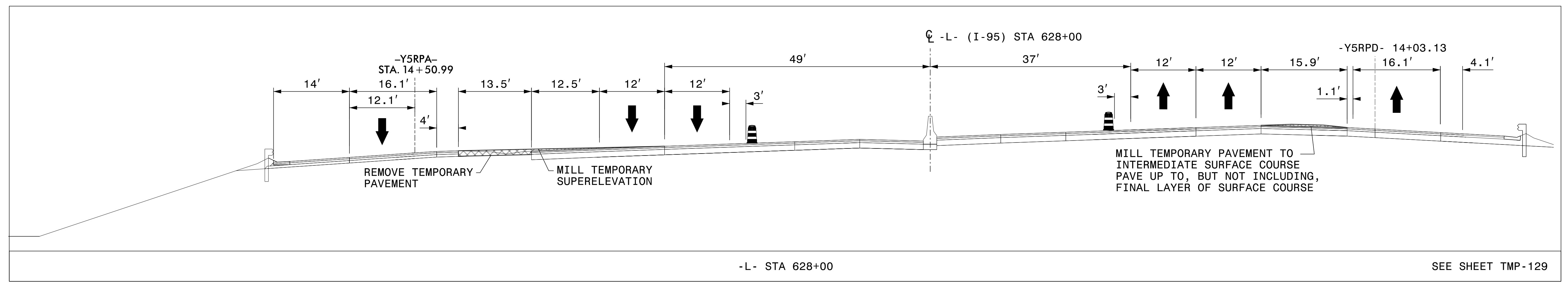
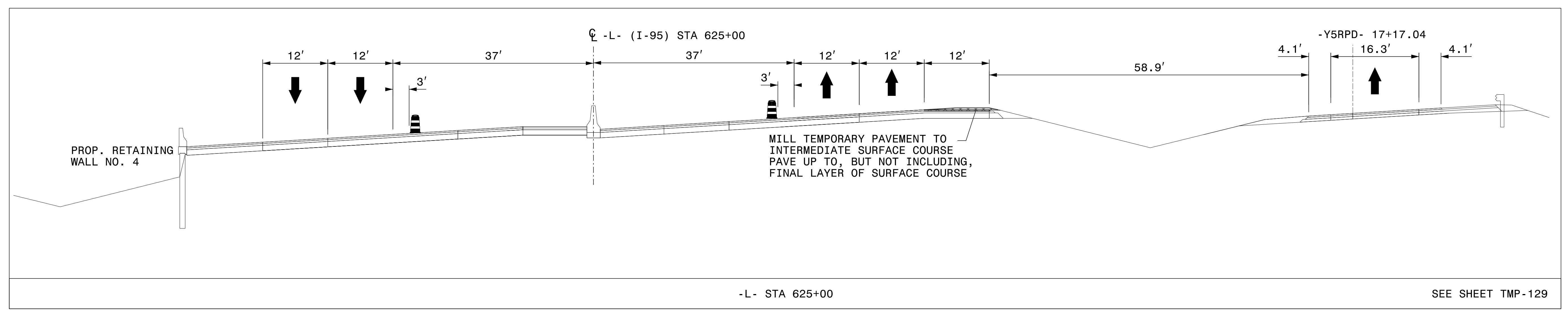

3/29/2022 G:\50100191\NV5_I-5987B\TrafficControl\Twp\200_529_I-5987B-TMP-130_Phase V.dgn User:ST086227

APPROVED: _____			SECTION 1
DATE: _____			TEMPORARY TRAFFIC CONTROL PHASE V
<p>DOCUMENT NOT CONSIDERED FINAL UNLESS ALL SIGNATURES COMPLETED</p>			

PROJ. REFERENCE NO.	SHEET NO.
I-5987B	TMP-131

PLANS PREPARED FOR THE NCDOT BY:

M MOTT MACDONALD I & E, LLC
 1101 HAYNES STREET, SUITE 101
 RALEIGH, NC 27604
M MOTT MACDONALD NC LICENSE NO. F-0669

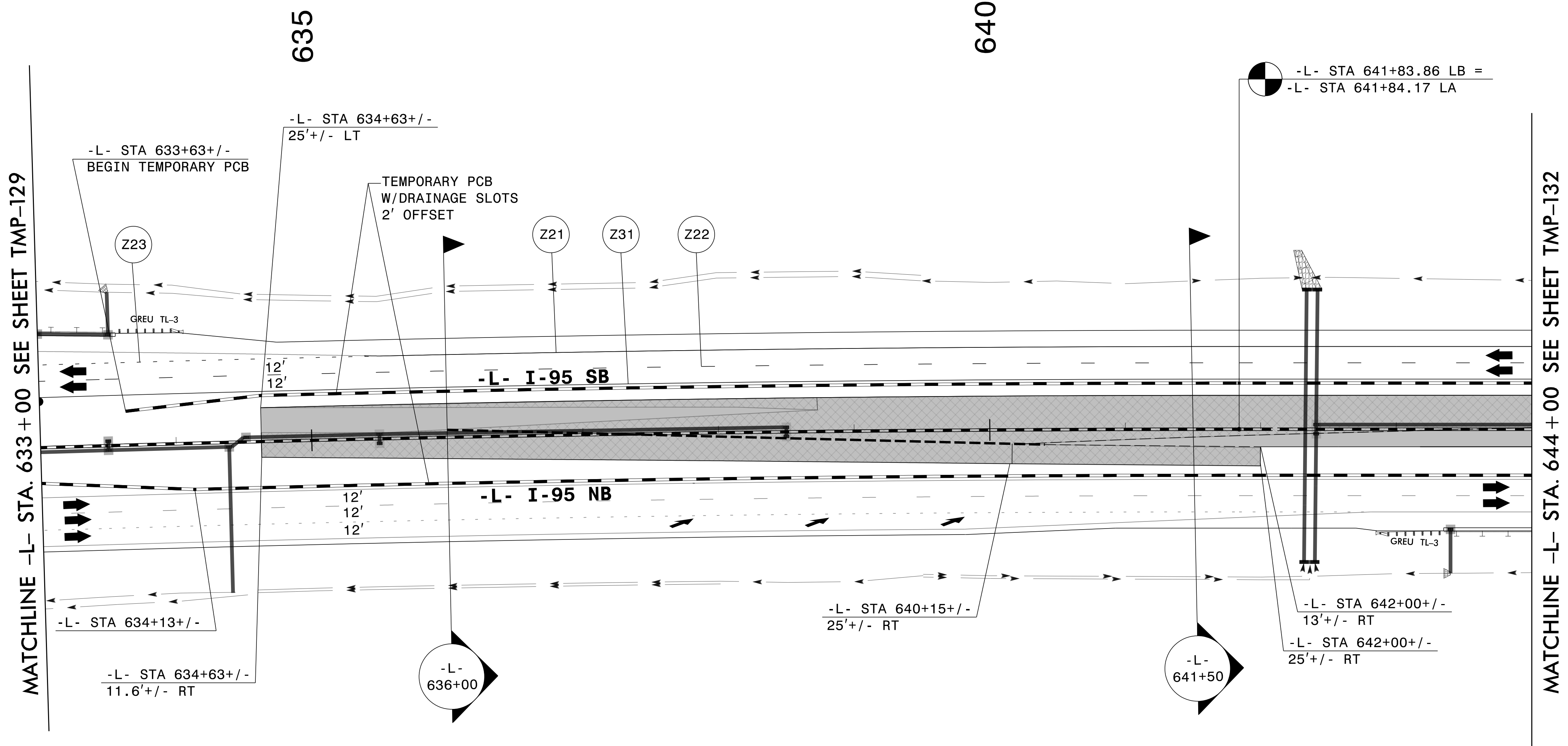

SEE SHEET TMP-131
FOR SECTIONS

3/29/2022
 G:\50100191\NV5_L-5987B\TrafficControl\Top\200_531_L-5987B_TMP-131_Phase V_16.dgn
 User:ST086227

APPROVED: _____			SECTION 1
DATE: _____			TEMPORARY TRAFFIC CONTROL PHASE V
<p>DOCUMENT NOT CONSIDERED FINAL UNLESS ALL SIGNATURES COMPLETED</p>			

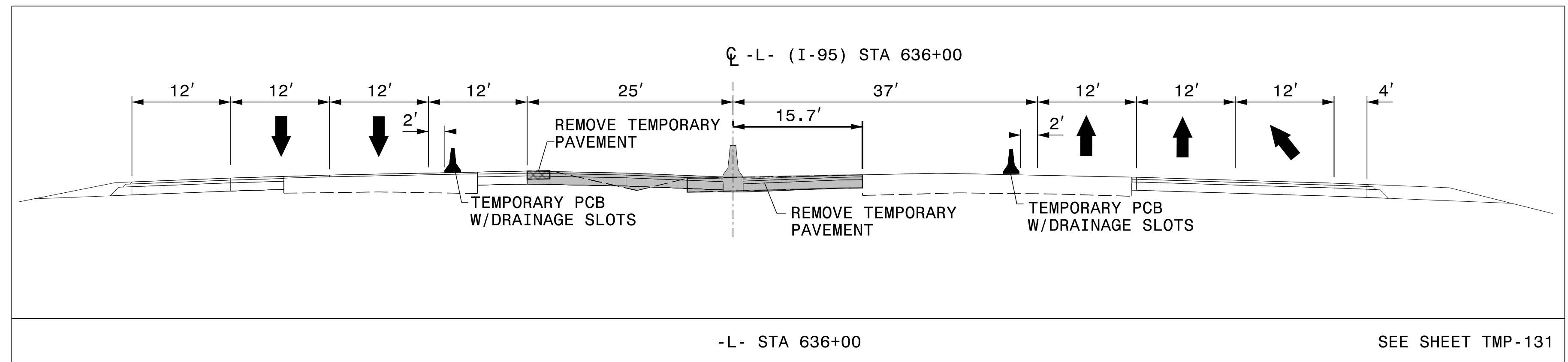

-L- STA 636+00 SEE SHEET TMP-131

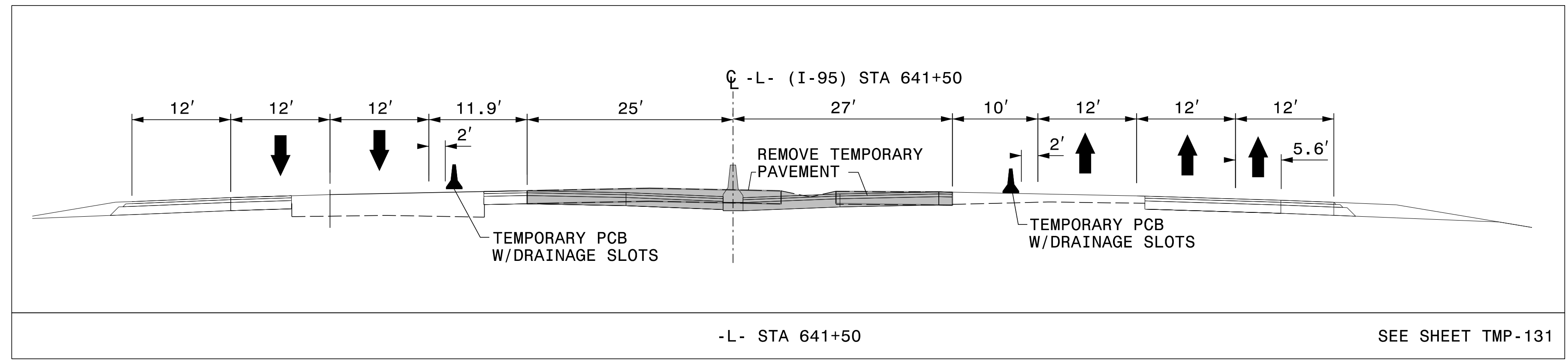

-L- STA 641+50 SEE SHEET TMP-131

3/29/2022 G:\50100191\NV5_1-5987B\TrafficControl\Top\200_533_1-5987B-TMP-131A_Phase V.dgn User:ST086227

APPROVED: _____
 DATE: _____

SEAL
 034437
 ENGINEER
 LORI D. STOUCHE

**DOCUMENT NOT CONSIDERED FINAL
 UNLESS ALL SIGNATURES COMPLETED**

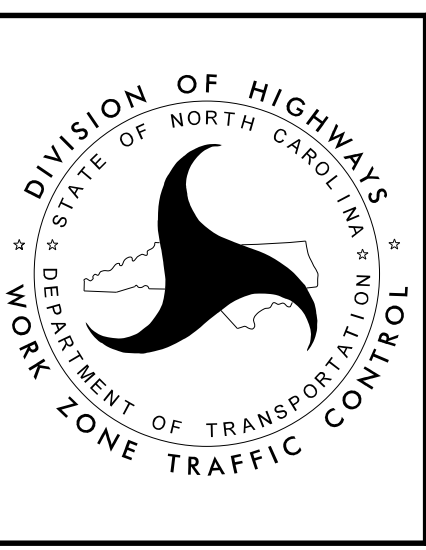

SECTION 1

**TEMPORARY TRAFFIC CONTROL
 PHASE V**

PROJ. REFERENCE NO.	SHEET NO.
I-5987B	TMP-132

PLANS PREPARED FOR THE NCDOT BY:

M MOTT MACDONALD I & E, LLC
 1101 HAYNES STREET, SUITE 101
 RALEIGH, NC 27604
M MOTT MACDONALD NC LICENSE NO. F-0669

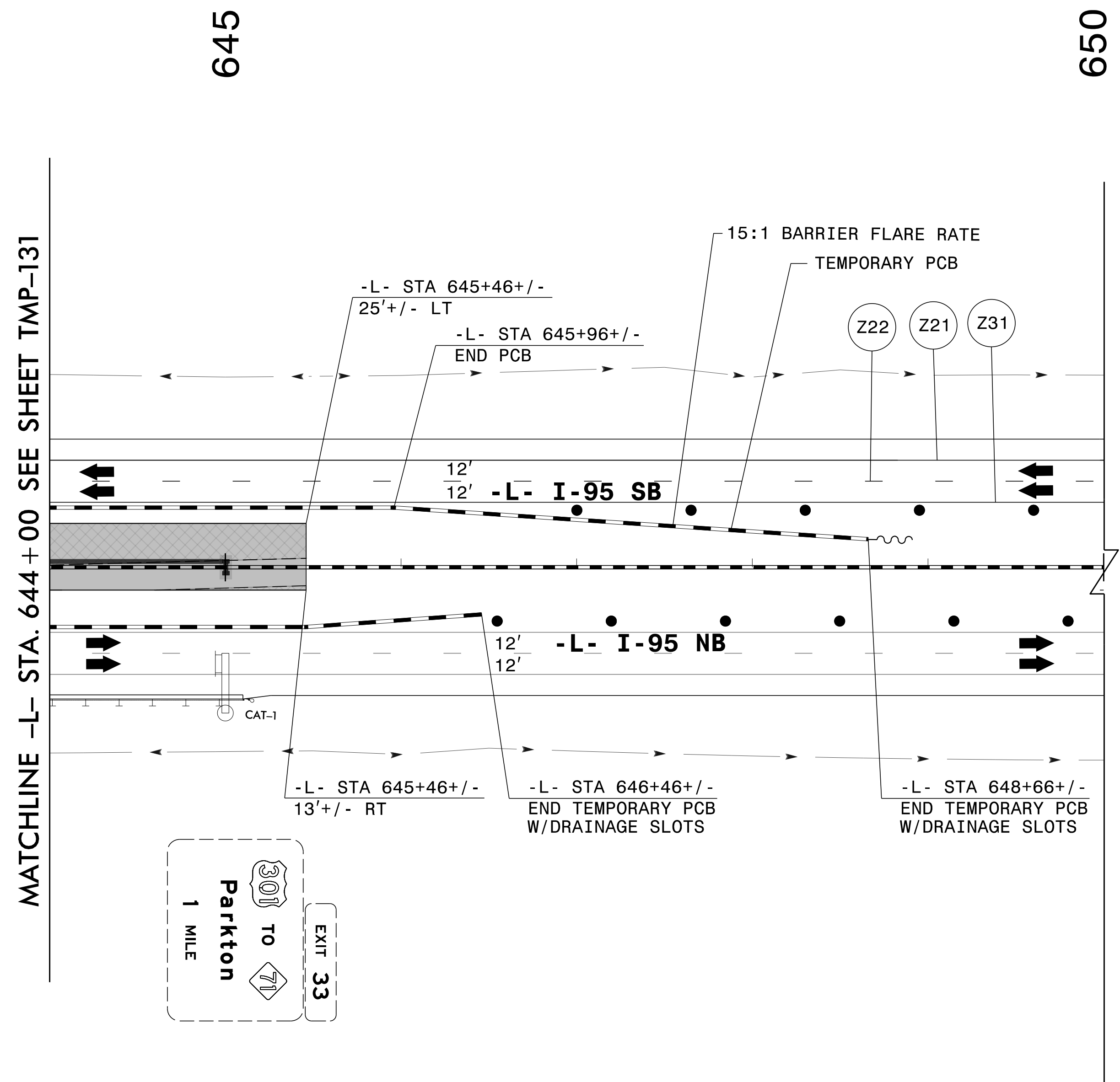
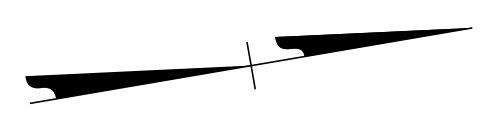

3/29/2022
 G:\50100191\NV5_I-5987B\TrafficControl\Tep\200_535_I-5987B_TMP-132_Phase V.dgn
 User:ST086227

APPROVED: _____
 DATE: _____

**DOCUMENT NOT CONSIDERED FINAL
 UNLESS ALL SIGNATURES COMPLETED**

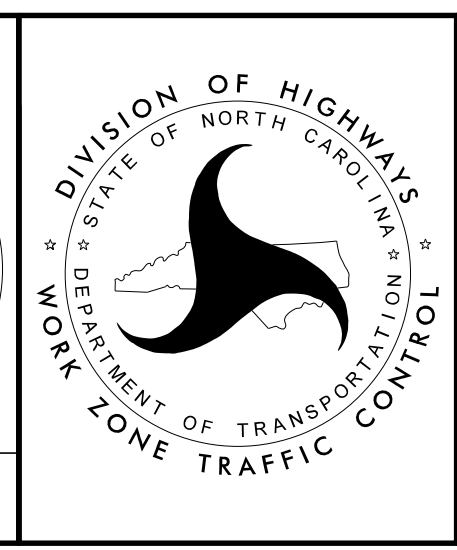

SECTION 1

**TEMPORARY TRAFFIC CONTROL
 PHASE V**

PROJ. REFERENCE NO.	SHEET NO.
I-5987B	TMP-133

PLANS PREPARED FOR THE NCDOT BY:

M MOTT MACDONALD I & E, LLC
 1101 HAYNES STREET, SUITE 101
 RALEIGH, NC 27604
M MOTT MACDONALD NC LICENSE NO. F-0669

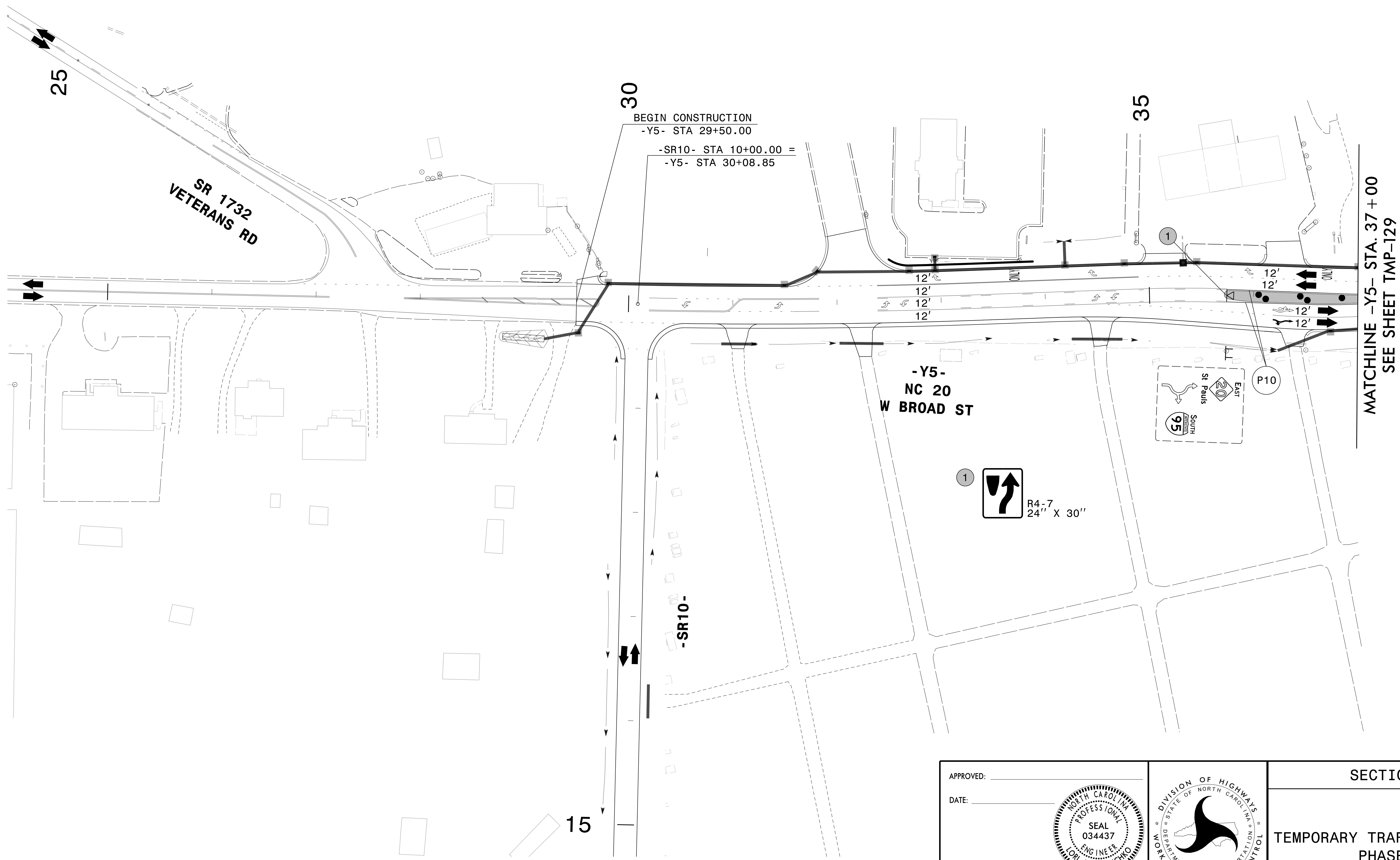
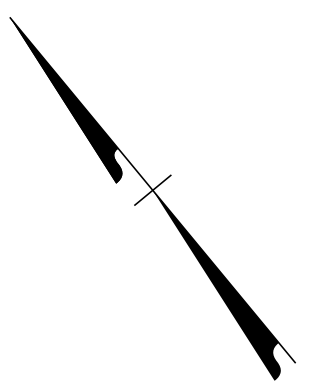

3/29/2022
 G:\50100191\NV5_I-5987B\TrafficControl\Top\200_537_I-5987B_TMP-133_Phase V_Y5.dgn
 User:ST086227

APPROVED: _____
 DATE: _____

**DOCUMENT NOT CONSIDERED FINAL
 UNLESS ALL SIGNATURES COMPLETED**



SECTION 1

TEMPORARY TRAFFIC CONTROL
 PHASE V

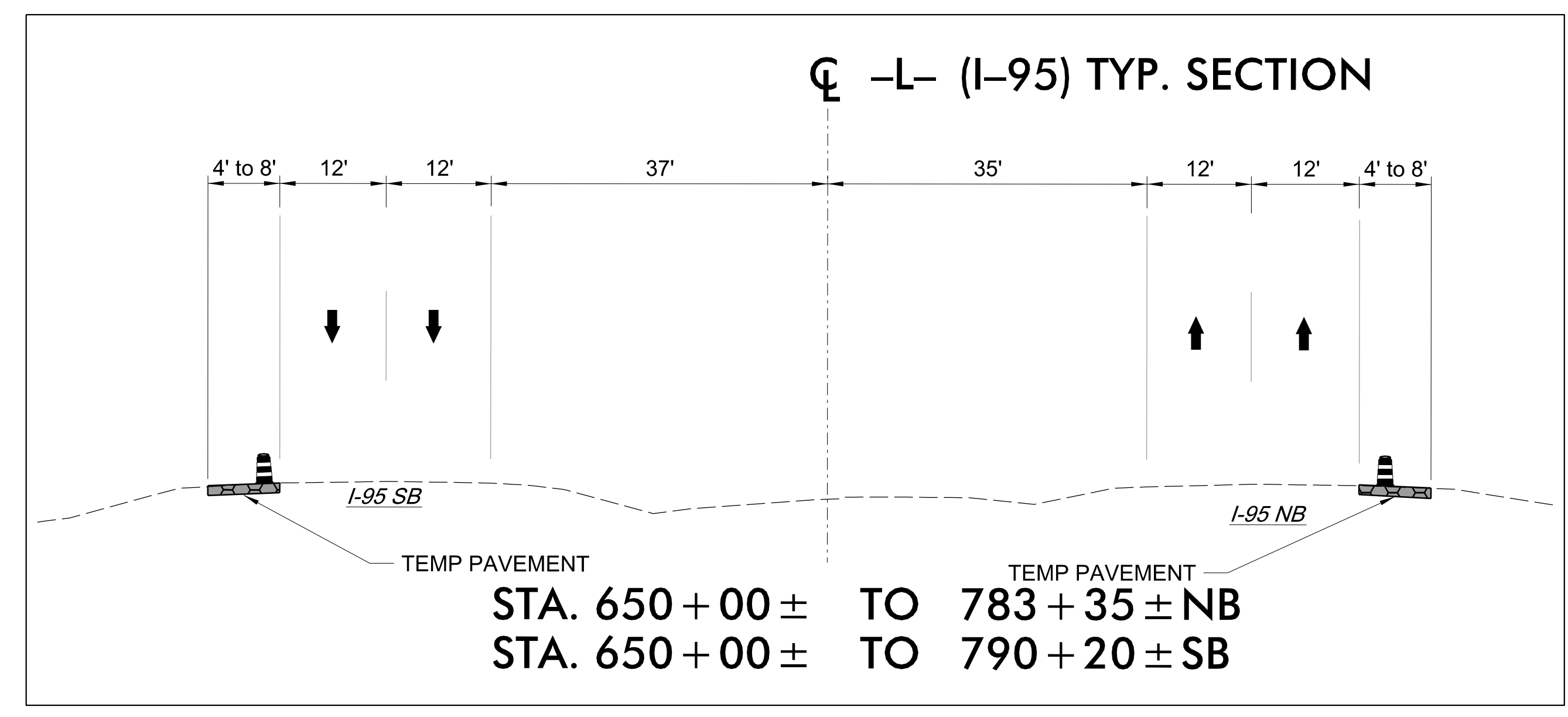
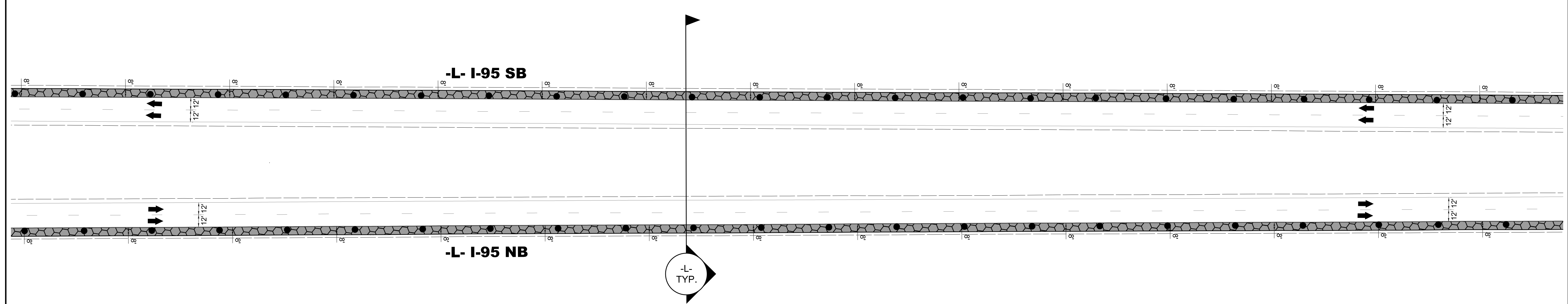

3/15/2022
 U:\Traffic\Transportation Management Plan\TCP\PLAN SHEETS\I-5987B_TMP_134_PHASE_1_STEP_1A.dgn
 angood

Stantec
 Stantec Consulting Services Inc.
 801 Jones Franklin Road
 Suite 300
 Raleigh, NC 27606
 Tel. 919.851.6866
 Fax. 919.851.7024
 www.stantec.com
 License No. F-0672

DocuSigned by:
 J.W. Woollard
 58BC02F49E565C

4/29/2022

**DOCUMENT NOT CONSIDERED FINAL
 UNLESS ALL SIGNATURES COMPLETED**

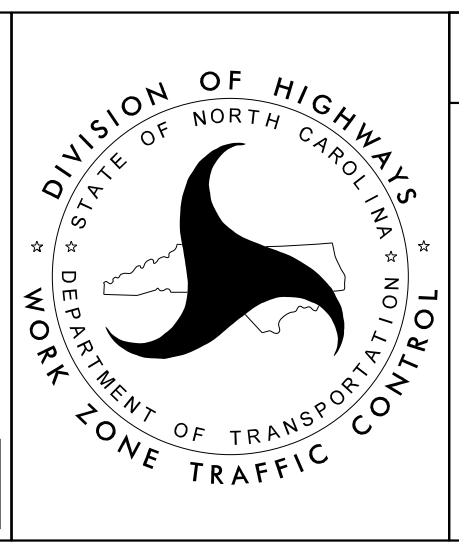

SECTION 2

-L- I-95
 PHASE I
 STEP 1A
 TYPICAL

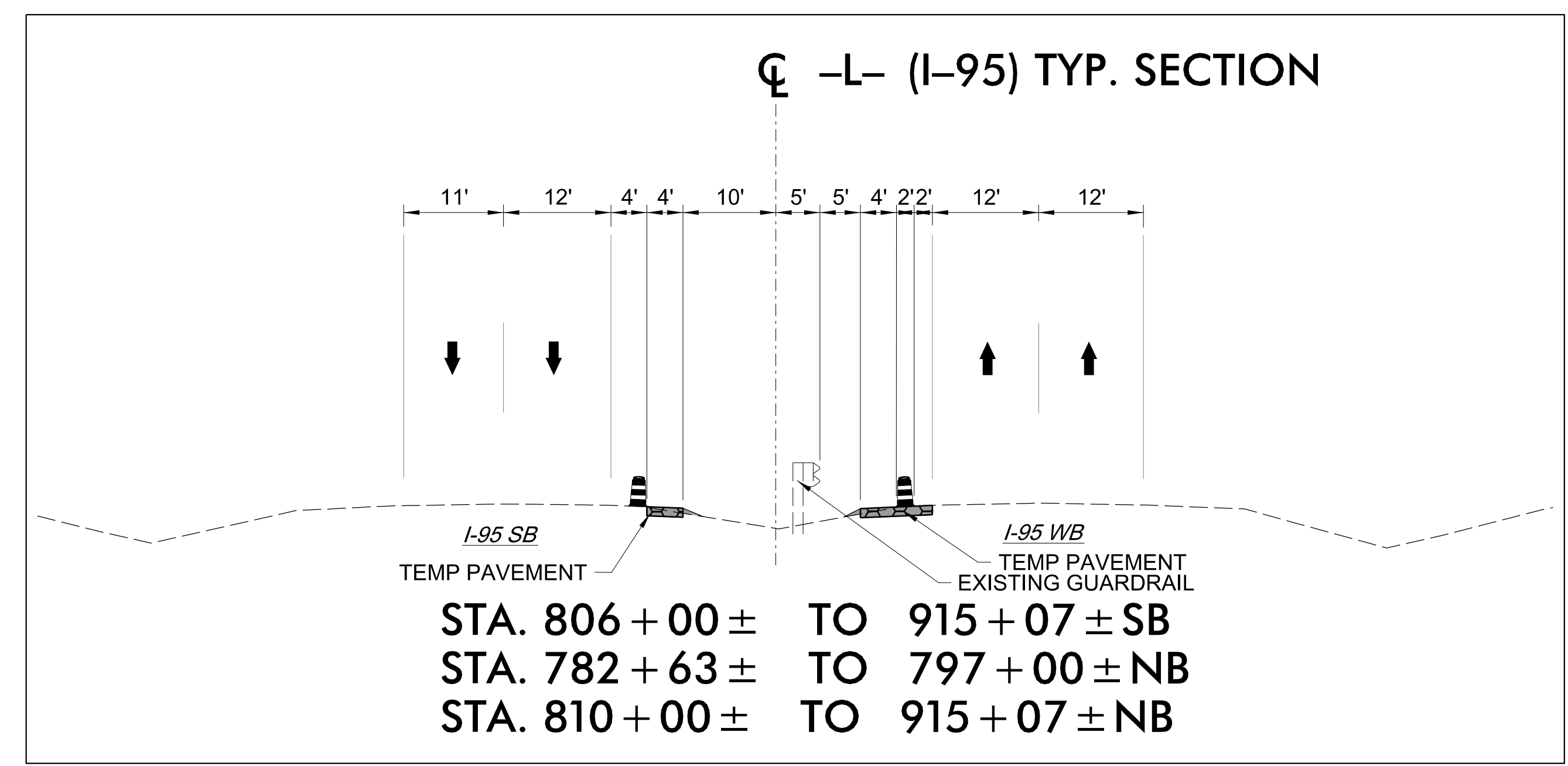
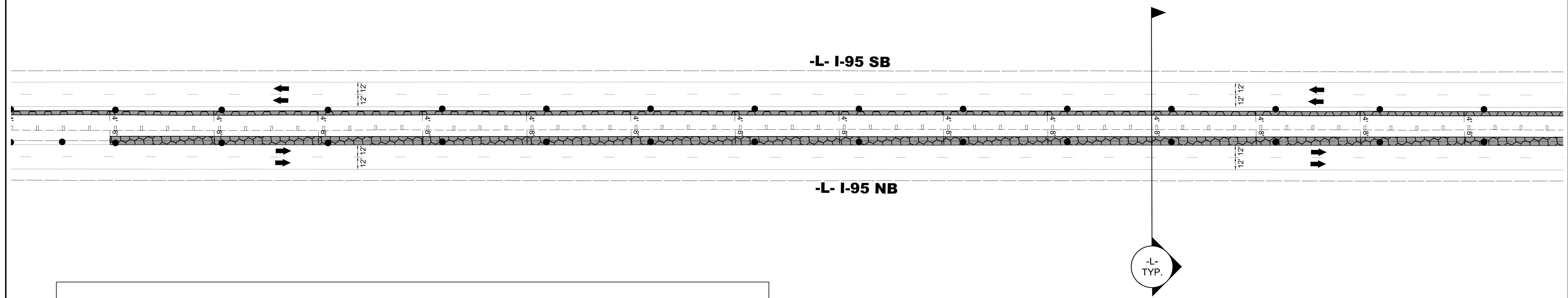

3/15/2022
U:\Traffic\Transportation Management Plan\TCP\PLAN SHEETS\I-5987B_TMP-134A_PHASE I_STEP 1A.dgn
angood

Stantec Consulting Services Inc.
801 Jones Franklin Road
Suite 300
Raleigh, NC 27606
Tel. 919.851.6866
Fax. 919.851.7024
www.stantec.com
License No. F-0672

DocuSigned by
J.W. Woolard
SEAL
19862
ENGINEER
J.W. WOOLARD, JR.

4/29/2022

**DOCUMENT NOT CONSIDERED FINAL
UNLESS ALL SIGNATURES COMPLETED**

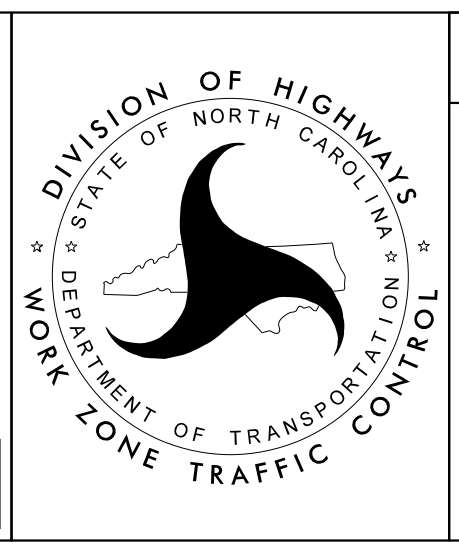

SECTION 2

**-L- I-95
PHASE I
STEP 1A
TYPICAL**

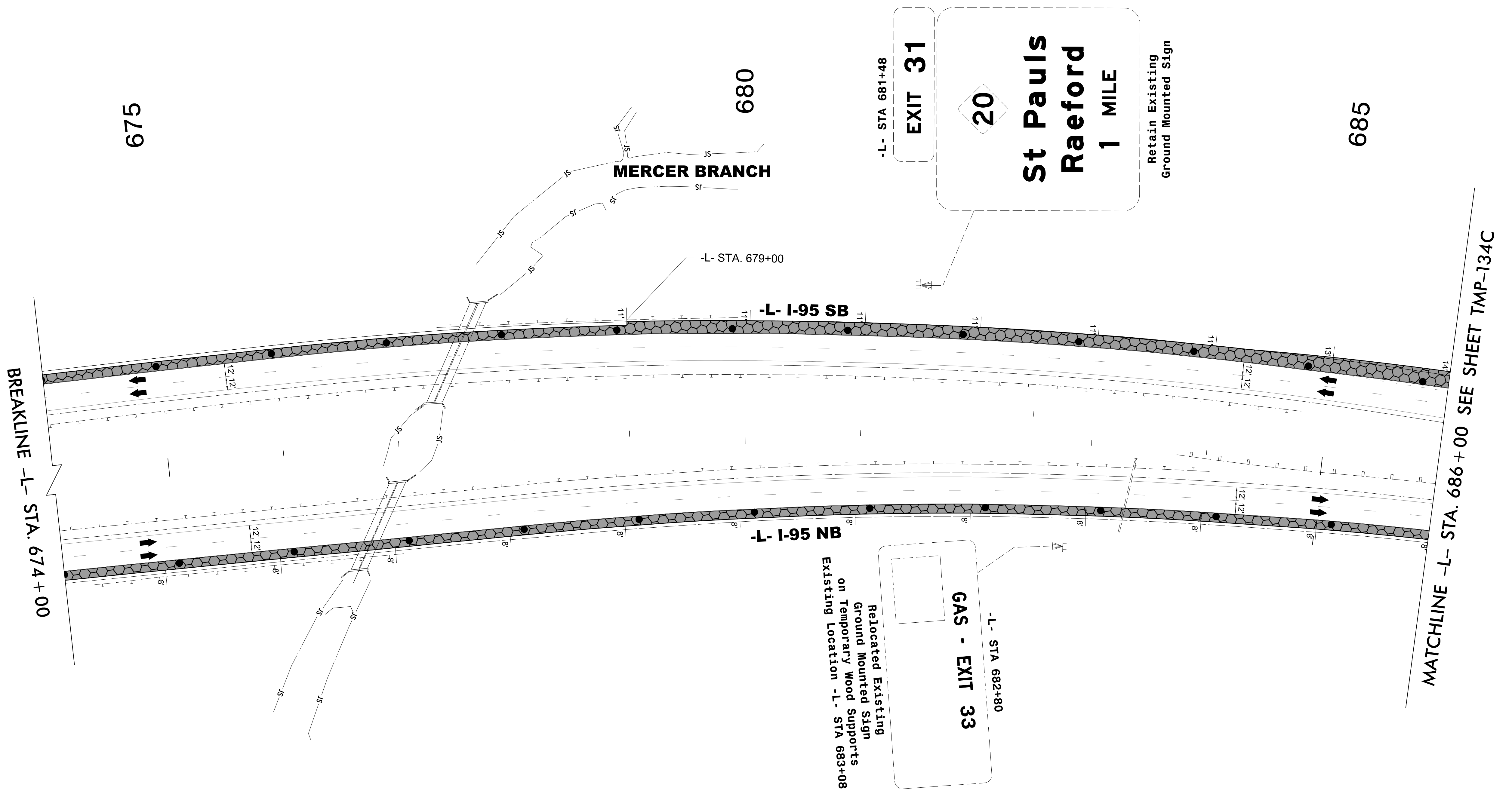
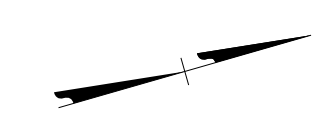

3/15/2022
U:\Traffic\Transportation Management\Plan\TCP\PLAN SHEETS\I-5987B_TMP-134B_PHASE 1_STEP 1A.dgn
angood

Stantec
Stantec Consulting Services Inc.
801 Jones Franklin Road
Suite 300
Raleigh, NC 27606
Tel. 919.851.6866
Fax. 919.851.7024
www.stantec.com
License No. F-0672

DocuSigned by
J.W. Woolard
SEAL
19862
ENGINEER
J.W. WOOLARD, P.E.

4/29/2022

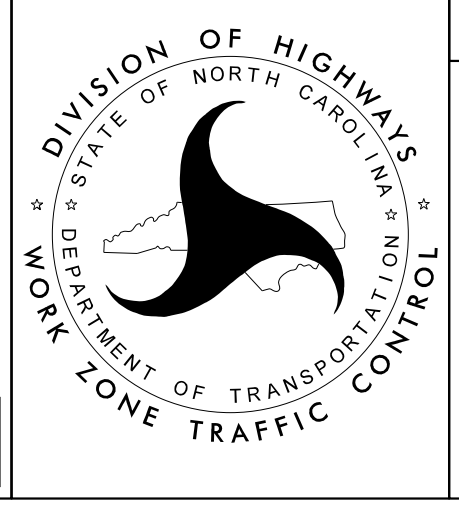

SECTION 2

**-L- I-95
PHASE I
STEP 1A**

**DOCUMENT NOT CONSIDERED FINAL
UNLESS ALL SIGNATURES COMPLETED**

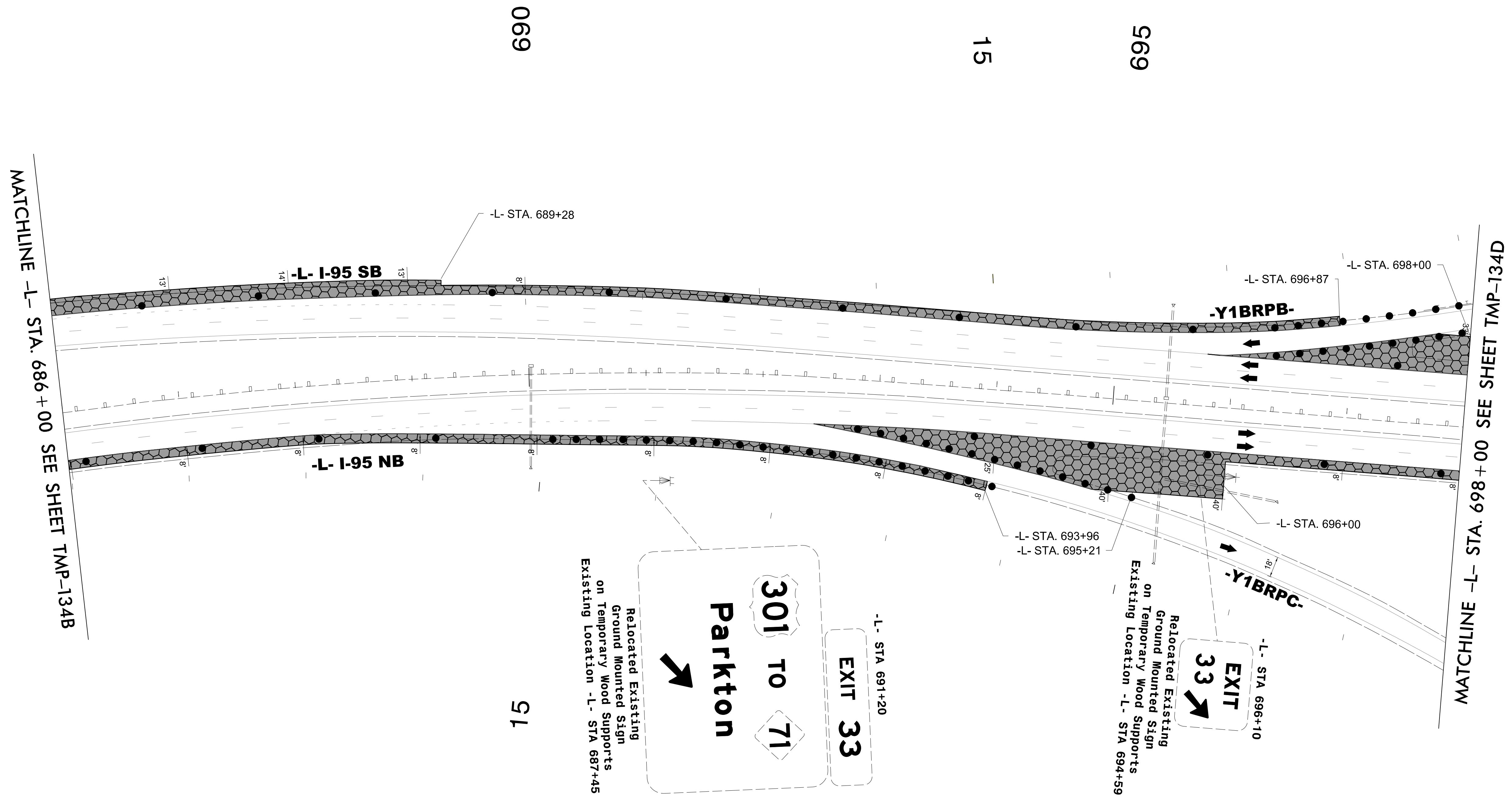
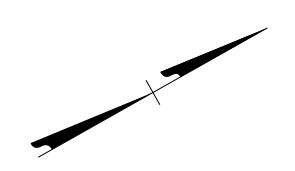

MATCHLINE -L- STA. 686+00 SEE SHEET TMP-134B

MATCHLINE -L- STA. 698+00 SEE SHEET TMP-134D

690

15

699

15

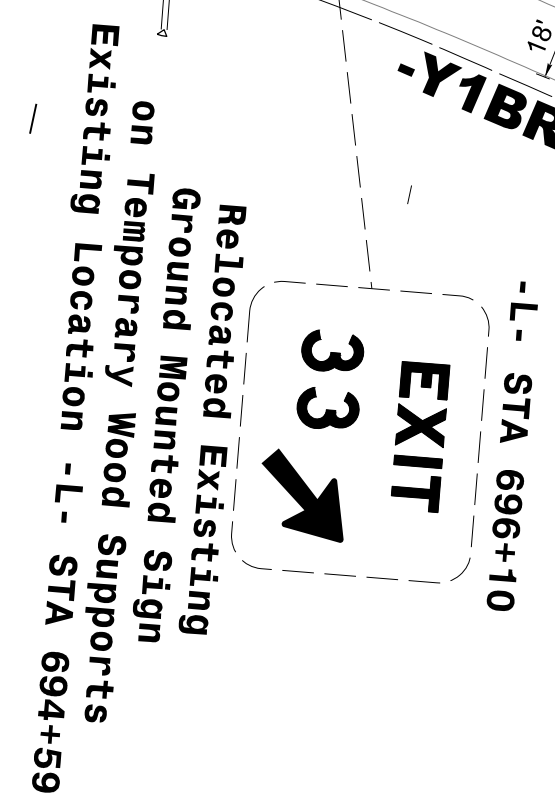
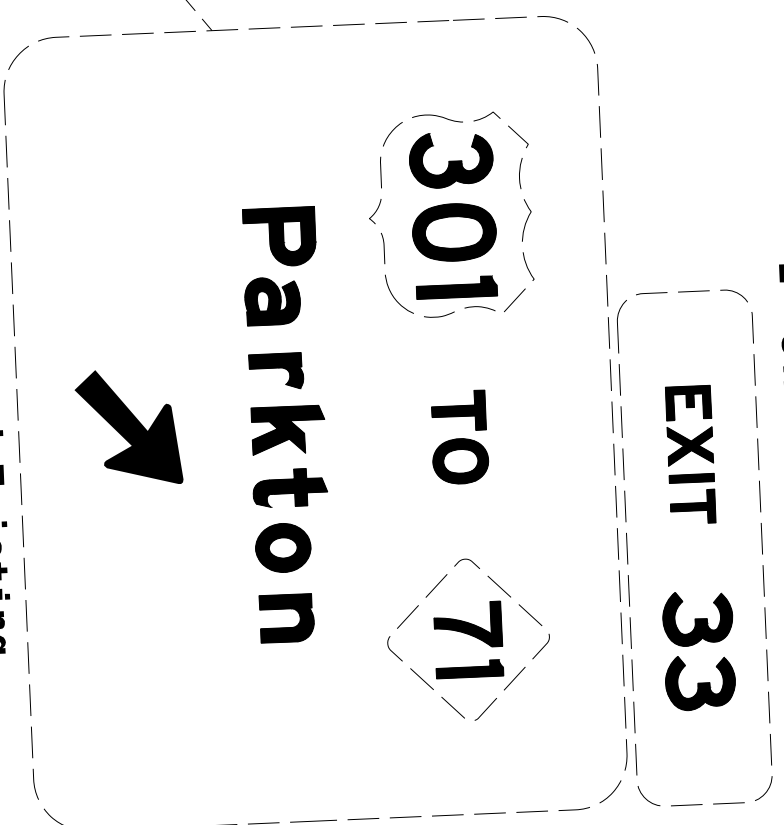

Relocated Existing Ground Mounted Sign on Temporary Wood Supports Existing Location -L- STA 687+45

Relocated Existing Ground Mounted Sign on Temporary Wood Supports Existing Location -L- STA 694+59

3/15/2022
U:\Traffic\Transportation Management Plan\TCP\PLAN SHEETS\I-5987B_TMP-134C_PHASE I_STEP 1A.dgn
angood

Stantec Consulting Services Inc.
801 Jones Franklin Road
Suite 300
Raleigh, NC 27606
Tel. 919.851.6866
Fax. 919.851.7024
www.stantec.com
License No. F-0672

DocuSigned by
J.W. Woollard
4/29/2022

**DOCUMENT NOT CONSIDERED FINAL
UNLESS ALL SIGNATURES COMPLETED**

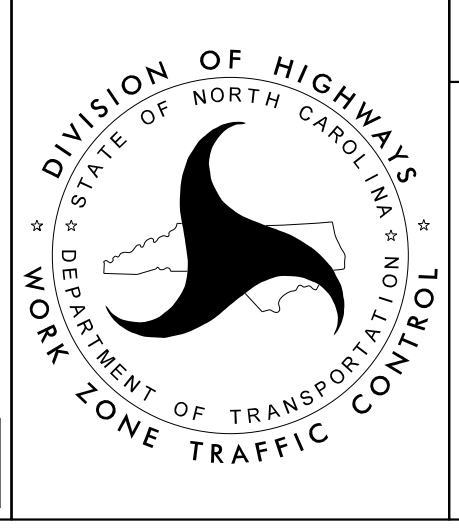

SECTION 2

-L- I-95
PHASE I
STEP 1A

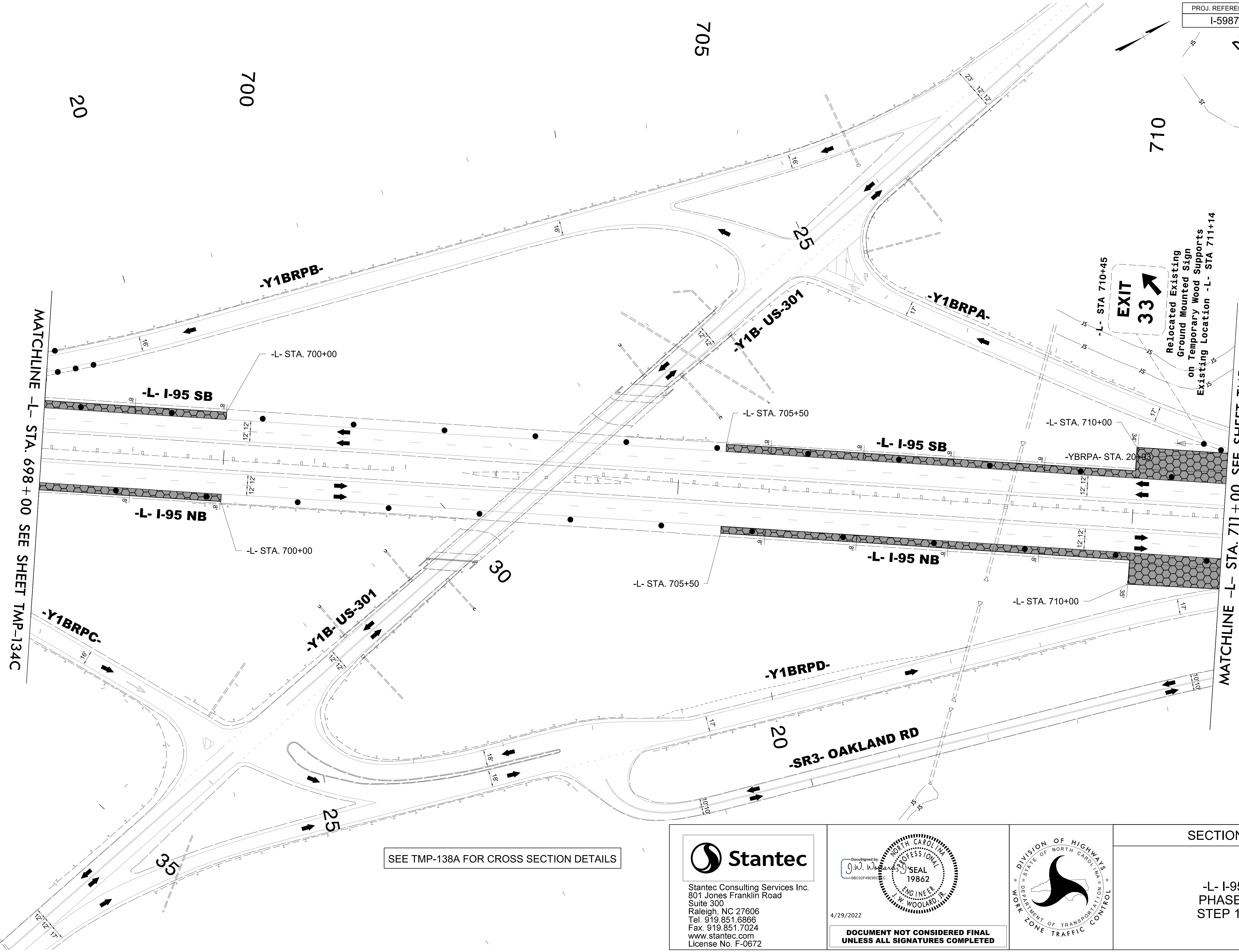

MATCHLINE -L- STA. 698 + 00 SEE SHEET TMP-134C

MATCHLINE -L- STA. 711 + 00 SEE SHEET TMP-134E

SEE TMP-138A FOR CROSS SECTION DETAILS

3/15/2022
 U:\Traffic\Transportation Management Plan\TCP\PLAN SHEETS\I-5987B_TMP-134D_PHASE I_STEP 1A.dgn
 angood

Stantec
 Stantec Consulting Services Inc.
 801 Jones Franklin Road
 Suite 300
 Raleigh, NC 27606
 Tel. 919.851.6866
 Fax. 919.851.7024
 www.stantec.com
 License No. F-0672

4/29/2022
**DOCUMENT NOT CONSIDERED FINAL
 UNLESS ALL SIGNATURES COMPLETED**

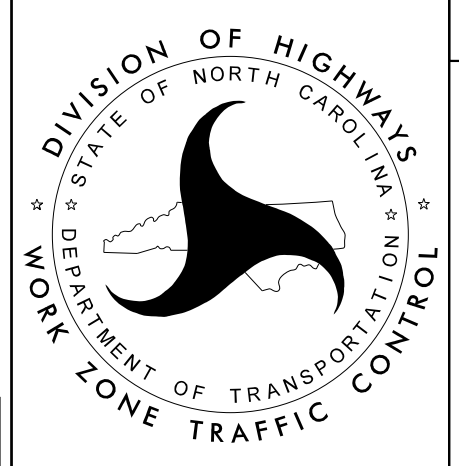
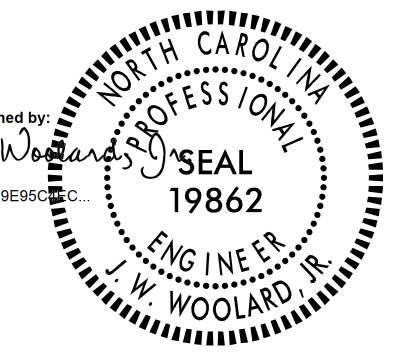

SECTION 2

-L- I-95
 PHASE I
 STEP 1A

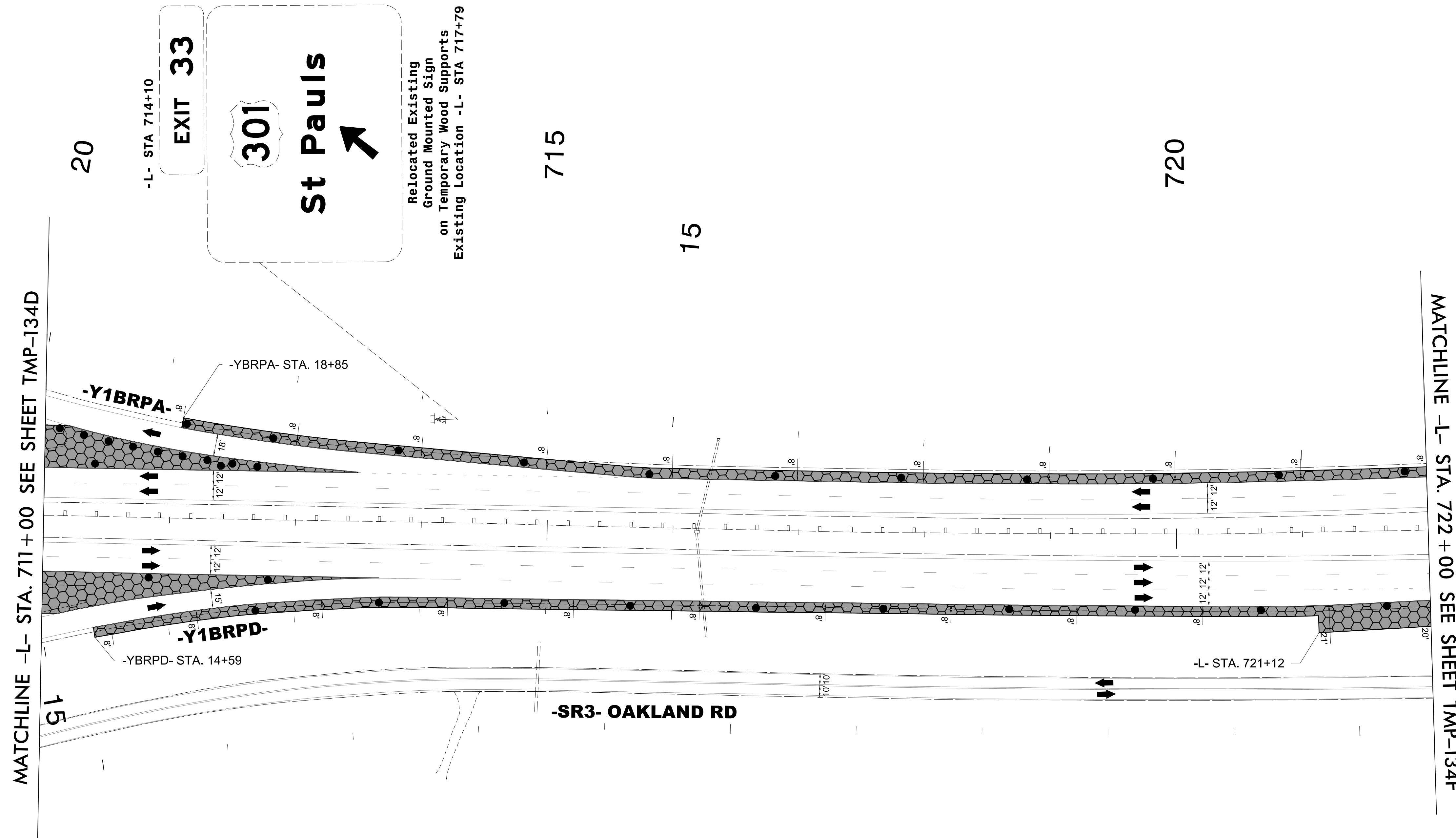
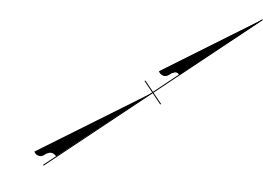

3/15/2022
U:\Traffic\Transportation Management\Plan\TCP\PLAN SHEETS\I-5987B_TMP-134E_PHASE I_STEP 1A.dgn
angood

Stantec Consulting Services Inc.
801 Jones Franklin Road
Suite 300
Raleigh, NC 27606
Tel. 919.851.6866
Fax. 919.851.7024
www.stantec.com
License No. F-0672

DocuSigned by
J.W. Woolard
4/29/2022

**DOCUMENT NOT CONSIDERED FINAL
UNLESS ALL SIGNATURES COMPLETED**

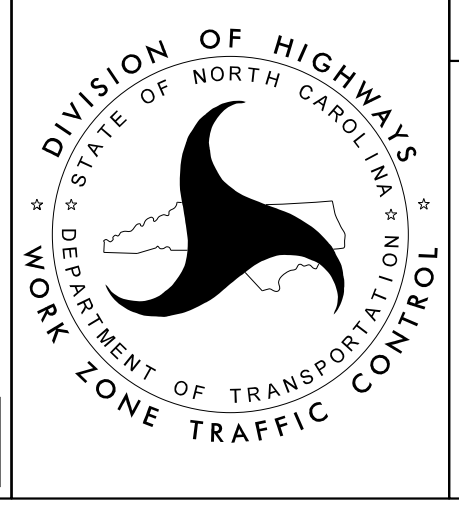

SECTION 2

-L- I-95
PHASE I
STEP 1A

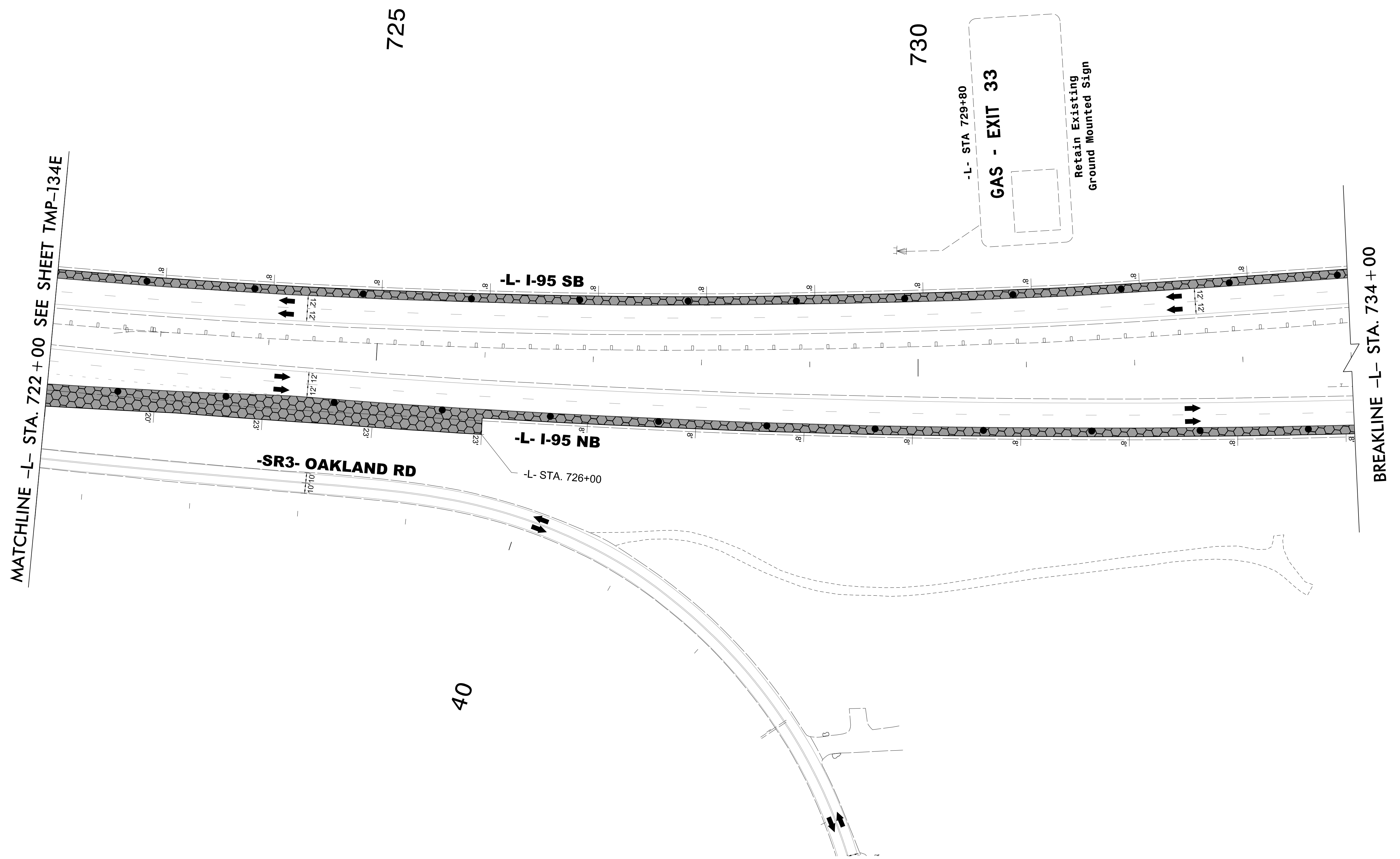
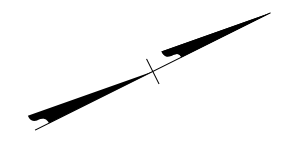

3/15/2022
U:\Traffic\Transportation Management\Plan\TCP\PLAN SHEETS\I-5987B_TMP-134F_PHASE I_STEP 1A.dgn
angood

Stantec Consulting Services Inc.
801 Jones Franklin Road
Suite 300
Raleigh, NC 27606
Tel. 919.851.6866
Fax. 919.851.7024
www.stantec.com
License No. F-0672

DocuSigned by
J.W. Woollard
4/29/2022

**DOCUMENT NOT CONSIDERED FINAL
UNLESS ALL SIGNATURES COMPLETED**

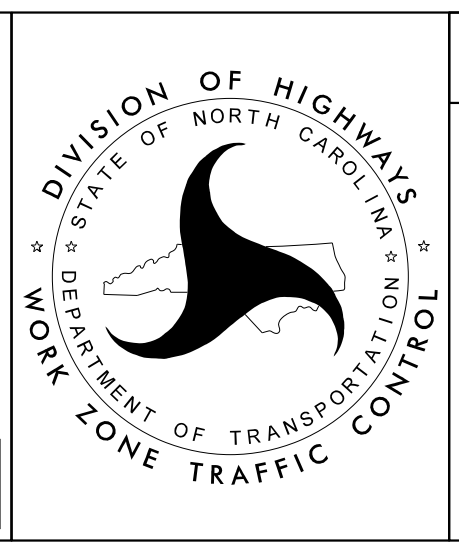

SECTION 2

-L- I-95
PHASE I
STEP 1A