

3/18/2022 11:06:46 AM G:\Projects\2020\Division 6 (Mott Mac - NV5)\I-5987B\Structures\Site 9 (L over Little Marsh Swamp)\Drawings\Final\I5987B_SMU_B1_770164.dgn

NOTES:
FOR NOTES, SEE SHEET 1 OF 6.

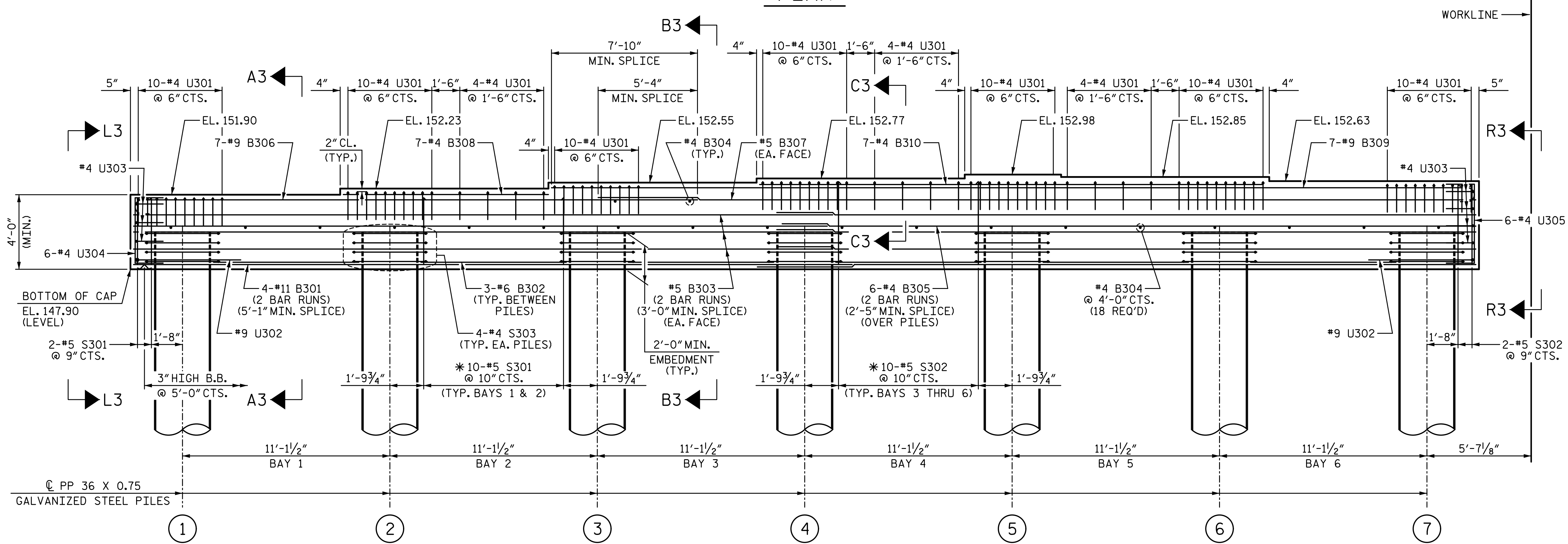
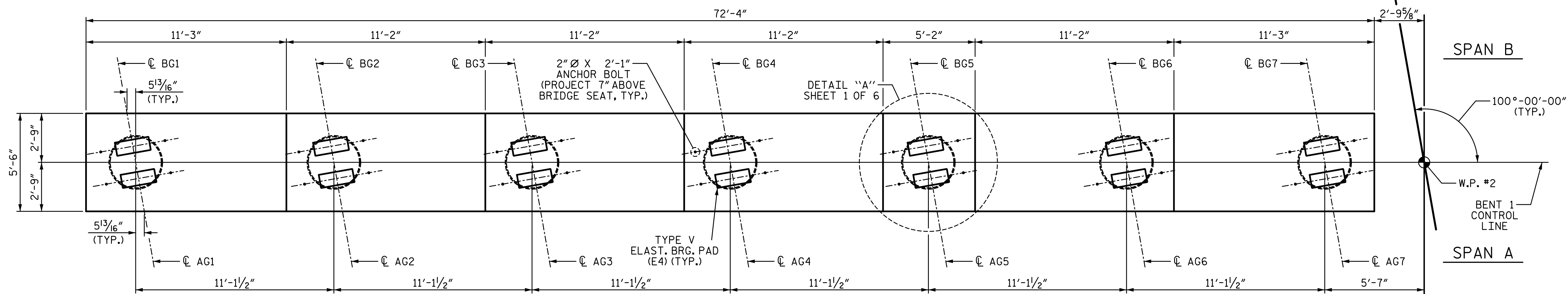

INDICATES PILE NUMBER

PROJECT NO. I-5987B
ROBESON COUNTY
STATION: 803+15.00 -L-

SHEET 5 OF 6

STATE OF NORTH CAROLINA
DEPARTMENT OF TRANSPORTATION
RALEIGH
SUBSTRUCTURE

BENT 1

STAGE III

REVISIONS						SHEET NO.
NO.	BY:	DATE:	NO.	BY:	DATE:	S9-55
1			3			TOTAL SHEETS 69
2			4			

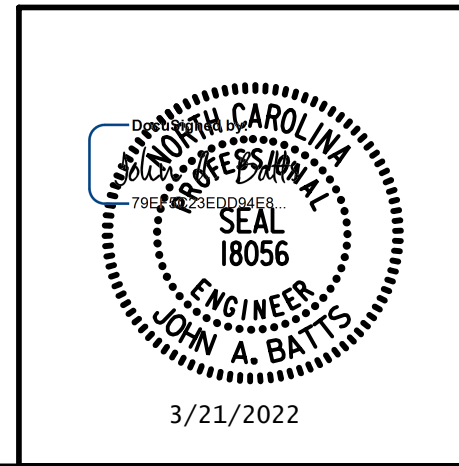

DRAWN BY: T. BANKOVICH DATE: 3-22
 CHECKED BY: J.A. BATTS DATE: 3-22
 DESIGN ENGINEER OF RECORD: J.A. BATTS DATE: 3-22

DOCUMENT NOT CONSIDERED FINAL UNLESS ALL SIGNATURES COMPLETED